

E. P. JONES.
 Railway Car Brake.

2 Sheets—Sheet 1.

No 100,900.

Patented March 15, 1870.

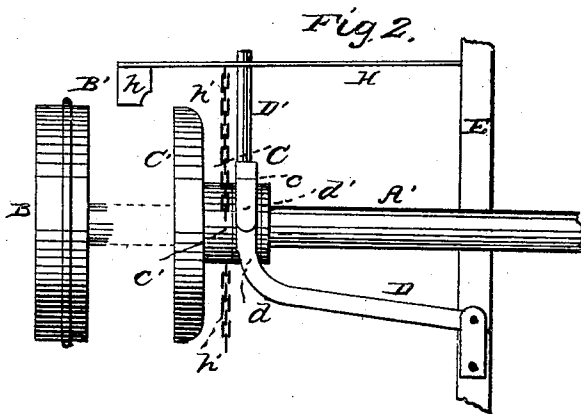
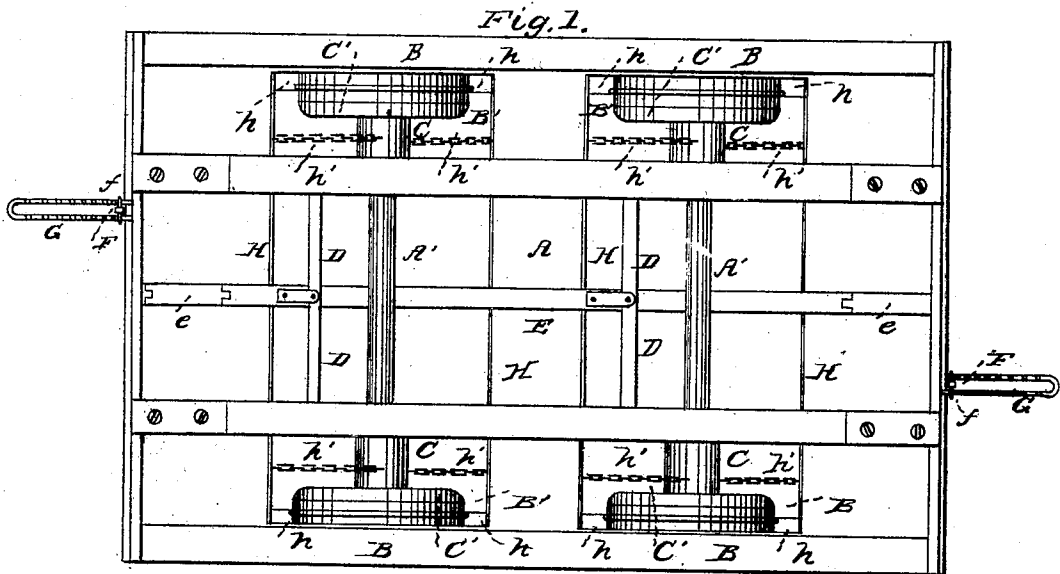

Witnesses:
 Edwin James.
 Alf. Holmead Jr.

Inventor:
 Edward P. Jones.
 per J. S. & Holmead.
 Attorney.

E. P. JONES.
Railway Car Brake.

No 100,900.

Patented March 15, 1870.

Fig. 3.

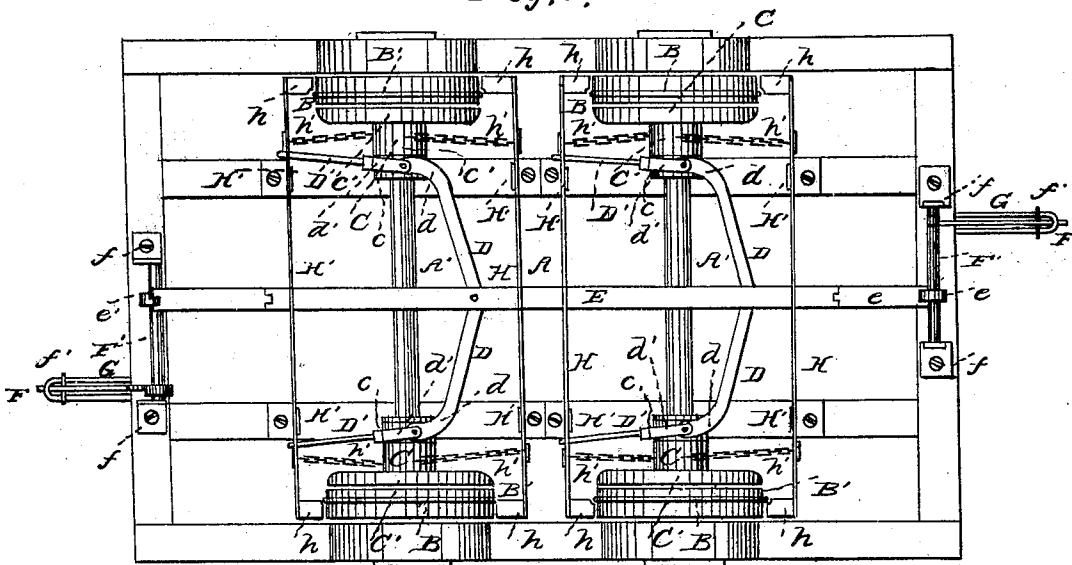
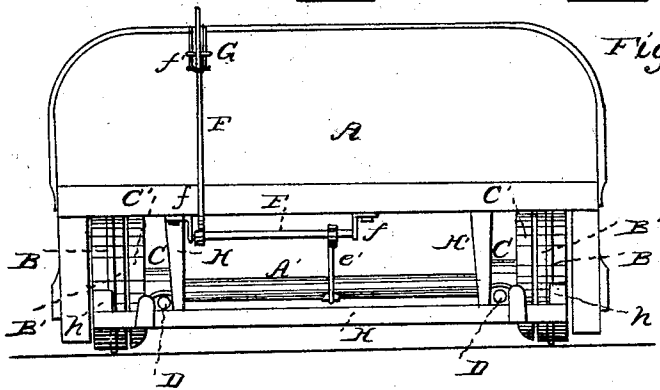

Fig. 4.



Witnesses:
Edwin James.
Alf. Holmead jr

Inventor:
Edward P Jones.
per J. E. M. Holmead
Attorney.

United States Patent Office.

EDWARD P. JONES, OF SHELL MOUND, MISSISSIPPI.

Letters Patent No. 100,900, dated March 15, 1870.

IMPROVED RAILWAY-CAR BRAKE.

The Schedule referred to in these Letters Patent and making part of the same.

To all whom it may concern:

Be it known that I, EDWARD P. JONES, of Shell Mound Post Office, in the county of Sunflower, and State of Mississippi, have invented certain new and useful Improvements in Car-Brakes; and I do hereby declare that the following is a full, clear, and exact description of the same, reference being had to the accompanying drawing and to the letters of reference marked thereon making part of this specification, in which—

Figure 1 is a top view of a car-truck, showing the different features of the brake in position.

Figure 2 is a detached view of the friction-clutch and its operating mechanism.

Figure 3 is a reverse view of fig. 1.

Figure 4 is an end view.

The nature of my invention consists in so connecting the brake-bars by short chains with friction-clutches; that, when the latter are revolved, the bars shall be so drawn as to bring its shoes in direct contact with the wheels of the cars.

The clutch consists of a sleeve or neck and a wheel or disk, the diameter of the former being such as to allow of its fitting loosely, so as to move freely on the axle, while the diameter of the disk is the same as that of the car-wheel.

Through toggles these clutches are connected with a horizontal arm or bar which runs the entire length of the car. This arm or bar is connected with and moved by a short lever or brake-handle.

To the sleeve of the clutch are attached short chains which are connected with brake-bars. These bars are secured in suitable bearings on the opposite sides of the axle.

The entire mechanism is so arranged that when the toggles are extended, the disks of the clutches are thrown against the wheels, when, through frictional contact, the same are caused to revolve, winding the chains and thus drawing on the brake-bars, so that their shoes are brought in contact with the wheels.

Thus it will be observed that although immense pressure can be exerted simply by working the brake-handle, at the same time through the disk and shoes, it is so equalized as to avoid undue or injurious strain at any one point.

To enable others skilled in the art to make and use my invention, I will now proceed to describe its construction and operation.

A is a car-truck.

A' A' are the axles; and

B B, the wheels, and may be all constructed and arranged in the usual manner, except the wheels, which are intended to have, at least it is deemed preferable that they should have, an annular rim or shoulder, B', cast or otherwise secured on their inner surface, to

prevent the wheel from being unduly worn by the clutch.

The friction-clutches are placed on the axle before the wheels are secured, and consist of a sleeve, C, and a disk-plate or wheel, C'.

The sleeve C is of such dimensions as to allow of its fitting loosely on the axle A', so that when the brake is "off," the revolution of the axle shall not impart motion to the same.

The disk-plate or wheel C' of the clutch is of the same diameter as that of the annular rim or shoulder B'. The inner surface of this sleeve C is slightly recessed, as at *c*, so as to leave a shoulder, *c'*. In this recessed face of the sleeve C works a ring or collar.

To this ring or collar are secured by a suitable bolt the clamping-jaws *d d* of the toggle-arms D D, and also the jaws *d' d'* of a guide-arm, D'.

The free end of this arm D' passes through and is supported in a suitable aperture or opening in the brake-bar H.

The toggle-arms D D are securely pivoted to the bar E. This bar E runs horizontally under the axles A' A', nearly the entire length of the car, and is connected by a link, *e*, to an arm, *e'*, which is permanently attached to the spindle F', to which the brake-handle or lever F is also fastened, and by which it is revolved. This spindle F', has its bearing in suitable plates *f f*.

The handle or lever F passes up vertically through a guide-plate, G, which is so recessed on its upper surface as to afford a ratchet bearing for the pin *f'* of the lever.

The plate G being so pivoted as to allow of its elevation or depression, the lever F can readily be secured and held at any desired point.

H H are brake-bars, and are secured in spring bearings H' H', at such points as to hold the shoes *h h* entirely free of the wheels.

K K are short chains that connect the brake-bars H H with the sleeve C, and by means of which, when the clutch is revolved, the shoes *h h* are drawn against the wheels.

Should the natural elasticity of the metal of the bearings H' H' prove not to be sufficient to unwind the clutch, in order that after the pressure is relieved the bar shall be so thrown back as to leave the slots free of the wheel; an additional spring can readily be applied.

I have thus given a detailed description of the different features used in connection with the brake. Many of these may be modified or varied without affecting the principle of my invention.

The operation is as follows:

The car is presumed to be in motion and the brake "off," as clearly shown in fig. 3. To throw the brake on, you have simply to force out the handle or lever

F to any desired point, where, through the pin *f'*, it can readily be secured in the ratchet-face of the plate G. This movement of the handle or lever F pushes toward the rear of the car the horizontal bar E, which extends the toggle-arms D D, thus forcing the clutch toward the wheel B.

So soon as the disk-plate or wheel C' of the clutch is brought to bear against the annular rim or flange B' of the wheel B, as clearly shown in fig. 1, through frictional contact, it is revolved, carrying with it the sleeve C, which winds the chains *k k*, and thus forces the shoes *h h* against the opposite sides of the wheel.

I thus produce a powerful brake, but one at the same time so arranged that the degree of its pressure can readily be regulated.

To free the brake, you have simply to disengage and return the lever-handle F, when the disk C', being no longer by pressure held against the wheel, is by the slightest momentum of the car freed from its contact, when the tension of the spring bearings H' H' will

readily unwind the chains, and allow the brake-bars H H to return to their former positions, carrying with them the shoes *h h*.

Having thus fully described my invention,

What I claim therein as new, and desire to secure by Letters Patent of the United States, is—

1. The friction-clutch C C', brake-bars H H, chains *k k*, and wheels B B, when the same are so combined and arranged as to operate substantially as described.

2. The friction-clutch C C', brake-bars H H, toggles D D, bar E, and lever F, when the same are so combined and arranged as to operate substantially as described.

In testimony whereof I have signed my name to this specification in the presence of two subscribing witnesses.

EDWD. P. JONES.

Witnesses:

B. B. LEWIS,
JNO. J. DUFF.