

April 11, 1950

G. M. GUSTIN

2,503,551

VENEER GLUING MACHINE

Filed June 14, 1946

3 Sheets-Sheet 1

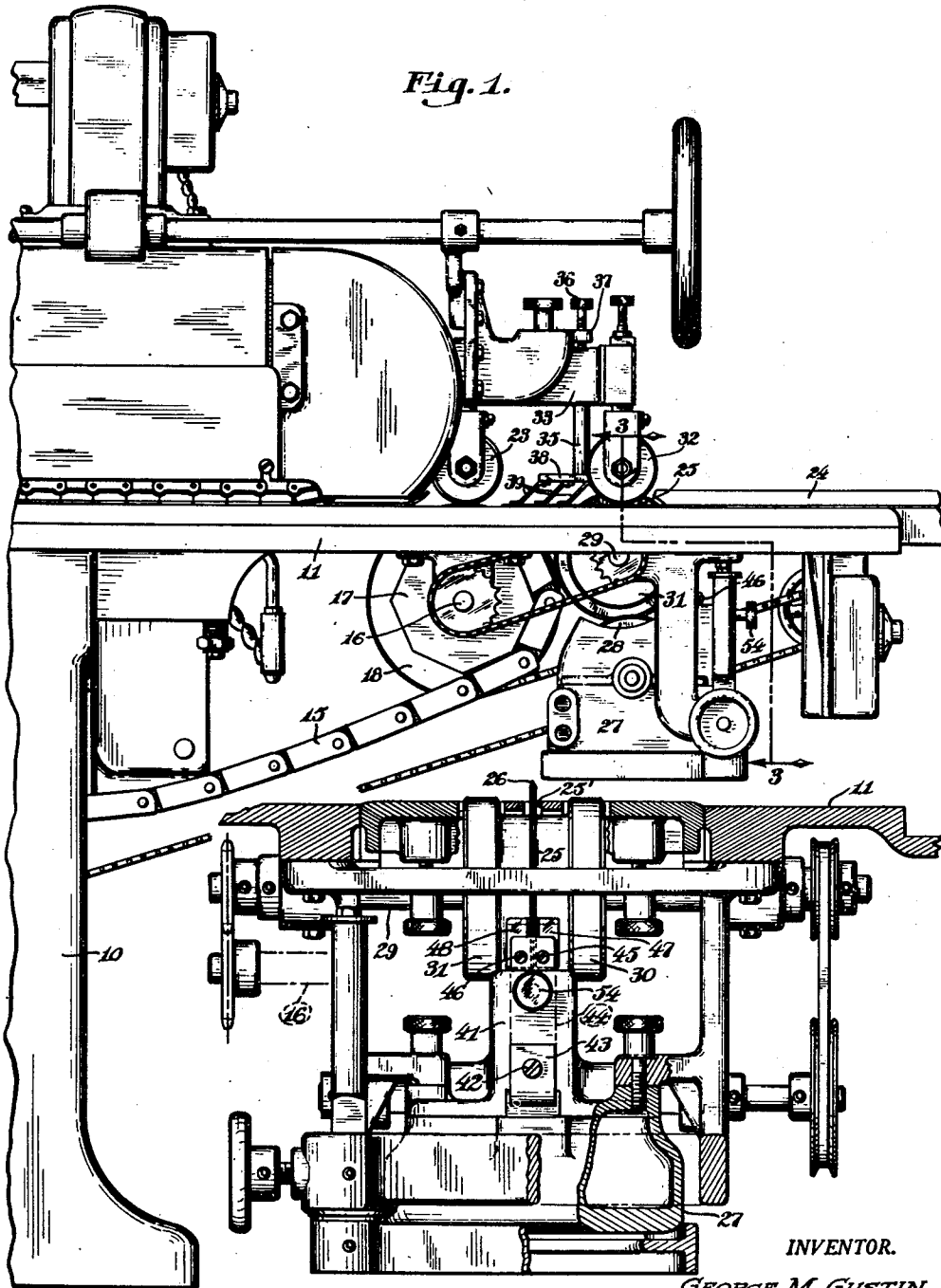

Fig. 3.

INVENTOR.
GEORGE M. GUSTIN,
BY: Harold B. Hood:
ATTORNEY.

April 11, 1950

G. M. GUSTIN

2,503,551

VENEER GLUING MACHINE

Filed June 14, 1946

3 Sheets-Sheet 2

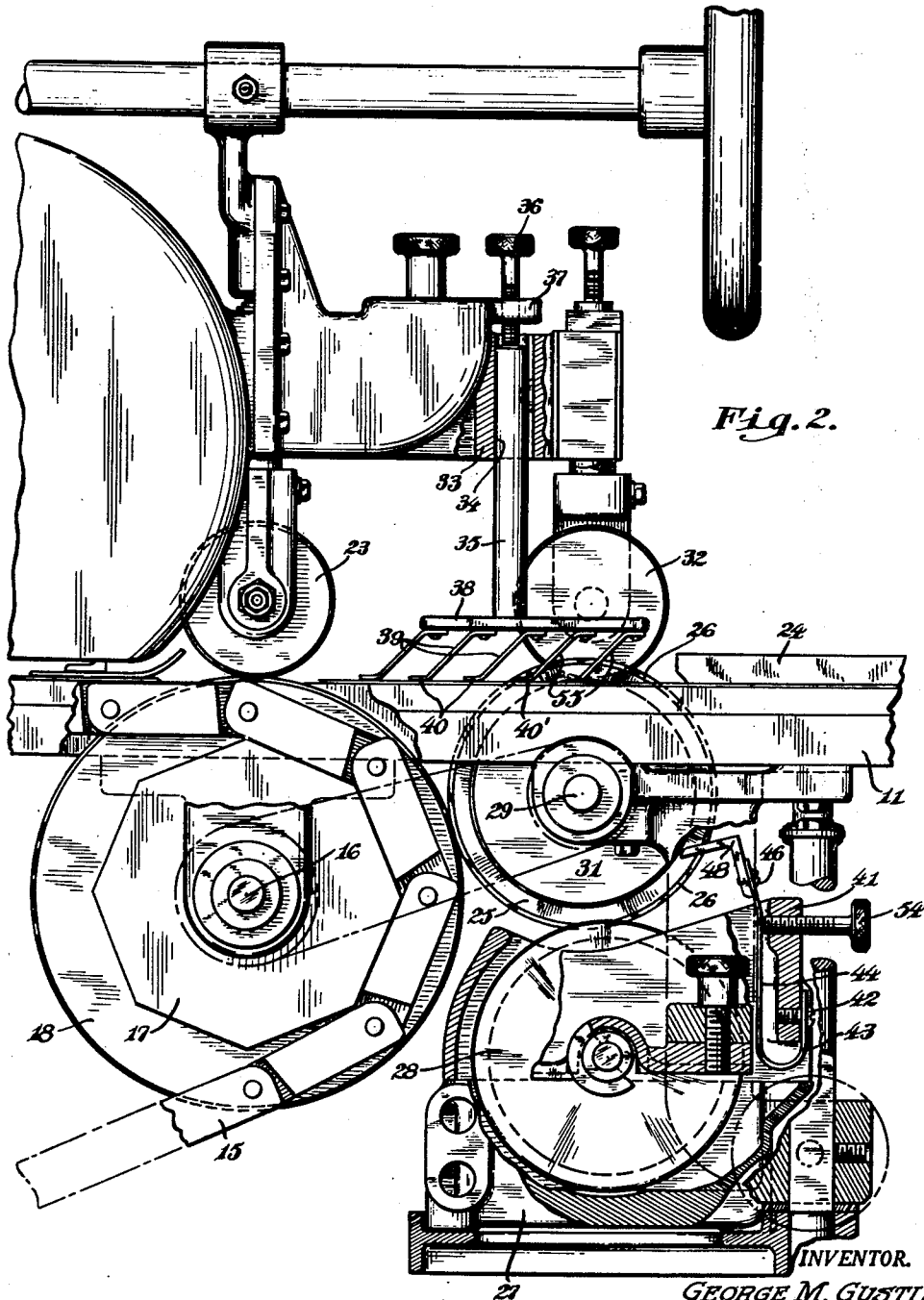

Fig. 2.

INVENTOR.

GEORGE M. GUSTIN,

BY:

Harold B. Hood.
ATTORNEY.

April 11, 1950

G. M. GUSTIN
VENEER GLUING MACHINE

2,503,551

Filed June 14, 1946

3 Sheets-Sheet 3

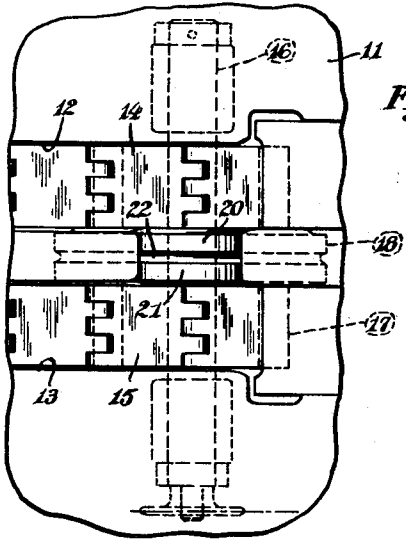

Fig. 4.

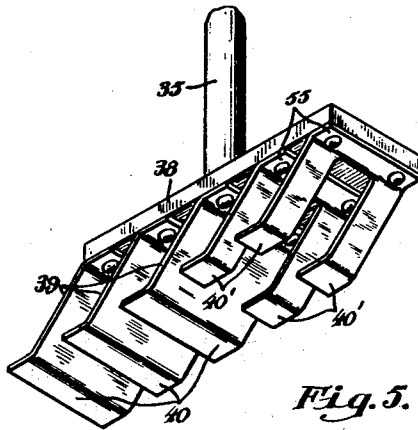

Fig. 5.

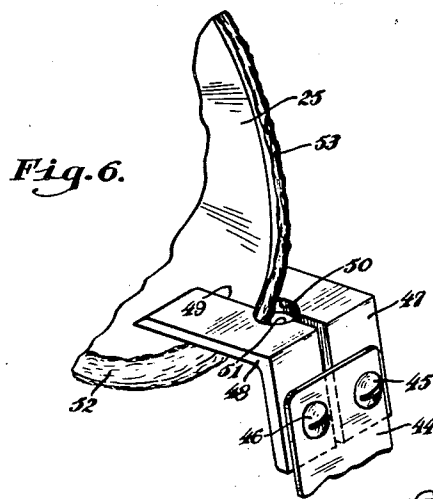

Fig. 6.

INVENTOR.
GEORGE M. GUSTIN,
BY: *Harold B. Hood*
ATTORNEY.

UNITED STATES PATENT OFFICE

2,503,551

VENEER GLUING MACHINE

George M. Gustin, Wabash, Ind., assignor to The
G. M. Diehl Machine Works, Inc., Wabash, Ind.,
a corporation of Indiana

Application June 14, 1946, Serial No. 676,845

15 Claims. (Cl. 144—279)

1

The present invention relates to a veneer gluing machine, and is particularly adapted for use in connection with a machine of the character disclosed in my prior Patent No. 2,372,894, the features of the present invention being, essentially, improvements and refinements upon the structure disclosed in the said prior patent.

While the invention is particularly concerned with machines in which glue is spread upon the mutually facing edge surfaces of veneer sheets to be edge-joined, and for subsequently bringing those faces into abutting engagement and hardening the glue, it will be apparent that at least some features of the invention are adaptable to machines of generally similar characteristics, but in which the first step in the operation is the moistening of the glue previously applied to the surfaces to be joined; or to machines of still different characteristics in which the advantages of the features disclosed and claimed herein find utility.

The primary objects of the present invention are to improve the application of glue or moisture to the surfaces to be joined, to minimize the tendency of such machines to leave deposits of glue on the upper faces of the pieces being joined, and to improve the feed of the pieces being handled to and through the machine. Further objects of the invention will appear as the description proceeds.

To the accomplishment of the above and related objects, my invention may be embodied in the form illustrated in the accompanying drawings, attention being called to the fact, however, that the drawings are illustrative only, and that change may be made in the specific construction illustrated and described, so long as the scope of the appended claims is not violated.

Fig. 1 is a fragmentary side elevation of portions of a machine constructed generally in accordance with the disclosure of my said prior Patent 2,372,894 but incorporating my present invention;

Fig. 2 is an enlarged similar elevation of certain of the parts shown in Fig. 1, some of the parts being shown in section for clarity of illustration;

Fig. 3 is a transverse section, taken substantially on the line 3—3 of Fig. 1 and looking in the direction of the arrows;

Fig. 4 is a fragmentary plan view, showing the conveyor units and feed roll;

Fig. 5 is a perspective view of a wiper element; and

Fig. 6 is a fragmentary, enlarged perspective, illustrating the manner in which the improved

2

scraper elements cooperate with the glue-applying disc.

The general construction and operation of the machine, in connection with which my present invention is described and illustrated, are well known in the art, and are specifically set forth in my said prior Patent 2,372,894. Briefly, it may be stated here that the machine comprises the base 10 mounting the support or bed 11 constructed and arranged to support two veneer sheets, or the like, in edge-facing relation, and to move said sheets together, in that relation, through the machine past a glue-applying or moistening station, with the facing edges of the two sheets slightly separated, and thereafter to bring the facing edges of the two sheets into abutting relation and to heat the joint between the sheets to cause the glue to set. The support 11 is formed with a pair of slots 12 and 13 (see Fig. 4) converging as they progress from the intake end to the discharge end of the machine, through which the serrated upper surfaces of the links of a pair of continuous conveyor units 14 and 15 are operatively presented to the two sheets of veneer to be moved through the machine. Suitable power means is connected to drive the two conveyor units and the other moving elements of the machine. The details of the structure thus far described form no part of the present invention.

A shaft 16, journaled on suitable bearings depending from the bed 11, supports a sprocket 17 over which runs one bight of the conveyor unit 15, and a corresponding sprocket (not shown) for the corresponding bight of the conveyor unit 14. Because of the convergence of the slots 12 and 13, and of the conveyor units 14 and 15, there is a constant tendency for the bights in the conveyor units running over the sprockets on the shaft 16 to move toward each other. I have taken advantage of that fact to provide an improvement in the feed means of the machine, by mounting loosely upon the shaft 16, between the two conveyor units, a feed roller 18, which preferably takes the form illustrated in Fig. 4, comprising the two lands 20 and 21, separated by a groove 22 which coincides with the spacing between the two sheets of veneer as they move through the machine. A presser roller 23 is suitably supported above the bed 11 in registry with the roller 18, so that the veneer sheets are engaged between the rollers 18 and 23.

The provision of the roller pair 18 and 23 improves the feeding operation of the machine, in that the rollers can take a grip on the veneer

sheets closer to the intake end of the machine than can the conveyor units 14 and 15 and their cooperating parts. On the other hand, it would not be feasible to drive the roller 18 with the shaft 16, because of the difference between the pitch diameter of the conveyor chains, as they move about their sprockets, and the pitch diameter of the roller. Because of the tendency of the conveyor chains to move toward each other, both units 14 and 15 frictionally engage the roller 18 to provide a friction drive thereof permitting, when necessary, slippage of the roller 18, with respect to the conveyor units, in either direction.

In accordance with standard practice, the bed 11 is provided with a fin 24, in advance of the glue-applying station, which properly determines the relative positions of the two sheets to be joined, as they approach that station. Whenever, in the present specification, the term "glue-applying station," or any similar term, is used, it is to be understood to apply to a station at which glue is applied to the sheets or at which glue previously applied is moistened. A glue applying disc 25 is mounted to project through a slot 25' in the bed 11 to a level above the top surface of veneer sheets supported upon the bed and moving past the disc. The peripheral portion of said disc is bevelled in both directions, as indicated at 26, to produce a relatively sharp edge. Suitably supported beneath the bed is a glue pot 27 into which dips a portion of the periphery of a glue delivery wheel 28, formed with a peripheral groove into which dips a portion of the periphery of the disc 25. Since the disc 25 and the wheel 28 are continuously driven, it will be seen that glue is continuously delivered by the wheel 28 from the pot 27 to the disc 25, and that the radial extent of the film of glue delivered to the disc 25 will be constant, dependent upon the degree of projection of the disc 25 into the groove of the wheel 28, regardless of the level of the glue in the pot 27. The disc 25 is mounted upon a shaft 29 which may be driven from the shaft 16; and the disc 25 is preferably flanked by rollers 30 and 31 with which cooperate presser rollers 32.

A bracket 33 is formed with a vertical bore 34 in which is reciprocally mounted a stem 35 of a wiper unit, a screw 36, threadedly mounted in a bracket projection 37, bearing upon the upper end of said stem to adjust the degree of pressure exerted by said unit. At its lower end, the stem 35 carries a foot 38 to the lower surface of which are secured a plurality of spring fingers or plates 39, inclining downwardly and toward the delivery end of the machine, and terminating in spatulae 40 pointing toward the delivery end of the machine. The fingers 39 are proportioned and designed to bridge the space between a pair of sheets moving through the machine.

It has been found that, as veneer sheets move past the disc 25, a relatively small amount of glue is deposited on their facing edges by that portion of the disc which rises as it passes the sheets; while a larger proportion of glue is deposited on the sheets by that portion of the disc which is moving downwardly as it passes the sheets. An excess of glue is usually provided, and it has been found that some of that glue will be wiped off the descending portion of the disc by the upper corners of the veneer sheet edges, and will be deposited upon the upper surfaces of the sheets closely adjacent to those

edges. The spatulae 40, therefore, serve a double function, holding the veneer sheet edges against buckling and wrinkling, and at the same time wiping the glue deposited upon the upper surfaces of the sheets and tending to force that glue back into the space between the facing edges of the sheets.

Preferably, the foot 38 carries two spring units 55, near its intake end, constructed otherwise to conform to the fingers 39, and terminating in similar spatulae 40', but split or bifurcated to straddle the disc 25, in the manner most clearly illustrated in Figs. 2 and 5.

Engagement of the veneer sheets with the disc 25 as portions of the disc rise past said sheets tends to spread the glue radially inwardly on said disc, as will be clear from a consideration of Fig. 2. Continuous operation over relatively long periods will spread and increasingly thicken the film of glue over the radially inward portions of said disc. In the past, it has been customary to provide so-called "scraper fingers" cooperative with the disc at a point between the glue supply station and the glue delivery station; but the function of those fingers, in the past, has been to limit the thickness of the glue film carried by the disc to the delivery station, and consequently those fingers have invariably been set to clear the disc surfaces by a carefully calculated decimal of an inch.

Because of the difficulty of attaining and maintaining absolute finger setting, and more particularly because of the fact that, after some use, the disc 25 will frequently run out of true, those scraper arrangements have been far from satisfactory in their results. Uniformity of glue film thickness has been found to be commercially unattainable upon the theory of such devices.

I have therefore proceeded to an entirely new theory for maintaining uniform glue delivery. Upon a bracket 41 which may be carried by the glue pot, I secure, by means of a screw 42, whose axis is substantially normal to the vertical plane including the axis of the disc 25, one end 43 of a resilient spring leaf 44. In a preferred embodiment, which renders said screw readily accessible, the leaf end 43 is rebent, as shown. The free end of the leaf 44 carries, by means of a pair of screws 45 and 46, whose axes are likewise substantially normal to the above mentioned plane, a pair of L-shaped scraper fingers 47 and 48. Said fingers are adjustable about the axes of their supporting screws, whereby their facing surfaces (see 49 of Fig. 6) are movable toward and away from each other. Those surfaces are so designed as to engage, respectively, the opposite faces of the disc 25 in a region radially inwardly removed from the bevelled surfaces 26 of said disc; and the fingers are formed with registering notches 50 and 51 in their facing surfaces, whereby they abruptly clear the bevelled portions of the disc. The parts are so proportioned and designed that the fingers engage the disc in a line located below the horizontal plane including the axis of the wheel, and inclined downwardly and toward the vertical plane including the axis of the wheel. Otherwise stated, the fingers engage opposite disc surfaces on lines inclining radially outwardly in the direction of disc rotation. Therefore, as the wheel or disc 25 rotates in a counter-clockwise direction, as illustrated, the engagement of the scraper fingers with the disc surfaces tends to guide and force glue adhering to said surfaces radially outwardly onto the bevelled surfaces 26, where the glue

5

will gather in a bead. In Fig. 6, I have shown, at 52, a film of glue, below the scraper station, adhering to portions of the disc extending radially inwardly from the bevelled surfaces; and I have shown at 53 the bead formation of glue which is produced as the disc moves past the surfaces 49 and notches 50 and 51 of the fingers 47 and 48.

The leaf 44 is so designed that its inherent resiliency tends to move the fingers away from the vertical plane including the axis of the disc; and a screw 54 is mounted in a threaded aperture in the bracket 41 to engage the leaf 44 near its free end; so that, by adjustment of said screw, the position of the scraper fingers relative to said vertical plane may be manually adjusted. Obviously, manipulation of the screw 54 will vary the size of the bead 53 of glue which forms on the periphery of the disc 25, the bead size being increased by adjustment of the fingers toward the vertical plane including the disc axis, or decreased by adjustment thereof away from said plane. As obviously, other means, such as a rectilinear guide and a slide mounted thereon, could be provided for carrying the scraper fingers; but I consider the illustrated means to be most advantageous because of the elimination of relatively movable parts and the added resiliency, transversely of the disc, inherent in the structure herein disclosed.

Since the scraper fingers are intended to engage the opposite surfaces of the disc, the adjustment thereof toward and away from each other is a very simple matter. The screws 45 and 46 may be loosened and, with the fingers straddling the disc, the fingers may merely be pressed together as tightly as may be possible by hand, whereafter the screws 45 and 46 are tightened to hold the fingers in adjusted position. Problems which have arisen with previous structures as a result of wobbling of the disc are automatically overcome by the present structure, since there is sufficient lateral resiliency in the spring structure, particularly because of the U-shaped base thereof, to permit the fingers to follow any such disc wobble. Adjustment of the radial depth of engagement of the fingers upon the disc is accomplished by the simple manipulation of the screw 54.

The various features herein described cooperate to improve the operation of the machine as a whole by more effectively controlling the accurate application of glue to the facing edges of the sheets to be joined, more effectively controlling those sheets edges against buckling and wrinkling, and overcoming the tendency of previously-known devices to leave glue on the upper surfaces of the sheets edges and by more accurately and effectively accomplishing travel of the sheets through the machine.

I claim as my invention:

1. In a machine for applying liquid to the adjacent edges of sheets to be edge-joined, a rotating disc, means for moving such sheets past said disc with each sheet substantially in contact with one face of the peripheral portion of said disc, means for continuously applying liquid to the peripheral portion of said disc at a point peripherally spaced from the point of operative association of said sheets with said disc, and scraper means located peripherally between said point of application of liquid to said disc and said point of operative association of said sheets with said disc, said scraper means engaging both faces of said disc only in a region spaced radially inwardly from the disc periphery and inclining

6

radially outwardly and in the direction of rotation of said disc to force liquid adhering to said disc faces to move radially outwardly toward the peripheral edge of said disc as said disc rotates.

2. In a machine for applying liquid adhesive to the adjacent edges of sheets to be edge-joined, a rotating disc, means for continuously applying liquid adhesive to the opposite faces of said disc in the peripheral region thereof, means for moving a pair of sheets to be joined simultaneously past said disc in substantial contact with said opposite disc faces, the periphery of said disc projecting past both boundaries of said sheet edges, and pressure means engaging said sheets, after said sheets have passed said disc, and spanning the adjacent edges of said sheets to urge liquid adhesive, deposited on said sheets beyond said boundaries, into the space between said edges.

3. In a machine for applying liquid to the adjacent edges of a pair of sheets to be edge-joined, a platform, conveyor means for each of said sheets extending longitudinally of said platform for cooperative engagement with sheets supported on said platform, said conveyor means converging from the intake end of said machine toward the delivery end thereof, a shaft supporting elements of both said conveyor means at the intake end of the machine, and a feed roller loosely supported on said shaft between said respective elements and disposed for cooperation with both of a pair of sheets fed to said machine, said conveyor elements frictionally engaging the opposite ends of said roller, respectively.

4. In a machine for applying liquid to the adjacent edges of sheets to be edge-joined, a rotating disc, means for moving such sheets past said disc with each sheet substantially in contact with one face of the peripheral portion of said disc, means for continuously applying liquid to the peripheral portion of said disc at a point peripherally spaced from the point of operative association of said sheets with said disc, and scraper means located peripherally between said point of application of liquid to said disc and said point of operative association of said sheets with said disc, said scraper means continuously engaging both faces of said disc only in a region spaced radially inwardly from the disc periphery and upon a chordal line inclining in the direction of disc rotation from the innermost point of engagement toward said disc periphery.

5. In a machine for applying liquid to the adjacent edges of sheets to be edge-joined, a rotating disc, means for moving such sheets past said disc with each sheet substantially in contact with one face of the peripheral portion of said disc, means for continuously applying liquid to the peripheral portion of said disc at a point peripherally spaced from the point of operative association of said sheets with said disc, and scraper means located peripherally between said point of application of liquid to said disc and said point of operative association of said sheets with said disc, said scraper means including portions continuously engaging both faces of said disc in a region spaced radially inwardly from the disc periphery and upon a chordal line inclining in the direction of disc rotation from the innermost point of engagement toward said disc periphery, and including other portions laterally spaced from said disc at the periphery thereof, whereby liquid adhering to the faces of said disc is moved radially outwardly thereon, as said disc rotates, to gather as a bead at the disc periphery.

7

6. In a machine for applying liquid to the adjacent edges of sheets to be edge-joined, a wheel mounted for rotation on a horizontal axis, means for moving sheets past said wheel with each sheet substantially in contact with one face of the peripheral portion of said wheel, means for continuously applying liquid to the peripheral portion of said wheel at a point peripherally spaced from the point of operative association of such sheets with said wheel, and scraper means located peripherally between the liquid-applying means and said point of operative association of such sheets with said wheel comprising a leaf supported at one end and resiliently movable at its other end toward and away from the vertical plane including the axis of said wheel, and two scraper fingers supported on the last-mentioned end of said leaf and engaging the opposite faces of said wheel, respectively, in a region spaced radially inwardly from the periphery of said wheel, said fingers being adjustable toward and away from the median plane therebetween.

7. In a machine for applying liquid to the adjacent edges of sheets to be edge-joined, a wheel mounted for rotation on a horizontal axis, means for moving sheets past said wheel with each sheet substantially in contact with one face of the peripheral portion of said wheel, means for continuously applying liquid to the peripheral portion of said wheel at a point peripherally spaced from the point of operative association of such sheets with said wheel, and scraper means located peripherally between said liquid-applying means and said point of operative association of such sheets with said wheel comprising a leaf supported at one end and resiliently movable at its other end toward and away from the vertical plane including the axis of said wheel, and two scraper fingers supported on the last-mentioned end of said leaf and engaging the opposite faces of said wheel, respectively, in a region located below the horizontal plane including said wheel axis and being inclined downwardly and toward said vertical plane.

8. In a machine for applying liquid to the adjacent edges of sheets to be edge-joined, a wheel mounted for rotation on a horizontal axis, means for moving sheets past said wheel with each sheet substantially in contact with one face of the peripheral portion of said wheel, means for continuously applying liquid to the peripheral portion of said wheel at a point peripherally spaced from the point of operative association of such sheets with said wheel, and scraper means located peripherally between said liquid-applying means and said point of operative association of such sheets with said wheel comprising a leaf supported at one end and resiliently movable at its other end toward and away from the vertical plane including the axis of said wheel, and two scraper fingers supported on the last-mentioned end of said leaf and engaging the opposite faces of said wheel, respectively, in a region spaced radially inwardly from the periphery of said wheel, located below the horizontal plane including said wheel axis and being inclined downwardly and toward said vertical plane.

9. In a machine for applying liquid to the adjacent edges of sheets to be edge-joined, a wheel mounted for rotation on a horizontal axis, means for moving sheets past said wheel with each sheet substantially in contact with one face of the peripheral portion of said wheel, means for continuously applying liquid to the peripheral portion of said wheel at a point peripherally

8

spaced from the point of operative association of such sheets with said wheel, and scraper means located peripherally between said liquid-applying means and said point of operative association of such sheets with said wheel comprising a leaf supported at one end and resiliently movable at its other end toward and away from the vertical plane including the axis of said wheel, two scraper fingers supported on the last-mentioned end of said leaf and engaging the opposite faces of said wheel, respectively, in a region spaced radially inwardly from the periphery of said wheel, and screw means engaging said leaf and operative to shift the same, against the bias of said leaf, in a line normal to said vertical plane.

10. In a machine for applying liquid to the adjacent edges of sheets to be edge-joined, a wheel mounted for rotation on a horizontal axis, means for moving sheets past said wheel with each sheet substantially in contact with one face of the peripheral portion of said wheel, means for continuously applying liquid to the peripheral portion of said wheel at a point peripherally spaced from the point of operative association of such sheets with said wheel, and scraper means located peripherally between said liquid-applying means and said point of operative association of such sheets with said wheel comprising a leaf supported at one end for adjustment about an axis normal to the vertical plane including the axis of said wheel and resiliently movable at its other end toward and away from said plane, a pair of scraper fingers adjustably mounted on said last-mentioned leaf end for adjustment toward and away from each other about parallel axes substantially normal to said vertical plane, said fingers engaging the opposite faces of said wheel, respectively, in a region spaced radially inwardly from the periphery of said wheel, and adjustable means operatively associated with said leaf and operable to control the position of said fingers relative to said vertical plane.

11. In a machine for applying liquid to the adjacent edges of sheets to be edge-joined, a support for a pair of such sheets, sheet-conveying means extending longitudinally of the support and operable to convey a pair of sheets simultaneously along said support in edge-facing separated relation while continuously urging said sheets toward each other, a disc mounted for rotation upon a transverse axis beneath said support and projecting beyond said support a distance greater than the thickness of such sheets and into substantial contact with the facing edges of such sheets, means for applying liquid to the peripheral portion of said disc to be transferred thereby to said sheets, and means located immediately beyond said disc and flatly frictionally engaging the upper surfaces of said sheets to urge liquid deposited on said upper surfaces into the space between said sheets.

12. In a machine for applying liquid to the adjacent edges of sheets to be edge-joined, a support for a pair of such sheets, sheet-conveying means extending longitudinally of said support and operable to convey a pair of sheets simultaneously along said support in edge-facing separated relation while continuously urging said sheets toward each other, a disc mounted for rotation upon a transverse axis beneath said support and projecting beyond said support a distance greater than the thickness of such sheets and into substantial contact with the facing edges of such sheets, means for applying liquid to the peripheral portion of said disc to be trans-

ferred thereby to said sheets, and means located immediately beyond said disc and flatly frictionally engaging the upper surfaces of said sheets and bridging the space between said sheets at a point before said sheet edges are moved into mutual engagement to urge liquid deposited on said upper surfaces into the space between said sheets.

13. In a machine for applying liquid to the adjacent edges of sheets to be edge-joined, a support for a pair of such sheets, sheet-conveying means extending longitudinally of said support and operable to convey a pair of sheets simultaneously along said support in edge-facing separated relation while continuously urging said sheets toward each other, a disc mounted for rotation upon a transverse axis beneath said support and projecting beyond said support a distance greater than the thickness of such sheets and into substantial contact with the facing edges of such sheets, means for applying liquid to the peripheral portion of said disc to be transferred thereby to said sheets, a plurality of spring leaves mounted above said support, inclining downwardly and toward the delivery end of the machine and terminating in spatulae pointing toward said delivery end, said spatulae being positioned to bear resiliently upon the upper surfaces of sheets moving through the machine, in bridging relation to the space between the facing edges of such sheets, and further spring leaves located on opposite sides of said disc, inclining downwardly and toward the delivery end of the machine and terminating in spatulae pointing toward said delivery end, each of said last-named spatulae bearing resiliently upon the upper face of one sheet only adjacent the edge of said sheet facing said disc.

14. In a machine for adhesively edge-joining sheets, a support for such sheets, a pair of continuous conveyor units positioned for operative engagement with sheets on said support, a feed

roller positioned for operative engagement with sheets on said support, two axially-spaced sprockets, each supporting one end bight of one of said conveyor units, common journal means for said sprockets and said feed roller, said feed roller being located between said sprockets and being rotatable independently of said sprockets, and axially-spaced sprocket means supporting the opposite end bight of each of said conveyor units, the axial spacing between said last-named sprocket means being less than the axial length of said feed roller, whereby said first-named sprockets are continuously urged toward each other and into endwise frictional engagement with said feed roller.

15. In combination with a rotating disc and means for continuously supplying a viscous liquid to the peripheral region of said disc, a scraper device comprising a pair of fingers providing, adjacent their free ends, parallel scraping surfaces spaced apart a distance substantially equal to the thickness of said disc and respectively engaging opposite surfaces of said disc, and means supporting said fingers with said surfaces inclined radially outwardly in the direction of disc rotation, the mutually-facing edges of said fingers retreating from the planes of said disc surfaces directly adjacent the periphery of said disc.

GEORGE M. GUSTIN.

REFERENCES CITED

The following references are of record in the file of this patent:

UNITED STATES PATENTS

| Number | Name | Date |
|-----------|---------|---------------|
| 497,299 | Brigham | May 16, 1893 |
| 1,339,107 | Dittmar | May 4, 1920 |
| 1,510,465 | Dittmar | Oct. 7, 1924 |
| 1,575,551 | Dove | Mar. 2, 1920 |
| 2,305,525 | Gustin | Dec. 15, 1942 |
| 2,372,894 | Gustin | Apr. 3, 1945 |