



- (51) International Patent Classification:
F25D 23/02 (2006.01) F25D 23/06 (2006.01)
F25D 29/00 (2006.01)
- (21) International Application Number:
PCT/KR2016/006949
- (22) International Filing Date:
29 June 2016 (29.06.2016)
- (25) Filing Language: English
- (26) Publication Language: English
- (30) Priority Data:
10-2015-0097318 8 July 2015 (08.07.2015) KR
- (71) Applicant: SAMSUNG ELECTRONICS CO., LTD.
[KR/KR]; 129, Samsung-ro, Yeongtong-gu, Suwon-si,
Gyeonggi-do 16677 (KR).
- (72) Inventors: KIM, Hyun Joo; 261, Yeongtong-ro, Yeong-
tong-gu, Suwon-si, Gyeonggi-do 16679 (KR). SEO, Yong
Man; 128, Sinwon-ro, Yeongtong-gu, Suwon-si, Gyeong-
gi-do 16679 (KR). HWANG, In Sung; 55, Gwong-

wang-ro, Gwonseon-gu, Suwon-si, Gyeonggi-do 16582 (KR). JANG, Bok Hyun; 1-8, Hyowon-ro 148beon-gil, Paldal-gu, Suwon-si, Gyeonggi-do 16574 (KR). LEE, Tae Youl; 259, Yeongtong-ro, Yeongtong-gu, Suwon-si, Gyeonggi-do 16679 (KR). CHOI, Jeong Won; 19, Gyeongsu-daero 277beon-gil, Gwonseon-gu, Suwon-si, Gyeonggi-do 16590 (KR).

(74) Agent: SELIM INTELLECTUAL PROPERTY LAW FIRM; 10F and 11F, Taewoo Bldg., 285, Gangnam-daero, Seocho-gu, Seoul 06729 (KR).

(81) Designated States (unless otherwise indicated, for every kind of national protection available): AE, AG, AL, AM, AO, AT, AU, AZ, BA, BB, BG, BH, BN, BR, BW, BY, BZ, CA, CH, CL, CN, CO, CR, CU, CZ, DE, DK, DM, DO, DZ, EC, EE, EG, ES, FI, GB, GD, GE, GH, GM, GT, HN, HR, HU, ID, IL, IN, IR, IS, JP, KE, KG, KN, KP, KZ, LA, LC, LK, LR, LS, LU, LY, MA, MD, ME, MG, MK, MN, MW, MX, MY, MZ, NA, NG, NI, NO, NZ, OM, PA, PE, PG, PH, PL, PT, QA, RO, RS, RU, RW, SA, SC, SD, SE, SG, SK, SL, SM, ST, SV, SY, TH, TJ, TM, TN, TR, TT, TZ, UA, UG, US, UZ, VC, VN, ZA, ZM, ZW.

[Continued on next page]

(54) Title: REFRIGERATOR

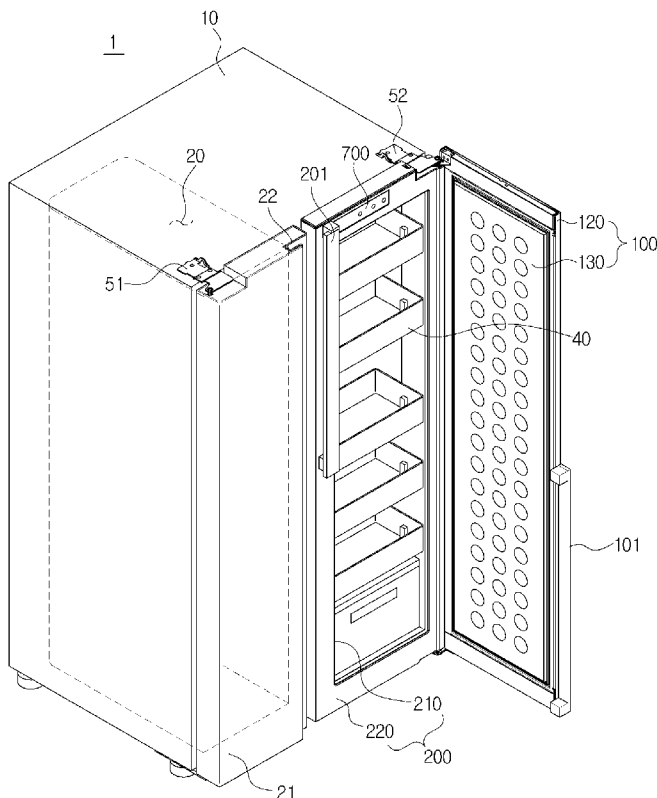

(57) Abstract: A refrigerator may include a storage compartment, an inner door which comprises an opening having a size corresponding to a size of the storage compartment, a plurality of door guards, and an outer door which open and close the storage compartment, wherein the inner door comprises a control unit may control an internal environment of the storage compartment.

WO 2017/007164 A1



(84) Designated States (*unless otherwise indicated, for every kind of regional protection available*): ARIPO (BW, GH, GM, KE, LR, LS, MW, MZ, NA, RW, SD, SL, ST, SZ, TZ, UG, ZM, ZW), Eurasian (AM, AZ, BY, KG, KZ, RU, TJ, TM), European (AL, AT, BE, BG, CH, CY, CZ, DE, DK, EE, ES, FI, FR, GB, GR, HR, HU, IE, IS, IT, LT, LU, LV, MC, MK, MT, NL, NO, PL, PT, RO, RS, SE,

SI, SK, SM, TR), OAPI (BF, BJ, CF, CG, CI, CM, GA, GN, GQ, GW, KM, ML, MR, NE, SN, TD, TG).

Published:

— *with international search report (Art. 21(3))*

Description

Title of Invention: REFRIGERATOR

Technical Field

- [1] Embodiments of the present disclosure relate to a refrigerator including an inner door including an opening and an outer door which opens and closes the opening.

Background Art

- [2] Generally, refrigerators are home appliances which each include a storage compartment for storing food and a cool air supply device to keep food fresh for a long time.
- [3] A rack is provided in the storage compartment to put food thereon. The storage compartment may be provided to allow a front side thereof to be opened to put food in or take food out, and the open front side of the storage compartment may be opened and closed by a main door pivotably coupled with the a body. A door guard capable of storing food in addition to the rack disposed in the storage compartment may be provided on a rear side of the main door.
- [4] Since the door guard described above is provided at the rear side of the main door, generally, it is possible to approach the door guard by opening the main door. Meanwhile, there are refrigerators which include an additional auxiliary door provided at the main door in order to approach the door guard without opening the main door. In the case of refrigerators including the auxiliary door described above, since it is possible to approach the door guard provided at the rear side of the main door by opening only the auxiliary door, a diversity of food-storing options may increase and an effect of preserving cool air may be provided.

Disclosure of Invention

Technical Problem

- [5] Therefore, it is an aspect of the present disclosure to provide a refrigerator in which a control unit which controls an internal environment of a storage compartment of the refrigerator is installed at a main door and it is possible to approach the control unit provided at the main door by opening an auxiliary door and a method of manufacturing the refrigerator.
- [6] Additional aspects of the present disclosure will be set forth in part in the description which follows and, in part, will be obvious from the description, or may be learned by practice of the present disclosure.

Solution to Problem

- [7] In accordance with one aspect of the present disclosure, a refrigerator may include a body, a storage compartment formed in the body, an inner door which comprises an

opening corresponding to the storage compartment and is pivotably coupled with the body, an outer door disposed to be relatively pivotable from the inner door, and a control unit configured to control an internal environment of the storage compartment. A mounting portion on which the control unit is mounted may be provided at the inner door. The control unit may be mounted on the mounting portion.

[8] The control unit may include an operational portion and a display portion.

[9] The control unit may be configured to control a temperature, humidity, smell, lighting, etc. of the storage compartment.

[10] The control unit may include a circuit board which comprises an operational portion and a display portion, and a cover which covers the circuit board and comprises an opening which exposes a button portion operating on the operational portion and the display portion.

[11] The control unit may include a housing which accommodates the circuit board and the cover and is coupled with the mounting portion of the inner door.

[12] The control unit may include a transparent member which covers the cover and on which a function of the button portion is displayed.

[13] The inner door may include an upper frame, a lower frame, a left frame, and a right frame which form the opening. The control unit may be disposed on at least one of the upper frame, the lower frame, the left frame, and the right frame.

[14] The inner door may include an inner panel, an outer panel forming an interposing space with the inner panel, and an insulator foamed in the space. The control unit may be disposed between the inner panel and the outer panel.

[15] The refrigerator may further include a plurality of door guards provided at the inner door. The inner panel may include an inner wall which forms the opening and supports the plurality of door guards.

[16] The plurality of door guards each may include a front wall, a rear wall, both side walls, a bottom, and a storage space.

[17] The front wall of each of the plurality of door guards may form a part of a front side of the inner door.

[18] The outer door may include a transparent window provided for checking the control unit from the outside.

[19] The outer door may include a transparent or translucent material for checking the control unit from the outside.

[20] In accordance with another aspect of the present disclosure, a refrigerator may include a body, at least one storage compartment formed in the body, a plurality of doors which open and close the at least one storage compartment, and a control unit configured to control an internal environment of the at least one storage compartment. The plurality of doors may include a first door formed of a single door and a second

door formed of a dual door. The control unit may be disposed at the second door.

- [21] The second door may include an inner door which include an opening corresponding to the at least one storage compartment, an inner panel, and an outer panel with a space formed between the inner panel and the outer panel, and an insulator foamed in the space and is pivotably coupled with the body, and an outer door coupled to be relatively pivotable with respect to the inner door to open and close the opening. A mounting portion on which the control unit is mounted may be provided at the outer panel of the inner door. The control unit may be disposed in the space between the inner panel and the outer panel.
- [22] The outer door of the second door may include a transparent window provided for checking the control unit mounted on the inner door with the outer door closed.
- [23] The outer door of the second door may include a transparent or translucent material for checking the control unit mounted on the inner door with the outer door closed.
- [24] In accordance with one aspect of the present disclosure, a method of manufacturing an dual door of a refrigerator, which includes a body, a storage compartment formed in the body, the dual door pivotably coupled with the body for dually opening and closing the storage compartment, and a control unit configured for controlling an internal environment of the storage compartment, may include disposing the control unit at the dual door, injecting a bubble solution into an inner space of the dual door at which the control unit is disposed, and strongly coupling the control unit with the dual door by foaming the bubble solution.

Advantageous Effects of Invention

- [25] As is apparent from the above description, since a control unit is provided at an inner door of a dual door, a misoperation of a user may be prevented and contaminations caused by external foreign substances, etc. may be prevented. Also, since the control unit is operated by opening only an outer door of the dual door while the inner door is closed, it is possible to reduce thermal loss of a storage compartment while the control unit is operated. Also, by having the outer door be formed overall as a transparent window or providing a transparent window which allows displaying a portion of the control unit of the inner door for externally checking, environment setting condition of the storage compartment may be checked without opening the outer door.

Brief Description of Drawings

- [26] These and/or other aspects of the present disclosure will become apparent and more readily appreciated from the following description of the embodiments, taken in conjunction with the accompanying drawings of which:
- [27] FIG. 1 is a view of a refrigerator in accordance with one embodiment of the present disclosure in a state with both an inner door and an outer door closed;

- [28] FIG. 2 is a view illustrating a state with the inner door and the outer door of the refrigerator of FIG. 1 separately opened;
- [29] FIG. 3 is a view illustrating a state in which only the outer door of the refrigerator of FIG. 1 is opened;
- [30] FIG. 4 is a view illustrating a state with the inner door of the refrigerator of FIG. 1 is opened;
- [31] FIG. 5 is a view of the inner door and the door guards of the refrigerator of FIG. 1;
- [32] FIG. 6 is an exploded perspective view illustrating a configuration of the inner door of the refrigerator of FIG. 1;
- [33] FIG. 7 is an exploded perspective view from a different angle illustrating the configuration of the inner door of the refrigerator of FIG. 1;
- [34] FIG. 8 is an exploded perspective view of a control unit disposed at the inner door of the refrigerator of FIG. 1;
- [35] FIG. 9 is a partial cross-sectional view of the inner door of the refrigerator of FIG. 1;
- [36] FIG. 10 is a view of a refrigerator in accordance with another embodiment of the present disclosure in which a transparent window is provided at the outer door; and
- [37] FIG. 11 is a view of a refrigerator in accordance with still another embodiment of the present disclosure in which an outer door is totally formed with a transparent window.

Mode for the Invention

- [38] Hereinafter, exemplary embodiments of the present disclosure will be described in detail.
- [39] FIG. 1 is a view of a refrigerator in accordance with one embodiment of the present disclosure in a state with both an inner door and an outer door closed, FIG. 2 is a view illustrating a state with the inner door and the outer door of the refrigerator of FIG. 1 separately opened, FIG. 3 is a view illustrating a state in which only the outer door of the refrigerator of FIG. 1 is opened, and FIG. 4 is a view illustrating a state with the inner door of the refrigerator of FIG. 1 is opened.
- [40] Referring to FIGS. 1 to 4, a refrigerator 1 in accordance with the embodiment of the present disclosure includes a body 10, storage compartments 20 and 30 provided inside the body 10, and a cool air supply device which supplies cool air to the storage compartments 20 and 30.
- [41] The body 10 includes an inner casing 11 which has an approximately box shape and forms the storage compartments 20 and 30, an outer casing 12 which is coupled with an outside of the inner casing 11 and forms an exterior, and an insulator provided between the inner casing 11 and the outer casing 12. The inner casing 11 may be formed of a resin material, and the outer casing 12 may be formed of a metal material.
- [42] The cool air supply device may include a compressor (not shown), a condenser (not

shown), an expansion valve (not shown), and an evaporator (not shown) and may generate cool air using evaporating latent heat.

- [43] The storage compartments 20 and 30 may be divided into a freezing compartment 20 on the left and a refrigerating compartment 30 on the right by an intermediate wall 14. However, positions of the freezing compartment 20 and the refrigerating compartment 30 are changeable. Racks 31 on which food may be put are provided in the refrigerating compartment 30.
- [44] The freezing compartment 20 and the refrigerating compartment 30 may each have an open front side to allow putting food in or taking food out. The open front side of the freezing compartment 20 may be opened and closed by a freezing compartment door 21, and the open front side of the refrigerating compartment 30 may be opened and closed by a dual door formed of an outer door 100 and an inner door 200. As shown in the drawings, the freezing compartment door 21 is formed as a single door but may also be formed as a dual door.
- [45] The freezing compartment door 21 may be pivotably coupled with the body 10 by an upper hinge member 51 and a lower hinge member (not shown). The outer door 100 and the inner door 200 may also be pivotably coupled with the body 10 by an upper hinge member 52 and a lower hinge member (not shown). Particularly, the outer door 100 may be disposed to be relatively pivotable with respect to the inner door 200.
- [46] Here, although not shown in the drawings in detail, the outer door 100 and the inner door 200 may have different rotation axes or may share a single rotation axis.
- [47] The freezing compartment door 21, the outer door 100, and the inner door 200 may include handles 22, 101, and 201, respectively.
- [48] Meanwhile, the inner door 200 includes an opening 210 having a size approximately corresponding to a size of the refrigerating compartment 30 and a door frame 220 which forms the opening 210. Accordingly, the door frame 220 may have an approximately quadrangular frame shape.
- [49] The opening 210 includes a plurality of door guards 40 (which may also be referred to as a door bins) capable of storing food. The door guards 40 may generally store low-profile and small food items or food items which is frequently put in or taken out. The plurality of door guards 40 may be arranged in a row in a vertical direction at the opening 210.
- [50] A control unit 700 capable of controlling internal environments of the storage compartments 20 and 30 is disposed at the inner door 200. The control unit 700 may include a display portion 712 which displays environment information including temperature, humidity, smell, illuminance, etc. in the storage compartments 20 and 30 and an operational portion 711 for controlling temperature and humidity, deodorization, and setting illuminance, power saving, operation-locking, etc.

- [51] Although not shown in the drawings, the control unit 700 may be disposed in the freezing compartment door 21 formed of a single door. The outer door 100 does not include an opening and may have an approximately flat panel shape. Accordingly, the outer door 100 may open and close the opening 210 of the inner door 200.
- [52] Considering an operation of using the inner door 200 and the outer door 100 with a configuration described above in accordance with the one embodiment of the present disclosure, as shown in FIG. 1, when the inner door 200 and the outer door 100 are closed, the refrigerating compartment 30 may be sealed and cool air in the refrigerating compartment 30 may be preserved.
- [53] As shown in FIG. 3, when the inner door 200 is closed and only the outer door 100 is opened, a user may approach the plurality of door guards 40 and may put food into or take food out of the plurality of door guards 40. In this case, loss of cool air in the refrigerating compartment 30 may be reduced compared to the case for an open inner door 200.
- [54] Also, since the control unit 700 is not installed in the storage compartment 20 or 30 but is installed in the inner door 200, when the inner door 200 is closed and only the outer door 100 is opened, the user may approach the control unit 700 and control the internal environments of the storage compartments 20 and 30. Here, loss of cool air in the refrigerating compartment 30 may also be reduced compared to the case for an open inner door 200.
- [55] As shown in FIG. 4, when the inner door 200 is open, the user may approach an inside of the refrigerating compartment 30 and put in or take out food stored on the racks 31. Here, the user may approach the plurality of door guards 40 and put food into or take food out of the plurality of door guards 40.
- [56] As described above, in the case of the refrigerator 1 in accordance with one embodiment of the present disclosure, food may be put in or taken out by various methods according to the user's need. Also, since only the outer door 100 is opened when food stored in the plurality of door guards 40 is put in or taken out, loss of cool air may be minimized.
- [57] In addition, since the door guards 40 of the refrigerator 1 in accordance with one embodiment of the present disclosure have enlarged storage spaces compared to conventional door guards, a diversity of options for storing food and an effect of reducing loss of cool air may be enhanced.
- [58] Also, since the control unit 700 is installed at the inner door 200 and is not visible when the outer door 100 is closed, the refrigerator 1 in accordance with one embodiment of the present disclosure may have a clean and aesthetic external appearance. Since only the outer door 100 needs to be opened to change internal environment settings of the storage compartments 20 and 30, the loss of cool air may be minimized.

Also, the display portion 712 of the control unit 700 is turned on only when the outer door 100 is opened, thereby reducing power consumption.

[59] Detailed configurations of the inner door 200, the outer door 100, and the control unit 700 of the refrigerator 1 in accordance with one embodiment of the present disclosure will be described below.

[60] FIG. 5 is a view of the inner door and the door guards of the refrigerator of FIG. 1, FIG. 6 is an exploded perspective view illustrating a configuration of the inner door of the refrigerator of FIG. 1, and FIG. 7 is an exploded perspective view from a different angle illustrating the configuration of the inner door of the refrigerator of FIG. 1. FIG. 8 is an exploded perspective view of a control unit disposed at the inner door of the refrigerator of FIG. 1, and FIG. 9 is a partial cross-sectional view of the inner door of the refrigerator of FIG. 1.

[61] As is well shown in FIG. 5, the door guards 40 may have an approximately box shape. Accordingly, each of the door guards 40 may include a front wall 41, a rear wall 42, a left wall 43, a right wall 44, a bottom 45, and a storage space 46 which stores food. A supporting groove 47 may be formed at each of the left wall 43 and the right wall 44 of the door guard 40.

[62] The inner door 200 may include an inner wall 310 provided at each sides of the opening 210 to support the door guard 40. A supporting protrusion 330 to be inserted into the supporting groove 47 of the door guard 40 may protrude from the inner wall 310.

[63] Accordingly, the supporting protrusion 330 is inserted into the supporting groove 47, thereby the door guard 40 is mounted in the opening 210. The door guard 40 described above may be detached from the opening 210. Also, although not shown in the drawings, the door guard 40 may be provided to be slidable back and forth or up and down.

[64] Meanwhile, as is well shown in FIG. 6, the inner door 200 may include an inner panel 300, an outer panel 400 coupled with the inner panel 300 between which a foam space 500 (refer to FIG. 9) interposes, a plurality of installation members 600 coupled with a rear side of the inner panel 300 at which a gasket 650 (refer to FIG. 9) is installed, a plurality of reinforcing members 910 and 920 which prevent a twisting of the inner door 200, and a door trim 800 coupled between an end portion of the inner panel 300 and an end portion of the outer panel 400 to prevent a bubble solution foamed at the foam space 500 from leaking outward.

[65] The inner panel 300 may include an upper frame 301, a lower frame 302, a left frame 303, and a right frame 304 and may be formed of an integrally injection-molded resin material.

[66] The outer panel 400 may be formed of a metal material and may include an upper

frame 401, a lower frame 402, a left frame 403, and a right frame 404.

- [67] The inner panel 300 may include a pair of such inner walls 310 provided at both sides of the opening 210. The inner walls 310 may form the opening 210 and simultaneously may support the door guards 40.
- [68] Meanwhile, the door guards 40 may be disposed to be in contact with the outer door 100 of the opening 210 to allow the front wall 41 thereof to approximately form a part of a front side of the inner door 200.
- [69] By this structure, the door guards 40 may occupy the whole area of the opening 210, and a size thereof may be maximized. Also, since the door guards 40 are completely exposed when viewed from an outside of the inner door 200, a condition of food stored in the door guards 40 may be easily checked.
- [70] Meanwhile, as described above, the door guards 40 of the refrigerator 1 in accordance with one embodiment of the present disclosure may be provided at the opening 210 of the inner door 200 and may be not provided at a rear side of the outer door 100.
- [71] The outer door 100 may include an insulator provided between an inner panel 130 of the outer door 100 and an outer panel 120 of the outer door 100.
- [72] The inner panel 130 of the outer door 100 may be formed by vacuum-molding a resin material, and the outer panel 120 of the outer door 100 may include a metal material.
- [73] Meanwhile, the plurality of installation members 600 are for installing the gasket 650 at the inner panel 300 while minimizing use of a complicated mold including a slide core, etc. during an injection molding of the inner panel 300 and are coupled with a rear side rim of the inner panel 300.
- [74] The plurality of installation members 600, as is well shown in FIGS. 6 and 7, may include a first installation member 601 coupled with the upper frame 301 of the inner panel 300, a second installation member 602 coupled with the lower frame 302 of the inner panel 300, a third installation member 603 coupled with the left frame 303 of the inner panel 300, and a fourth installation member 604 coupled with the right frame 304 of the inner panel 300.
- [75] Here, the first installation member 601, the second installation member 602, the third installation member 603, and the fourth installation member 604 may be provided to be spaced apart rather than connected. Accordingly, the first installation member 601, the second installation member 602, the third installation member 603, and the fourth installation member 604 may be prevented from mutually interrupting by expansion due to heat.
- [76] As shown in FIG. 8, the control unit 700 may include a circuit board 710 which transmits a control signal according to an input of the user and displays internal environment information of the storage compartments 20 and 30. In detail, an operational

portion 711 of the circuit board 710 may recognize the input of the user, and the display portion 712 may display the internal environment information of the storage compartments 20 and 30.

[77] The circuit board 710 may further include a locking setting function for preventing a misoperation of the operational portion 711, a power-saving setting function for saving power of a refrigerator, etc. Recently, with the development of mobile communications, a wireless communication function capable of wirelessly operating settings of the refrigerator using a mobile device may be further included.

[78] The circuit board 710 may be contained in a housing 730 and may be fixed by a cover 720. The cover 720 may include a coupling hook 723 for coupling with the housing 730, and the housing 730 may include a hook holding portion 731 for coupling with the coupling hook of the cover 720.

[79] The cover 720 which covers the circuit board 710 of the control unit 700 may include a button portion 721 which operates on the operational portion 711 of the circuit board 710 and an opening 722 provided to expose the display portion 712. The user may input desired settings into the operational portion 711 of the circuit board 710 by pressurizing the button portion 721. Since the display portion 712 of the circuit board 710 is exposed through the opening 722 of the cover 720, the user may check environment information displayed on the display portion 712 even when the circuit board 710 is covered with the cover 720.

[80] The control unit 700 may be disposed in a space between the outer panel 400 and the inner panel 300 of the inner door 200 and may be mounted on the outer panel 400. The outer panel 400 of the inner door 200 may include the upper frame 401, the lower frame 402, the left frame 403, and the right frame 404, and at least one of among them may be provided with a mounting portion 410 for mounting the control unit 700.

[81] The housing 730 of the control unit 700 may include a coupling hook 732 to be coupled with the mounting portion 410. The housing 730 may include a cable connecting portion 733 for connecting a cable to the circuit board 710 accommodated therein.

[82] The mounting portion 410 may include a hook holding portion 412 capable of being coupled with the coupling hook 732 of the housing 730 and may include an opening 411 to expose the cover 720 of the control unit 700.

[83] The control unit 700 may further include a transmission member (which may also be referred to as a transparent member) 740 for finishing of the cover 720. Since the transmission member 740 is an outermost component of the control unit 700, the transmission member 740 may not only have a function of preventing foreign substances from penetrating the control unit 700 but also an aesthetic function. Accordingly, not only a function of the button portion 721 corresponding to the button

portion 721 of the cover 720 but also other elements of design may be printed on the transmission member 740.

- [84] The transmission member 740 may be formed of a material through which light shown on the display portion 712 of the circuit board 710 may pass and may be formed of a flexible resin material to pressurize the button portion 721. The transmission member 740 may include an adhesive layer formed on a rear side thereof to be adhered to the cover 720.
- [85] Meanwhile, the door trim 800 is for preventing the bubble solution in the foam space 500 between the inner panel 300 and the outer panel 400 from leaking outward. As shown in FIG. 9, the door trim 800 may include an insertion groove in which an end portion 311 of the inner wall 310 of the inner panel 300 is press fittingly inserted and an insertion groove in which an end portion 405 of the outer panel 400 is press fittingly inserted. Also, a coupling groove in which a coupling protrusion 406 of the outer panel 400 is inserted may be formed to reinforce a coupling force between the door trim 800 and the outer panel 400. A foaming process of the inner door 200 including the door trim 800 is as follows.
- [86] First, the control unit 700 is disposed at the mounting portion 410 of the outer panel 400. The housing 730 of the control unit 700 and the outer panel 400 are sealed not to allow the bubble solution to penetrate. Also, the cable connecting portion 733 provided to connect the cable to the circuit board 710 accommodated in the housing 730 may also be sealed.
- [87] Next, the inner panel 300, the outer panel 400, and the door trim 800 are preliminarily coupled, the inner panel 300 is disposed to face a bottom surface, and the outer panel 400 is disposed to face upward, and then the inner panel 300 and the outer panel 400 are pressurized in a vertical direction F using a fixing jig (not shown).
- [88] Then, the bubble solution is inserted into the foam space 500 formed between the inner panel 300 and the outer panel 400 for foaming. Here, since the inner panel 300 and the outer panel 400 are pressurized in the vertical direction F, the inner panel 300 and the outer panel 400 are not forced apart due to a foaming pressure in the vertical direction F. Accordingly, the bubble solution may not leak in the vertical direction.
- [89] Also, since the door trim 800 tightly holds the end portion of the inner panel 300 and the end portion of the outer panel 400, the inner panel 300 and the outer panel 400 are not forced apart by a foaming pressure in a horizontal direction, and the bubble solution may not leak.
- [90] Without the door trim 800, even though the inner panel 300 and the outer panel 400 next to the opening 210 are provided to overlap with each other, the bubble solution may leak through a gap formed due to a foaming pressure,.
- [91] When foaming of the bubble solution for foaming in the foam space formed between

the inner panel 300 and the outer panel 400 is completed, the inner panel 300, the outer panel 400, and the door trim 800 may be strongly coupled and the control unit 700 may also be strongly coupled with the outer panel 400 by an adhesive force of the bubble solution.

- [92] Meanwhile, the inner door 200 of the refrigerator 1 in accordance with one embodiment of the present disclosure is vulnerable to a twisting due to the opening 210. Also, a twisting may occur or the inner wall 310 may be not formed even due to a foaming pressure in a foaming process of the inner door 200. The plurality of reinforcing members 910 and 920 may be provided at the inner door 200 to overcome the above described vulnerability.
- [93] The plurality of reinforcing members 910 and 920 may include a first reinforcing member 910 which crosses the opening 210 and connects the left frame 303 of the inner panel 300 with the right frame 304 of the inner panel 300 and a second reinforcing member 920 provided at the upper frame 301 of the inner panel 300, the lower frame 302 of the inner panel 300, the left frame 303 of the inner panel 300, and the right frame 304 of the inner panel 300.
- [94] The second reinforcing member 920 may include an upper reinforcing portion 921, a lower reinforcing portion 922, a left reinforcing portion 923, and a right reinforcing portion 924 and may be provided in an approximate quadrangular frame shape. The second reinforcing member 920 may be integrally formed of a metal material having hardness.
- [95] As shown in FIG. 9, an accommodating space 350 which accommodates the second reinforcing member 920 and the hook portion 351 which fixes the second reinforcing member 920 may be formed at the inner panel 300. Accordingly, the second reinforcing member 920 may be coupled with the inner panel 300 and may be disposed between the inner panel 300 and the outer panel 400. Accordingly, the second reinforcing member 920 may be not exposed to the outside.
- [96] The second reinforcing member 920 may be fixed to the inner panel 300 before the bubble solution is foamed in the foam space formed between the inner panel 300 and the outer panel 400.
- [97] The first reinforcing member 910 prevents the twisting of the inner door 200 by directly connecting the relatively long left frame 303 of the inner panel 300 and the right frame 304 of the inner panel 300 across the opening 210. The second reinforcing member 920 is provided at each of the upper frame 301 of the inner panel 300, the lower frame 302 of the inner panel 300, the left frame 303 of the inner panel 300, and the right frame 304 of the inner panel 300 to reinforce four sides, thereby preventing the twisting of the inner door 200.
- [98] However, although both the first reinforcing member 910 and the second reinforcing

member 920 are provided in the embodiment of the present disclosure, only one of the first reinforcing member 910 and the second reinforcing member 920 may be provided as necessary.

[99] FIG. 10 is a view of a refrigerator in accordance with another embodiment of the present disclosure in which a transparent window is provided at the outer door.

[100] Referring to FIG. 10, a transparent window 750 may be provided at the outer door 100 of the refrigerator 1 for checking the display portion 712 of the control unit 700 with the outer door 100 closed. With the outer door 100 closed, the transparent window 750 is provided at a position corresponding to a position of the control unit 700 disposed at the inner door 200. The transparent window 750 is provided to be through both the outer panel 120 and the inner panel 130 of the outer door 100.

[101] When the control unit 700 is manufactured using an electrostatic touch panel, the transparent window 759 may be formed of a conductive material for operating the control unit 700 even with the outer door 100 closed.

[102] FIG. 11 is a view of a refrigerator in accordance with still another embodiment of the present disclosure in which an outer door is totally formed with a transparent window.

[103] Referring to FIG. 11, the outer door 100 may be formed of a transparent or translucent material to check not only the control unit 700 but also an inside of the refrigerating compartment 30 with the outer door 100 closed. As shown in FIG. 11, the entire outer door 100 may be formed of the transparent or translucent material, or a part of the outer door 100 may be formed of the transparent or translucent material.

[104] In detail, both the outer panel 120 and the inner panel 130 of the outer door 100 may be formed of a transparent or translucent panel 140 including a glass material, etc. and an insulating layer including an air layer, etc. may be included between panels. Also, there may be formed a single transparent panel 140.

[105] When the control unit 700 is manufactured using an electrostatic touch panel, the transparent panel 140 may be formed of a conductive material for operating the control unit 700 even with the outer door 100 closed.

[106] Although a few embodiments of the present disclosure have been shown and described, it would be appreciated by those skilled in the art that changes may be made in these embodiments without departing from the principles and spirit of the present disclosure, the scope of which is defined in the claims and their equivalents.

Claims

- [Claim 1] A refrigerator comprising:
a body;
a storage compartment formed in the body;
an inner door comprising an opening corresponding to the storage compartment and pivotably coupled with the body;
an outer door disposed to be pivotable from and relative to the inner door;
a mounting portion provided on the inner door; and
a control unit configured to control an internal environment of the storage compartment, and mounted on the mounting portion.
- [Claim 2] The refrigerator of claim 1, wherein the control unit comprises an operational portion and a display portion.
- [Claim 3] The refrigerator of claim 1, wherein the control unit is configured to control at least one of a temperature, humidity, smell, and lighting of the storage compartment.
- [Claim 4] The refrigerator of claim 1, wherein the control unit comprises:
a circuit board comprising an operational portion and a display portion;
and
a cover covering the circuit board, the cover comprising a button portion to operate on the operational portion and an opening which exposes the display portion.
- [Claim 5] The refrigerator of claim 4, wherein
the control unit comprises a housing which accommodates the circuit board and the cover, and
the housing is coupled with the mounting portion of the inner door.
- [Claim 6] The refrigerator of claim 4, wherein the control unit comprises a transparent member which covers the cover and on which a function of the button portion is displayed.
- [Claim 7] The refrigerator of claim 1, wherein
the inner door comprises an upper frame, a lower frame, a left frame, and a right frame which form the opening, and
the control unit is disposed on at least one of the upper frame, the lower frame, the left frame, and the right frame.
- [Claim 8] The refrigerator of claim 1, wherein
the inner door comprises an inner panel, an outer panel forming an interposing space with the inner panel, and an insulator foamed in the in-

- terposing space, and
the control unit is disposed between the inner panel and the outer panel.
- [Claim 9] The refrigerator of claim 8, further comprising a plurality of door guards provided on the inner door, wherein the inner panel comprises an inner wall which forms the opening and supports the plurality of door guards.
- [Claim 10] The refrigerator of claim 9, wherein each of the plurality of door guards comprises a front wall, a rear wall, two side walls, a bottom, and a storage space.
- [Claim 11] The refrigerator of claim 10, wherein the front wall of each of the plurality of door guards forms a part of a front side of the inner door.
- [Claim 12] The refrigerator of claim 1, wherein the outer door comprises a transparent window permitting the control unit to be viewed from an outside.
- [Claim 13] The refrigerator of claim 1, wherein the outer door comprises a transparent or translucent material permitting the control unit to be viewed from an outside.

[Fig. 1]

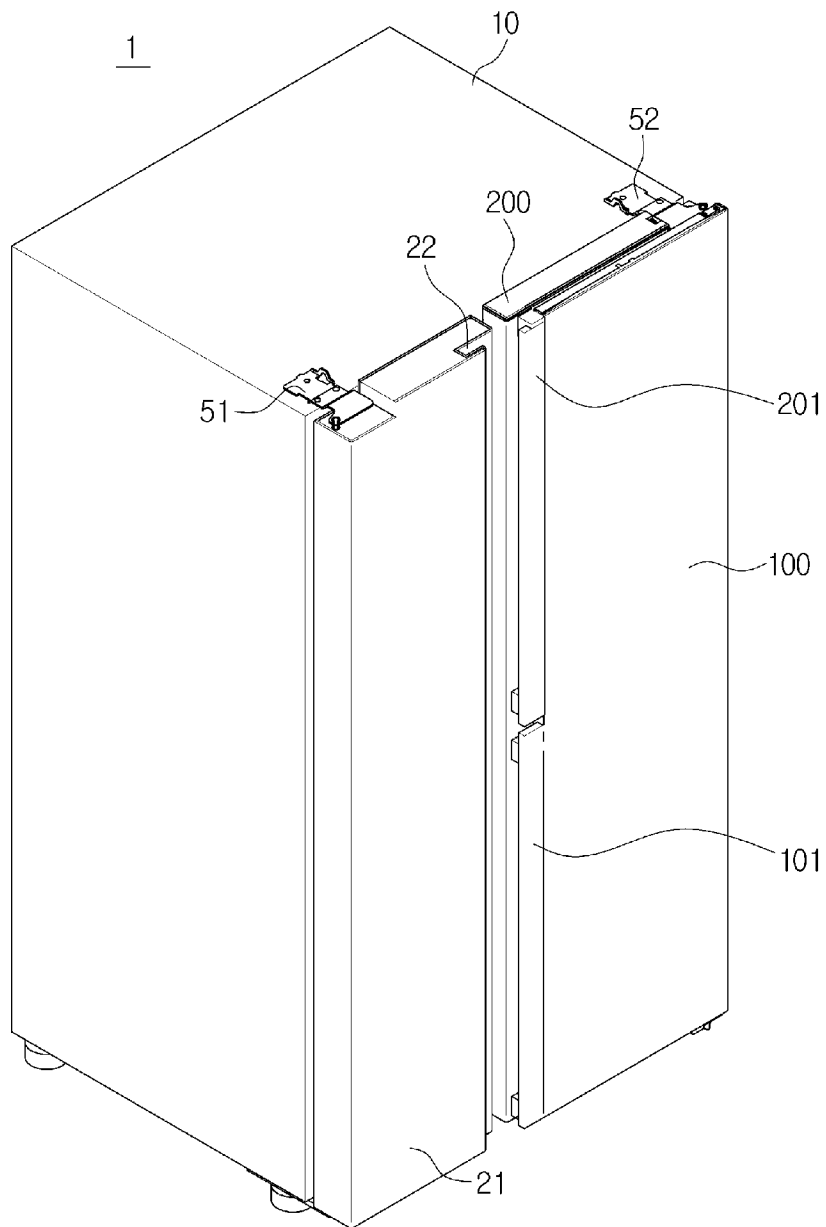

[Fig. 6]

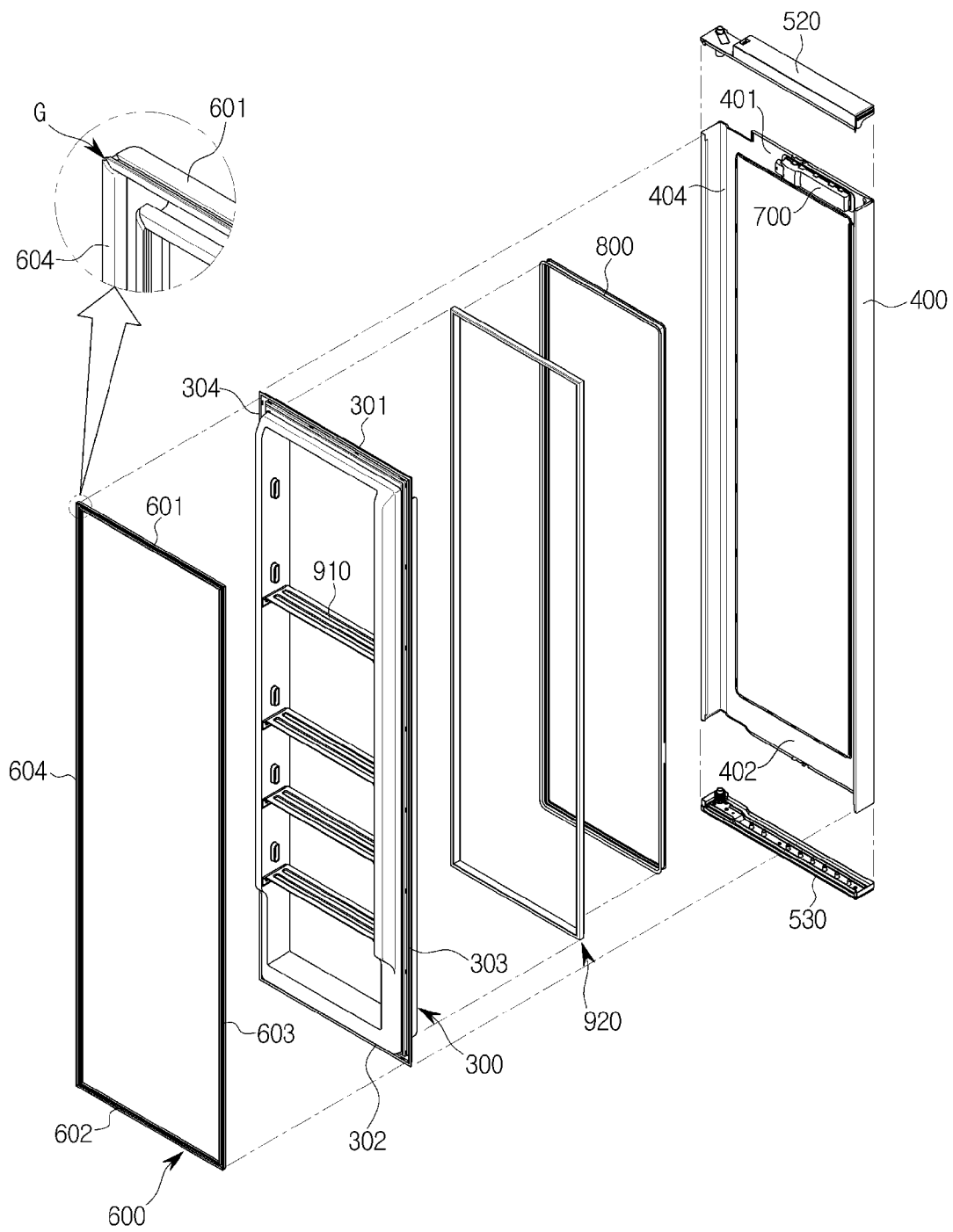

[Fig. 7]

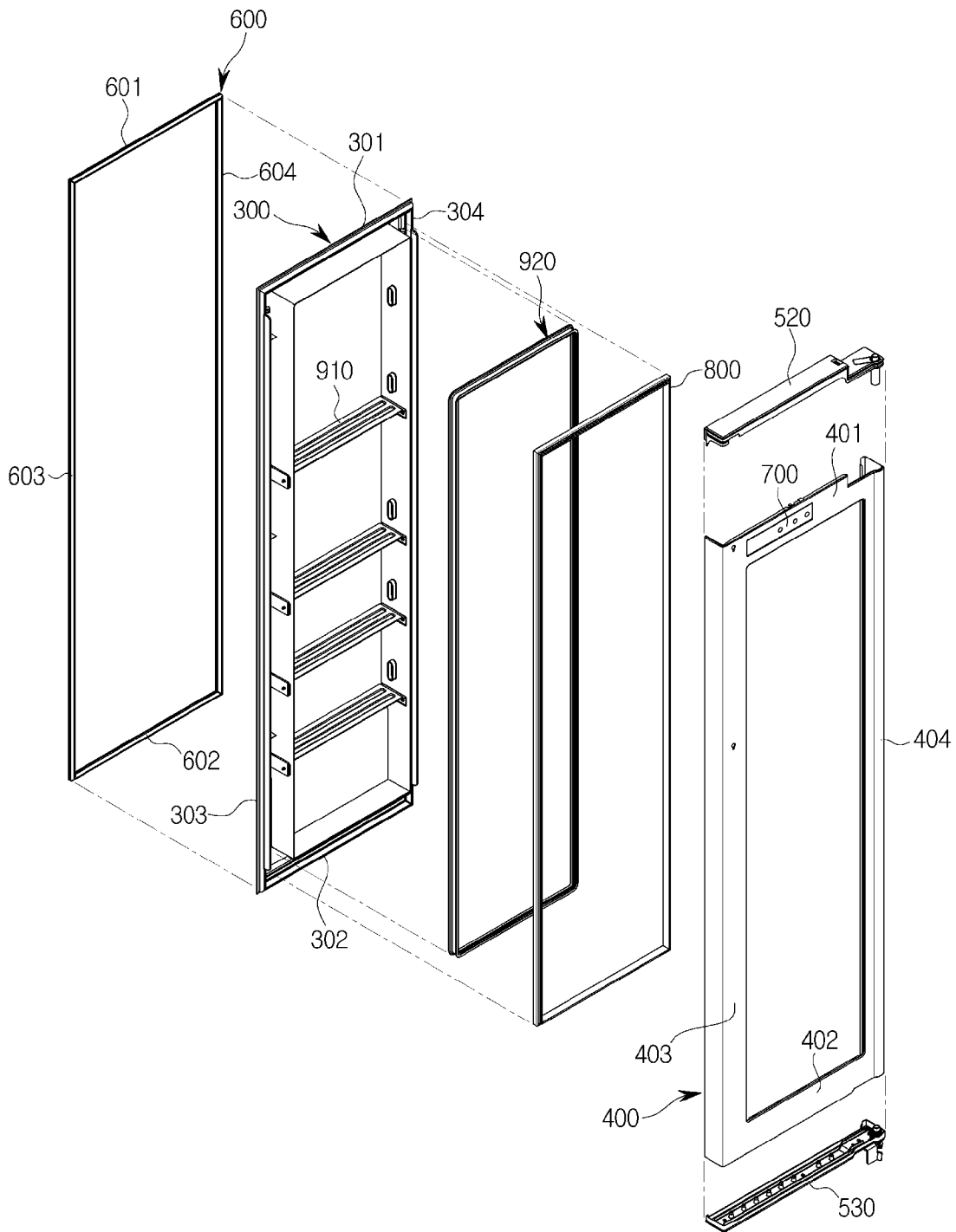

[Fig. 8]

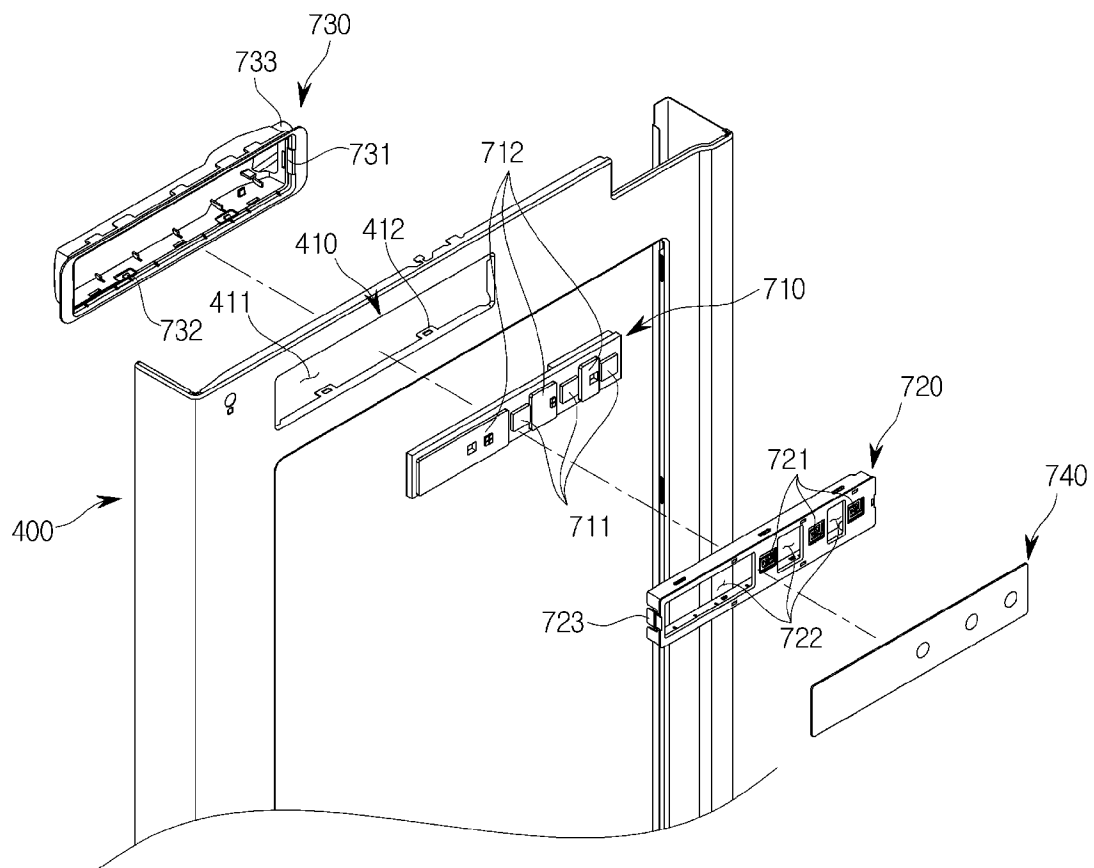

[Fig. 9]

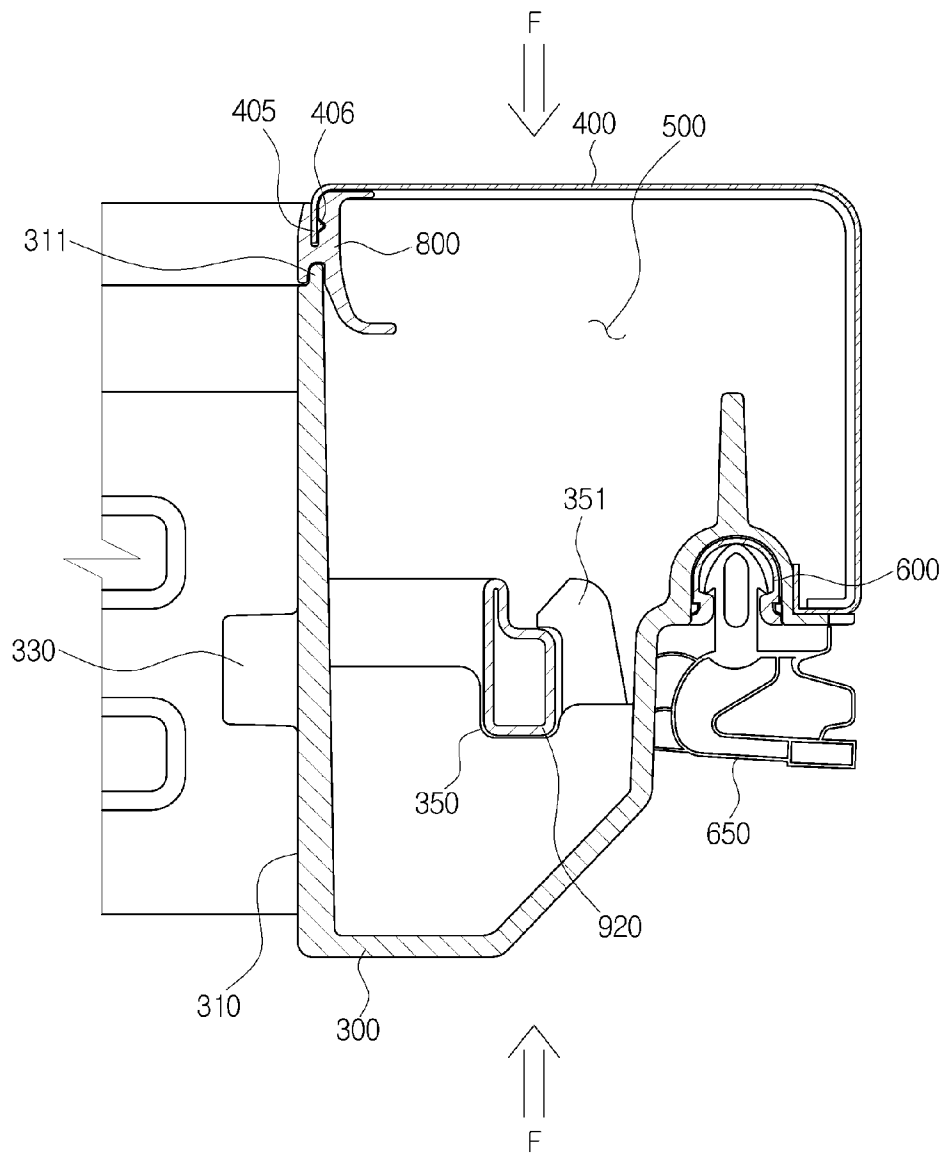

[Fig. 10]

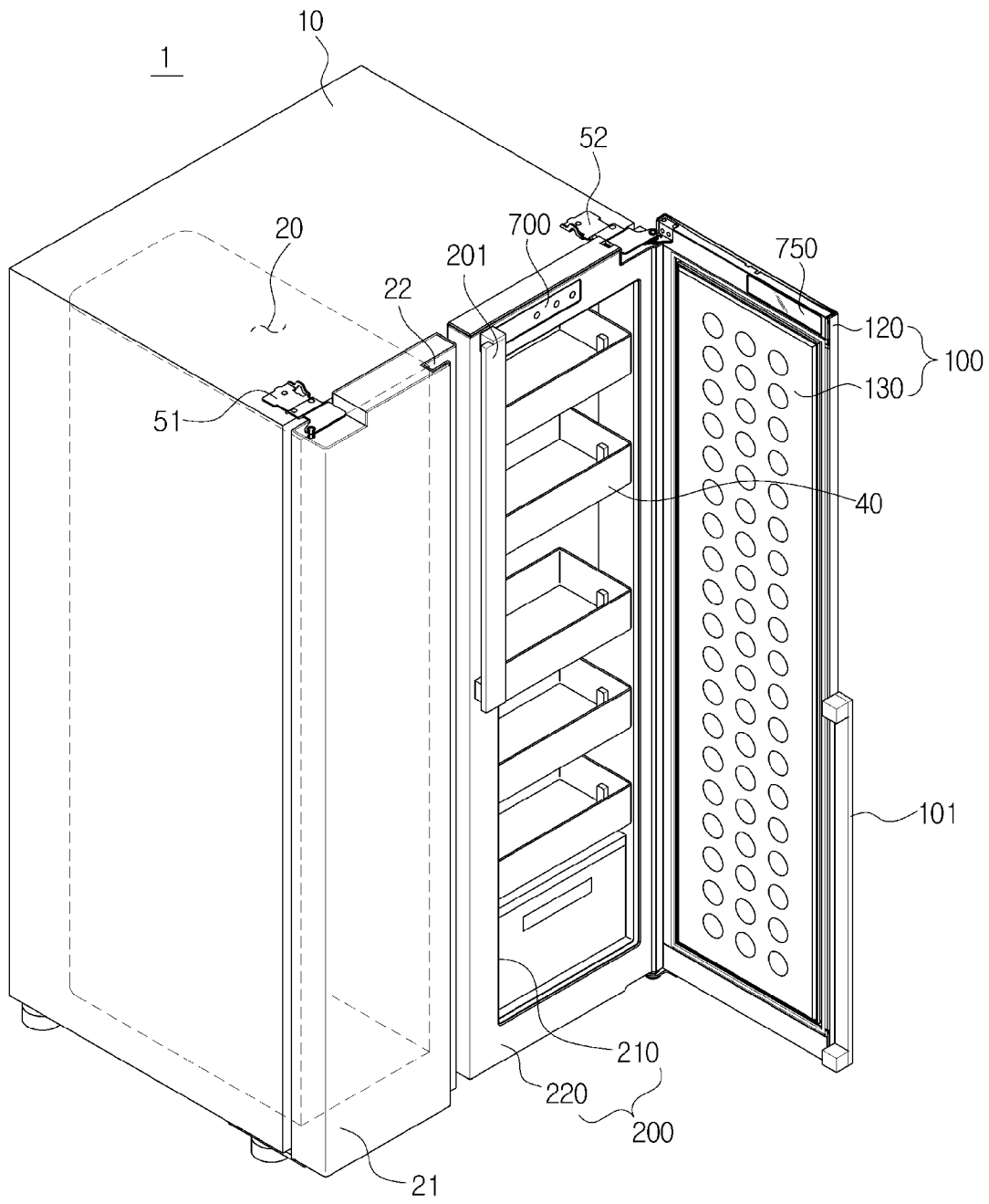

A. CLASSIFICATION OF SUBJECT MATTER**F25D 23/02(2006.01)I, F25D 29/00(2006.01)I, F25D 23/06(2006.01)I**

According to International Patent Classification (IPC) or to both national classification and IPC

B. FIELDS SEARCHED

Minimum documentation searched (classification system followed by classification symbols)

F25D 23/02; F25D 23/06; F25D 11/02; H05B 37/02; F25D 23/04; F03G 7/06; F25D 21/06; F25D 25/02; F25D 27/00; F25D 29/00

Documentation searched other than minimum documentation to the extent that such documents are included in the fields searched

Korean utility models and applications for utility models

Japanese utility models and applications for utility models

Electronic data base consulted during the international search (name of data base and, where practicable, search terms used)

eKOMPASS(KIPO internal) & Keywords: refrigerator, inner, door, control unit, cover, transparent, frame, and mount

C. DOCUMENTS CONSIDERED TO BE RELEVANT

Category*	Citation of document, with indication, where appropriate, of the relevant passages	Relevant to claim No.
Y	KR 10-2014-0060431 A (SAMSUNG ELECTRONICS CO., LTD.) 20 May 2014 See paragraphs [0028]-[0036], [0045]-[0049] and figures 2, 3, 5, 8.	1-13
Y	US 2010-0319390 A1 (LEE, SEUNG-MOK) 23 December 2010 See paragraphs [0043], [0053], [0054] and figures 2, 3.	1-13
Y	US 5442933 A (UNGER, LARRY E.) 22 August 1995 See column 5, lines 12-39 and figure 5.	4-6
Y	US 2015-0040604 A1 (LG ELECTRONICS INC.) 12 February 2015 See paragraph [0041] and figure 7.	12, 13
A	US 2009-0284157 A1 (WETEKAMP, ROBERT L.) 19 November 2009 See paragraph [0014] and figure 1.	1-13

 Further documents are listed in the continuation of Box C. See patent family annex.

* Special categories of cited documents:

"A" document defining the general state of the art which is not considered to be of particular relevance

"E" earlier application or patent but published on or after the international filing date

"L" document which may throw doubts on priority claim(s) or which is cited to establish the publication date of another citation or other special reason (as specified)

"O" document referring to an oral disclosure, use, exhibition or other means

"P" document published prior to the international filing date but later than the priority date claimed

"T" later document published after the international filing date or priority date and not in conflict with the application but cited to understand the principle or theory underlying the invention

"X" document of particular relevance; the claimed invention cannot be considered novel or cannot be considered to involve an inventive step when the document is taken alone

"Y" document of particular relevance; the claimed invention cannot be considered to involve an inventive step when the document is combined with one or more other such documents, such combination being obvious to a person skilled in the art

"&" document member of the same patent family

Date of the actual completion of the international search

12 September 2016 (12.09.2016)

Date of mailing of the international search report

12 September 2016 (12.09.2016)

Name and mailing address of the ISA/KR

International Application Division

Korean Intellectual Property Office

189 Cheongsa-ro, Seo-gu, Daejeon, 35208, Republic of Korea

Facsimile No. +82-42-481-8578

Authorized officer

HAN, JOONG SUB

Telephone No. +82-42-481-3578



INTERNATIONAL SEARCH REPORT

Information on patent family members

International application No.

PCT/KR2016/006949

Patent document cited in search report	Publication date	Patent family member(s)	Publication date
KR 10-2014-0060431 A	20/05/2014	EP 2730869 A2	14/05/2014
		US 2014-0132146 A1	15/05/2014
		US 9091476 B2	28/07/2015
US 2010-0319390 A1	23/12/2010	CN 101883961 A	10/11/2010
		CN 101883961 B	01/02/2012
		CN 102384635 A	21/03/2012
		CN 102519202 A	27/06/2012
		EP 2223028 A1	01/09/2010
		KR 10-0894479 B1	22/04/2009
		WO 2009-069957 A1	04/06/2009
US 5442933 A	22/08/1995	AU 5030493 A	12/05/1994
		CA 2108620 A1	03/05/1994
		JP 06-201240 A	19/07/1994
		JP 3457981 B2	20/10/2003
		KR 10-0144443 B1	01/08/1998
		NZ 248935 A	26/10/1995
		US 5473911 A	12/12/1995
		US 5474213 A	12/12/1995
		US 5526854 A	18/06/1996
US 2015-0040604 A1	12/02/2015	CN 104374137 A	25/02/2015
		EP 2837902 A2	18/02/2015
		EP 2837902 A3	27/05/2015
		KR 10-2015-0018962 A	25/02/2015
US 2009-0284157 A1	19/11/2009	US 2007-0157638 A1	12/07/2007
		US 7568358 B2	04/08/2009
		US 7921658 B2	12/04/2011