

[54] PROCESS FOR WINDING A COIL ON A REED SWITCH HAVING COIL FORM MEANS MOUNTED ON THE SWITCH CAPSULE

Primary Examiner—R. N. Envall, Jr.
Attorney, Agent, or Firm—Molinare, Allegretti, Newitt & Witcoff

[75] Inventor: Richard L. Collette, Hoffman Estates, Ill.

[73] Assignee: Guardian Electric Manufacturing Company, Chicago, Ill.

[22] Filed: Aug. 21, 1973

[21] Appl. No.: 390,316

[57] ABSTRACT

A coil is wound about an elongated glass capsule of a reed switch and held between plastic tubes attached to each end of the capsule. The plastic tubes extend over the opposite ends of the capsule and may be glued or fitted thereon. Flanges extend outward from the tubes and the coil is then wrapped on the capsule where it is maintained in position by the flanges. Outward extensions of the tubes protect the leads of the reed switch and correct concentricity tolerances on the glass capsule allowing use of conventional coil winding apparatus.

[52] U.S. Cl. 335/154

[51] Int. Cl. H01h 51/28

[58] Field of Search 335/151, 152, 153, 154

[56] References Cited

UNITED STATES PATENTS

3,444,492 5/1969 Swiderski..... 335/154 X

FOREIGN PATENTS OR APPLICATIONS

6,704,093 9/1967 Netherlands..... 335/151

8 Claims, 5 Drawing Figures

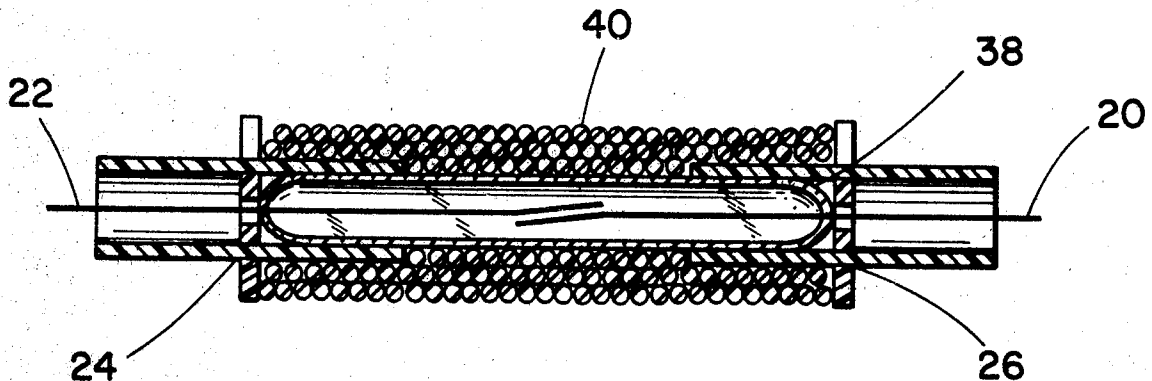

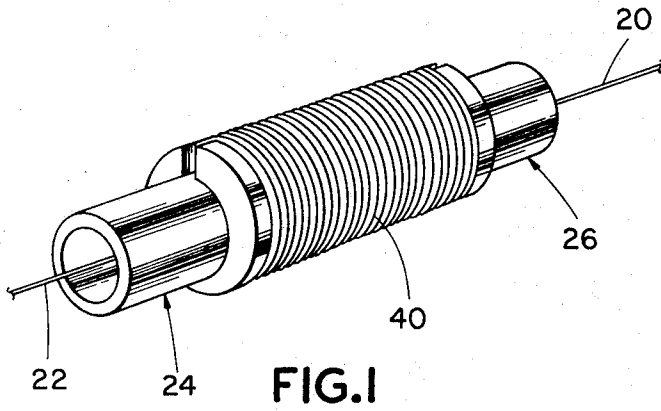

FIG. 1

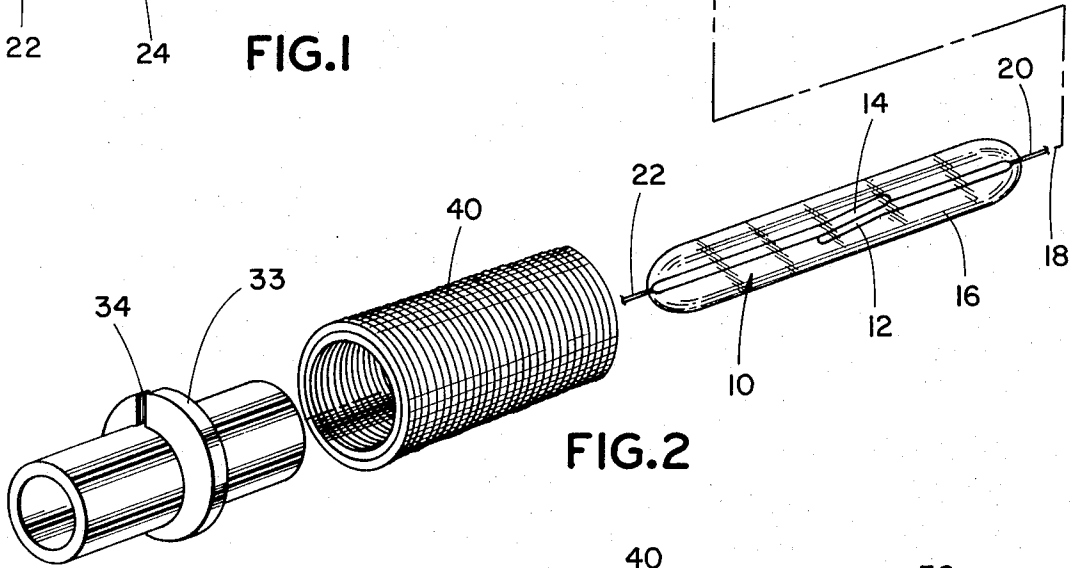
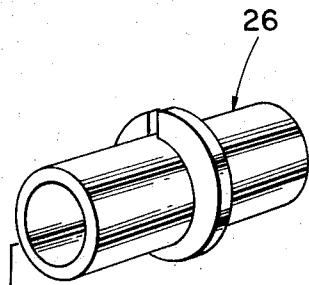

FIG. 2

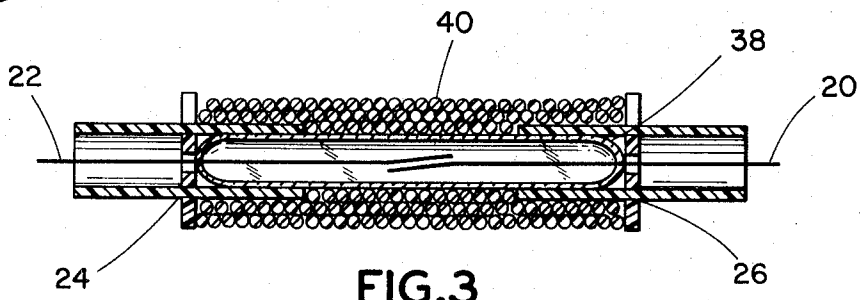

FIG. 3

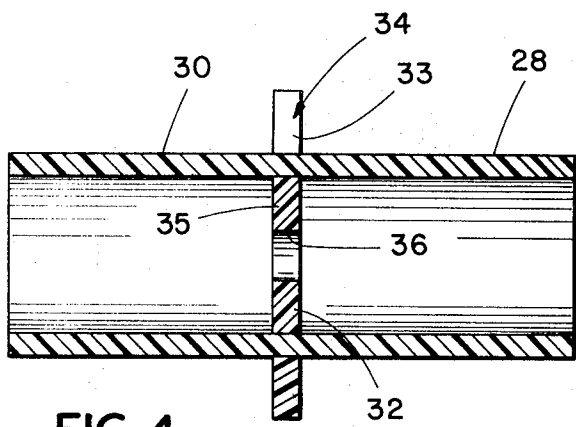

FIG. 4

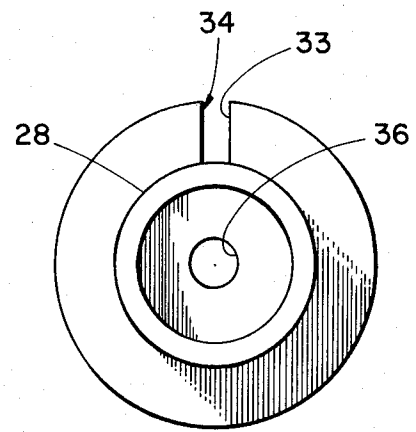

FIG. 5

PROCESS FOR WINDING A COIL ON A REED SWITCH HAVING COIL FORM MEANS MOUNTED ON THE SWITCH CAPSULE

BACKGROUND OF THE INVENTION

The present invention relates to an improved encapsulated switch device and in particular to means for positioning and maintaining a coil about an encapsulated reed switch.

It is often desirable to utilize a coil positioned about a glass encapsulated reed switch to effect the switching operation of the reed switch. By passing a current through the coil, the contacts on the interior of the encapsulated switch may be moved to make or break a circuit.

A common method presently used to provide a coil about the elongated capsule of a reed switch calls for winding a coil on a separate tube having a very thin wall. The reed capsule may then be placed within the tube. A very thin walled tube is desired in order to position the coil closely adjacent the capsule wall. However, as a result of manufacturing tolerances for the glass capsule, finished coil and tube, sufficient clearances dictate a loss in sensitivity of the device. Also, the thin walled tube within which the reed switch is positioned requires an expensive precision molding device or procedure. Finally, a bondable wire and bonding process may be required to fuse the wires of the coil together so that the coil will not collapse.

Recently, it has been suggested that plastic flanges be attached directly to the reed switch capsule. These flanges have an opening through the center into which the reed switch is fitted. An adhesive material is required to attach the circular flange to the reed switch capsule. Alignment apparatus is also required to maintain the flange perpendicular to the reed switch housing while the adhesive is dried. Finally, this method is not subject to a truly automatic coil winding operation.

While these various prior art devices give adequate performance, they are generally expensive, time consuming to make and less efficient than desired. Thus, the present invention was conceived to overcome various limitations of the prior art.

SUMMARY OF THE INVENTION

In a principal aspect, the present invention comprises a coil construction wherein an elongated switch housing includes specially constructed tube members attached to the opposite ends. The tube members each include a first inward extension with an opening to receive an outside end wall of the switch. A flange is defined on each member transverse to the longitudinal axis of the switch device. The flanges hold a coil on the switch.

Thus, it is an object of the present invention to provide an improved structure combining a coil with an enclosed switch device.

A further object of the present invention is to provide a construction wherein a coil may be wound in direct contact with the enclosure wall of an encapsulated switch device.

Another object of the present invention is to provide a coil construction for a reed switch which does not require bondable wire or a precision molded tube onto which a coil of material will be wound.

One further object of the present invention is to provide a construction which is symmetrical thus permit-

ting ease and assembly of a coil in combination with an encapsulated switch.

Still another object of the present invention is to provide a structure which is used in combination with an encapsulated switch to provide protection to the ends of the switch capsule while also providing means for maintaining the coil on the capsule as well as providing a concentric mounting means for spinning the capsule during coil winding.

These and other objects, advantages and features of the present invention will be set forth in the detailed description which follows.

BRIEF DESCRIPTION OF THE DRAWING

In the detailed description which follows, reference will be made to the drawing comprised of the following Figures:

FIG. 1 is a perspective view of the improved structure of the present invention;

FIG. 2 is an exploded perspective view of the structure of FIG. 1;

FIG. 3 is a cross-sectional view along the longitudinal axis of the structure shown in FIG. 1;

FIG. 4 is an enlarged cross-sectional view of a typical plastic tube member as utilized with the structure of the present invention; and

FIG. 5 is an end view of the tube members shown in FIG. 4.

DESCRIPTION OF THE PREFERRED EMBODIMENT

The structure of the present invention contemplates utilization of a reed switch device as illustrated at 10 in FIG. 2. Typically the reed switch includes contact members 12 and 14 which are maintained within a glass capsule 16 having a longitudinal axis 18. The leads 12 and 14 extend beyond the glass capsule 16 and terminate as external leads 20 and 22 respectively. Thus, the encapsulated reed switch 10 is of the type well known in the art and is described herein by way of example since the invention contemplates a combination of structural elements which may include switch devices other than the type described herein as a glass encapsulated reed switch.

Affixed to the opposite ends of the reed switch 10 are plastic tube members or bobbins 24 and 26, as they will be referred to in this specification. These plastic bobbins 24 and 26 permit fabrication of the claimed structure. Each bobbin 24 and 26, as illustrated in FIGS. 4 and 5, is comprised of an inward extension 28, which in the embodiment illustrated is cylindrical and hollow. The extension 28 slides over the outer end of the reed capsule 10 as illustrated in FIG. 3.

Extending in the opposite direction from the extension 28 is an outward extension 30. The extensions 28 and 30 together form a uniform diameter hollow tube separated into two parts by a flange 32 which is perpendicular to the longitudinal axis of extensions 28 and 30. Flange 32 has an outer portion 33 and an inner annular portion 35 both of which extend circumferentially about the tubular extensions 28 and 30. In the embodiment disclosed, a slot 34 is defined in the portion 33 of flange 32 outside of extensions 28 and 30.

In the embodiments shown, the extensions 28 and 30 are of equal dimension. The extension 28 also has an inside diameter approximately equal to the outside diameter of the capsule 10. In this manner, the bobbin 26

may be positioned snugly over the end of the capsule 10.

The flange portion 35 which extends on the inside surface of the extensions 28 and 30 includes an opening 36 defined at the center of the bobbin 26. This opening 36 permits lead 22 of the capsule 10 to pass there-through for connection with a wire. Note that the lead 22 will be protected by the outer extension 30. This is an important aspect of the invention.

The bobbins 24 and 26 may be fastened to the capsule 10 by an adhesive 38. Of course, other means may be utilized to attach the bobbins 24 and 26 to the capsule 10. For example, the bobbin 24 and, in particular, the extension 28 may be shrink fitted onto the capsule.

Importantly, the extensions 28 of bobbins 24 and 26 leave an exposed area of glass, particularly in the vicinity of the separated contact members 12 and 14. Thus, a coil 40 of wire may be wrapped directly about the glass of the capsule 10 and retained between flanges 32. In this manner, the coil 40 is in intimate contact with the surface of the enclosure 16.

Additionally, it is not necessary to bond the wires comprising the coils 40. The flange 32 retains the wire of coil 40 in position. This improves the sensitivity to a near optimum level since there is no air gap between the copper of the coil and the glass envelope. Also, it enables production of a coil and reed assembly with the optimum of miniaturization.

It should be noted that the bobbins are preferably symmetrical and thus assembly of the device need not rely upon any particular orientation of the bobbins relative to any particular end of the glass envelope 16. It is also noted that the glass seal of capsule 10 is protected during the coil winding operation because the leads 20 and 22 are enclosed within the extensions 30.

In the preferred embodiment, the flanges 32 are substantially perpendicular to the longitudinal axis 18. Also, the outer extension 30 provides a means to hold the capsule 10 as the coil winding device winds a coil 40 on the capsule without disturbing the glass seal of the leads in the capsule 10. It is possible to wind a longer coil 40 onto the capsule 10 because of the additional space provided by the inward extensions 28. A longer coil 40 improves the sensitivity of the device but does not increase the overall size of the relay since the coil 40 actually extends only between the opposite ends of the capsule 16.

It is also possible with this assembly to extend the coil 40 beyond the ends of the capsule 16. This may be done by positioning the outer portion 33 of the flange 32 outward along the extension 30. It is also possible to vary the construction of the invention in many other ways. For example, bobbins may be constructed to cooperate with a plurality of capsules. Then a single coil could be wound around all of those capsules. Additionally, bobbins could be constructed wherein the extensions 28 and 30 have different shapes, diameters or other dimensional characteristics relative to each other.

To fabricate the device, the bobbins are first placed at the end of the capsule and the leads extending from the capsule are placed through the bobbin and trimmed preferably to be within the protective enclosure of the outer extension 30. The assembly is then placed onto

a winding machine and supported by the bobbins 24, 26.

Note that the outer extensions 28 and 30 serve to properly align the assembly in a centered or concentric fashion on a coil winding machine thus accomodating any irregularities in the capsule. The bobbin machine is then operated to wind the coil 40 between the flanges 32. The leads to coil 40 fit through slot 34. As another feature, the outer extensions 28 and 30 may then be removed to expose the previously protected leads 20 and 22.

While in the foregoing there has been set forth a preferred embodiment of the invention, it is to be understood that the invention shall be limited only by the following claims and their equivalents.

What is claimed is:

1. An improved coil and switch structure comprising in combination:

a switch device encapsulated in a generally elongated housing, said switch device including lead means responsive to a change in magnetic field to make and break a circuit,

first and second tube member means affixed to opposite ends of said housing, each of said tube member means including an extension with an opening for matched fit receipt of said end of said housing, flange means extending outward from said extension transverse to the longitudinal dimension of said elongated housing, a passage through said tube member means for a lead to the interior of said housing, and

a coil wrapped on said housing and maintained thereon by said first and second tube member means.

2. The improved structure of claim 1 wherein said first and second tube member means each include an additional extension outwardly from said flange means in the direction opposite said extension whereby said opposite extension serves to protect a lead from said housing as well as providing a support for cooperation with a coil winding machine as a coil is wound about said capsule.

3. The improved structure of claim 1, wherein said housing and first and second tube member means are substantially cylindrical, said switch device comprising a reed switch encapsulated in glass.

4. The improvement of claim 1 wherein said flange includes a radial slot for receipt of a lead wire from said coil.

5. The improvement of claim 1 wherein said first and second tube member means are adhered to said housing by an adhesive.

6. The improvement of claim 1 wherein said first and second tube member means are affixed to said capsule by utilizing a shrinkable plastic material for said extension on said tube member means.

7. A structure for use in combination with an encapsulated reed switch cooperative to hold a coil in a substantially fixed position on said reed switch, comprising, in combination:

a pair of first extension members each of said first extensions connectible to opposite ends of said reed switch including a passage for receipt of one end of said housing and a flange extending at least partially about said extension member and cooperative with said coil to hold said coil on said encapsulated reed switch.

8. The improved structure of claim 7 wherein each of said first extensions is connected to second extensions extending in the opposite direction from said first extension, each of said first and second connected extensions including a passageway through said extensions for a lead from said reed switch.

* * * * *