

(12) INTERNATIONAL APPLICATION PUBLISHED UNDER THE PATENT COOPERATION TREATY (PCT)

(19) World Intellectual Property Organization
International Bureau



(43) International Publication Date
9 August 2001 (09.08.2001)

PCT

(10) International Publication Number
WO 01/56634 A1

(51) International Patent Classification⁷: **A61M 5/168**,
5/172, 25/00, 31/00, B81B 3/00, 1/00

Michael, F.; 2173 East Kempton Road, Chandler, AZ 85225 (US). **LARSON, Lary, R.**; 10132 East Daybreak Place, Gold Canyon, AZ 85219 (US). **HERUTH, Kenneth, T.**; 4904 Bruce Avenue, Edina, MN 55424 (US).

(21) International Application Number: PCT/US01/03536

(22) International Filing Date: 2 February 2001 (02.02.2001)

(74) Agents: **WALDKOETTER, Eric** et al.; Medtronic, Inc. MS 301, 7000 Central Avenue N.E., Minneapolis, MN 55432 (US).

(25) Filing Language: English

(26) Publication Language: English

(81) Designated State (*national*): DE.

(30) Priority Data:
60/179,924 3 February 2000 (03.02.2000) US

Published:
— with international search report
— before the expiration of the time limit for amending the claims and to be republished in the event of receipt of amendments

(71) Applicant: **MEDTRONIC, INC.** [US/US]; 7000 Central Avenue N.E., Minneapolis, MN 55432 (US).

(72) Inventors: **THOMPSON, David, L.**; 14171 Alder Street Northwest, Andover, MN 55304 (US). **MATTES,**

For two-letter codes and other abbreviations, refer to the "Guidance Notes on Codes and Abbreviations" appearing at the beginning of each regular issue of the PCT Gazette.

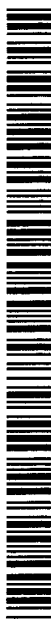

(54) Title: VARIABLE INFUSION RATE CATHETER

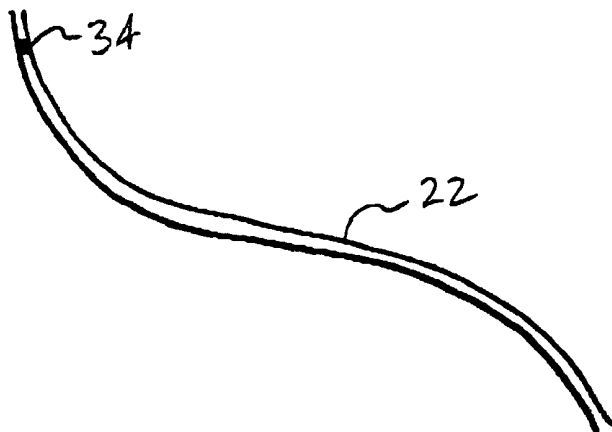

(57) Abstract: The variable infusion rate catheter (22) has a Micro Electro Mechanical System (MEMS) flow restriction (34) with a variable infusion rate. The MEMS flow restriction is fluidly coupled to the catheter to receive therapeutic substance dispensed from a therapeutic substance delivery device and restrict the therapeutic substance flow to a desired infusion rate.

WO 01/56634 A1

VARIABLE INFUSION RATE CATHETER

BACKGROUND OF THE INVENTION

5 This disclosure relates to a medical device and more particularly to a catheter used to deliver a therapeutic substance.

10 The medical device industry produces a wide variety of electronic and mechanical devices for treating patient medical conditions. Depending upon medical condition, medical devices can be surgically implanted or connected externally to the patient receiving treatment. Clinicians use medical devices alone or in combination with therapeutic substance therapies and surgery to treat patient medical conditions. For some medical conditions, medical devices provide the best, and sometimes the only, therapy to restore an individual to a more healthful condition and a fuller life. One type of medical device is a catheter used to deliver a therapeutic substance.

15 Catheters are used to deliver a therapeutic substance from a source such as a therapeutic substance deliver device to a desired infusion site. Therapeutic substance delivery devices are also known as drug pumps and drug delivery devices can be located external to a patient or implanted within the patient. An example of a therapeutic substance delivery devices is a SynchroMed® Infusion System available from Medtronic, Inc. which includes a Model 8709 InDura catheter. Catheters can be partially inserted or implanted in a patient or fully implanted with the proximal end connected to a therapeutic substance delivery device and the distal end located near the desired infusion site. Catheter delivered therapeutic substances are typically used to treat a condition that responds to a therapeutic substance delivered directly to an infusion site in the body rather than being ingested. Catheters can be employed to treat conditions such as pain, spasticity, cancer, infections, gene abnormalities, and the like.

25 Catheters are typically configured with infusion rate openings fixed when the catheter is manufactured. Some catheters have a single opening at the distal end of the catheter, so the infusion rate is essential the same as the therapeutic substance deliver

30

device infusion rate. Some catheters have more than one opening that can be configured near the catheter distal end or along the length of the catheter.

For the foregoing reasons, there is a need for a variable infusion rate catheter that permits a clinician to adjust the catheter's infusion rate before use and during use to make the catheter more versatile in treating medical conditions and have many other improvements.

SUMMARY OF THE INVENTION

The variable infusion rate catheter has a Micro Electro Mechanical System (MEMS) variable flow restriction fluidly coupled to the catheter to make the catheter more versatile and provide many other improvements. The variable infusion rate catheter permits a clinician to change the infusion rate either before the catheter is placed at an infusion site or after the catheter has been placed at an infusion site. The MEMS variable flow restriction is adjustable to vary the infusion rate from at least one catheter infusion opening. More than one MEMS variable flow restrictions can be used with a catheter to permit the catheter to have different infusion rates at different infusion openings. The catheter is coupleable to a therapeutic substance delivery device and configured to deliver therapeutic substance to a single or multiple delivery sites in a body. Many embodiments of the variable infusion rate catheter and its methods of operation are possible.

BRIEF DESCRIPTION OF THE DRAWINGS

FIG. 1 shows the environment of a variable infusion rate catheter embodiment;

FIG. 2a shows a variable infusion rate catheter embodiment;

FIG. 2b shows another variable infusion rate catheter embodiment;

FIG. 3 shows an electrical circuit schematic for a variable infusion rate catheter with

Micro Electro Mechanical System (MEMS) flow restriction embodiment;

FIG. 4 shows a block diagram of a MEMS flow restriction embodiment;

FIG. 5 shows an isometric view of a MEMS flow restriction embodiment;

FIG. 6a shows a top view of a MEMS flow restriction having multiple outlets embodiment;

FIG. 6b shows a side view of the MEMS in FIG. 4a embodiment;

FIG. 7a shows a top view of a MEMS flow restriction having a continuous flow path embodiment;

FIG. 7b shows a side view of the MEMS in FIG. 5a embodiment;

FIGS. 8a-8c show views of a stepwise actuator for a MEMS flow restriction embodiment;

5 FIG. 8d shows a Direct Current (DC) motor actuator for a MEMS flow restriction embodiment;

FIG. 8e shows a heat engine actuator for a MEMS flow restriction embodiment;

FIGS. 9a-9c show valve configurations for MEMS flow restriction embodiments; and,

FIG. 10 shows a flowchart of a method for varying a catheter infusion rate.

10

DETAILED DESCRIPTION OF THE PREFERRED EMBODIMENTS

FIG. 1 shows the environment of a variable infusion rate catheter 22 embodiment. The catheter, typically connected to a therapeutic substance delivery device 20, can be used for a wide variety of therapies such as pain, spasticity, cancer, and other medical conditions. For implantable versions of the therapeutic substance delivery device 20, 15 implantation is typically done by a clinician such as a surgeon in a sterile percutaneous or surgical procedure performed under local, regional, or general anesthesia. In some embodiments, before implanting the therapeutic substance delivery device 20, a catheter 22 can be implanted with the distal end 24 positioned at the desired therapeutic substance delivery site and the proximal end tunneled to the location where the therapeutic substance delivery device 20 is to be implanted. The implantable therapeutic substance delivery device 20 is generally implanted subcutaneously about 2.5 cm (1.0 inch) beneath the skin where there is sufficient subcutaneous tissue to support the implanted system. Once the therapeutic substance delivery device 20 is subcutaneously implanted into the patient the opening used to insert the therapeutic substance delivery device 20 is closed. When the therapeutic substance delivery device 20 is surgically implanted, the incision can be 25 sutured closed.

The therapeutic substance delivery device 20 operates to infuse a therapeutic substance 26 at a programmed rate into a patient 30. The therapeutic substance 26 is a 30 product or substance intended to have a therapeutic effect such as pharmaceutical compositions, genetic materials, biologics, and other substances. Pharmaceutical

compositions are chemical formulations intended to have a therapeutic effect such as intrathecal antispasmodics, pain medications, chemotherapeutic agents, and the like. Pharmaceutical compositions are often configured to function in an implanted environment with characteristics such as stability at body temperature to retain therapeutic qualities, concentration to reduce the frequency of replenishment, and the like. Genetic materials are substances intended to have a direct or indirect genetic therapeutic effect such as genetic vectors, genetic regulator elements, genetic structural elements, DNA, and the like. Biologics are substances that are living matter or derived from living matter intended to have a therapeutic effect such as stem cells, platelets, hormones, biologically produced chemicals, and the like. Other substances are substances intended to have a therapeutic effect yet are not easily classified such as saline solution, fluoroscopy agents, and the like.

FIGS. 2a-2b show variable infusion rate catheter embodiments, and FIG. 3 shows a schematic for a therapeutic substance delivery device 20 with a Micro Electro Mechanical System (MEMS) infusion control embodiment. In FIG. 2a, a single catheter 22 has a MEMS flow restriction 34 to adjust the infusion rate. In FIG. 2b, the catheter 22 has a first flow path 23 and a second flow path 25, and each flow path has a MEMS flow restriction, so each flow path can have an independent infusion rate.

FIG. 4 shows a MEMS flow restriction 34 block diagram embodiment, and FIG. 5 shows an isometric view of a MEMS flow restriction 34 embodiment. A MEMS flow restrictor 34 is fluidly coupled to the reservoir outlet 36 to receive therapeutic substance 26 dispensed from the reservoir 32 at the reservoir rate. The MEMS flow restriction 34 restricts the therapeutic substance 26 flow to an infusion rate. The MEMS flow restriction 34 is comprised of a substrate 37, a MEMS inlet 38, a MEMS outlet 36, a passive power source 40, electronics 42, an actuator 44, and a valve 46. The flow restriction 48 provides a structure to restrict therapeutic substance 26 flow that can be varied with a valve 46 such as a continuous path, a plurality of restriction outlets, and the like. MEMS 34 components such as the MEMS inlet 38 and MEMS outlet 36 can be assembled using glass frit bonding, electrostatic anodic bonding, and the like. MEMS 34 components that may contact the therapeutic substance 26 can be coated with a substance to improve chemical compatibility with the therapeutic substance and with body tissues such as titanium,

platinum, gold, parylene, and the like. The MEMS substrate 37 can be cut in shape appropriate for the application such as round, rectangular, square, and the like with a laser cutter or wafer scribe saws. When configured in a round shape, the MEMS 34 is particularly well suited for use in a catheter 22 or single-use reservoir outlet 36.

5 The passive power source 40 is carried on the substrate 37 and comprises an antenna coil 50 and modulation circuitry 52. The passive power source 40 is capable of supplying power upon being energized by a Radio Frequency source. In one embodiment, the passive power source is operated according to Radio Frequency Identification (RFID) principals such as described in the Microchip Technology Inc., microID™ 125 kHz RFID System Design Guide (1998), U.S. Patent No. 5,833,603 "Implantable Biosensing Transponder" by Kovacs et al., and U.S. Patent No. 5,252,962 "System Monitoring Programmable Implantable Transponder" by Urbas et al. The RF signal is transmitted by a device such as an interrogator or a clinician's programmer configured to transmit the RF signal. The RF signal can be generated at any acceptable frequency such as 125 KHz, 10 13.56 MHz, 2.4 GHz, and the like. The RF signal field varies in voltage from the very near field of about 200 V_{pp} to the far field of about 5 V_{pp}. The RF signal contacts a carrier signal at the selected frequency and a data signal modulated on this carrier signal with modulation techniques such as amplitude modulation, frequency modulation, frequency shift keying, phase modulation, phase shift keying, and the like. When the RF signal passes through the antenna coil 50, an Alternating Current (AC) voltage is generated 15 across the antenna coil 50 and the antenna coil 50 receives the data signal. In addition to the passive power source 40, the MEMS flow restriction 34 could be configured similarly to that disclosed in U.S. Patent No. 5,702,618 by Saaski and operated as described in Akiyama "Controlled Stepwise Motion In Polysilicon Microstructures" IEEE Journal of Microelectromechanical Systems, Vol. 2, No. 3 (September 1993). The MEMS flow 20 restriction 34 can also be configured as described below.

 The electronics 42 are carried on the substrate 37 and coupled to the passive power source 40. The electronics 42 include a rectifier 54, receiver circuitry 56, and control circuitry 58. The rectifier 54 rectifies the AC voltage generated across the antenna coil 50 to power the MEMS 34. The rectified power available to the MEMS 34 depends upon 25 how the passive power source 40 is configured and can range from a voltage from less

than about 2 VDC to about 10 VDC and current from less than about 5 μ A to about 50 mA. The receiver 56 is configured for the type of modulation being used to receive the data signal and produces an information signal. The control circuitry 58 converts the information signal into a control signal that is configured to operate the actuator. In some
5 embodiments, the electronics 42 can be configured with a transmitter 60 to transmit selected information from nonvolatile memory 62 through the antenna coil 50 to the interrogator. The transmitter 62 can be a shunt transistor placed across the antenna coil 50 that is operated to cause amplitude fluctuations in the interrogator's RF carrier amplitude. The backscattered signal can be used to provide information about the MEMS 34 such as
10 the MEMS 34 model number, MEMS 34 serial number, programmed infusion rate, and the like.

The actuator 44 is carried on the substrate and coupled to the electronics 42. The actuator 44 is a device that moves to operate the valve 46 in response to the control signal such as a stepwise rotor, a heat motor, a Direct Current (DC) motor, and the like. The heat
15 motor contains a material that changes shape or volume in response to heat such as a memory metal, wax, and the like. In a memory metal embodiment, the memory metal such as nitinol can be formed in the shape of a bubble that changes shape in response to heat. In some embodiments, the actuator 44 can include a mechanical coupling between the actuator and the valve such as a ratchet wheel to couple the heat motor to the valve, a
20 gear to couple the DC motor to the valve, and the like.

The valve 46 is moveably coupled to the substrate 37 to selectively engage the flow restriction 48. The valve 46 can take many different forms to adjust the flow
restriction 48 such as a shutter, a moveable plate, a rotatable restrictor, and the like. When the valve is a moveable plate or shutter, the valve can be configured in a variety of shapes
25 such as a circle, oval, triangle, and the like (FIGS. 9a-9c). The valve 46 is operated by the actuator 44 to selectively adjust the flow restriction 48 to create the infusion rate.

Many different embodiments of MEMS flow restriction 34 components are possible. FIGS. 6a-6b show an embodiment using multiple outlets that are opened,
partially opened, and closed by the actuator. In another version of this embodiment, the
30 multiple outlets are covered with a membrane. The infusion rate is programmed by the actuator 44 breaking or blowing the membrane covering selected outlets. A limitation in

using membrane as the valve is that once the membrane is opened over a selected outlet that outlet cannot be closed, so reprogramming is limited to increasing the infusion rate. FIGS. 7a-7b show an embodiment of the MEMS flow restriction 34 with a continuous flow path 62. FIGS. 8a-8c show an actuator 44 embodiment using controlled stepwise motion. The stepwise motion is created by applying a voltage across the L shaped member and the substrate causing the L shaped member to be electrostatically attracted to the substrate. When the voltage is no longer applied, the L shaped member relaxes, and the L shaped member has moved forward Δx . FIG. 8d shows a DC motor 64 that can operate bi-directionally engaging a gear 66 that rotates a rotary valve 46 to adjust the infusion rate. FIG. 8e shows a heat engine 68 engaging a ratchet wheel 70 that can rotate a rotary valve 46 such as shown in FIG. 8d to adjust the infusion rate. FIGS. 9a-9c show various shapes for shutter type valves 46. The shutters can be shaped to change the infusion rate with movement in a linear or nonlinear manner.

In an alternative embodiment, a MEMS flow restriction 34 can be placed downstream from the reservoir 32 on the catheter 22 whether or not the reservoir 32 has a flow restriction 48. In another embodiment, two or more MEMS flow restrictions 34 can be placed downstream from the reservoir 32 on one or more catheters 22 whether or not the reservoir 32 has a flow restriction. When the MEMS flow restriction 34 is placed serially on a catheter 22, different infusion outlets can have different infusion rates. When more than one MEMS flow restriction 34 is placed on two or more branches of a catheter 22, the different catheter branches can have different infusion rates.

FIG. 10 shows a method for operating the MEMS flow restriction 34. The MEMS flow restriction 34 operates according to the following method. A passive power supply is energizing 74 with a radio frequency signal. The energized passive power supply powers 76 the electronics. The powered electronics receive 78 an information signal modulated on the radio frequency signal. The information signal contains at least one instruction for the MEMS flow restriction such as change the infusion rate, identify the MEMS flow restriction by model and serial number, and the like. The electronics generate 80 a control signal that is response to the information signal. The control signal is configured to drive the actuator used in the MEMS flow control embodiment. The actuator operates 82 in response to the control signal. The motion of the actuator is used to adjust 84 the valve to

adjust the flow restriction to an infusion rate. In some embodiments, the method can also include transmitting a status signal with the electronics such as the currently programmed infusion rate.

FIG. 10 shows a method for operating the MEMS flow restriction used with a variable infusion rate catheter. The MEMS flow restriction operates according to the following method. A MEMS flow restriction 34 is positioned 73 in the catheter. A passive power supply is energizing 74 with a radio frequency signal. The energized passive power supply powers 76 the electronics. The powered electronics receive 78 an information signal modulated on the radio frequency signal. The information signal contains at least one instruction for the MEMS flow restriction such as change the infusion rate, identify the MEMS flow restriction by model and serial number, and the like. The electronics generate 80 a control signal that is response to the information signal. The control signal is configured to drive the actuator used in the MEMS flow control embodiment. The actuator operates 82 in response to the control signal. The motion of the actuator is used to adjust 84 the valve to adjust the flow restriction to an infusion rate. In some embodiments, the method can also include transmitting a status signal with the electronics such as the currently programmed infusion rate.

The catheter with a Micro Electro Mechanical System (MEMS) variable infusion rate comprises a catheter, and a MEMS variable flow restriction. The catheter is coupleable to a therapeutic substance delivery device. The catheter configured to deliver therapeutic substance to one or more delivery sites in a body. The MEMS variable flow restriction is fluidly coupled to the catheter. The MEMS variable flow restriction is adjustable to vary the infusion rate from at least one catheter infusion opening.

The catheter 22 can be percutaneously inserted into a patient, and the catheter 22 can be programmed after implantation. The catheter 22 serves as a means for therapeutic substance 26 delivery to a delivery site. In one embodiment, the catheter 22 has at least a first flow path 23 and a second flow path 25. The first flow path 23 and the second flow path 25 each have a MEMS variable flow restriction 34 capable of providing a first infusion rate and a second infusion rate.

Thus, embodiments of the variable infusion rate catheter are disclosed to increase versatility, increase flexibility, and provide many other improvements. One skilled in the

art will appreciate that the present invention can be practiced with embodiments other than those disclosed. The disclosed embodiments are presented for purposes of illustration and not limitation, and the present invention is limited only by the claims that follow.

What is claimed is:

1. A variable infusion rate catheter, comprising:
5 a catheter coupleable to a therapeutic substance delivery device, the catheter configured to deliver therapeutic substance to a delivery site in a body; and, a Micro Electro Mechanical System (MEMS) variable flow restriction fluidly coupled to the catheter, the MEMS variable flow restriction adjustable to vary the infusion rate from at least one catheter infusion opening.
- 10 2. The catheter as in claim 1 wherein the catheter is configured to be percutaneously inserted into a patient.
3. The catheter as in claim 1 wherein the catheter is configured to be programmed after implantation.
4. The variable infusion rate catheter as in claim 1 wherein the MEMS variable flow
15 restriction further comprises,
a substrate having a therapeutic substance flow path with a therapeutic substance input, a flow restriction, and a therapeutic substance output;
a passive power source carried on the substrate, the passive power source
20 capable of supplying power upon being energized by a radio frequency source;
electronics carried on the substrate and coupled to the passive power supply, the electronics generating a control signal;.
an actuator carried on the substrate and coupled to the control electronics,
25 the actuator moving in response to the control signal; and,
a valve moveably coupled to the substrate to selectively engage the flow restriction, the valve operated by the actuator to selectively adjust the flow restriction to for an infusion rate.
5. The catheter as in claim 1 wherein the catheter has a proximal end and a distal end,
30 the distal end having at least a first flow path and a second flow path, the first flow

path and the second flow path each having a MEMS variable flow restriction capable of providing a first infusion rate and a second infusion rate.

6. A variable infusion rate catheter, comprising:
means for therapeutic substance delivery to deliver therapeutic substance to a
5 delivery site; and,
means for variable flow restriction fluidly coupled to the means for therapeutic
substance delivery, the means for variable flow restriction including a
Micro Electro Mechanical System (MEMS) variable flow restriction
adjustable to vary the infusion rate from at least one catheter infusion
10 opening.
7. A method for varying a catheter infusion rate, comprising:
positioning a MEMS variable flow control on a catheter;
energizing a passive power supply with a radio frequency signal;
powering electronics with the passive power supply;
15 receiving an information signal modulated on the radio frequency signal with the
electronics;
generating a control signal that is responsive to the information signal with the
electronics;
operating an actuator in response to the control signal; and,
20 moving a valve with the actuator to adjust the flow restriction for an infusion rate.
8. The method as in claim 16, further comprising,
supplying the catheter with therapeutic substance; and,
infusing therapeutic substance from the catheter at the programmed infusion rate.
9. A Micro Electro Mechanical System (MEMS) variable flow restriction for a
25 catheter, comprising:
a substrate having a drug flow path with drug input, a flow restriction, and a drug
output;
a passive power source carried on the substrate, the passive power source capable
of supplying power upon being energized by a radio frequency source;
30 electronics carried on the substrate and coupled to the passive power supply, the
electronics generating a control signal;.

an actuator carried on the substrate and coupled to the electronics, the actuator moving in response to the control signal; and, a valve moveably coupled to the substrate to selectively engage the flow restriction, the valve operated by the actuator to selectively adjust the flow restriction to modulate the flow through the drug flow path.

- 5
10. The MEMS flow restrictor as in claim 9 wherein the control electronics include nonvolatile memory.
11. The MEMS flow restrictor as in claim 9 wherein the actuator is a D.C. motor coupled to the valve with a gear.
- 10 12. The MEMS flow restrictor as in claim 9 wherein the actuator is a heat motor coupled to the valve with a ratchet wheel.
13. The MEMS flow restrictor as in claim 9 wherein the actuator is a stepwise rotor coupled to the valve.
14. The MEMS flow restrictor as in claim 9 wherein the flow restriction is a
- 15 continuous path.
15. The MEMS flow restrictor as in claim 9 wherein the flow restriction is a plurality of restriction outlets selectable by the valve.
16. A Micro Electro Mechanical System (MEMS) flow restriction for a catheter, comprising:
- 20 means for therapeutic substance flow having a therapeutic substance input, a flow restriction, and a therapeutic substance output;
- means for power carried on the means for therapeutic substance flow, the means for power capable of supplying power upon being energized by a radio frequency source;
- 25 means for programming to store flow restriction program;
- means for electronics control to receive the flow restriction program and generate a control signal;
- means for actuation to create motion in response to the control signal; and,
- means for valving to adjust therapeutic substance flow through the flow restriction
- 30 moveably coupled to the substrate to selectively engage the flow

restriction, the shutter operated by the actuator to selectively adjust the flow restriction to modulate the flow through the drug flow path.

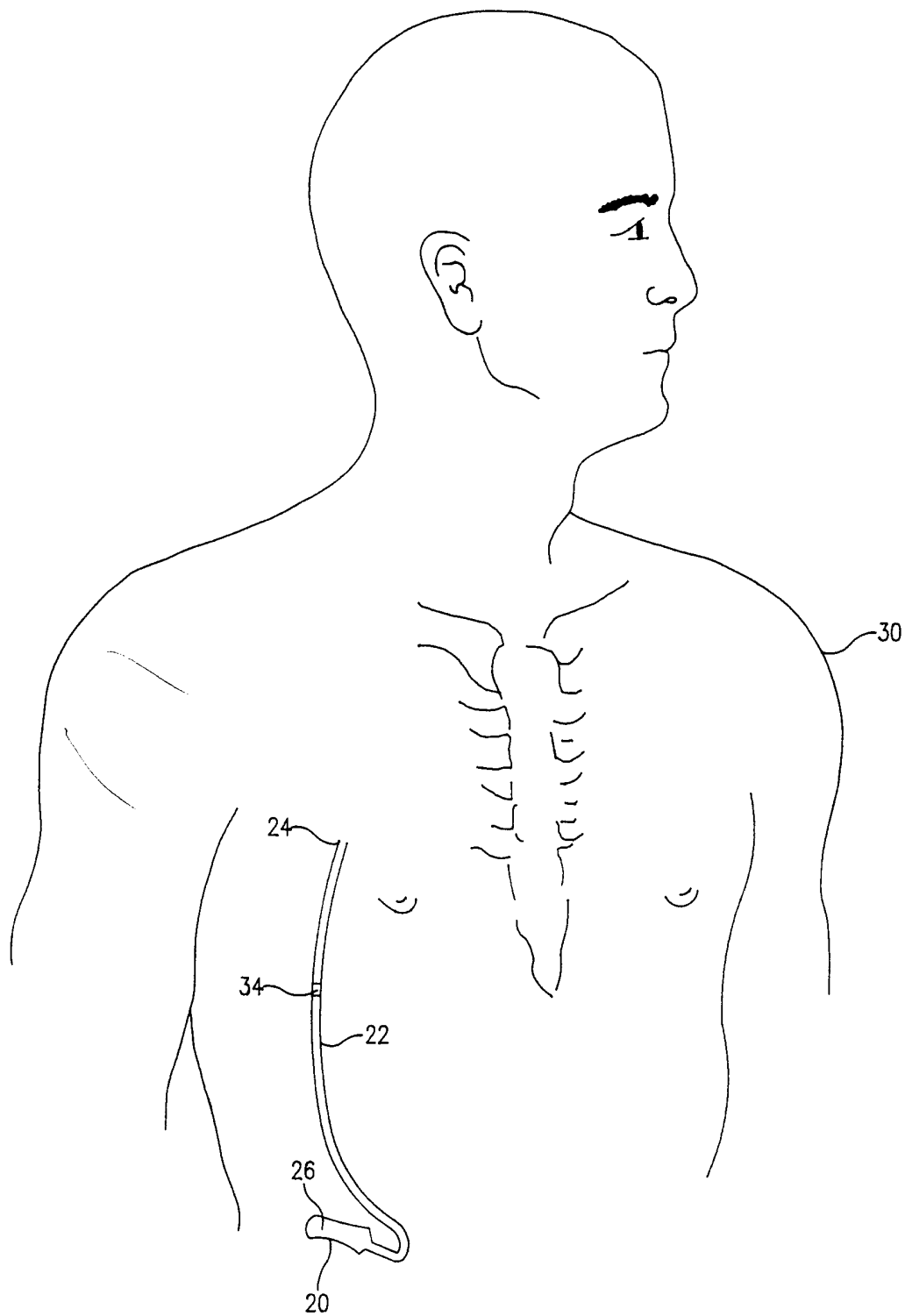

FIG. 1

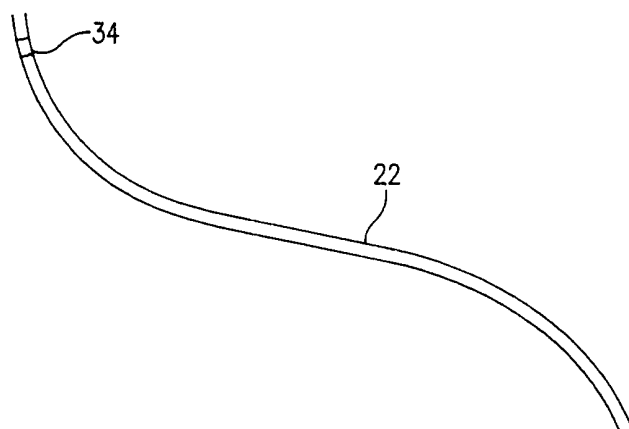

FIG. 2a

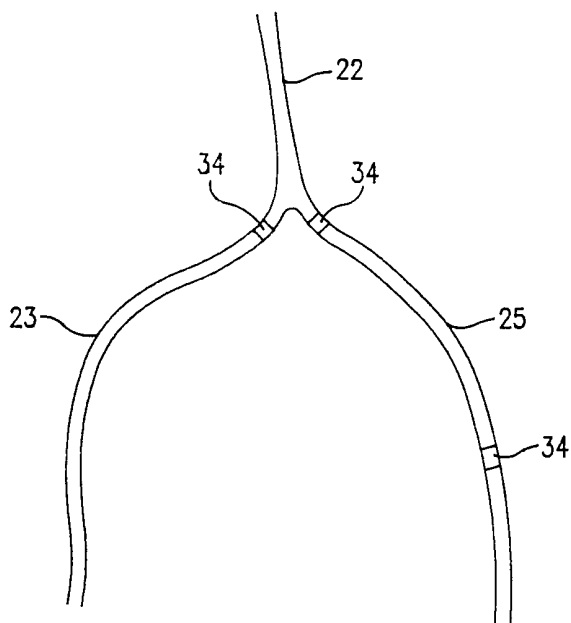

FIG. 2b

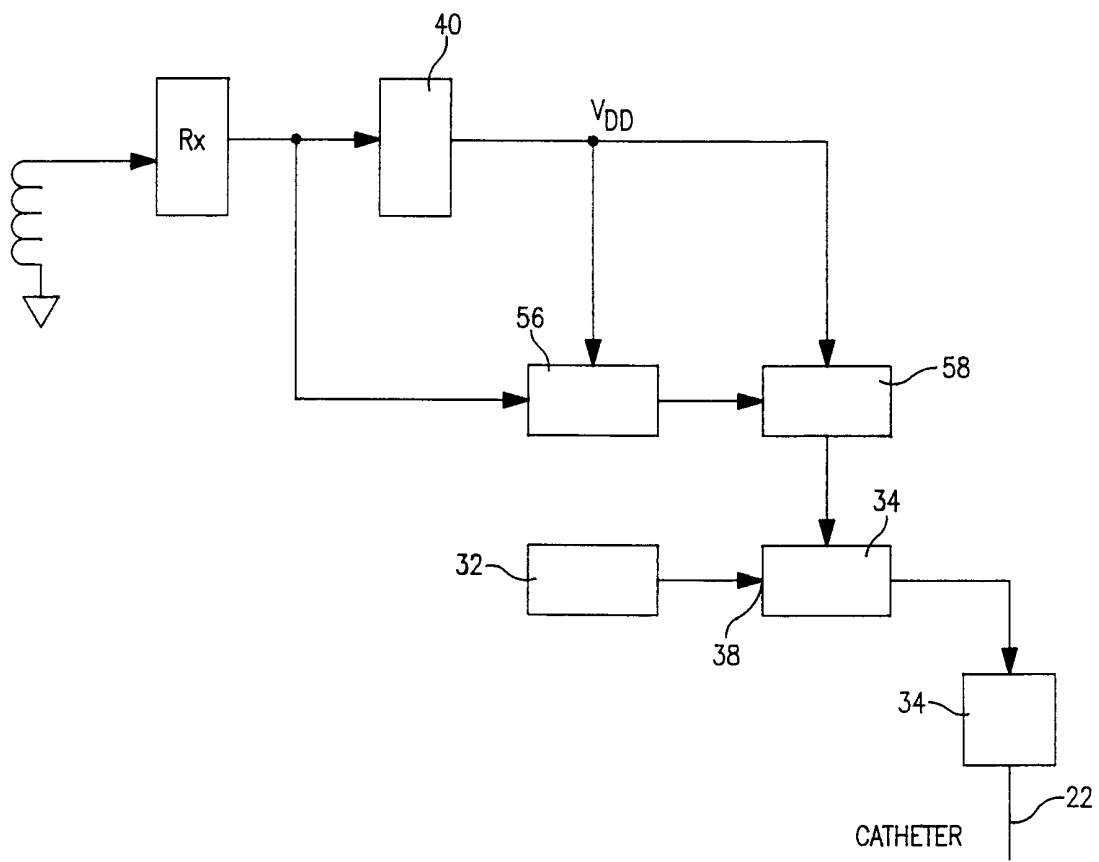

FIG. 3

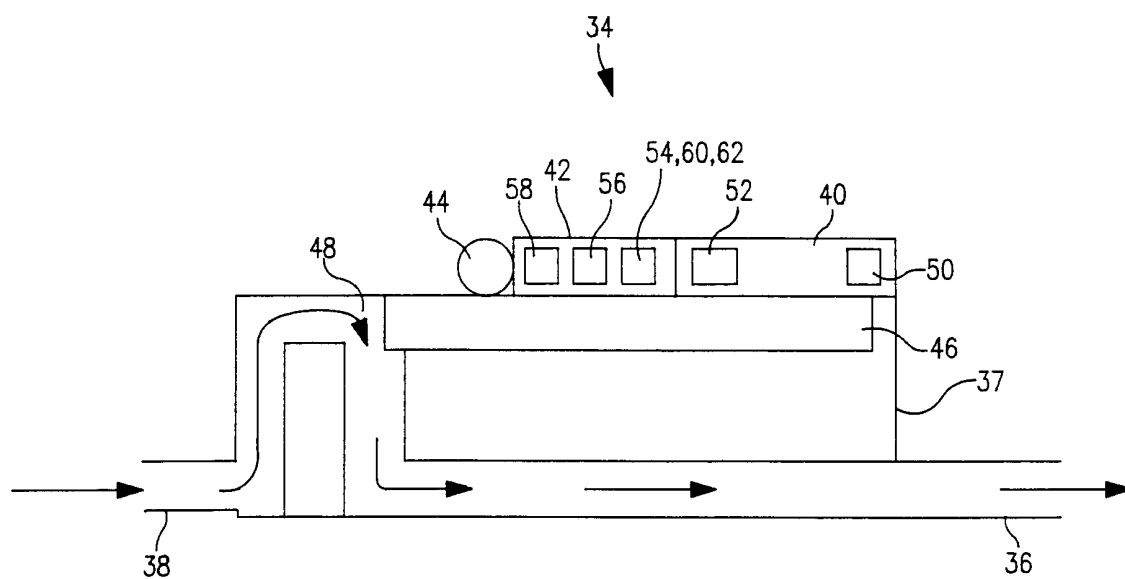

FIG. 4

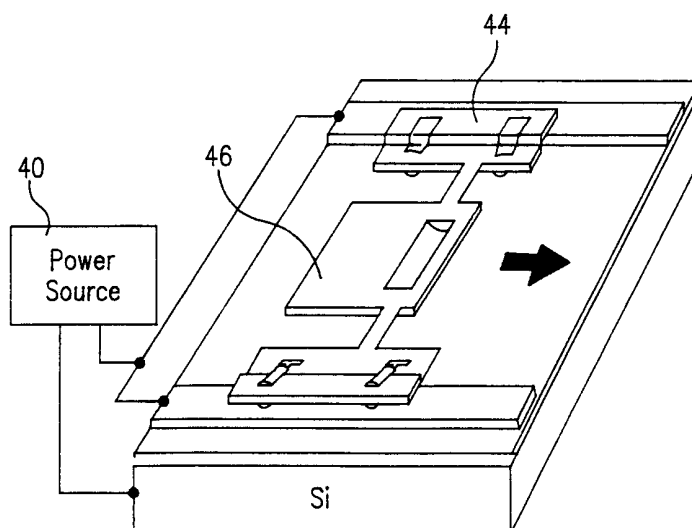

FIG. 5

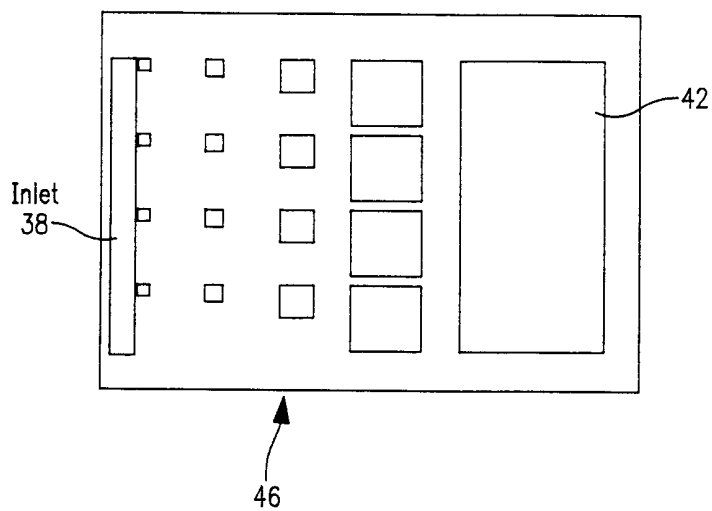

FIG. 6a

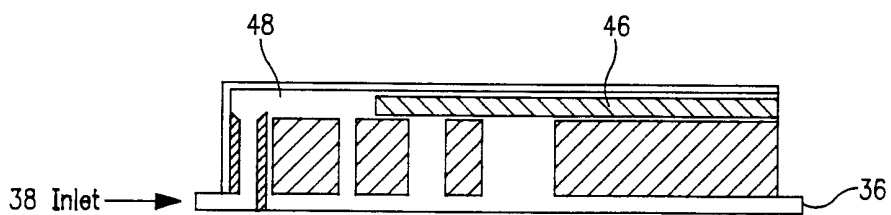

FIG. 6b

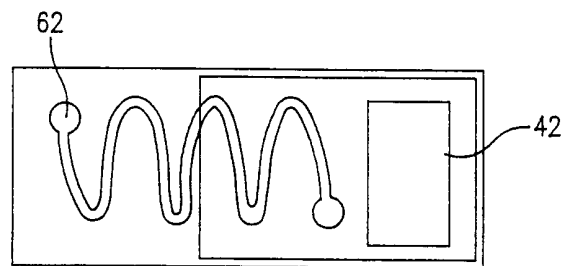

FIG. 7b

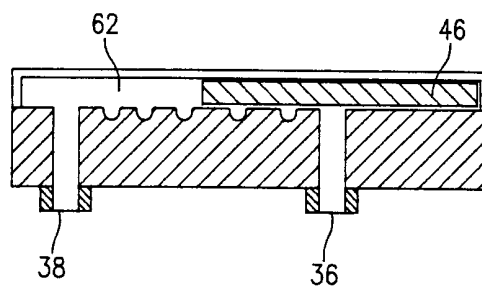

FIG. 7b

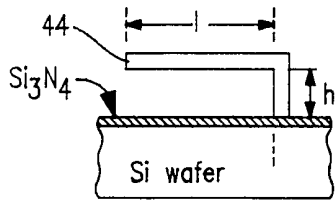

FIG. 8a

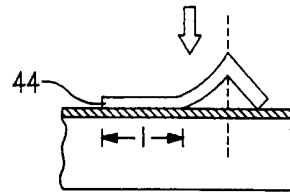

FIG. 8b

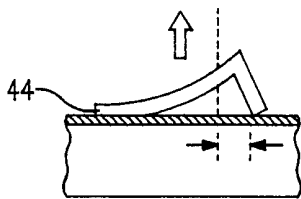

FIG. 8c

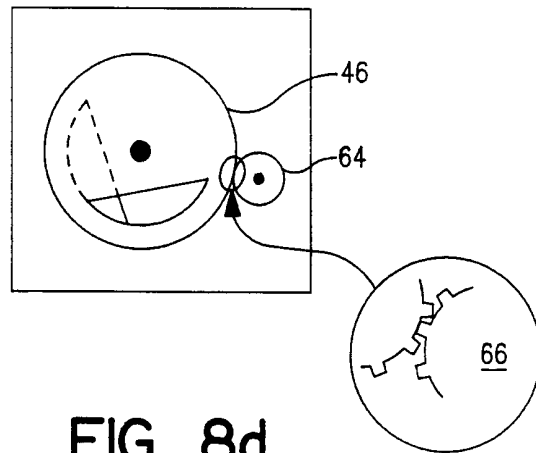

FIG. 8d

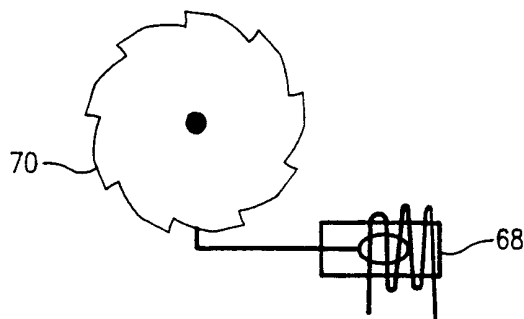

FIG. 8e

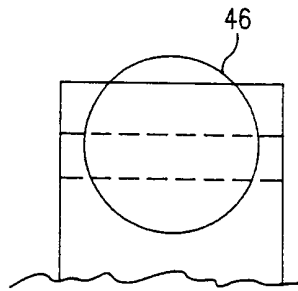

FIG. 9b

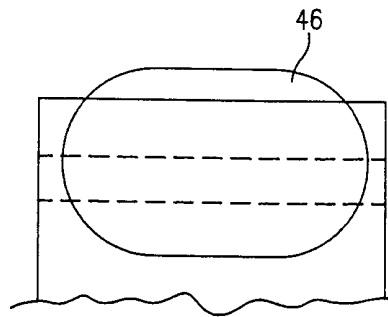

FIG. 9b

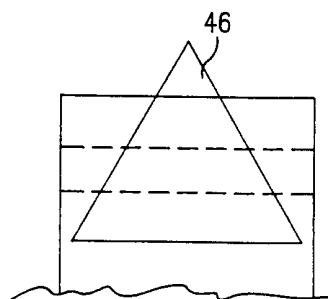

FIG. 9c

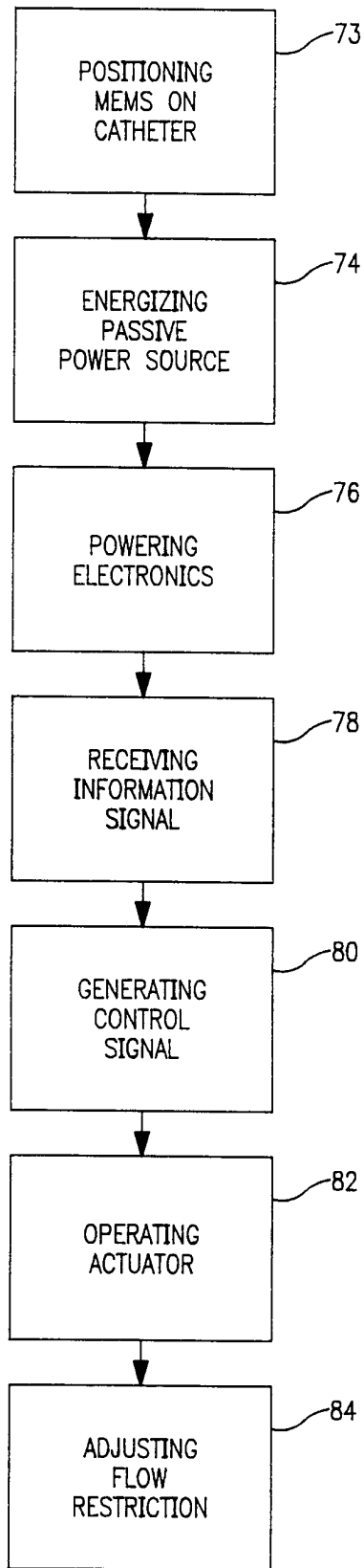

FIG. 10

INTERNATIONAL SEARCH REPORT

International Application No

PCT/US 01/03536

A. CLASSIFICATION OF SUBJECT MATTER IPC 7 A61M5/168 A61M5/172 A61M25/00 A61M31/00 B81B3/00 B81B1/00		
According to International Patent Classification (IPC) or to both national classification and IPC		
B. FIELDS SEARCHED Minimum documentation searched (classification system followed by classification symbols) IPC 7 A61M B81B		
Documentation searched other than minimum documentation to the extent that such documents are included in the fields searched		
Electronic data base consulted during the international search (name of data base and, where practical, search terms used) WPI Data, EPO-Internal, PAJ		
C. DOCUMENTS CONSIDERED TO BE RELEVANT		
Category °	Citation of document, with indication, where appropriate, of the relevant passages	Relevant to claim No.
X	EP 0 564 321 A (CELSA L G SA) 6 October 1993 (1993-10-06) the whole document	1-3,5,6
A	---	4,9, 14-16
X	EP 0 300 552 A (CORDIS EUROP) 25 January 1989 (1989-01-25) page 3, column 3, line 52 -column 4, line 52; figures 1-3 page 7, column 11, line 55 -column 12, line 55	9,10,14, 16 1-4,6
A	---	
A	US 4 871 351 A (FEINGOLD VLADIMIR) 3 October 1989 (1989-10-03) column 3, line 54 -column 5, line 58; figures 1,2,4,5	1-4,6

	-/--	
<input checked="" type="checkbox"/> Further documents are listed in the continuation of box C. <input checked="" type="checkbox"/> Patent family members are listed in annex.		
° Special categories of cited documents :		
A document defining the general state of the art which is not considered to be of particular relevance *E* earlier document but published on or after the international filing date *L* document which may throw doubts on priority claim(s) or which is cited to establish the publication date of another citation or other special reason (as specified) *O* document referring to an oral disclosure, use, exhibition or other means *P* document published prior to the international filing date but later than the priority date claimed		
T later document published after the international filing date or priority date and not in conflict with the application but cited to understand the principle or theory underlying the invention *X* document of particular relevance; the claimed invention cannot be considered novel or cannot be considered to involve an inventive step when the document is taken alone *Y* document of particular relevance; the claimed invention cannot be considered to involve an inventive step when the document is combined with one or more other such documents, such combination being obvious to a person skilled in the art. *&* document member of the same patent family		
Date of the actual completion of the international search	Date of mailing of the international search report	
7 June 2001	15/06/2001	
Name and mailing address of the ISA	Authorized officer	
European Patent Office, P.B. 5818 Patentlaan 2 NL - 2280 HV Rijswijk Tel. (+31-70) 340-2040, Tx. 31 651 epo nl, Fax: (+31-70) 340-3016	Jameson, P	

INTERNATIONAL SEARCH REPORT

International Application No
PCT/US 01/03536

C.(Continuation) DOCUMENTS CONSIDERED TO BE RELEVANT

Category °	Citation of document, with indication, where appropriate, of the relevant passages	Relevant to claim No.
A	EP 0 344 895 A (SHILEY INFUSAID INC) 6 December 1989 (1989-12-06) the whole document -----	1-3,6
A	PATENT ABSTRACTS OF JAPAN vol. 017, no. 670 (C-1139), 9 December 1993 (1993-12-09) & JP 05 220222 A (OLYMPUS OPTICAL CO LTD), 31 August 1993 (1993-08-31) abstract -----	1-3,6
A	US 5 702 618 A (SAASKI ELRIC W ET AL) 30 December 1997 (1997-12-30) cited in the application abstract; figure 16 -----	1,9,16
A	WO 98 23869 A (KLUGE STEFAN ;FRAUNHOFER GES FORSCHUNG (DE)) 4 June 1998 (1998-06-04) abstract; figure 5 -----	1,9,16
A	EP 0 892 419 A (TRW INC) 20 January 1999 (1999-01-20) abstract -----	1,9,16

INTERNATIONAL SEARCH REPORT

Information on patent family members

International Application No

PCT/US 01/03536

Patent document cited in search report	Publication date	Patent family member(s)	Publication date
EP 0564321 A	06-10-1993	FR 2689403 A	08-10-1993
		DE 69306292 D	16-01-1997
		DE 69306292 T	03-04-1997

EP 0300552 A	25-01-1989	NL 8701644 A	01-02-1989
		JP 1086978 A	31-03-1989

US 4871351 A	03-10-1989	CA 1254091 A	16-05-1989
		EP 0183351 A	04-06-1986
		JP 61222457 A	02-10-1986

EP 0344895 A	06-12-1989	US 4931050 A	05-06-1990
		AT 77963 T	15-07-1992
		AU 618999 B	16-01-1992
		AU 3271389 A	19-10-1989
		CA 1308324 A	06-10-1992
		DE 68902014 D	13-08-1992
		DE 68902014 T	18-02-1993
		DK 174789 A	14-10-1989
		ES 2033094 T	01-03-1993
		GR 3005364 T	24-05-1993
		JP 1889273 C	07-12-1994
		JP 2011162 A	16-01-1990
		JP 6013050 B	23-02-1994

JP 05220222 A	31-08-1993	NONE	

US 5702618 A	30-12-1997	DE 69415549 D	04-02-1999
		DE 69415549 T	19-08-1999
		DE 69415683 D	11-02-1999
		DE 69415683 T	09-09-1999
		EP 0722540 A	24-07-1996
		EP 0722541 A	24-07-1996
		EP 0733169 A	25-09-1996
		WO 9509987 A	13-04-1995
		WO 9509988 A	13-04-1995
		WO 9509989 A	13-04-1995
		US 5660728 A	26-08-1997
		US 5585011 A	17-12-1996
		US 5697153 A	16-12-1997
		US 5617632 A	08-04-1997
US 5705070 A	06-01-1998		
US 5839467 A	24-11-1998		

WO 9823869 A	04-06-1998	DE 19648730 A	20-08-1998
		DE 19703415 A	05-11-1998
		DE 19735156 C	29-04-1999
		DE 59703239 D	03-05-2001
		WO 9823868 A	04-06-1998
		EP 0914563 A	12-05-1999
		EP 0914564 A	12-05-1999
		JP 2000507681 T	20-06-2000
		JP 2000507682 T	20-06-2000
		US 6131879 A	17-10-2000
US 6142444 A	07-11-2000		

EP 0892419 A	20-01-1999	JP 11144596 A	28-05-1999
