



(12) **EUROPEAN PATENT APPLICATION**

(43) Date of publication:
12.11.2008 Bulletin 2008/46

(51) Int Cl.:
D06F 58/20 (2006.01) **D06F 58/24** (2006.01)
D06F 73/02 (2006.01)

(21) Application number: **07108016.2**

(22) Date of filing: **11.05.2007**

(84) Designated Contracting States:
AT BE BG CH CY CZ DE DK EE ES FI FR GB GR HU IE IS IT LI LT LU LV MC MT NL PL PT RO SE SI SK TR
 Designated Extension States:
AL BA HR MK RS

(71) Applicant: **Electrolux Home Products Corporation N.V.**
1930 Zaventem (BE)

(72) Inventors:
 • **SARTOR, Luciano**
31015, CONEGLIANO (Treviso) (IT)
 • **NOVIELLO, Flavio**
33081, AVIANO (PN) (IT)

(74) Representative: **Gonella, Mario**
PROPRIA S.r.l.
P.O. Box 365
Via della Colonna, 35
33170 Pordenone (IT)

(54) **Improved laundry dryer with refreshment operation**

(57) Household drying machine comprising a rotating drum, an air circulation duct across said drum, a moisture condenser for the drying air, a tray (12) for the collection of the condensed moisture, hydraulic means able of drawing the water contained in said tray, and of conveying it into diffusion means (22), even at a steam state, or as a spray, directly into said drum, or into said air circulation duct, wherein said hydraulic means comprise an hydraulic pipe (17) going out of said tray and eventually provided with a respective pump (13), and which branch-

es out (19), through a selectively controllable valve (18), into a secondary tank (16) connected to a channel (23) and to said diffusion or steaming means (22); said valve (18) comprises a filter (43) able of filtering the liquid flow crossing it.

Said filter (43) can be removed and extracted from the valve body (21); when said filter is introduced in said valve (18), it lets the moisture to pass, and when said filter is extracted from said valve (18), the inlet access to said valve (18) remains closed.

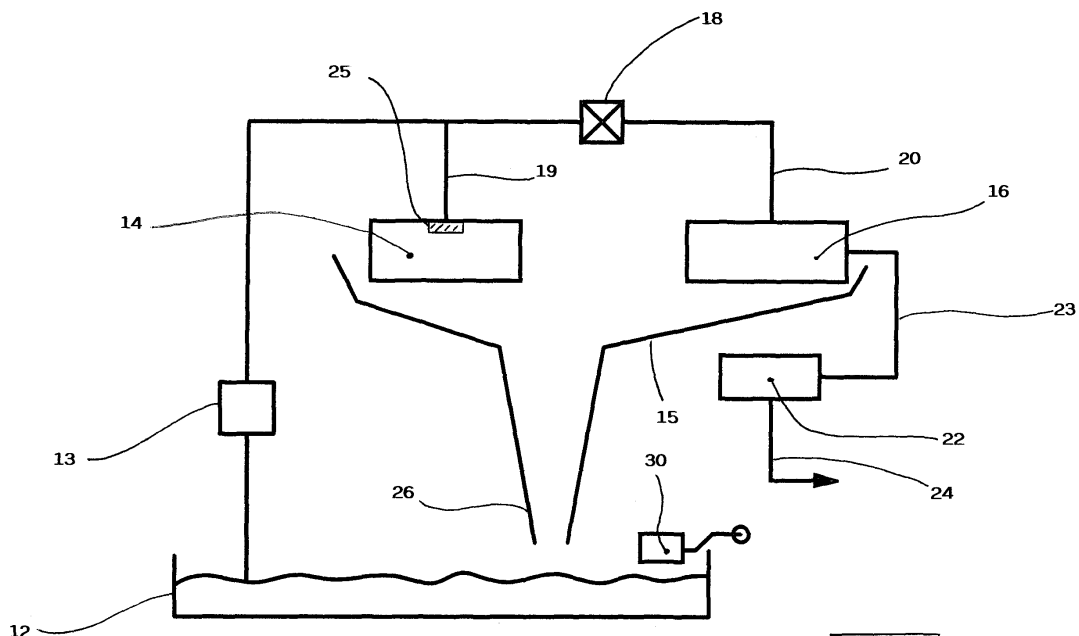

FIG. 1

Description

[0001] The invention refers to an improved type of laundry drying machine, preferably for domestic use, able of implementing refreshing and anti-wrinkling treatment for the laundry load.

[0002] Drying machines are known, which are able of producing a kind of gaseous diffusion of liquid substances and to convey said substances into a drum containing laundry, with the purpose of carrying out a refreshing or anti-wrinkling treatment.

Often the substance used for the treatment is simply steam.

[0003] Moreover when the drying machine is of the condensation type, the condensed moisture generated by said drying and condensation process is used to transform it again into a steam flow, or simply into a diffusion of atomized moisture using ultra-sound techniques, to be diffused through said laundry load to obtain the wanted effect of refreshing and anti-wrinkling.

[0004] Such machines are in a detailed way described in the European Pat. Application n. 06 118 596.3, and in the documents therein cited, and mainly in DE102 60 151 A1, to which for brevity it is here referred.

[0005] In said documents it is shown that the moisture, which is condensed during the drying process, is again collected into a suitable collection tray, wherefrom it is again taken to be transformed into steam.

[0006] However it may happen that a part of the lint and of further material which is left during the drying process, inside the drum directly into the drying air-flow going out of the drum, are not intercepted by the specific air filter, which is generally placed just at the drum exit opening; in such a case, and mainly if said filter is a little clogged, said lint remain inside the drying air-flow, wherefrom they are obviously dragged into the condenser.

[0007] Here the moisture condensing effect easily causes also the consequent effect that such moisture, during and after the relevant condensation process, drags with it also some of such lint directly into the collecting tray of the condensed moisture.

[0008] If then, as described in the cited patents, said condensed moisture is taken to be transformed into steam to be conveyed into the drum, or to be diffused or sprayed by atomization, it happens that, after a certain operation period the lint therein contained are being assembled and grouped with each other, so causing the clogging or plugging of the nozzles or of the pumps treating said moisture, fully or partially endangering the refreshing or anti-wrinkling performances.

[0009] Not to speak of the undesired effect of re-introducing the same lint, just left away from the laundry load, again into the drying air-flow.

[0010] From US 2005/0278983 it is divulged a laundry drying machine apt of producing a steam flow into the drum or into the containers wherein the laundry load is contained.

[0011] The water which is needed, is supplied by a

standard container, e.g. a bottle, and is soon properly filtered by a "filter vent" whose purpose is to intercept out of that water the there included the residual material possible therein included.

[0012] Said procedure however does not solve the above described problem with ref. to drying machines with rotating drum, both as that solution does not regard the condenser drying machines wherein the condensed moisture is re-used to produce steam, and as said vent filter is intended to separate the water flow from the air-flow, mixed to it.

[0013] The aim of the present invention is therefore to solve the noted problem and thus providing a laundry condenser drying machine allowing the user to implement a refreshing and anti-wrinkling treatment on the laundry load, consisting, without activating a drying cycle, in the production of an over-heated steam flow, which is being mixed to an air flow which is made to circulate in the same drying-air conduit, and to let said air-flow to circulate, mixed with said over-heated steam, across the rotating drum with the laundry load, without suffering any risk that the nozzles injecting out said over-heated steam be obstructed due to the lint accumulation, and without introducing again into circulation the same lint into the drying air conduit.

[0014] Advantages, objects and features of the invention will be set forth in the following description of a condenser laundry drying machine, wherein said over-heated steam is generated by a proper boiler, and is supplied by the moisture condensed in suitable trays, which is being pumped into a conduit conveying it towards said boiler; into said conduit a suitable removable filter is inserted, able of stopping all lint and foreign material out of the water-flow going into said boiler, so as to assure the water there arrived be properly clean and filtered.

[0015] The accompanying drawings, which are included to provide a further understanding of the invention and are incorporated in and constitute a part of this specification, illustrate a possible embodiment of the invention and together with the description serve to explain the principles of the invention.

[0016] In the drawings:

Figure 1 shows a schematic partial representation of the composition and of the connections of the hydraulic circuit of a laundry treatment machine according to the invention,

Figure 2 shows a perspective view of the valve 18, partly in transparency, of a laundry treating machine as per figure 1,

Figure 3 shows, in a perspective exploded view, the valve of fig. 2

Fig. 4 shows a perspective view of the valve of fig. 2 completely closed and mounted in the final arrangement,

Figures 5 and 6 show respective schematic section views of the valve according to the invention, in two respective different working status.

[0017] With ref to fig. 1, showing the schematic of the hydraulic circuit of a machine according to a prior art, and specifically of the machine described in the cited European Application n. 06 118 596.3, a drying machine according to the prior art comprises a rotating drum, not shown, containing the drying laundry load, and which is crossed by an heated air flow; the moisture extracted from the laundry load during the drying process is being condensed by a proper condenser, and is collected by a collecting tray 12.

[0018] A pump 13 and a pipe 17 convey the condensate from the tray 12 to a main tank 14, which is removably associated to the machine and preferably placed in an upper region of the cabinet 2, so as to be easily extracted by the user.

[0019] A secondary tank 16 is provided to be in fluid communication with the condensate collection tray 12 by means of the pipe 17.

[0020] Valve means 18 control the condensate flows towards the main tank 14 and the secondary tank 16.

[0021] As it will be better understood later on, a specific embodiment and function of said valve means 18 will be the subject of the instant invention.

[0022] Pipe 17 branches in a plurality of conduits 19, 20 each of the reaching the respective tank 14, 16.

[0023] Secondary tank 16 is also hydraulically connected with a pipe 23 to an inlet opening steamgenerator 22 of know type, so that the liquor contained in tank 16 can be evaporated.

[0024] Steam produced by the generator 22 flows through a pipe 24 into the drum, or alternatively into the drying air conduit, not shown, for treating laundry.

[0025] When valve means 18 are in an open position, condensate liquor available in the tray 12 during or after a laundry drying operation is pumped by the pump 13 in the pipe 17 and divided between the principal tank 14 and the secondary tank 16. In this way a portion of the total amount of liquid extracted from laundry is saved in the secondary tank 16 and made available to be reused for a subsequent steam treatment. When valve means 18 are in a closed position all the amount of condensate liquor pumped from the tray 12 is flowed into the principal tank 14 though a opening 25 that is placed at the pipe 19 outlet when the machine is in use. Said opening 25 serves also as overflow opening allowing the condensate.

[0026] According to the invention, said valve 18 is selectively controllable in its operation, not only in the sense that it may be opened or closed by an external command, but also in the sense that it contains a type of filter, which will be better described later on, whose introduction in the valve body determines the opening of the same valve, and inversely whose disengagement from the valve body determines its closing.

[0027] With ref. to the figures from 2 to 6, said valve 18 is substantially shaped as an outer cylindrical, internally hollow body, 21; to one of its ends said pipe 17 is connected, into which the condensate, coming from the

tray 12, is flowing.

[0028] On a side portion of said hollow body 21 an opening 40 is made, which branches out into the conduit 20 bound to said secondary tank 16.

[0029] Inside said hollow body 21 the actual filtering means 43 is lodged, which is made of a cylindrical element working as a support and a frame for a filtering septum 44 with very close mesh nets.

[0030] The working of said filter/valve 10 is as follows: when said filtering element 43 is being introduced into said hollow body 21, the condensed water coming from the pipe 17 enters said same hollow body and the filtering element 43, which is closed on the opposite end.

[0031] From the inside of said filtering element the condensed water, which may also be mixed with lint and foreign materials, filters trough the filtering septum 44, and gets out, flowing into the ring shaped inter-space between said septum and the inner surface of said hollow body.

[0032] From said gap the condensed water, then filtered, gets into said opening 40 and then, through said pipe 20, into said secondary tank 16.

[0033] The filtering element and its operation have been just described; in the following the valve 18 and its operation will be in detail explained.

[0034] With ref. to figures 6 and 7, said valve comprises said outer and hollow body 21, and is internally provided with an annular relief 45, which is coaxial and internally opened with an opening 46.

[0035] To its turn said filtering element 43 is provided to its end, turned to said pipe 17, with a first extension 47 apt of crossing said opening 46 and to contact, by pressure, an essentially flat and closing member 48, placed between the affluent mouth 17-A of said pipe 17 and said annular relief 45.

[0036] Advantageously said closing member 48 is provided towards said filtering element 43 with a corresponding and substantially coaxial and aligned second extension 48-A apt to engage said first extension 47.

[0037] The reciprocal sizes of said opening 46, of said annular relief 45 and of said closing member 48 are such that said closing member 48 is apt of abut up on said annular relief 45, and in this position said opening 46 is being fully closed.

[0038] A preferably spiral spring 50 is interposed between the inner end side of said hollow body 21, towards said pipe 17, and the side 48-B, in front of it, of said closing member 48; said spring works on compression, and is preferably pre-loaded.

[0039] The operation of said device is as follows:

- when the filtering element has to be extracted, it will be enough to disengage it from said outer body 21 according to known modes, for instance to reciprocally threaded means 51, 52, properly placed between the inner side of said outer body 21 and a respective portion, turned outbound, of said filtering element 43.-

- After having disengaged and extracted the filtering element 43 (Fig. 6), the pressure of said first extension 47 against said second extension 48-B of said closing member 48 fails, said pressure keeping said closing member 48 away from said annular relief 45 (fig. 5);
- As said pressure fails, said closing member 48, due to the contrary action of said spring 50, is being moved going into contact with said relief 45, pushing against it, what causes the closure of said opening 46.

[0040] So said valve, generally identified as 18, is being automatically closed by the simple extraction of the filtering element 43 out of said outer body 21 (Fig. 6).

[0041] If on the contrary said filtering element is being introduced, the just described operations are obviously reversed (fig. 5), resulting in the opening of said valve, and the condensed moisture is:

- first of all filtered,
- and the made to flow into said conduit 20 to be let into said secondary tank 16.

[0042] It will be now clear to the man skilled in the art a further advantage of the invention: in the facts not only the sought result of filtering the condensed moisture directed to the secondary tank 16 is achieved, what is the main purpose of the invention, but a further useful result is obtained, consisting in the fact that, when one wishes to remove the filtering septum itself to carry out a normal cleaning or maintenance operation, said simple operation of filter extraction automatically blocks the condensed moisture inflow both into the secondary tank 16, what is the main goal, but also prevents any moisture leakage outside of the machine across the same opening from where the filtering septum itself is extracted.

[0043] With obvious and well imaginable drawbacks.

[0044] With ref. to fig. 3, a further improvement consists in the fact that said valve 18 is positioned in such a way that the filtering element 43 be directly accessible from the front machine, and that it can be extracted from, or engaged into said outer body 21, through the simple rotation of a control element, as a rotating knob 54, placed outside the filtering element 43 itself.

Claims

1. Household drying machine comprising:

- a rotating drum for the containment and the drying of a laundry load,
- an air circulation duct able of circulating a drying air flow across said drum,
- a moisture condenser (1) for the drying air, apt of intercepting the air-flow out of said drum,
- a tray (12) for the collection of the condensed

moisture from said condenser (1),

- hydraulic means able of drawing at least a part of the water contained in said tray, and of conveying it into diffusion means (22), even at a steam state, or as a spray, directly into said drum, or into said air circulation duct,

- wherein said hydraulic means comprise an hydraulic pipe (17) going out of said tray (12) and eventually provided with a respective pump (13), able of transferring the water from said tray into said hydraulic pipe,

- which branches out (19) directly into a main tank (14) and, through a selectively controllable valve (18), into a secondary tank (16) which is connected to a channel (23) and to said diffusion or steaming means (22),

- **characterized in that** said selectively controllable valve (18) comprises a filtering means (43) able of filtering the liquid flow crossing it.

2. Drying machine according to claim 1, **characterized in that** said filtering means (43) can be detached, and preferably extracted, from the body (21) of said valve (18).

3. Drying machine according to claim 2, **characterized in that** said filtering means (43), when introduced into said valve (18), allows the liquid flow, and that when extracted from said valve, the inlet access of said pipe (17) into said valve is automatically closed.

4. Drying machine according to claim 3, **characterized in that** said valve (18) is shaped as an hollow body (21), one end of it being connected to said pipe (17).

5. Drying machine according to claims 3 or 4, **characterized in that** said channel (23), inflowing into said secondary tank (16), is connected to a side portion of said hollow body (21) through a respective opening (40).

6. Drying machine according to one of the claims 4 or 5, **characterized in that** said filtering means (43) comprises a filtering septum (44), preferably provided with close mesh nets.

7. Machine according to claim 6, **characterized in that** said hollow body (21) is provided on its inner surface with an annular relief (45) with an inner opening (46), that a closing member (48) is interposed between said annular relief (45) and the inlet mouth (17-A) of said pipe (17), and is able of closing said inner opening (46), **in that** said filtering means is solidly connected to a first extension (47) turned to said closing member (48) and that said first extension (47) is able to selectively engage by pushing with said closing means (48) so as to allow the liquid flow circulation across said inner opening (46), or to prevent said

circulation.

8. Drying machine according to claim 7, **characterized in that** between said closing member (48) and said first extension (47) a second extension (48-A) is provided, which is firmly associated to said closing member (48) and is apt to contact and be pressed by said first extension (47). 5
9. Drying machine according to claim 8, **characterized in that** said valve (18) is provided with an elastic means (50), interposed between said closing member (48) and the inner end side (55) which is turned to the inlet access of said pipe (17), of said hollow body (20). 10
15
10. Drying machine according to any of the previous claims, **characterized in that** said hollow body (20) and said filtering element (43) can be reciprocally engaged and dis-engaged, preferably through a threading coupling. 20
11. Drying machine according to any of the previous claims, **characterized in that** said filtering means (43) comprises a control means, preferably a rotating knob, placed and accessible on the front side of said machine, apt to selectively engage or disengage it out of said hollow body (20). 25

30

35

40

45

50

55

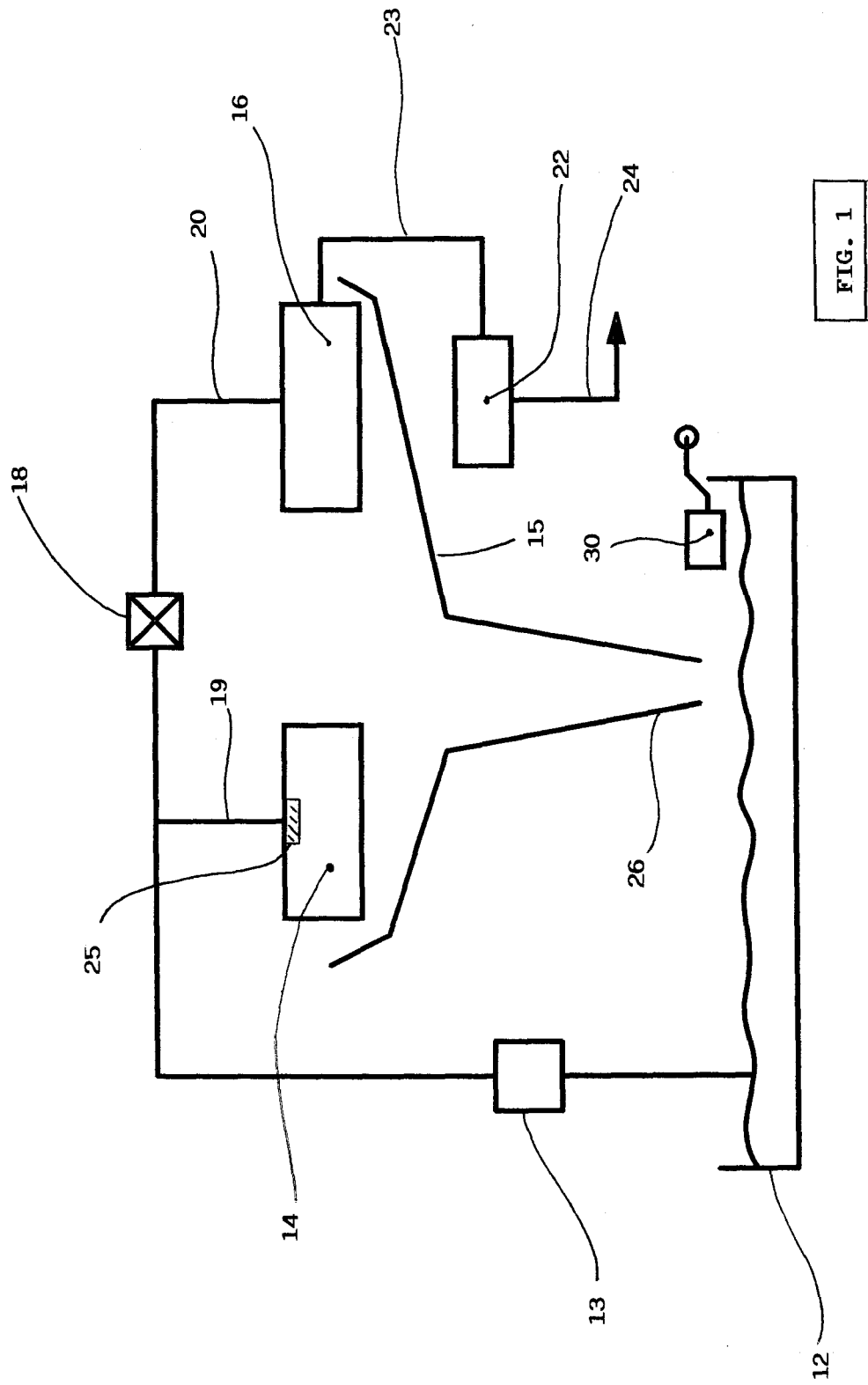

FIG. 1

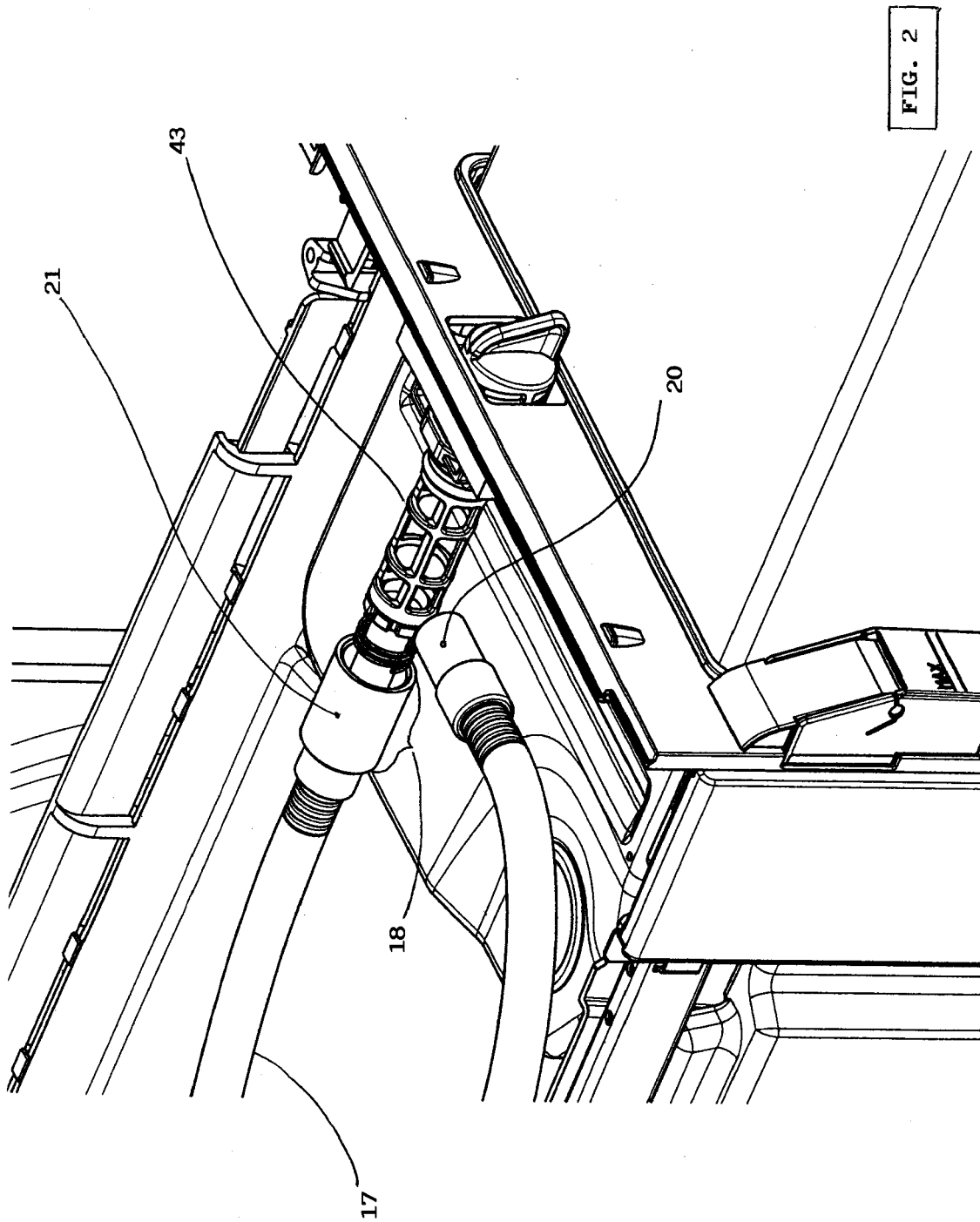
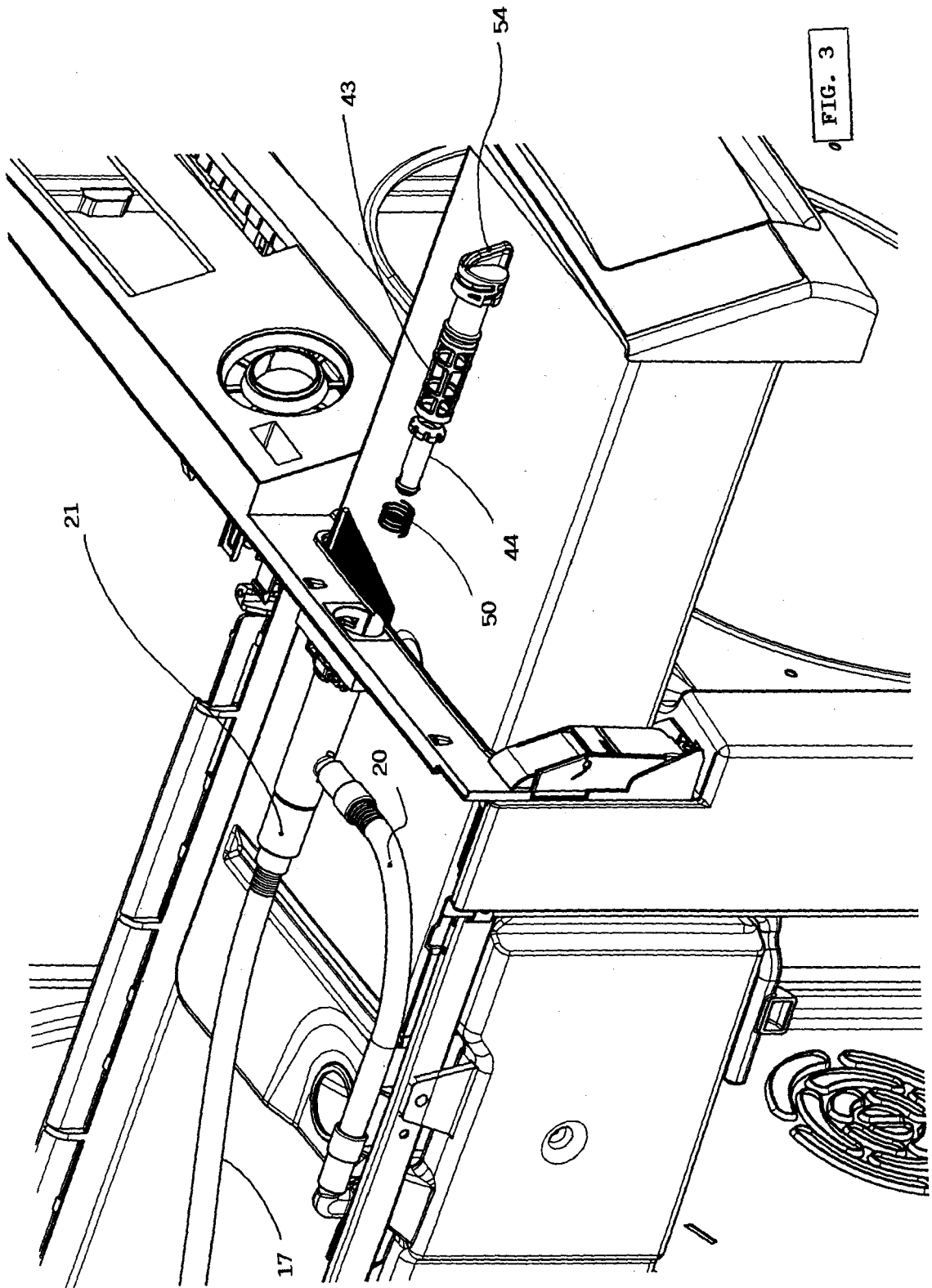

FIG. 2



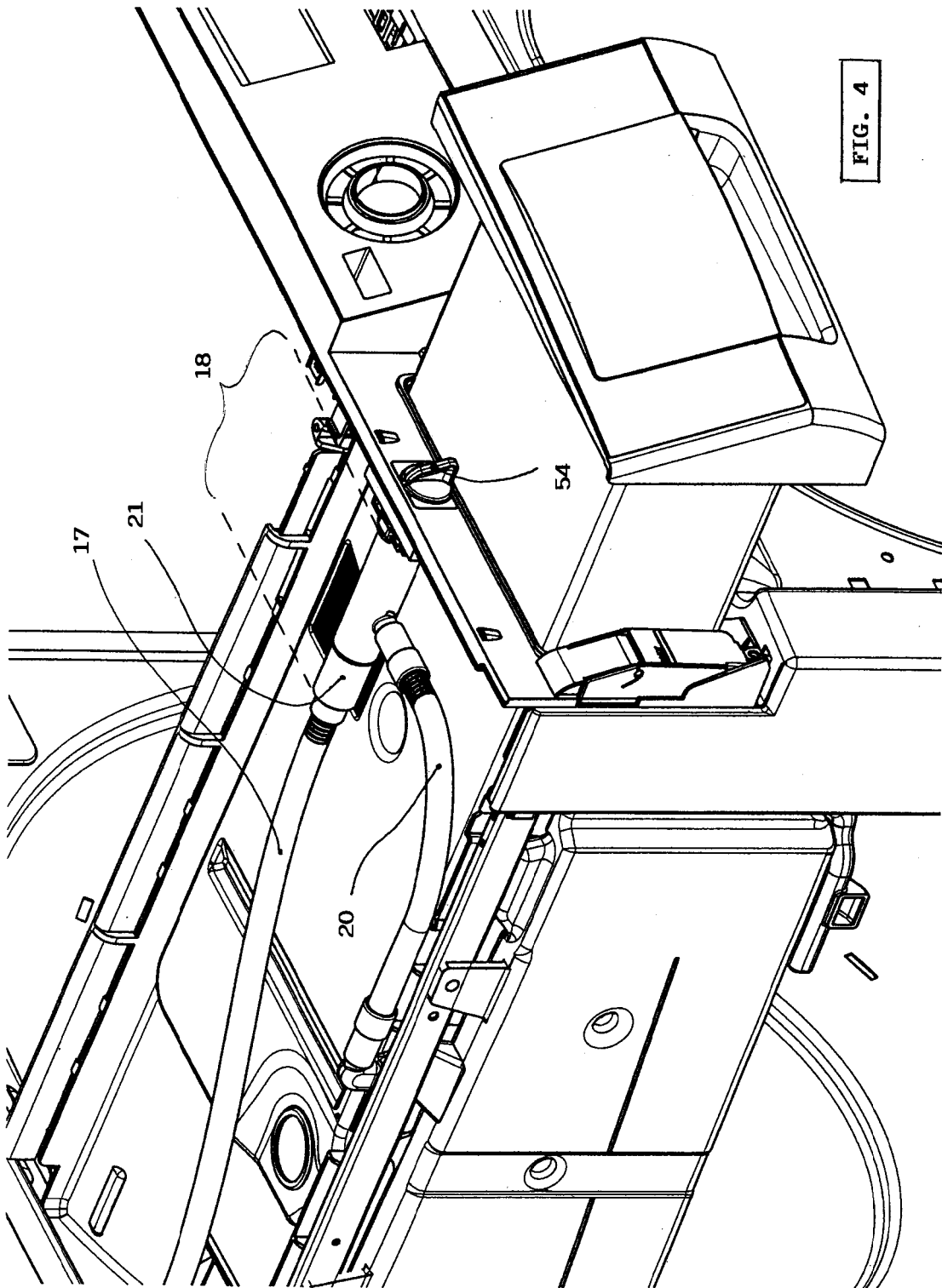
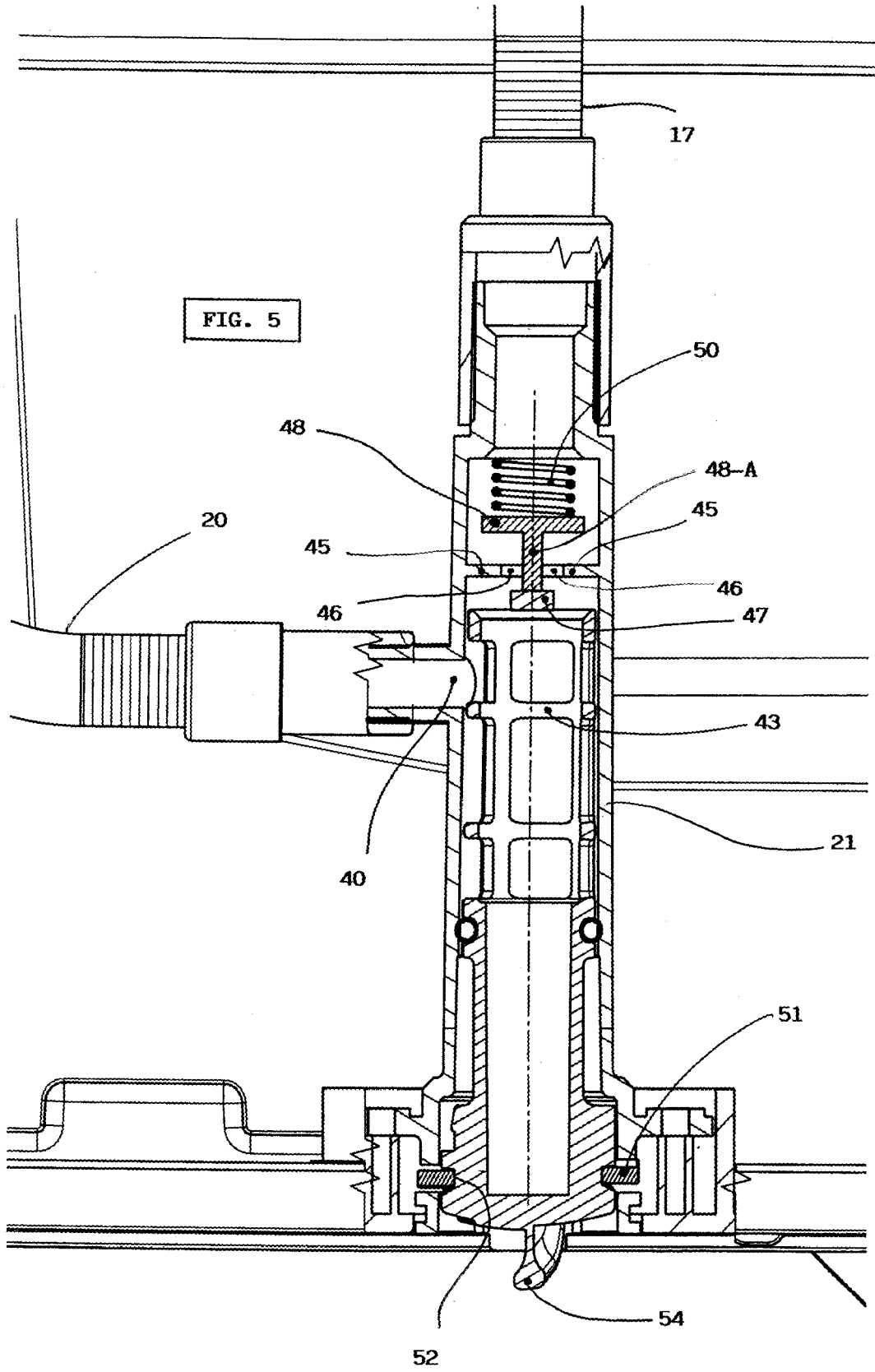
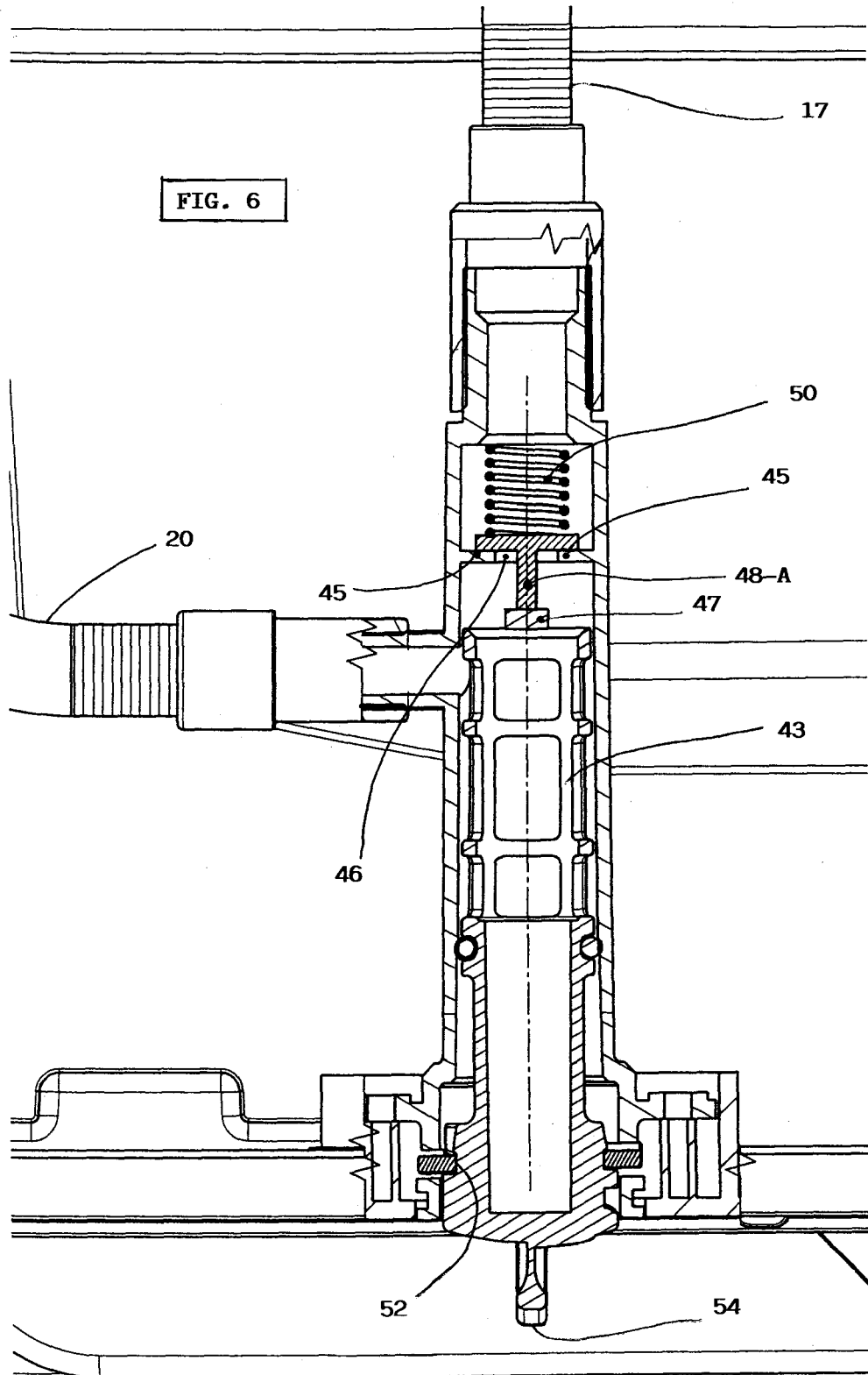

FIG. 4







DOCUMENTS CONSIDERED TO BE RELEVANT			
Category	Citation of document with indication, where appropriate, of relevant passages	Relevant to claim	CLASSIFICATION OF THE APPLICATION (IPC)
A	EP 1 564 325 A (ELECTROLUX HOME PROD CORP [BE]) 17 August 2005 (2005-08-17) * paragraph [0031] - paragraph [0034]; figures 2,3 *	1	INV. D06F58/20 D06F58/24 D06F73/02
A	US 2006/112585 A1 (CHOI SOUNG BONG [KR] ET AL) 1 June 2006 (2006-06-01) * paragraph [0059] - paragraph [0062] * * paragraph [0080] - paragraph [0082] * * figure 3 *	1	
A,D	US 2005/278983 A1 (RYDBERG DON J [US]) 22 December 2005 (2005-12-22) * paragraph [0018] - paragraph [0019]; figures 2,3 *	1	
A,D	DE 102 60 151 A1 (BSH BOSCH SIEMENS HAUSGERAETE [DE]) 1 July 2004 (2004-07-01)		
The present search report has been drawn up for all claims			TECHNICAL FIELDS SEARCHED (IPC)
			D06F
Place of search		Date of completion of the search	Examiner
The Hague		9 October 2007	Courrier, Gilles
CATEGORY OF CITED DOCUMENTS X : particularly relevant if taken alone Y : particularly relevant if combined with another document of the same category A : technological background O : non-written disclosure P : intermediate document T : theory or principle underlying the invention E : earlier patent document, but published on, or after the filing date D : document cited in the application L : document cited for other reasons & : member of the same patent family, corresponding document			

2
EPO FORM 1503 03/02 (P04/C01)

ANNEX TO THE EUROPEAN SEARCH REPORT
ON EUROPEAN PATENT APPLICATION NO.

EP 07 10 8016

This annex lists the patent family members relating to the patent documents cited in the above-mentioned European search report.
The members are as contained in the European Patent Office EDP file on
The European Patent Office is in no way liable for these particulars which are merely given for the purpose of information.

09-10-2007

Patent document cited in search report		Publication date	Patent family member(s)	Publication date
EP 1564325	A	17-08-2005	AU 2005200315 A1	25-08-2005
			CA 2494432 A1	10-08-2005
			US 2005172511 A1	11-08-2005

US 2006112585	A1	01-06-2006	KR 20060046803 A	18-05-2006

US 2005278983	A1	22-12-2005	NONE	

DE 10260151	A1	01-07-2004	WO 2004059070 A1	15-07-2004
			EP 1579052 A1	28-09-2005
			US 2007006484 A1	11-01-2007

REFERENCES CITED IN THE DESCRIPTION

This list of references cited by the applicant is for the reader's convenience only. It does not form part of the European patent document. Even though great care has been taken in compiling the references, errors or omissions cannot be excluded and the EPO disclaims all liability in this regard.

Patent documents cited in the description

- EP 06118596 A [0004] [0017]
- DE 10260151 A1 [0004]
- US 20050278983 A [0010]