

No. 607,677.

Patented July 19, 1898.

W. H. BIERWIRTH.
PHOTOGRAPHIC PLATE WASHER.

(Application filed Apr. 1, 1898.)

(No Model.)

Fig. 1.

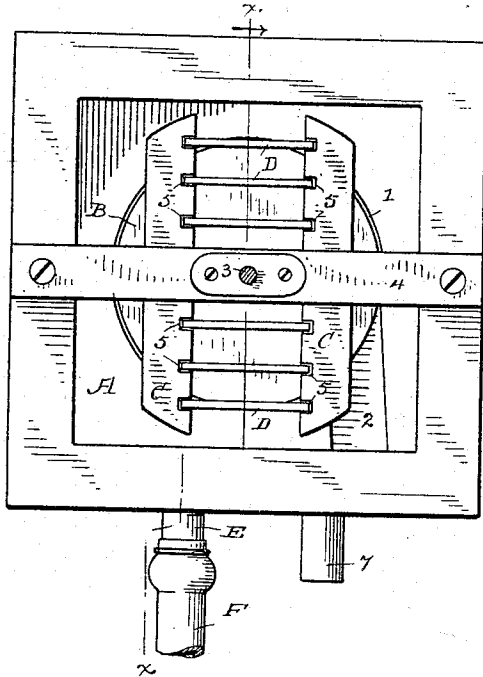

Fig. 3.

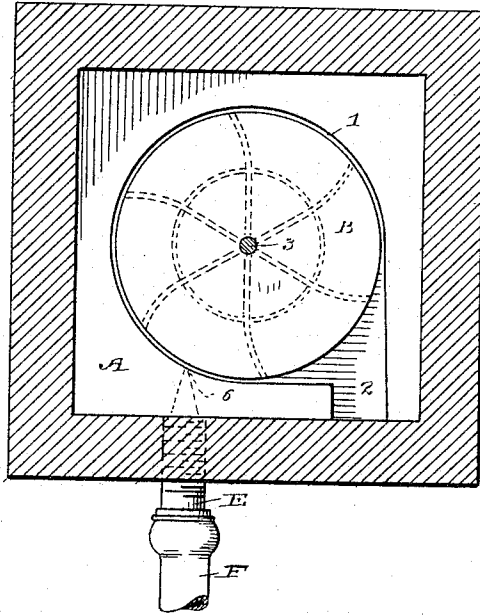
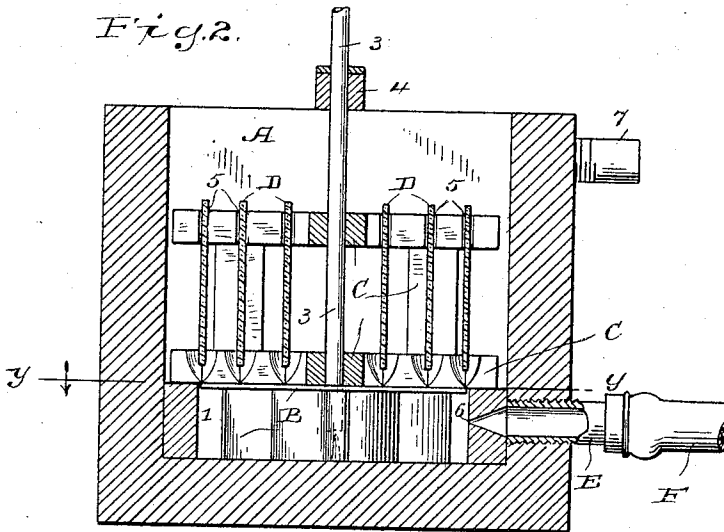

Fig. 2.



WITNESSES

H. H. Lamb
S. Wiley

INVENTOR

William H. Bierwirth
By A. M. Crooster
Att'y.

UNITED STATES PATENT OFFICE.

WILLIAM H. BIERWIRTH, OF TORRINGTON, CONNECTICUT.

PHOTOGRAPHIC-PLATE WASHER.

SPECIFICATION forming part of Letters Patent No. 607,677, dated July 19, 1898.

Application filed April 1, 1898. Serial No. 676,071. (No model.)

To all whom it may concern:

Be it known that I, WILLIAM H. BIERWIRTH, a citizen of the United States, residing at Torrington, county of Litchfield, State of Connecticut, have invented a new and useful Negative-Washer, of which the following is a specification.

My invention has for its object to provide a simple and inexpensive automatic machine for washing photographic negatives, the essential requirements both for professional and amateur photographers' use being that the device be so constructed that it may be used at any place where there is running water, that it wash the negatives as quickly as possible and without the slightest danger of injuring the negatives, and that the operator be relieved from the necessity of watching the machine while it is in use.

With these ends in view I have devised the simple and novel automatic negative-washer of which the following description, in connection with the accompanying drawings, is a specification, letters and numbers being used to designate the several parts.

Figure 1 is a plan view; Fig. 2, a vertical section on the line $x x$ in Fig. 1, and Fig. 3 is a horizontal section on the line $y y$ in Fig. 2.

A denotes a tank which is provided in its bottom with a circular recess 1, which receives a turbine B, and at one side with a recess 2, communicating with recess 1, into which the water passes after leaving the turbine.

3 denotes the shaft of the turbine, which is suitably stepped in the bottom of recess 1 and has a bearing in a cross-piece 4 at the top of the tank.

C denotes a frame which is carried by the shaft and which is provided with slots 5 to receive negatives, which are indicated by D. The shape of the frame is of course not of the essence of my invention. It is simply required that this frame be made of suitable shape and size to receive any required number of negatives and that it be provided with suitable devices—in the present instance slots—to hold them firmly and in such position that the water may pass freely between them and wash both sides simultaneously. Both tank and frame may be made of either wood or metal, as preferred.

E denotes the induction-pipe, to which a

flexible tube F may be attached and which is provided with a contracted orifice, as at 6, through which water passes to the turbine with the necessary force, as will be clearly understood from Figs. 2 and 3. After passing around with the turbine the water passes from recess 1 into recess 2 and from thence rises into the body of the tank, from whence it escapes in any suitable manner, as by an escape-pipe 7.

The mode of operation is that of an ordinary turbine. But a very small quantity of water is required, which passes to the turbine through the contracted orifice with sufficient force to rotate the turbine at any required speed, the speed at which the turbine, and with it, of course, the frame carrying the negatives is rotated, depending upon the force of the water, which may be regulated in any suitable manner by the operator, as by an ordinary faucet, to which the flexible tube may be attached. It will of course be apparent that the water after passing from the turbine will fill the tank and that the negatives carried by the frame will be rotated in the water, both sides of the negatives being fully exposed to the water. I have found in practice that negatives may be washed in this manner in a perfectly satisfactory manner and much more quickly than is possible in any manner heretofore known to the trade.

I am aware that it has been proposed to construct a washer for photographic prints with a perforated cylinder mounted to rotate on a horizontal axis, one end of said cylinder being provided with blades against which the supply of water impinges to rotate the cylinder, the whole being placed in a tank having an overflow; but such device differs from my invention materially in that it comprises no means whatever for holding negatives so as to prevent their having any movement relatively to each other or to the frame which supports them.

Having thus described my invention, I claim—

1. A negative-washer comprising a tank, a turbine stepped therein and carrying a rotary frame provided with suitable means for holding negatives against movement relatively to the frame.

2. A negative-washer comprising a tank

having in its bottom a recess, a turbine stepped
in said recess, a frame within the tank which
is carried by the turbine, an induction-pipe
by which water is supplied to the turbine and
5 an escape-pipe above the turbine so that the
water which drives the turbine will rise in the
tank and wash both sides of the negatives as
they are carried about by the frame, said
frame being provided with means for hold-
10 ing negatives against movement relatively to
the frame.

3. A negative-washer comprising a tank
having in its bottom a recess, a turbine stepped
in said recess, and a frame carried by the tur-
bine and provided with notches to receive 15
negatives.

In testimony whereof I affix my signature
in presence of two witnesses.

WILLIAM H. BIERWIRTH.

Witnesses:

WALTER HOLCOMB,
CHARLES H. LAWTON.