



(12) **EUROPEAN PATENT APPLICATION**

(43) Date of publication: **13.09.2006 Bulletin 2006/37** (51) Int Cl.: **A47H 1/02 (2006.01)**

(21) Application number: **06251312.2**

(22) Date of filing: **13.03.2006**

(84) Designated Contracting States:
**AT BE BG CH CY CZ DE DK EE ES FI FR GB GR
HU IE IS IT LI LT LU LV MC NL PL PT RO SE SI
SK TR**
Designated Extension States:
AL BA HR MK YU

(72) Inventor: **Gualtieri, Orazio**
London, N16 0QL (GB)

(74) Representative: **Townsend, Victoria Jayne et al**
FRY HEATH & SPENCE LLP
The Gables
Massetts Road
Horley,
Surrey RH6 7DQ (GB)

(30) Priority: **11.03.2005 GB 0505032**

(71) Applicant: **Gualtieri, Orazio**
London, N16 0QL (GB)

(54) **Curtain pole**

(57) A curtain pole (4) having a generally circular cross-section with at least one flattened side (12). The curtain pole (4) consists of a plurality of pole pieces (6, 8, 10) which are connected together to produce a curtain pole (4) having a centre line which diverges from the centre of line of the original uncut pole.

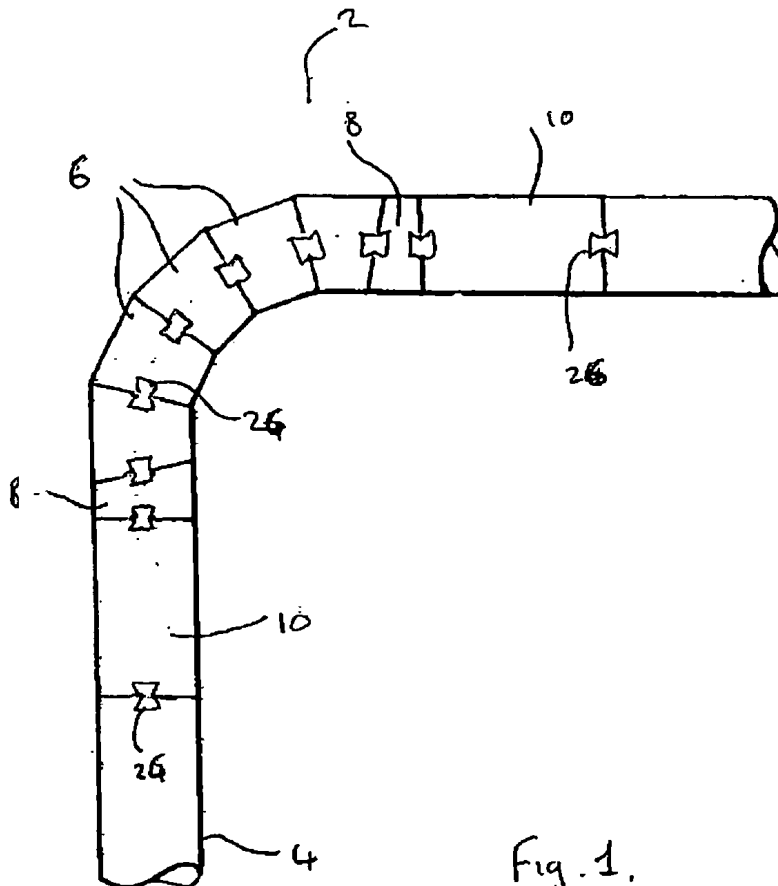

Fig. 1.

Description

[0001] The present invention relates to curtain poles.

5 **[0002]** Curtain poles are used extensively for hanging curtains. The usual form of such devices comprises an elongate pole, generally but not always made of wood, which carries rings, slidable along the pole, from which the curtains are suspended. The pole itself is supported adjacent to its ends, and at its midpoint when the pole is intended for use with a pair of curtains.

[0003] Such known curtain poles are very successful for use with straight windows. They cannot however be used effectively for full-bay or semi-bay windows where bending would be required.

10 **[0004]** The present invention seeks to provide a pole construction which enables curtain poles to follow a bend without significantly detracting from the appearance of the pole.

[0005] The applicant's earlier patent no. GB234834 relates to a pole corner arrangement to allow curtain poles to be used in locations where a bend is required. Although the product has proven reasonably successful, the applicant has found a number of disadvantages with the construction. In particular, it has proven to be extremely difficult accurately to cut the wooden corner pieces to the desired angles and planes to allow accurate abutment of the corner pieces. Furthermore, movement between the corner pieces of the pole causes a force to be exerted at the areas in which the pole is supported to the wall, resulting in movement of the pole at these points when the curtains are opened or drawn.

[0006] These disadvantages are undesirable and detract from the appearance and practical use of the pole.

20 **[0007]** The present invention seeks to provide an improved pole construction to overcome or at least alleviate the aforementioned disadvantages.

[0008] According to one aspect of the invention, there is provided a supporting pole for connection to wall surface, the pole having a circular or substantially circular cross-section with at least one flattened side.

[0009] According to a further aspect of the invention, there is provided a curtain pole having a circular or substantially circular cross section with at least one flattened side, the pole comprising a plurality of the pole pieces each cut transversely from a unitary pole and having at one or each end an inclined face, and means for connecting the pole pieces together to produce a unitary pole having a centre line which diverges from the centre line of the original uncut pole.

25 **[0010]** Preferably the pole pieces and adjacent pole parts are formed with recesses for connection together via dovetail joints.

[0011] The invention will now be described by way of example with reference to the accompanying drawings, in which :

30 Figure 1 is a plan view of a corner arrangement of a curtain pole constructed in accordance with the present invention;

Figure 2 is a perspective view of an intermediate pole piece used in the arrangement of Figure 1;

35 Figure 3 is a sectional view taken through X-X of the pole piece of Figure 2;

Figure 4 is a sectional view taken through Y-Y of the pole piece of Figure 2;

40 Figure 5 is a sectional view of an end pole piece used in the arrangement of Figure 1;

Figure 6 shows a perspective view of a clamp suitable for use in the arrangement of Figure 1; and

Figure 7 shows a perspective view of a further clamp suitable for use in the arrangement of Figure 1.

45 **[0012]** Figure 1 shows a corner arrangement 2 for a curtain pole 4. The corner arrangement comprises five intermediate pole pieces 6 and two end pole pieces 8. Each end pole piece 8 is connected to adjacent pole parts 10.

[0013] Figures 2 to 4 show, in perspective and cross-section, an intermediate pole piece 6. The pole piece 6 is of short length and has a circular cross section with one flattened side 12. The ends 14, 16 of the pole piece 6 are transversely slanted at an angle to the diametral plane, indicated at 18. Both ends are slanted in opposite directions by the same angle so as to form an isosceles wedge like formation in plan view. The angle may, for example, be 15 ° but other angles may be used.

[0014] Figure 6 shows an end pole piece 8. The only difference between the intermediate pole piece 6 and the end pole piece 8 is that the end pole piece 8 has only one slanted end surface 20, the other end surface 22 lies in the diametral plane at right angles to the axis of the pole piece 8.

55 **[0015]** The intermediate and end pole pieces 6, 8 have a recess 24 formed in both end walls 14, 16, 20, 22. As can be seen in Figure 1, the pole pieces 6, 8, 10 are all connected together via dovetail-shaped wedges 26 received within the recesses 24 formed in the end walls of each pole piece 6, 8, 10.

[0016] Adhesive may be additionally used to retain the pole pieces 6, 8, 10 firmly against one another without the

need for a tensioning element. The pole pieces 6, 8, 10 are attached together in such a way that the resultant pole formed has a flattened side extending along the entire length of the pole 4.

[0017] The fact that the pole pieces 6, 8, 10 have a flattened sides allows the end surfaces 14, 16 to be accurately cut to the desired angle .

[0018] In a further embodiment (not shown) a strip of nylon, or similar material, is located on the top surface of the pole pieces and parts 6, 8, 10 and extends along the length of the entire pole 4 to allow curtain rings placed around the pole 4 to slide back and forth along the pole without being subjected to frictional forces.

[0019] In a further embodiment (also not shown) the bottom surface of the pole pieces and parts 6, 8, 10 includes a recess for receiving a track, made for example of aluminium, which extends along the entire length of the pole 4. The track includes attachment members slidable back and forth along the track to which curtains can be attached.

[0020] Figure 6 illustrates a wall clamp 30 suitable for attaching the curtain pole 4 to a wall. The wall clamp 30 comprises a back plate 32 for attachment to a walled surface. The plate 32 has apertures formed therethrough to allow the plate 32 be attached to the wall using conventional means. A U-shaped connecting plate 34 extends perpendicularly from the back plate 32. The connecting plate 34 has elongate apertures 36 formed in each side wall.

[0021] The wall clamp 30 is connected to a curtain pole clamp 36. The pole clamp 36 comprises a back plate 38 which, in use, is attached to the flattened side surface 12 of the pole 4. A connecting plate 40 extends perpendicularly from the back plate 38. The connecting plate 40 has an aperture 42 extending therethrough.

[0022] The connecting plate 40 of the pole clamp 36, in use, is placed within the side walls of the U-shaped connecting plate 34 and the two plates 34, 40 are connected together via the conventional nut and bolt arrangement through the apertures 36, 42. The elongate apertures 36 of the connecting plate 34 allows for adjustment of the connection between the clamps 30, 36.

[0023] Figure 7 illustrates a further wall clamp 44 suitable for attaching the curtain pole 4 to a wall. The wall clamp 44 comprises a back plate 46 for attachment to a walled surface. The plate 46 has apertures formed therethrough to allow the plate 46 to be attached to the wall using conventional means. A connecting plate 48 extends perpendicularly from the top edge of back plate. An elongate aperture 50 is formed through a central area of the top plate.

[0024] An identically shaped curtain clamp 52 has a connecting plate 54 for attachment to the flattened side surfaces 12 of the pole.

[0025] The two clamps 44, 52 are connected together via a conventional nut and bolt arrangement through the elongate apertures 50, 56. The elongate apertures 50, 56 of the connecting plates 48, 54 allows for adjustment of the connection between the clamps 44, 52.

[0026] It will be appreciated that the pole and clamp embodiments described above may be modified without departing from the scope of the invention. For example, although a single right angled corner has been shown, the arrangement of the invention can provide any suitable type of bend which can be achieved by selection of the right number of intermediate pieces 6. Thus it is envisaged that shallow curves and steep curves be allowed for as well as more sophisticated shapes such as "S" bends.

[0027] The above described embodiment has been given by way of example only, and the skilled reader will naturally appreciate that many variations could be made thereto without departing from the scope of the present invention.

Claims

1. A supporting pole (4) for connection to a wall surface, **characterised in** the pole (4) having a generally circular cross-section with at least one flattened side (12).
2. A supporting pole (4) according to claim 1, wherein the pole (4) comprises a plurality of the pole pieces (6, 8, 10) each cut transversely from a unitary pole and having at one or each end (14, 16) an inclined face (20), and means for connecting the pole pieces together (24, 26) to produce a unitary pole having a centre line which diverges from the centre line of the original uncut pole.
3. A supporting pole (4) according to claim 2, wherein the pole pieces (6, 8, 10) and adjacent pole parts (6, 8, 10) are formed with recesses (24) for connection together via dovetail joints (26).
4. A supporting pole (4) according to claim 2 or claim 3, wherein the pole pieces (6, 8, 10) include two end pieces (8) and at least one intermediate piece (6).
5. A supporting pole (4) according to claim 4, wherein the or each intermediate pole piece (6) has opposing end surfaces (14, 16) which are slanted in opposite directions to form a generally isosceles wedge-like formation in plan view.

EP 1 700 546 A2

6. A supporting pole (4) according to claim 5, wherein each end surface (14, 16) is slanted at an angle of between 10 and 20 degrees.
7. A supporting pole (4) according to claim 6, wherein each end surface (14, 16) is slanted at an angle of 15 degrees.
8. A supporting pole (4) according to any one of claims 4 to 7, wherein each end pole piece (8) has one slanted end surface (20) and one end surface (22) that lies in the diametrical plane at right angles to the axis of the pole piece (8).
9. A supporting pole (4) according to any preceding claim further comprising means to attach at least one curtain ring to the pole (4) and means to allow the or each curtain ring to slide along the pole (4).
10. A supporting pole (4) according to claim 9, wherein the attachment means comprises a track received within a continuous recess formed in the bottom surface of each pole piece (6, 8, 10), the track including attachment members slidable along the track to which curtain rings can be attached in use.

5

10

15

20

25

30

35

40

45

50

55

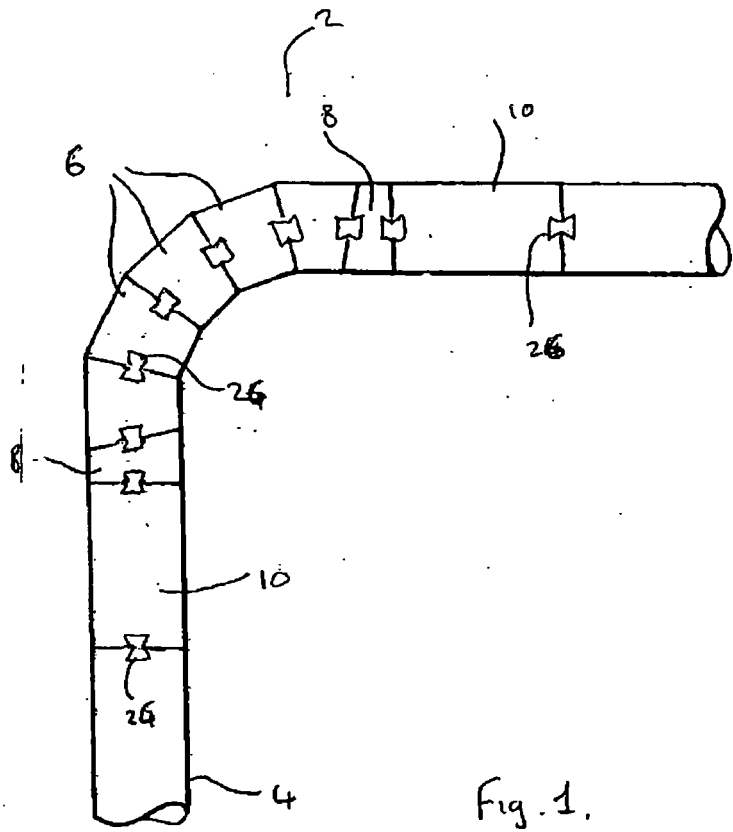

Fig. 1.

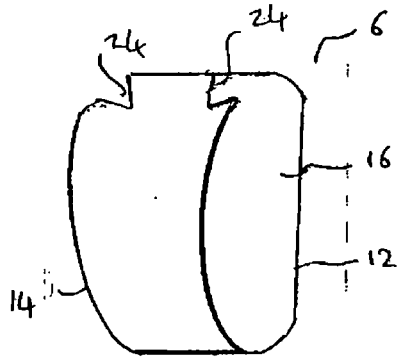

Fig. 2.

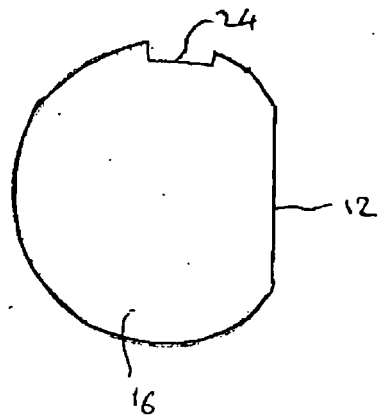

Fig. 3.

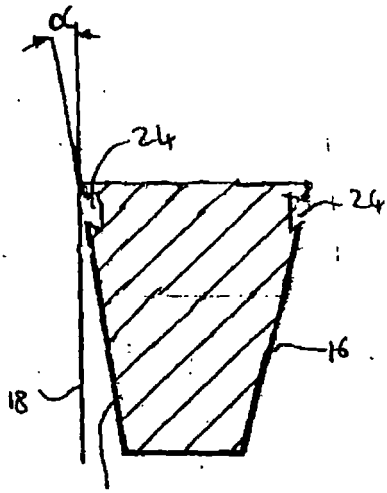

Fig. 4.

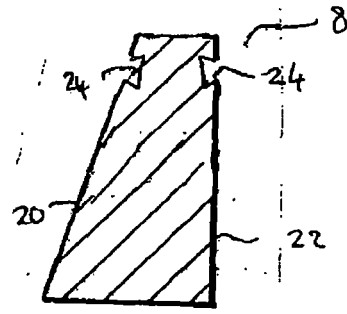

Fig. 5.

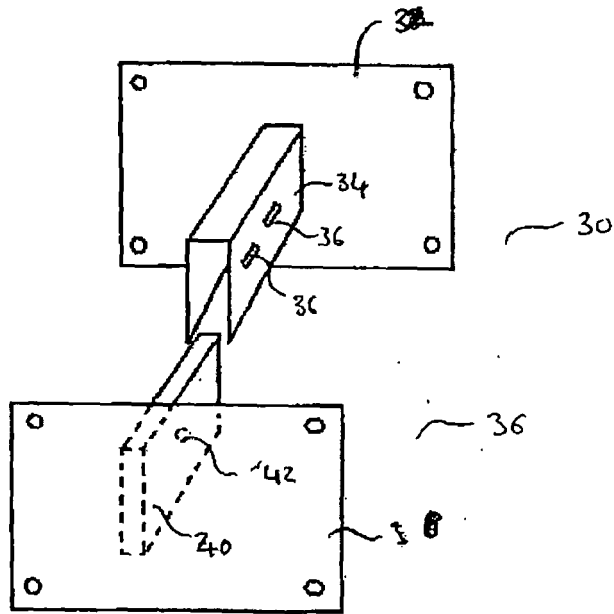

Fig. 6.

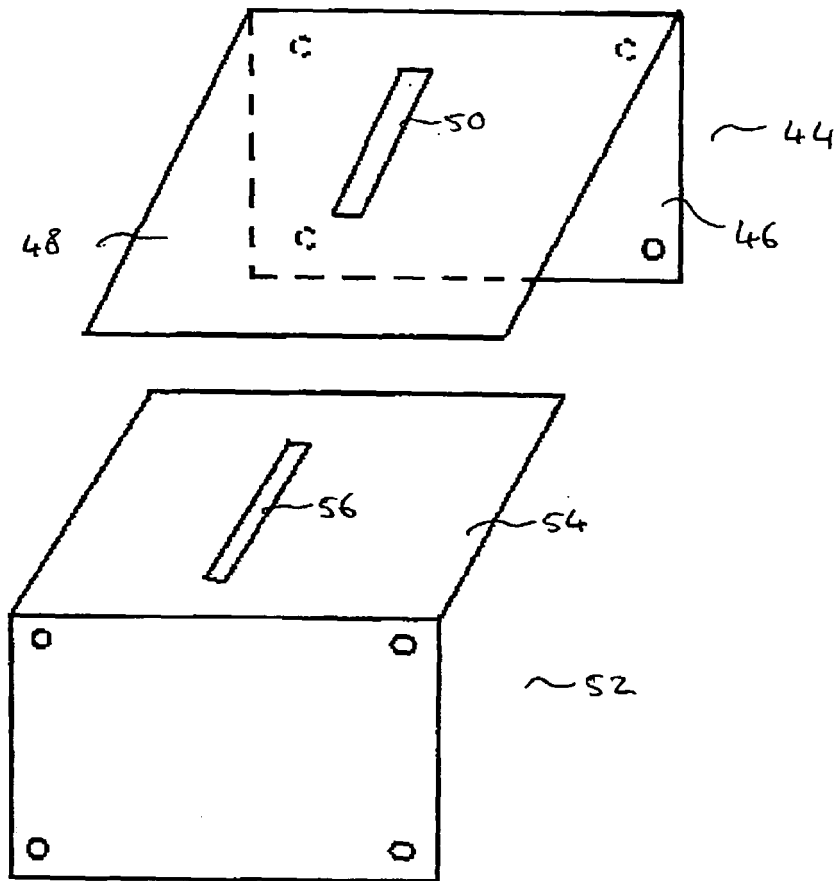

Fig. 7.

REFERENCES CITED IN THE DESCRIPTION

This list of references cited by the applicant is for the reader's convenience only. It does not form part of the European patent document. Even though great care has been taken in compiling the references, errors or omissions cannot be excluded and the EPO disclaims all liability in this regard.

Patent documents cited in the description

- GB 234834 A [0005]