



US 20060054330A1

(19) **United States**

(12) **Patent Application Publication**  
**Ring et al.**

(10) **Pub. No.: US 2006/0054330 A1**

(43) **Pub. Date: Mar. 16, 2006**

(54) **MONO DIAMETER WELLBORE CASING**

**Related U.S. Application Data**

(76) Inventors: **Lev Ring**, Houston, TX (US); **Brock Wayne Watson**, Carrollton, TX (US); **David Paul Brisco**, Duncan, OK (US)

(60) Provisional application No. 60/412,542, filed on Sep. 20, 2002.

**Publication Classification**

Correspondence Address:  
**HAYNES AND BOONE, LLP**  
**901 MAIN STREET, SUITE 3100**  
**DALLAS, TX 75202 (US)**

(51) **Int. Cl.**  
*E21B 43/10* (2006.01)  
(52) **U.S. Cl.** ..... **166/380**; 166/242.1; 166/207

(57) **ABSTRACT**

An apparatus for radially expanding and plastically deforming an expandable tubular members to form a mono diameter wellbore casing includes an adjustable expansion assembly having a first diameter for forming a bell portion of in each tubular member and a second diameter for forming a mono diameter portion that nests into the bell portion of the preceding tubular member.

(21) Appl. No.: **10/528,219**

(22) PCT Filed: **Sep. 22, 2003**

(86) PCT No.: **PCT/US03/29859**

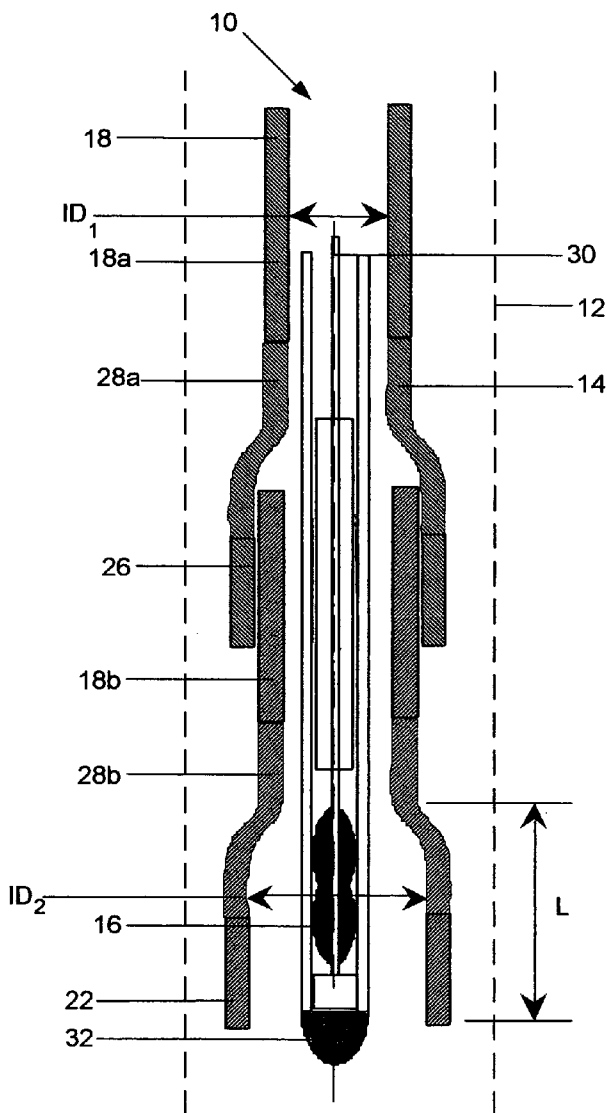

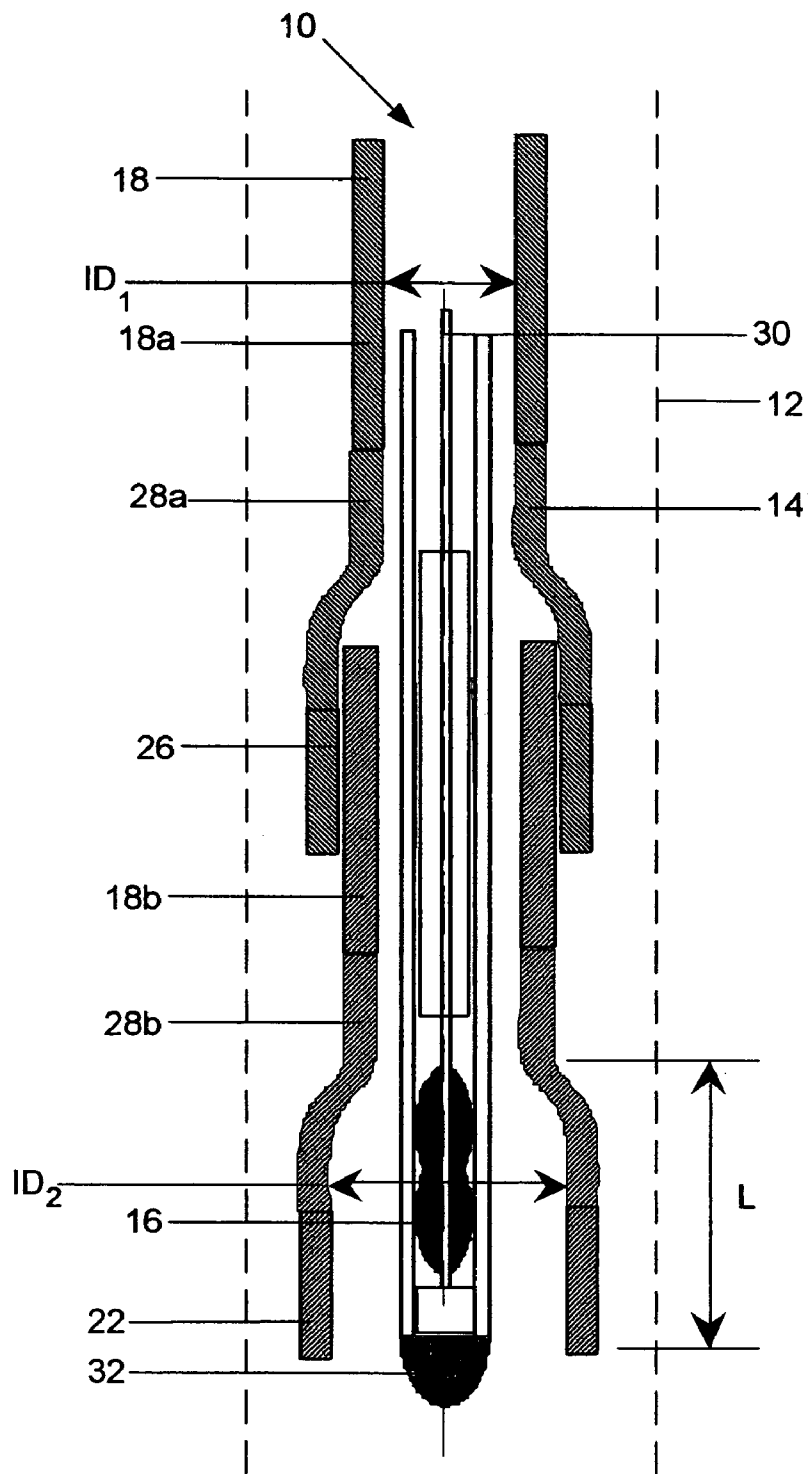

Fig. 1

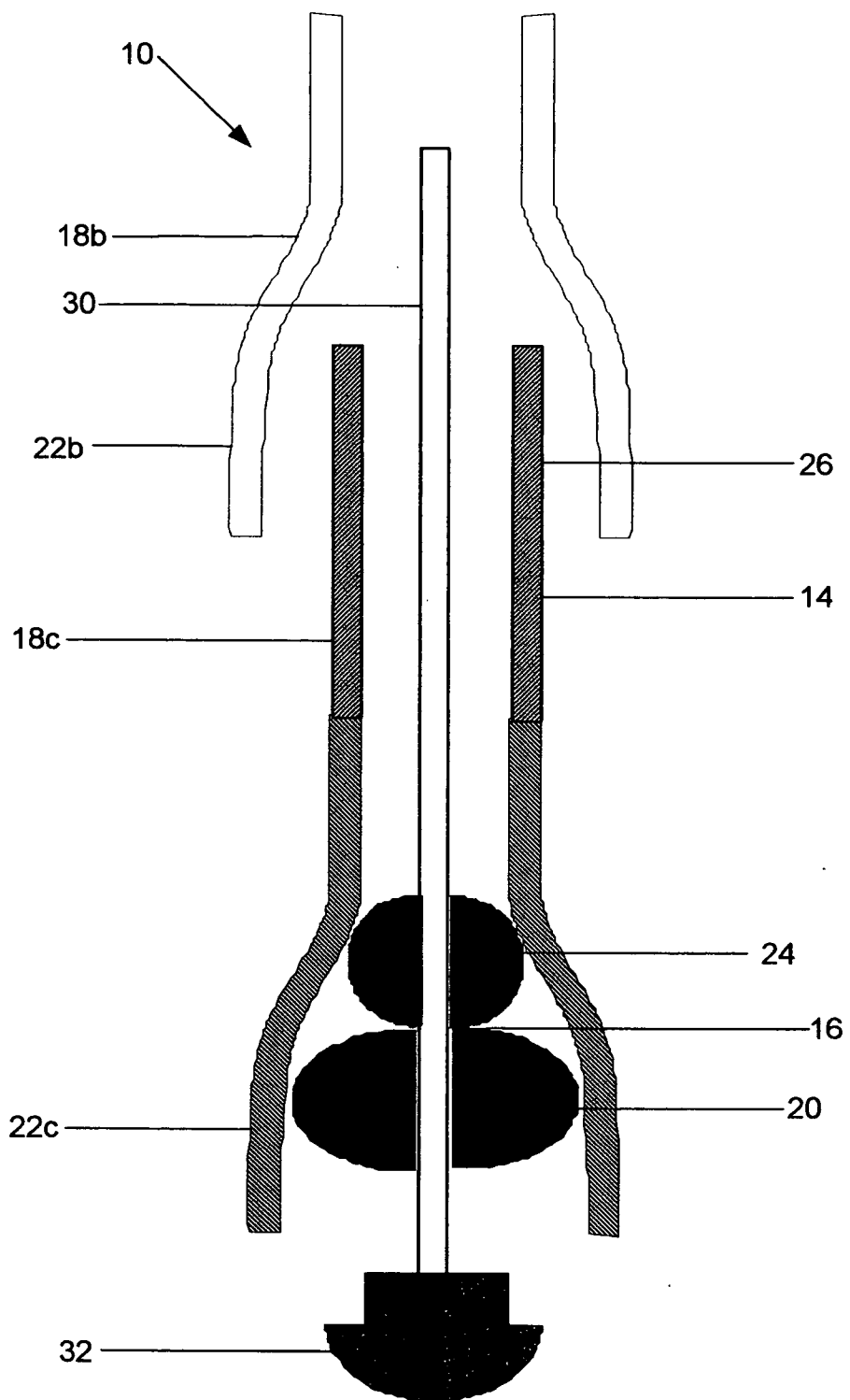

Fig. 2

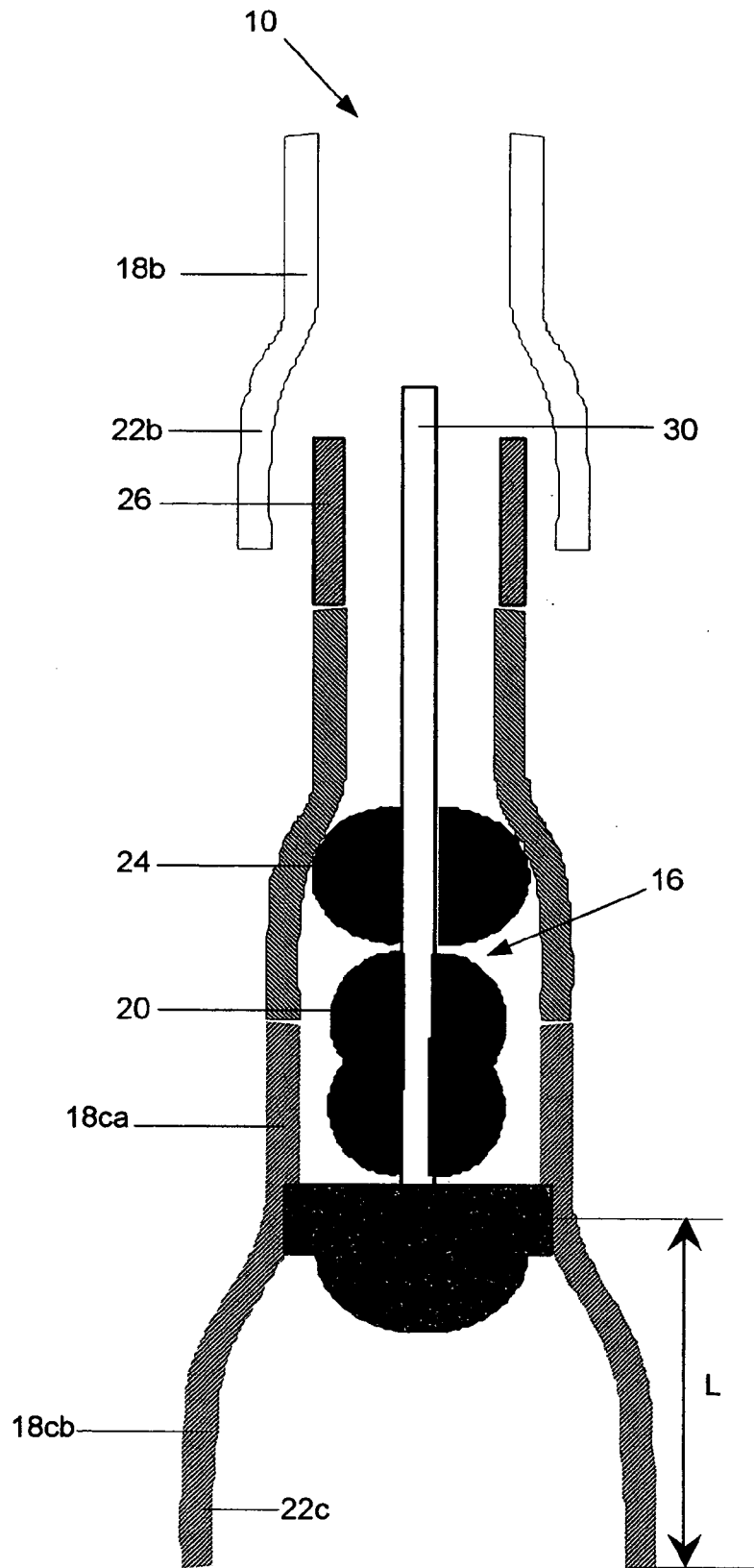

Fig. 3

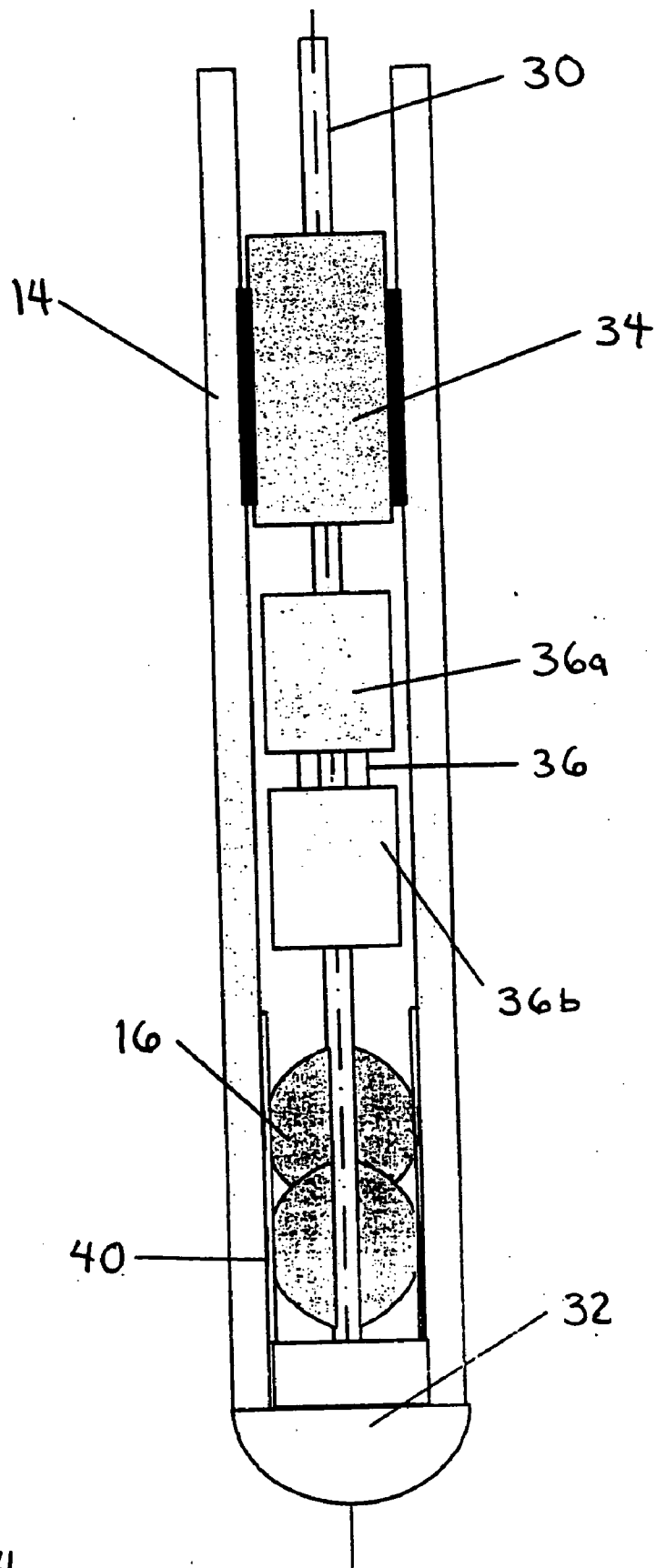
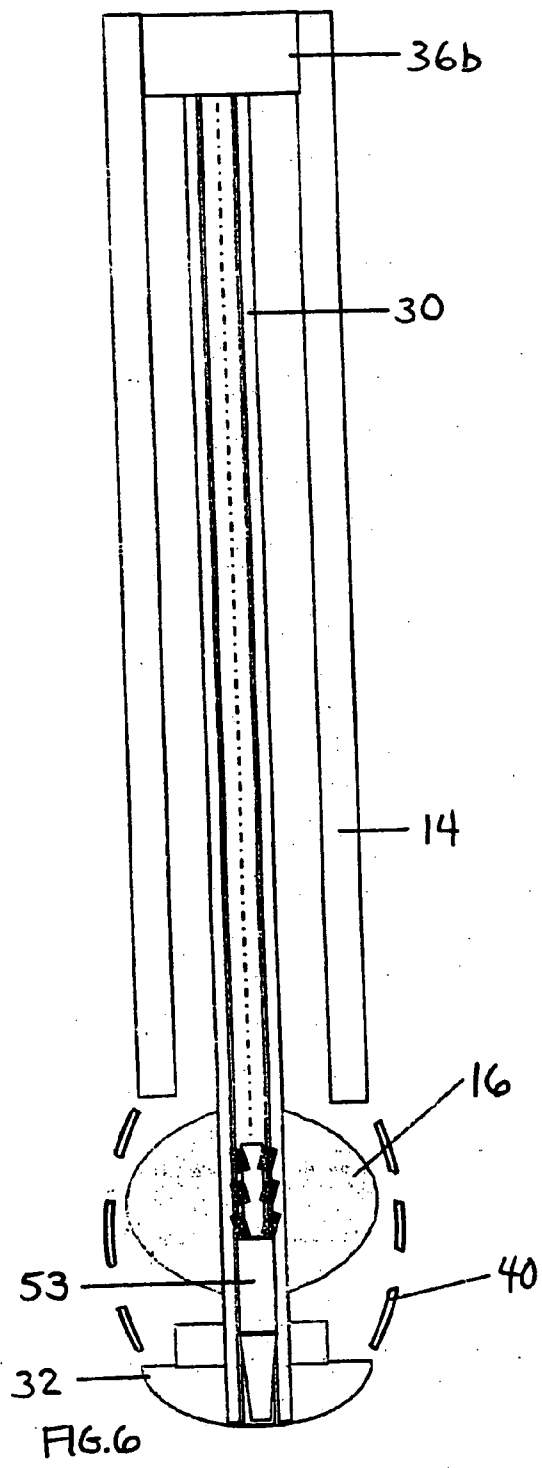
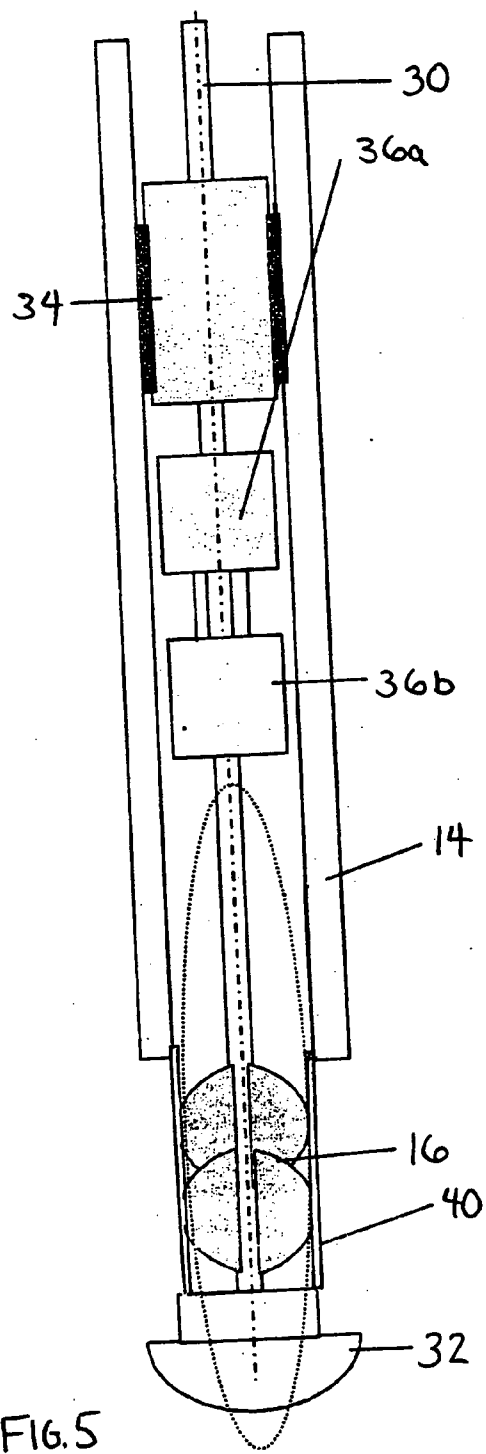

FIG. 4



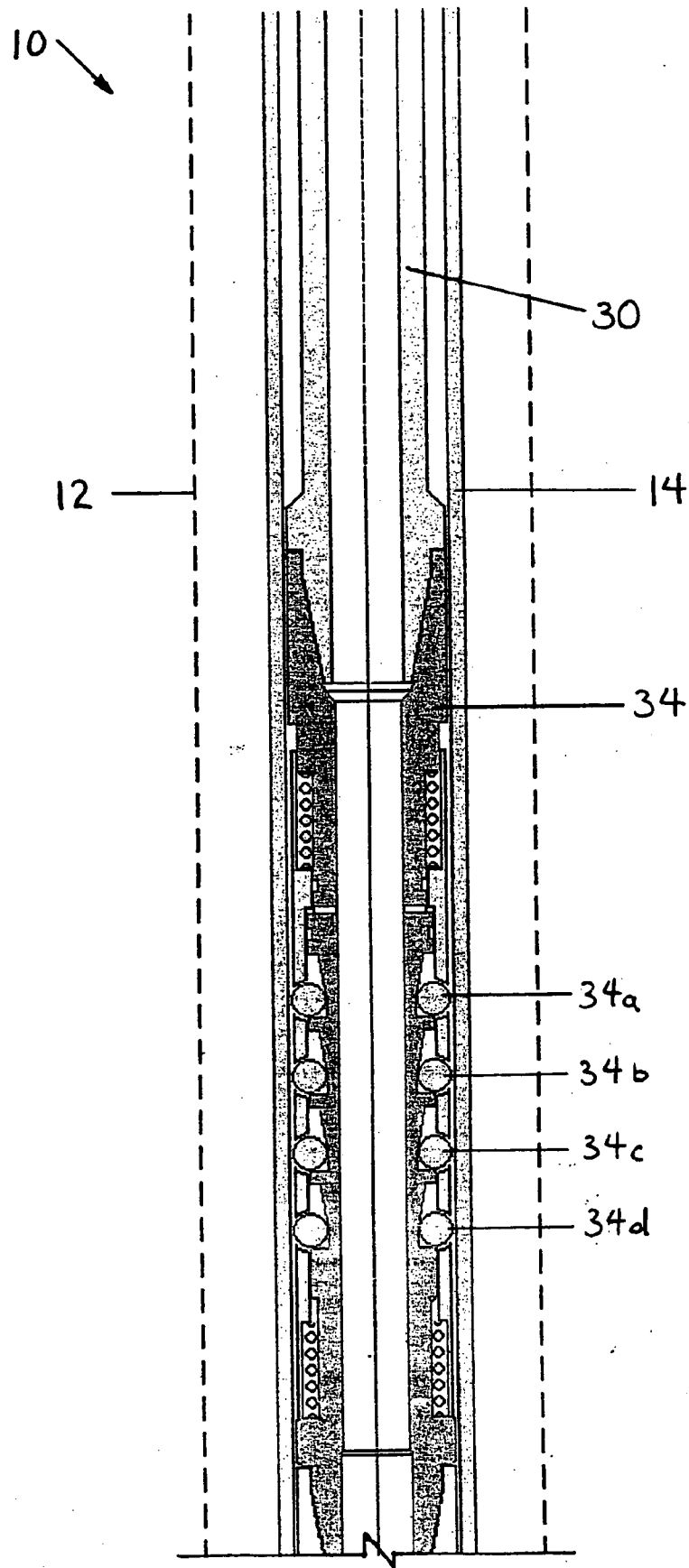

Fig. 7a

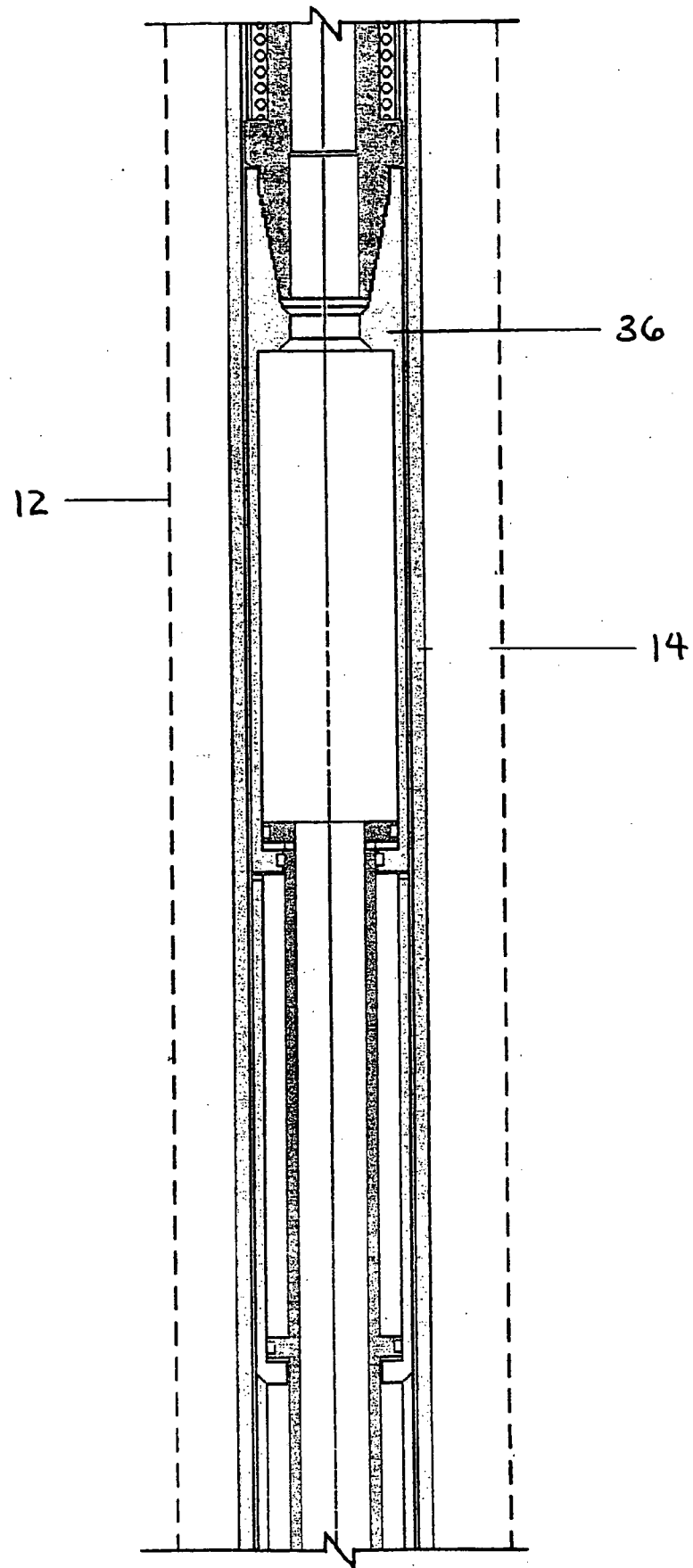

Fig. 7b



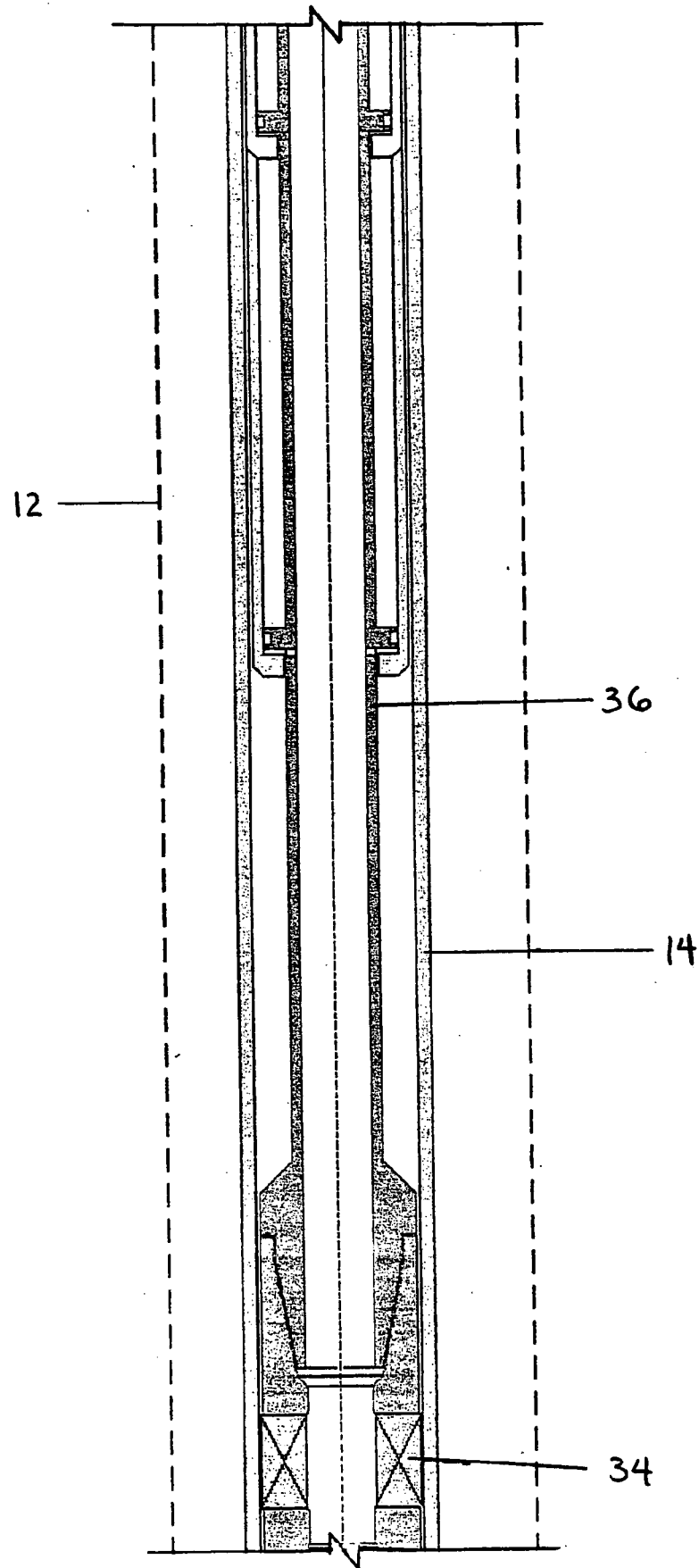

Fig 7c

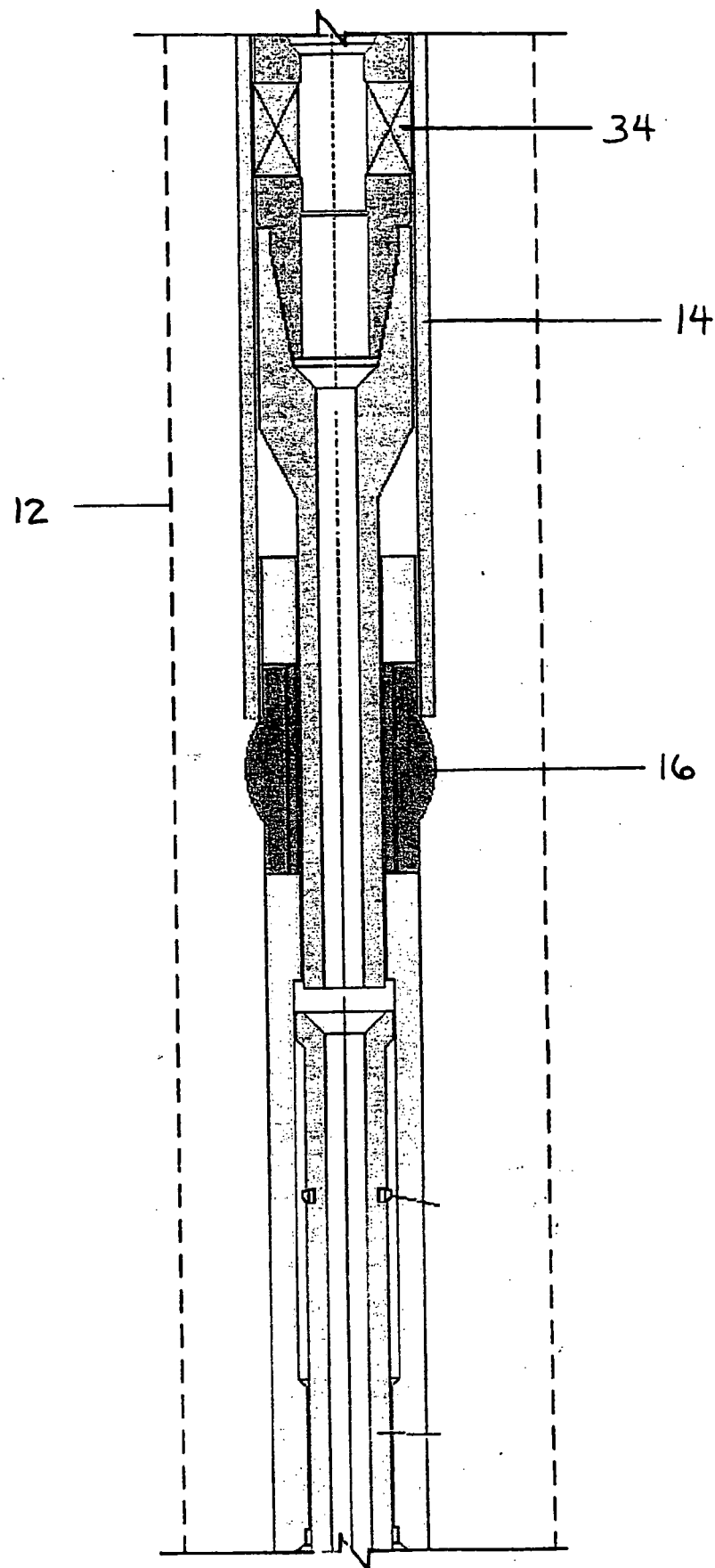

Fig. 7d

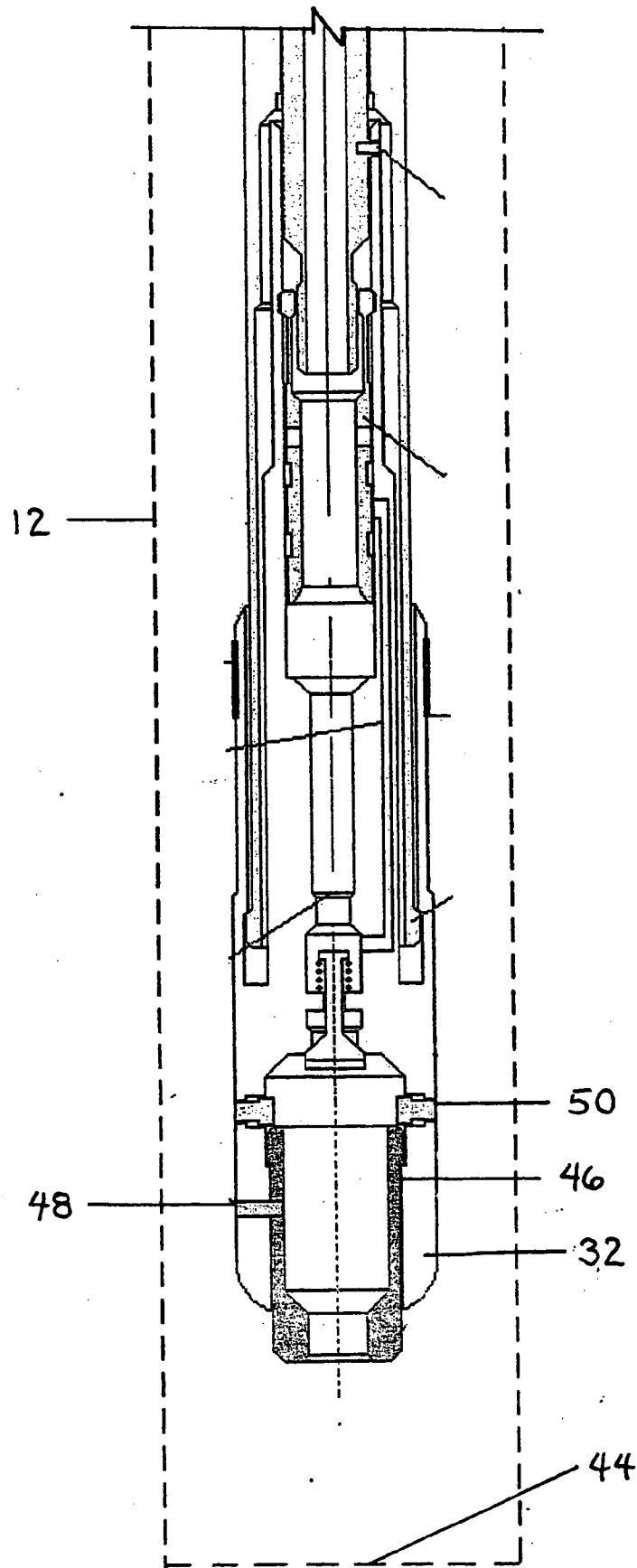

Fig. 7e

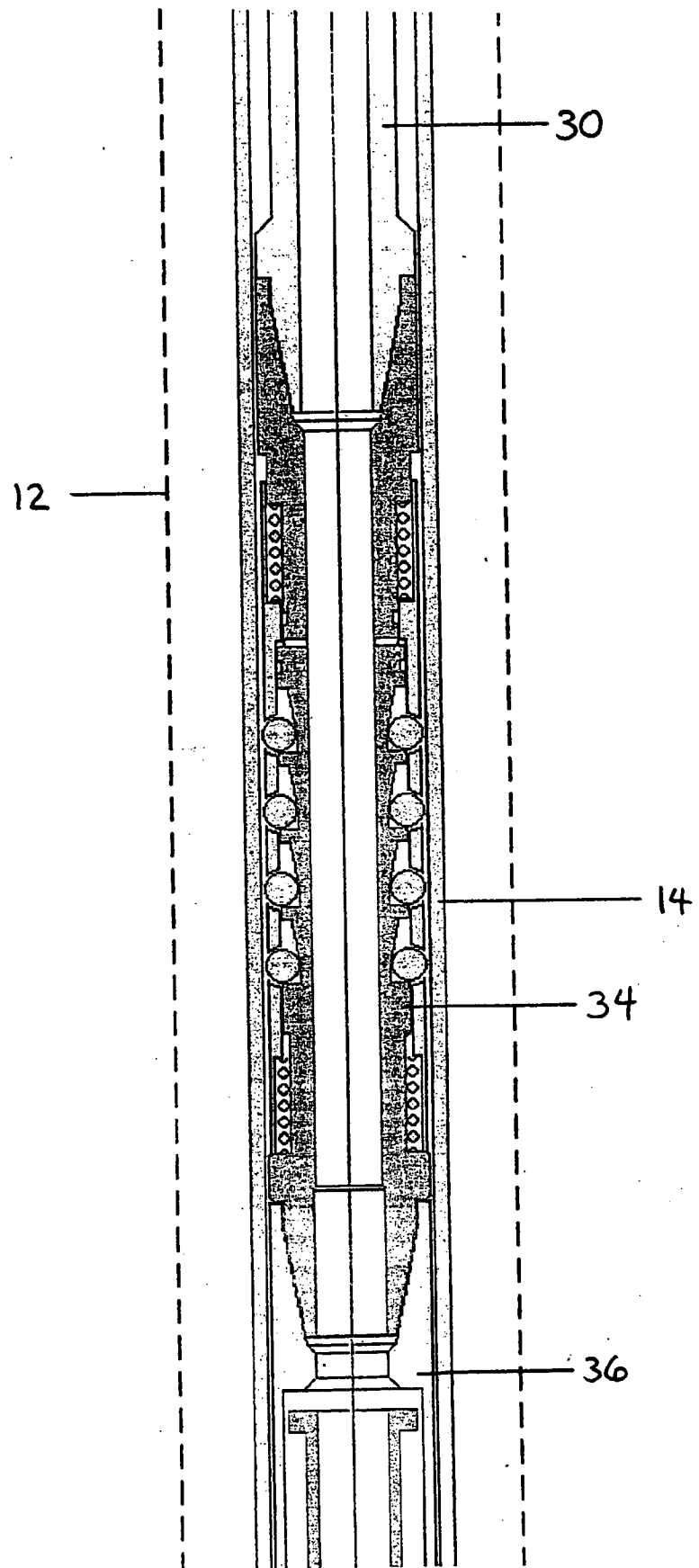

Fig. 8a

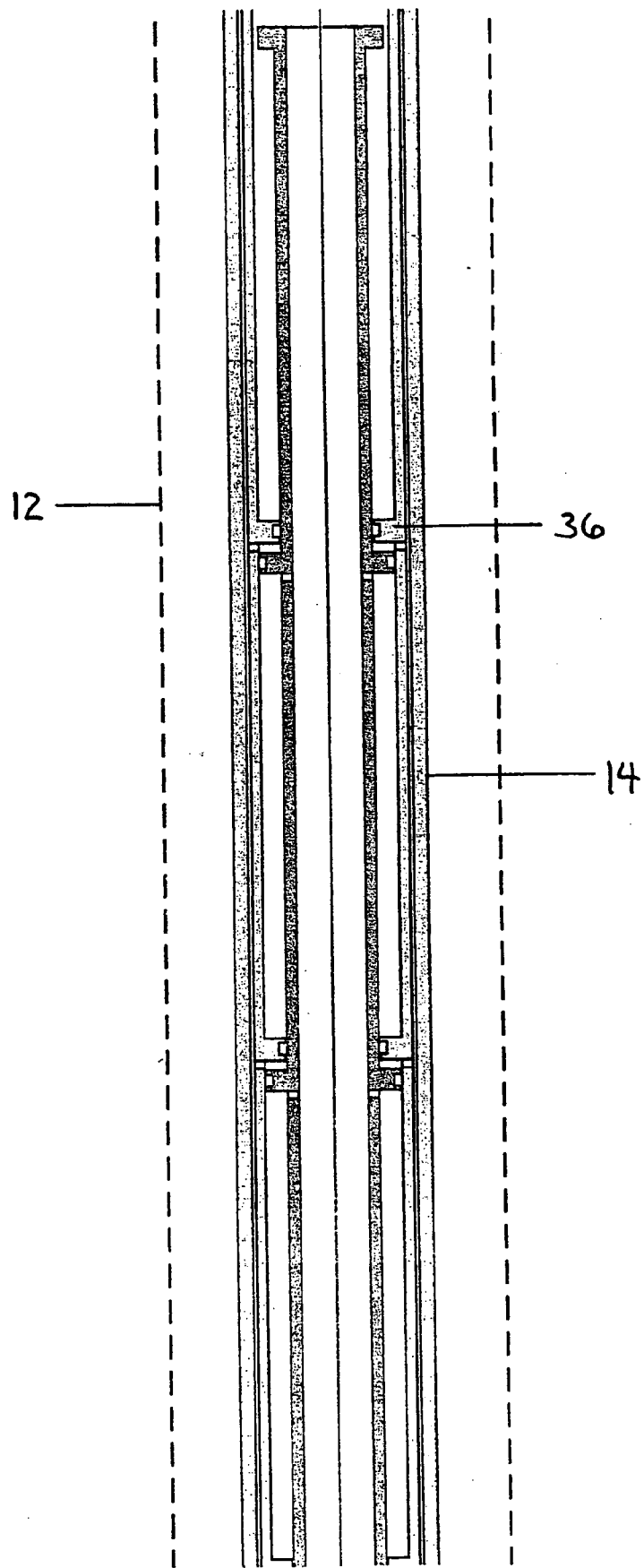

Fig. 8b

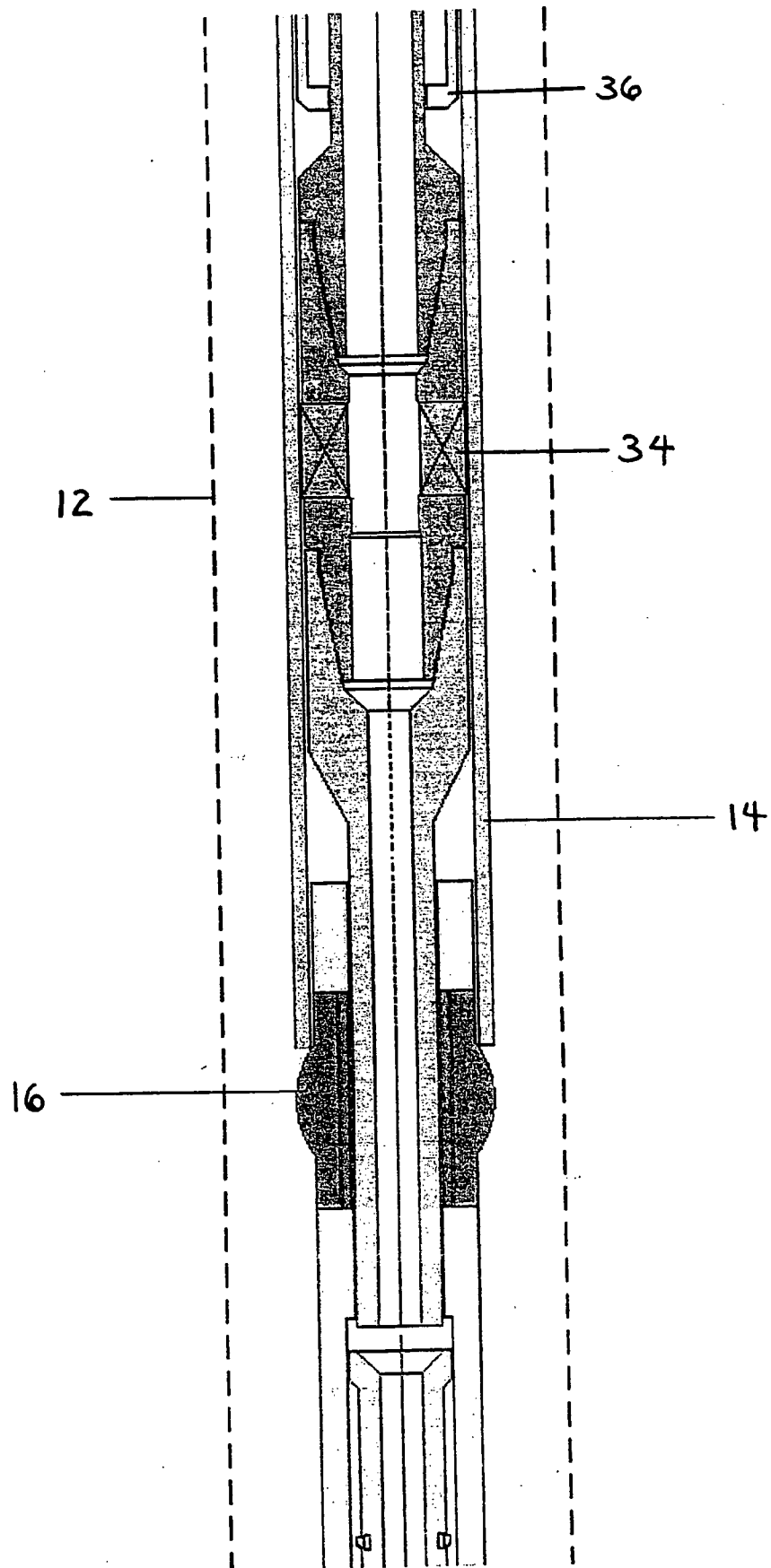

Fig. 8c

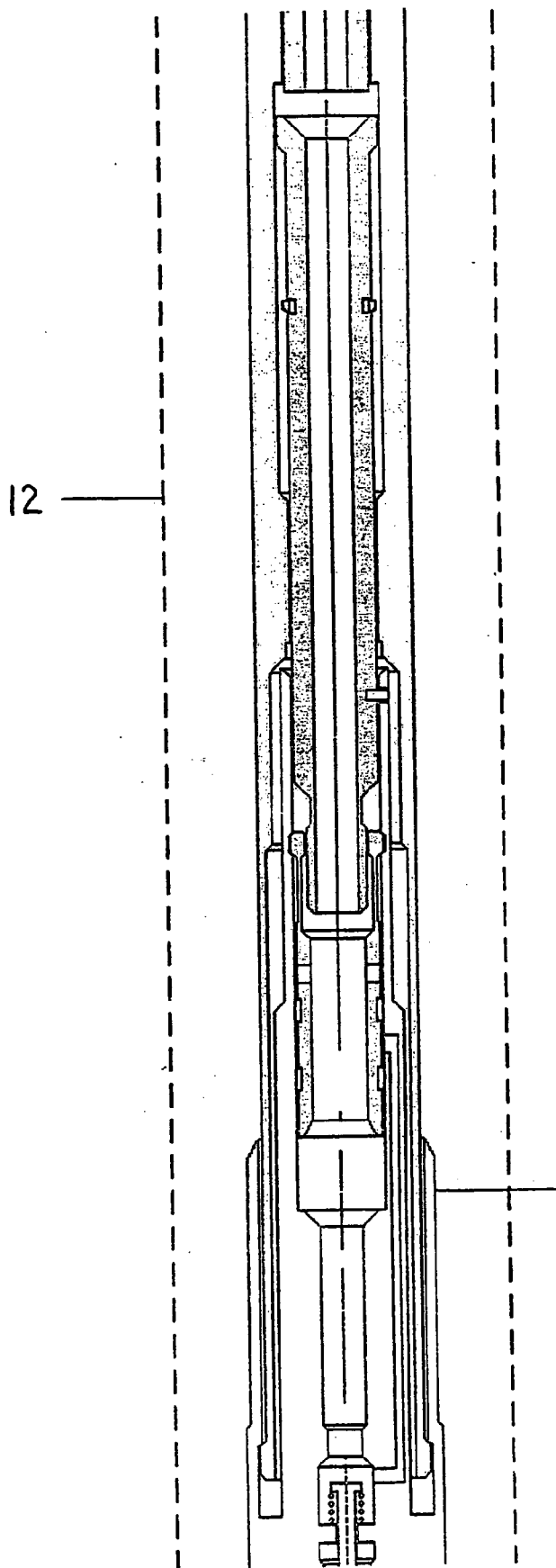

Fig. 8d

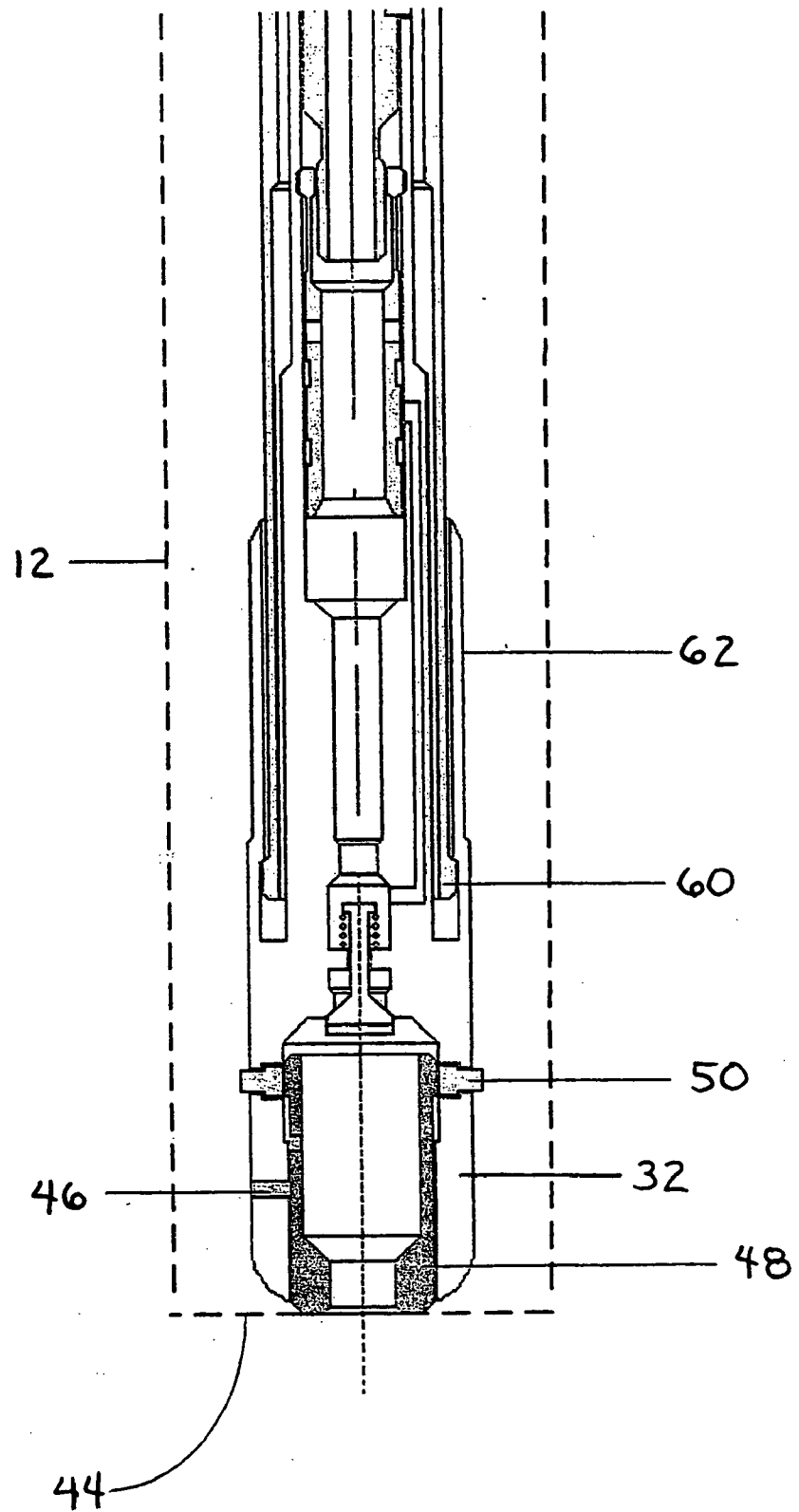

Fig. 8e



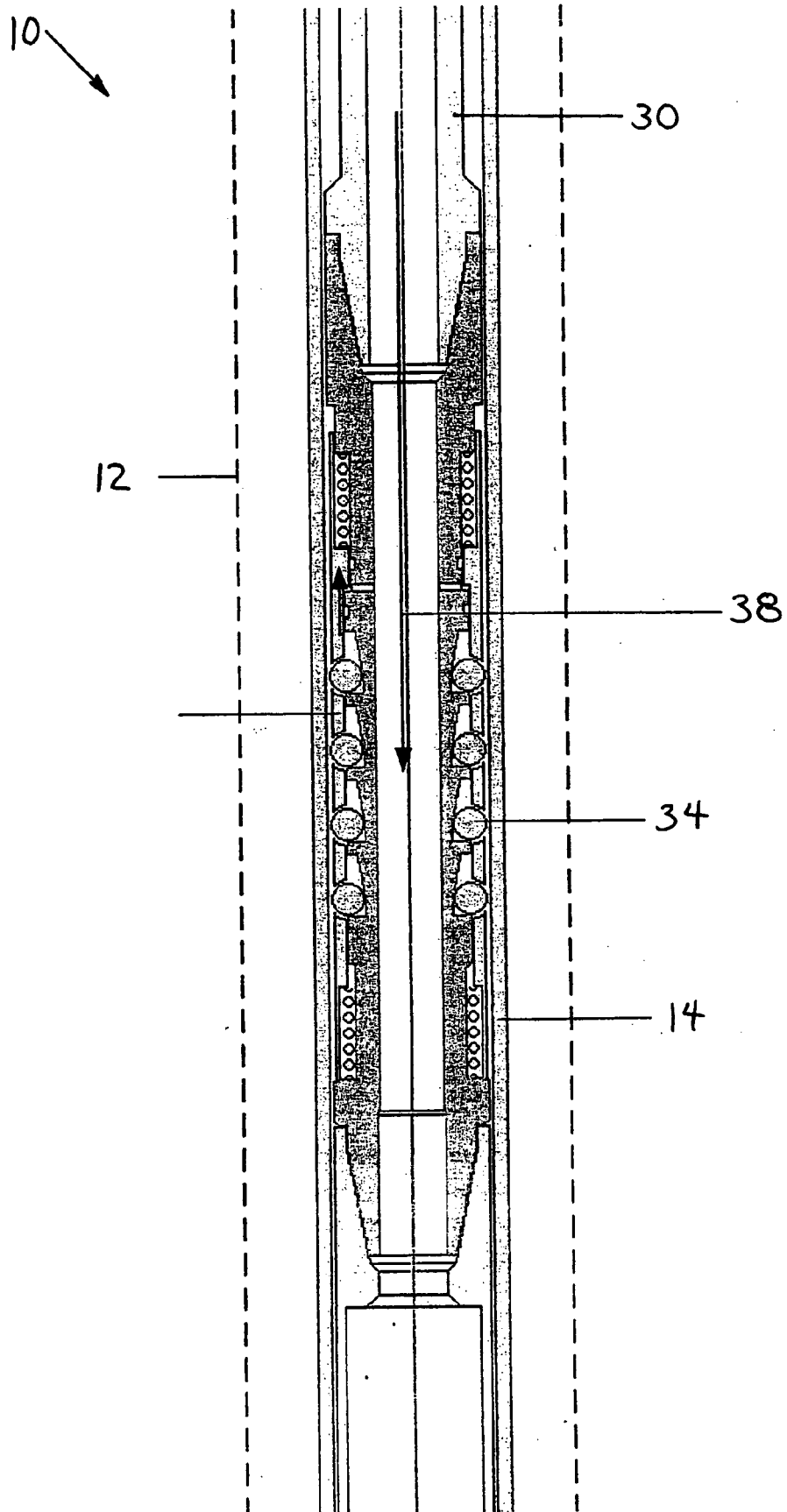

Fig. 9a

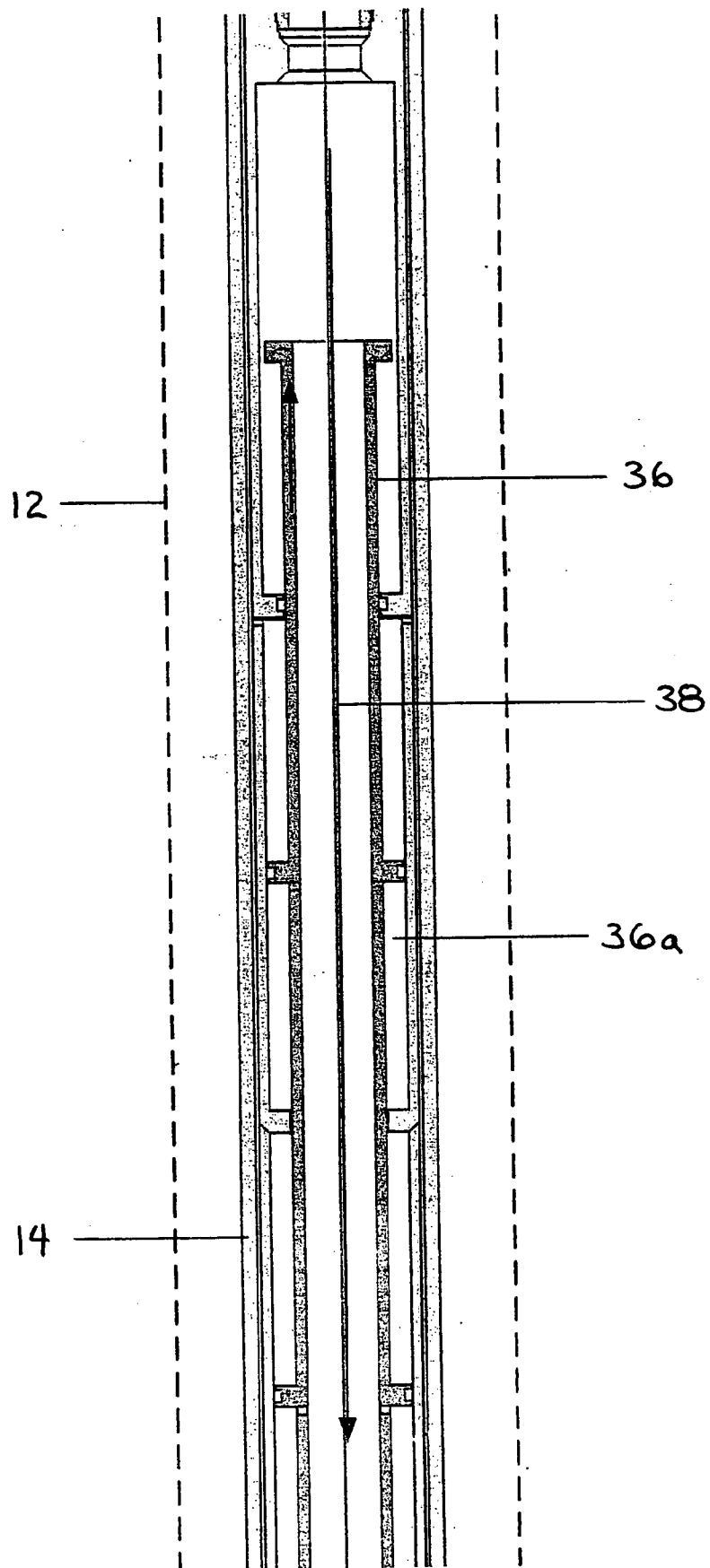

Fig. 9b

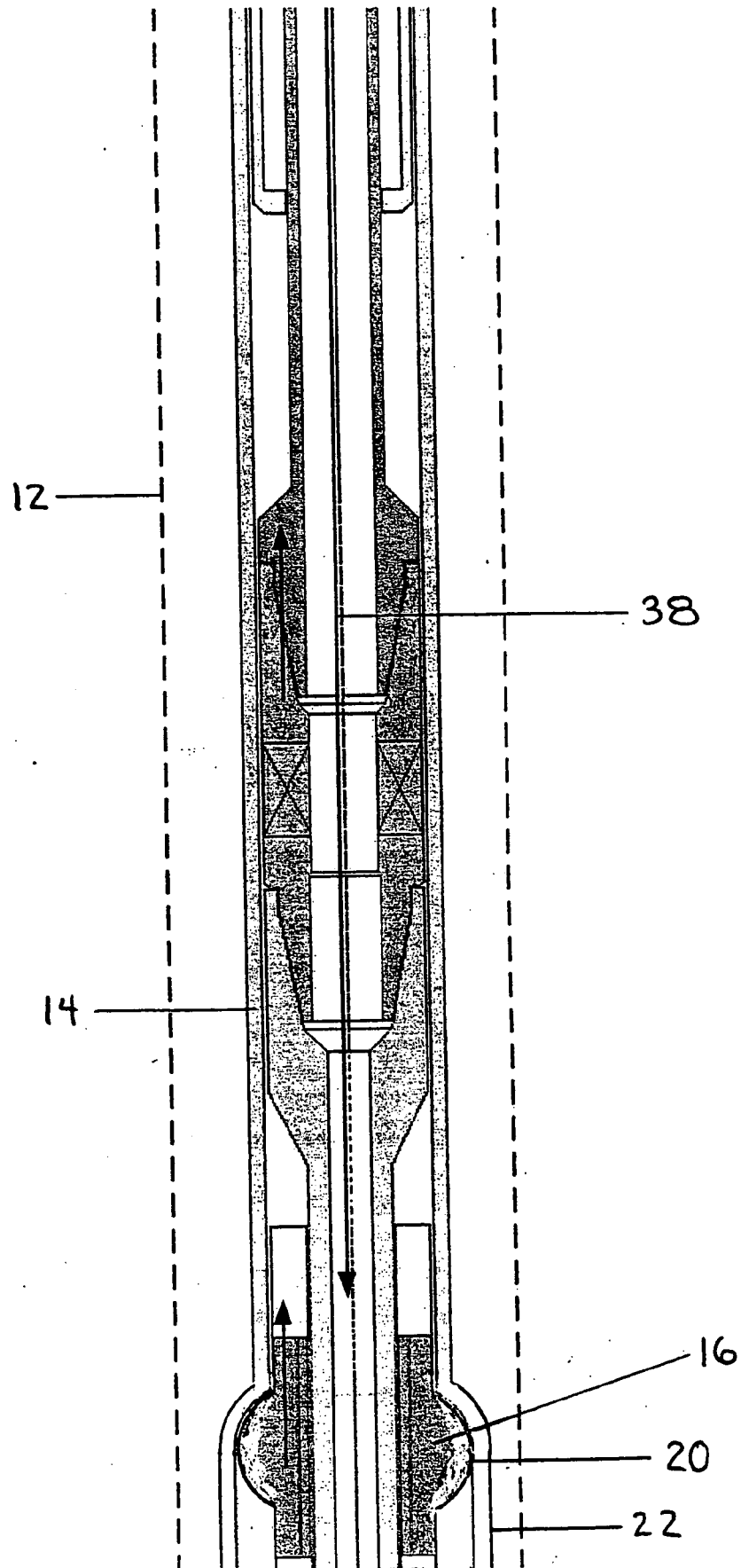

Fig. 9c

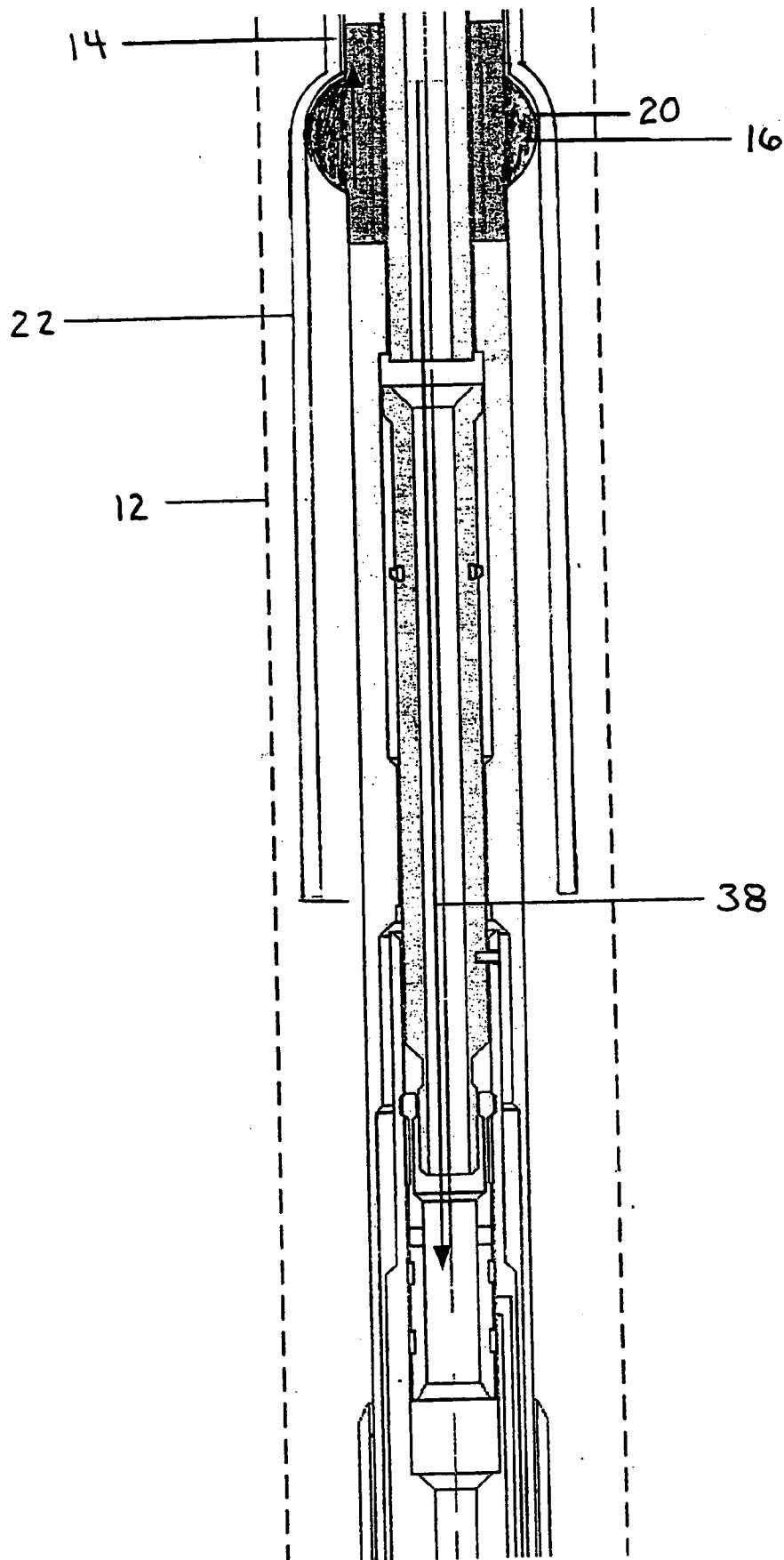
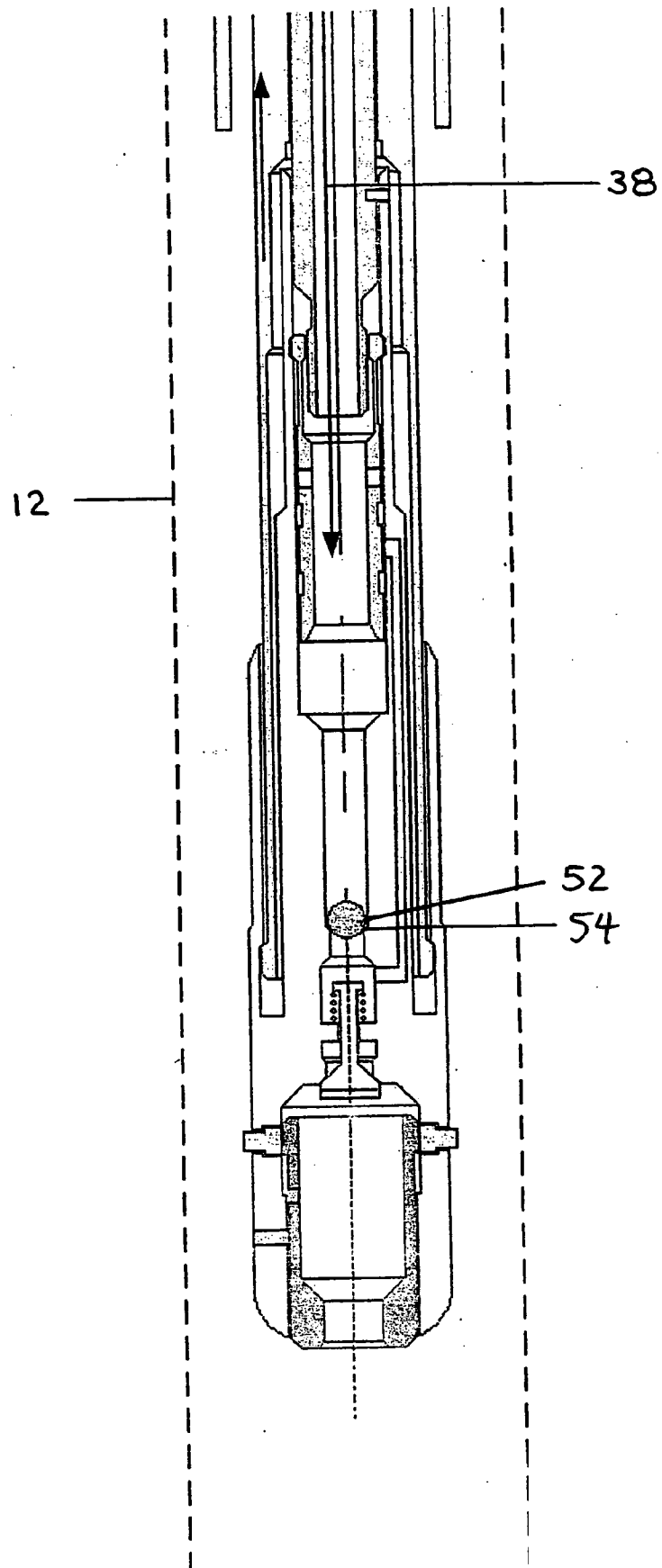

Fig. 9d



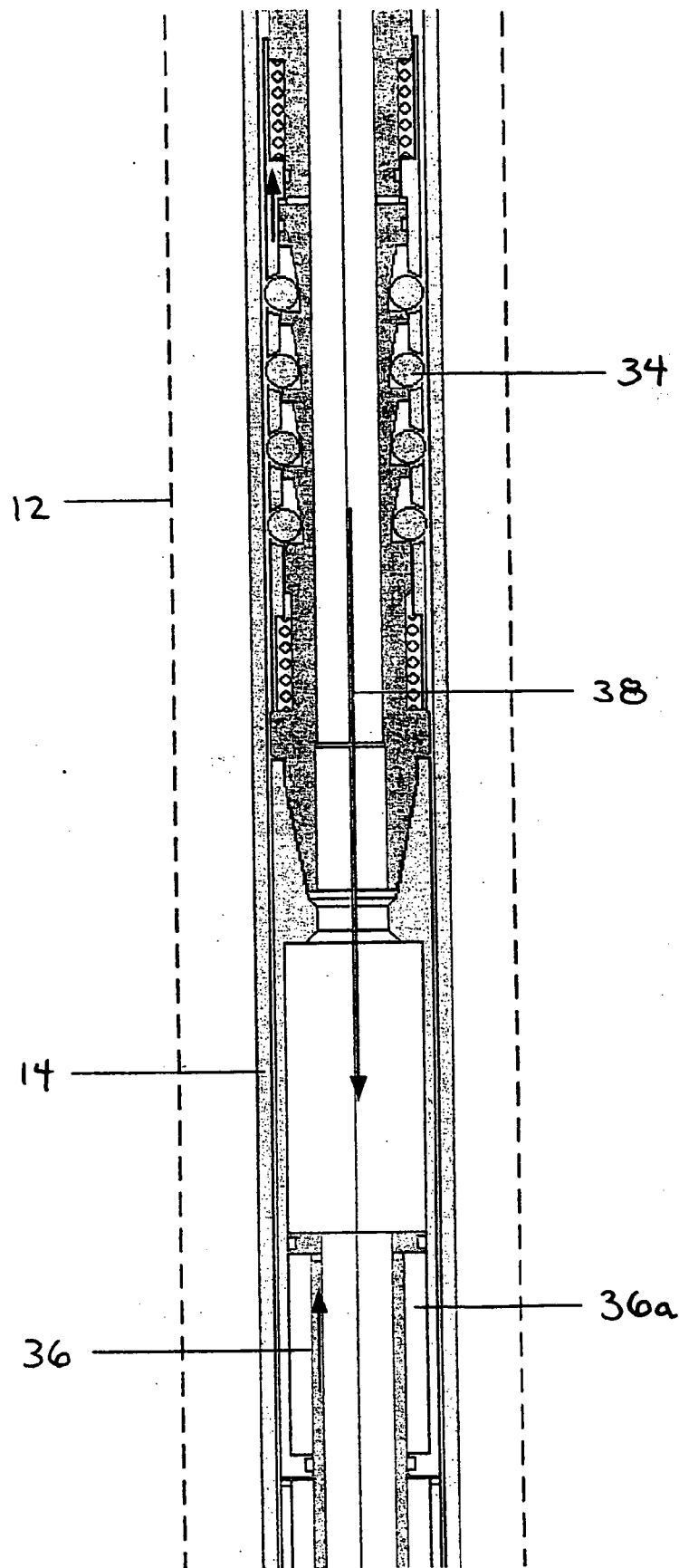

Fig. 10a

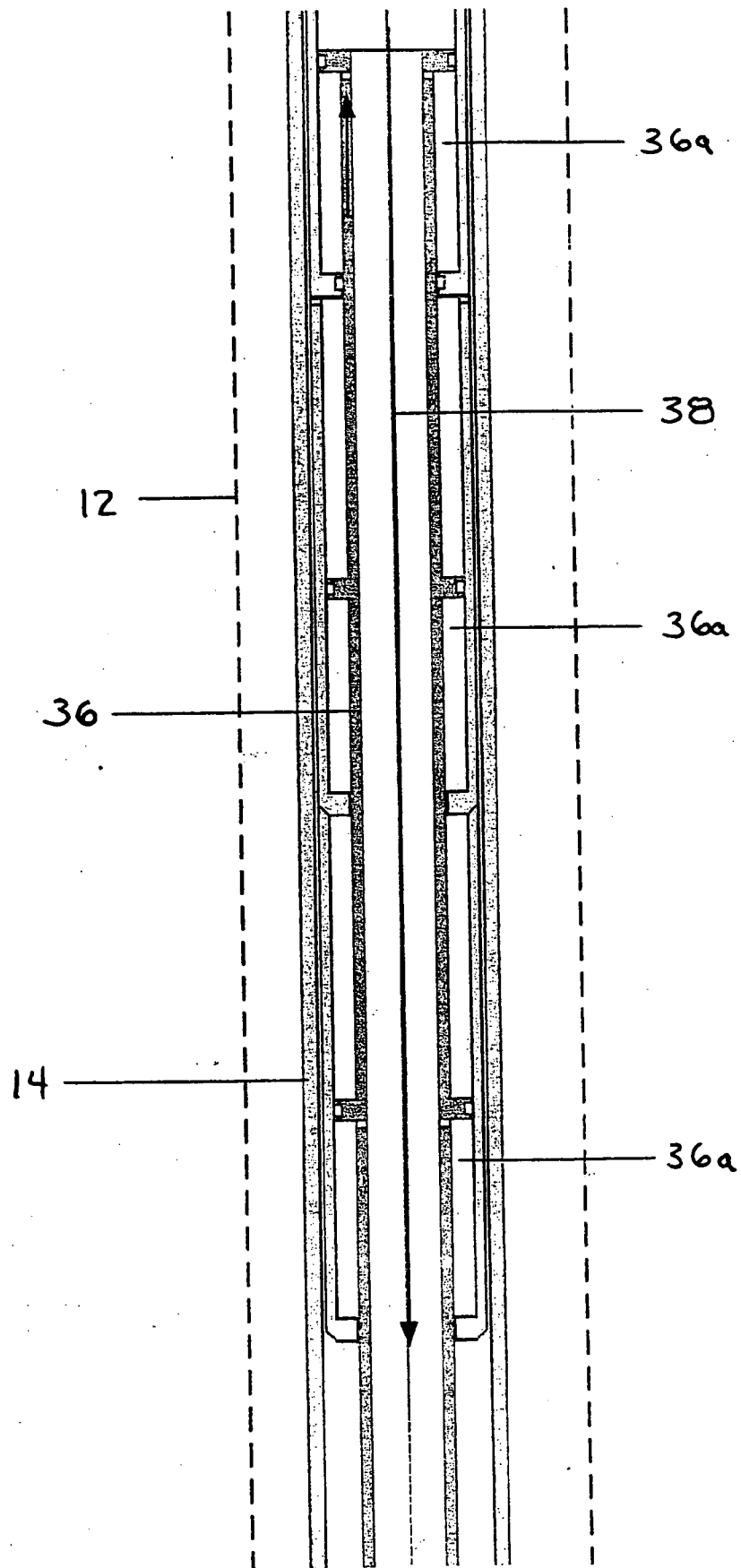

Fig. 10b

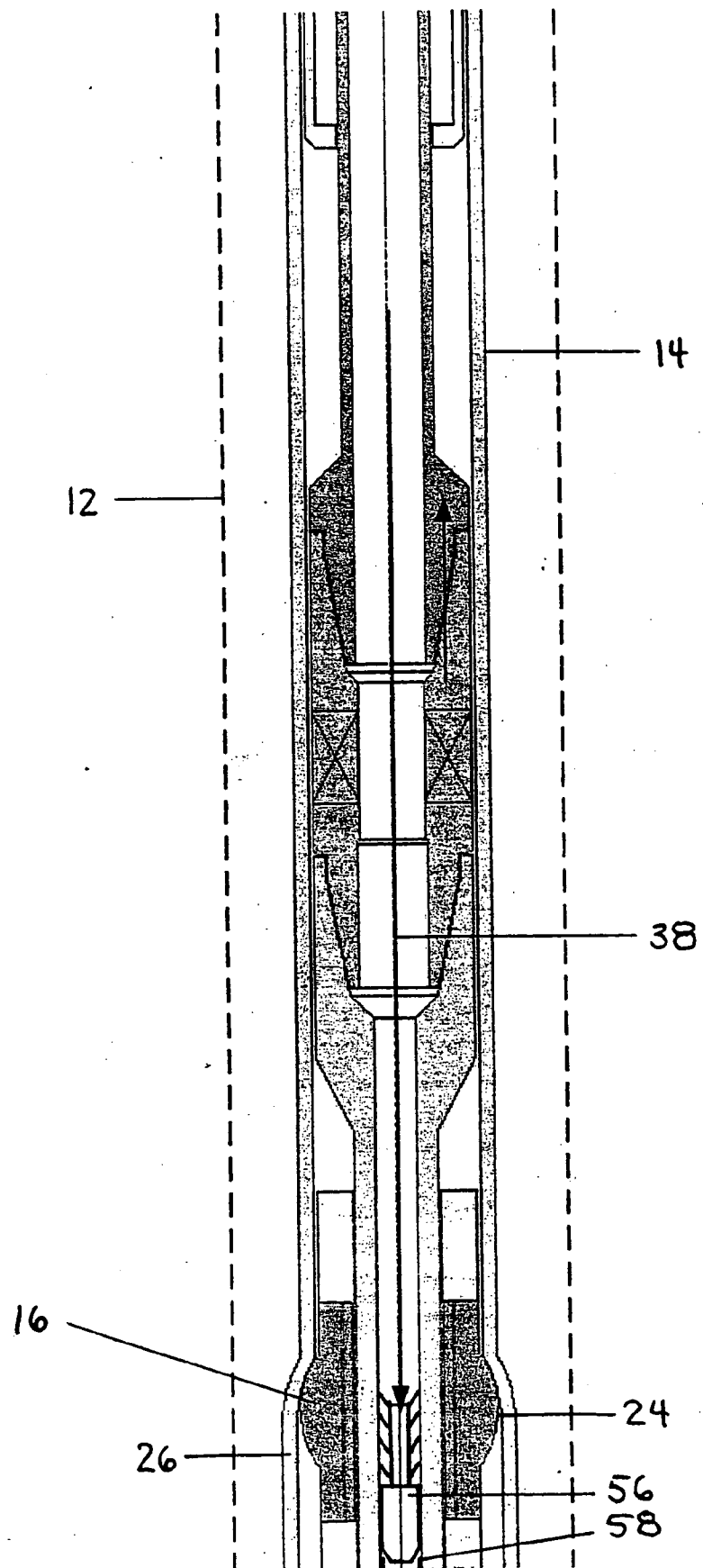

Fig. 10c



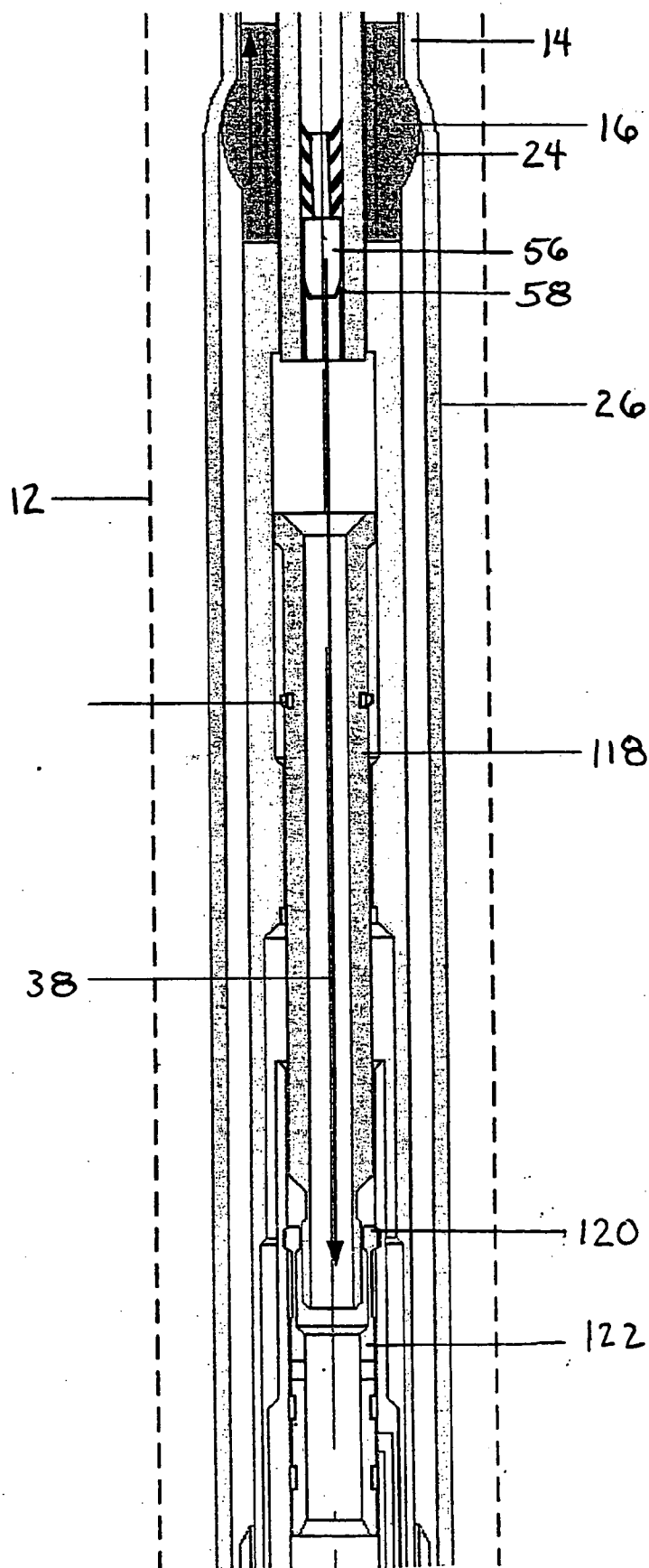

Fig. 10d

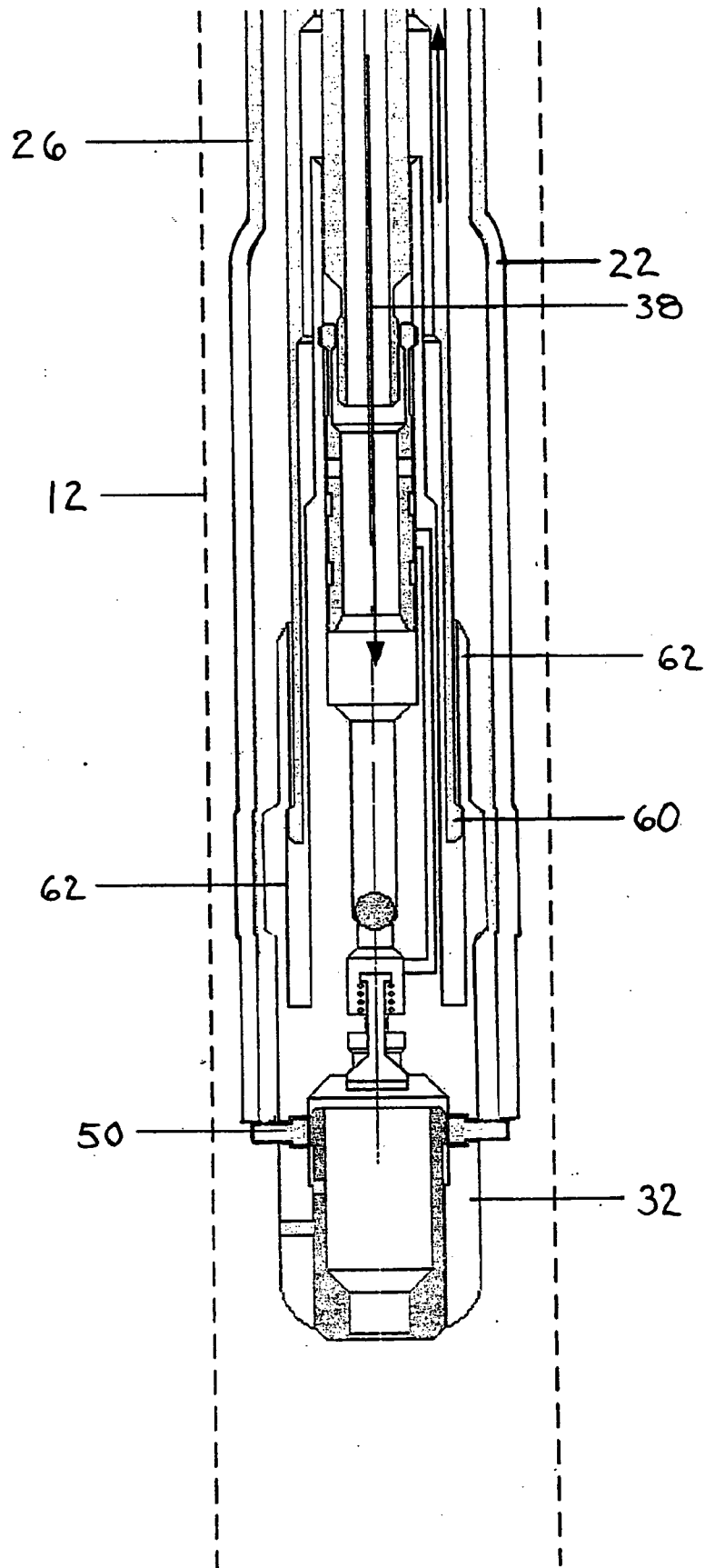

Fig. 10e

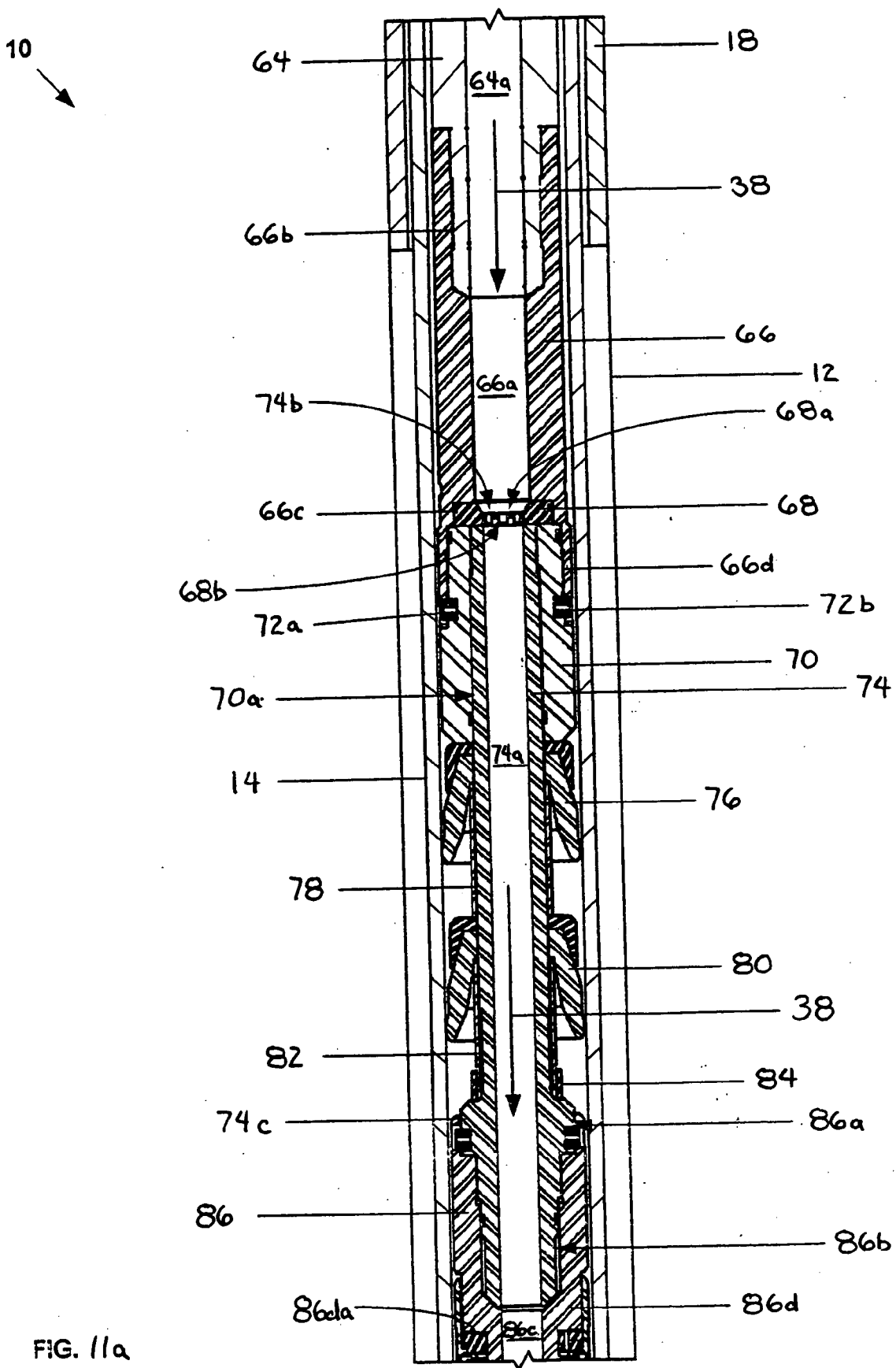

FIG. 11a

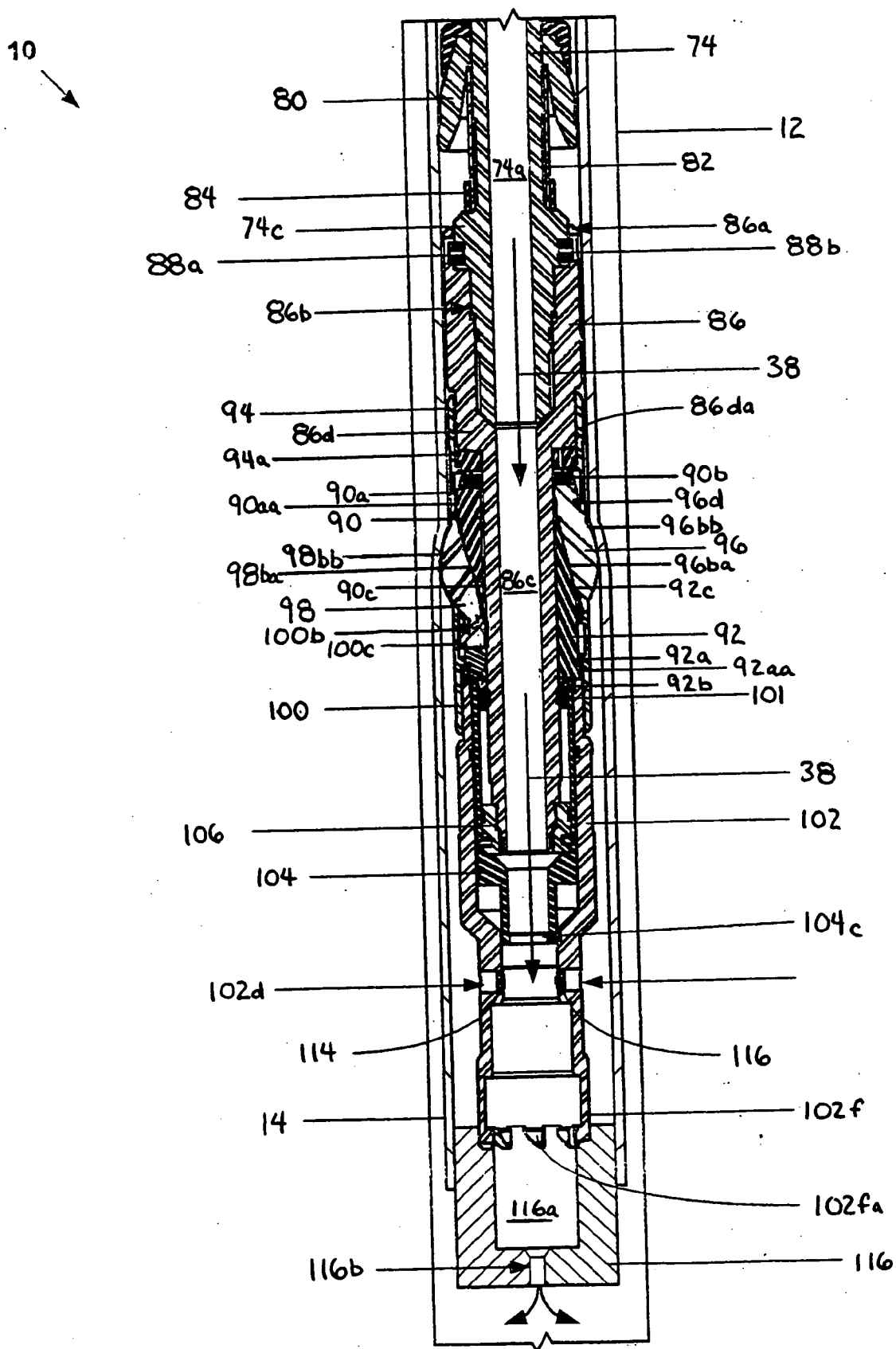

FIG. 11b

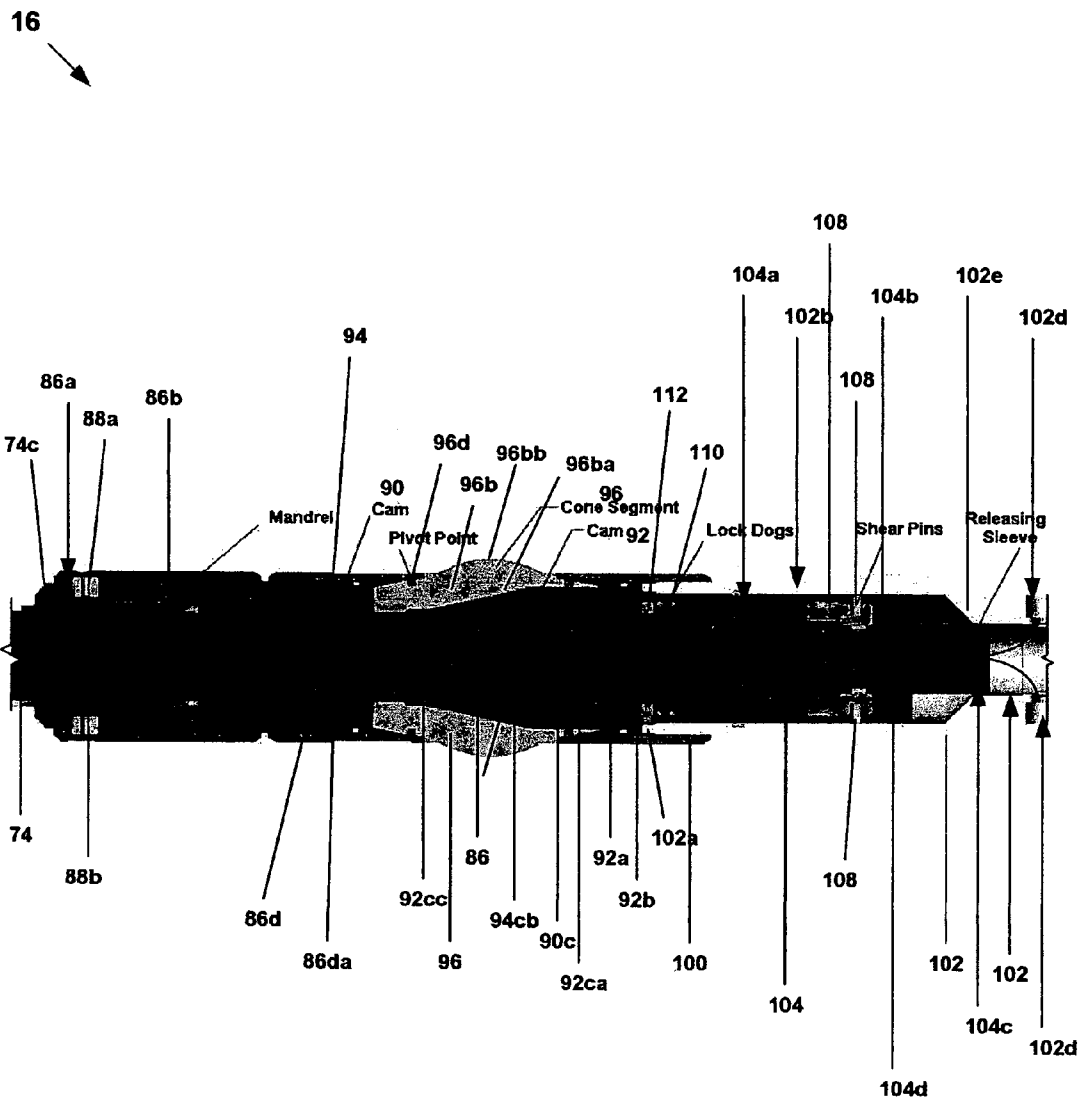

FIG. 12

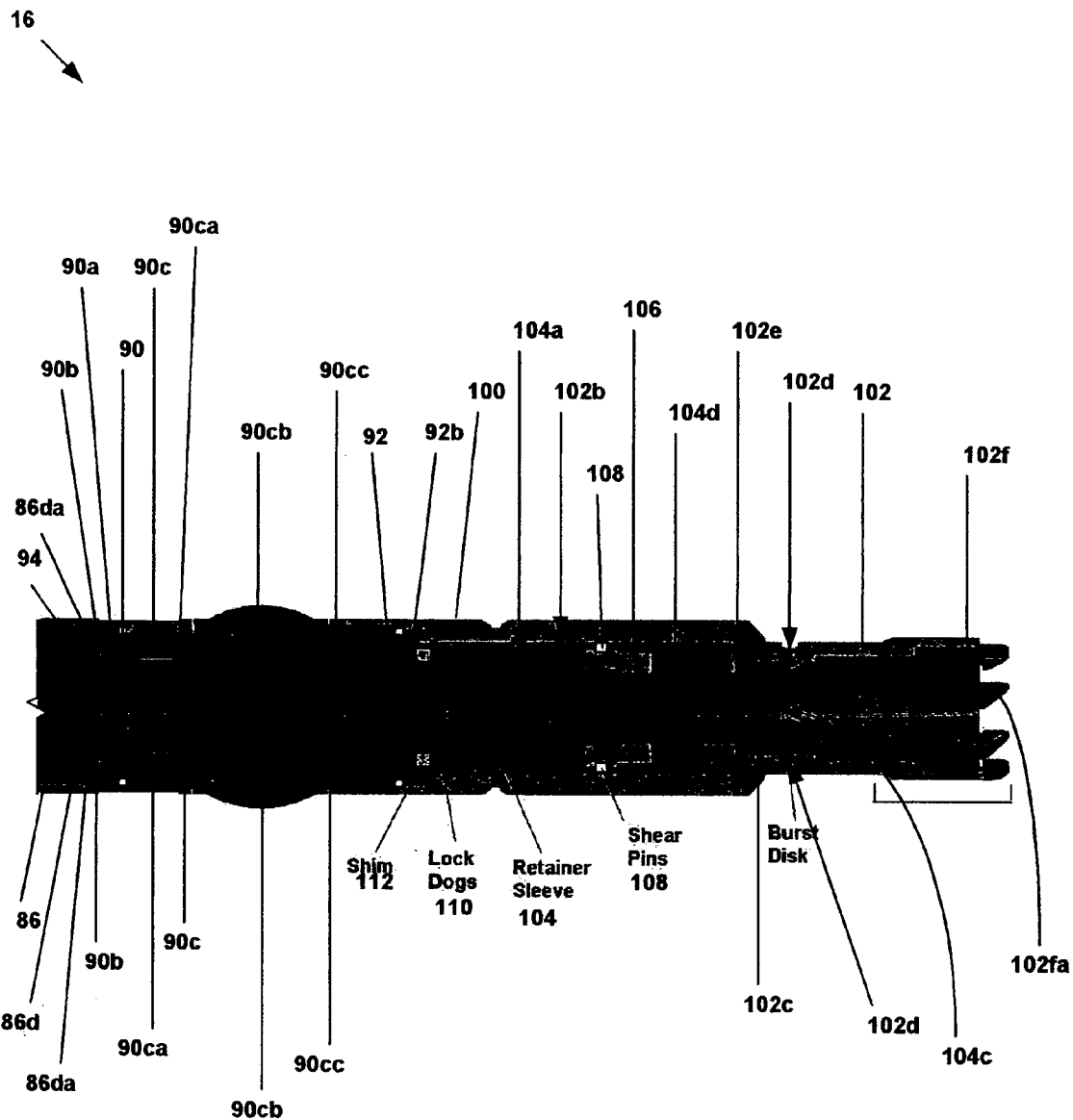

FIG. 13

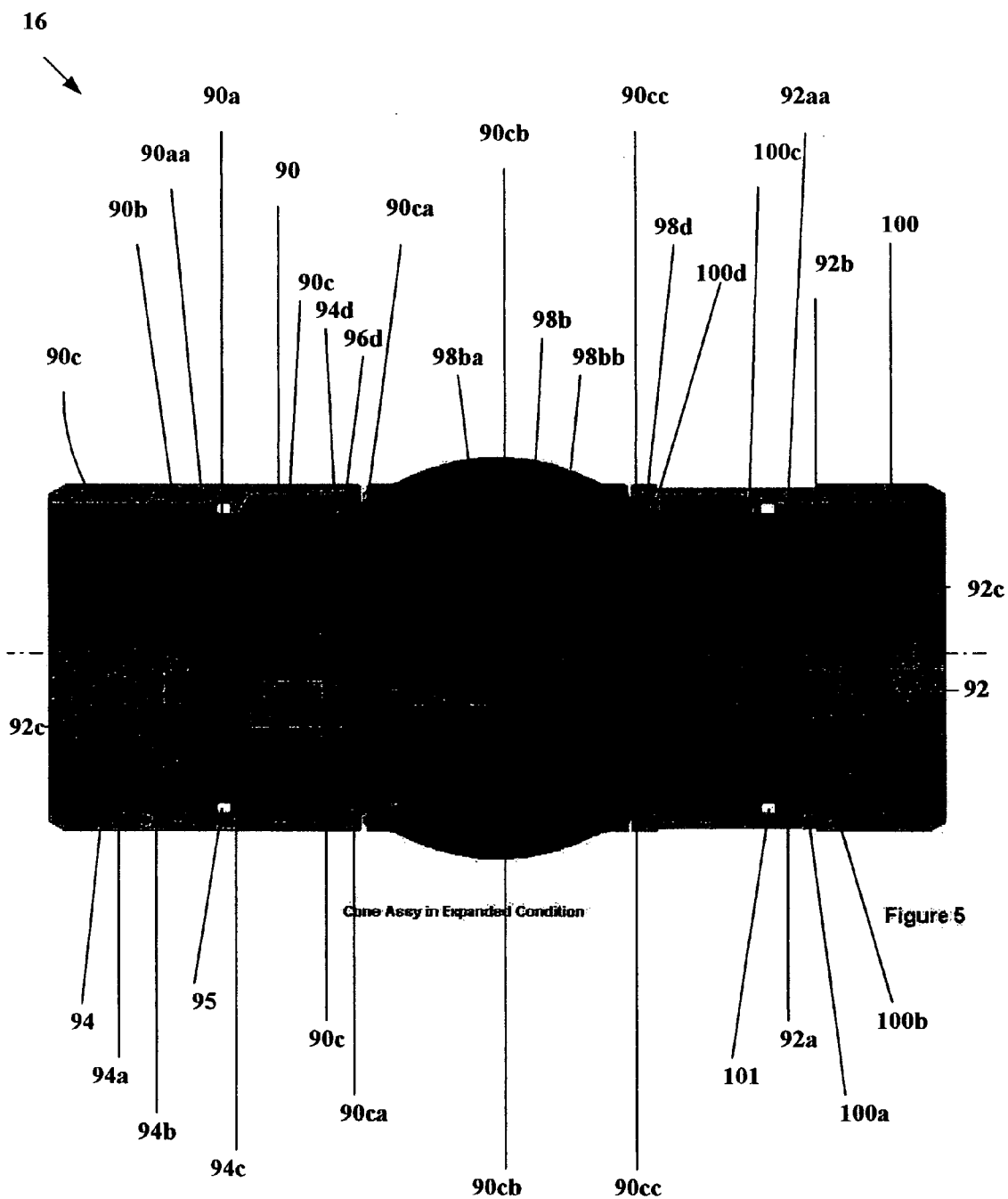

FIG. 14

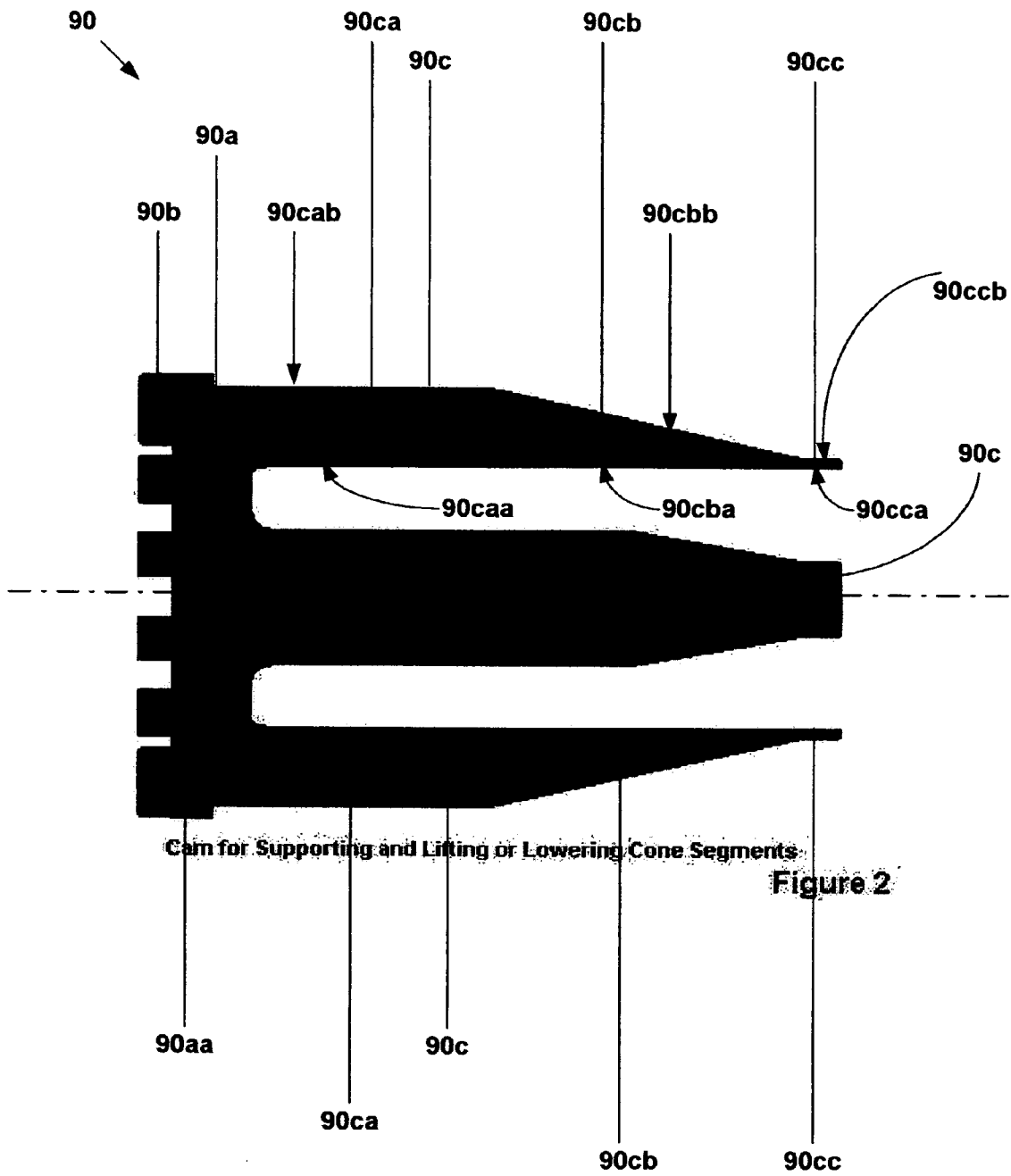

FIG. 15



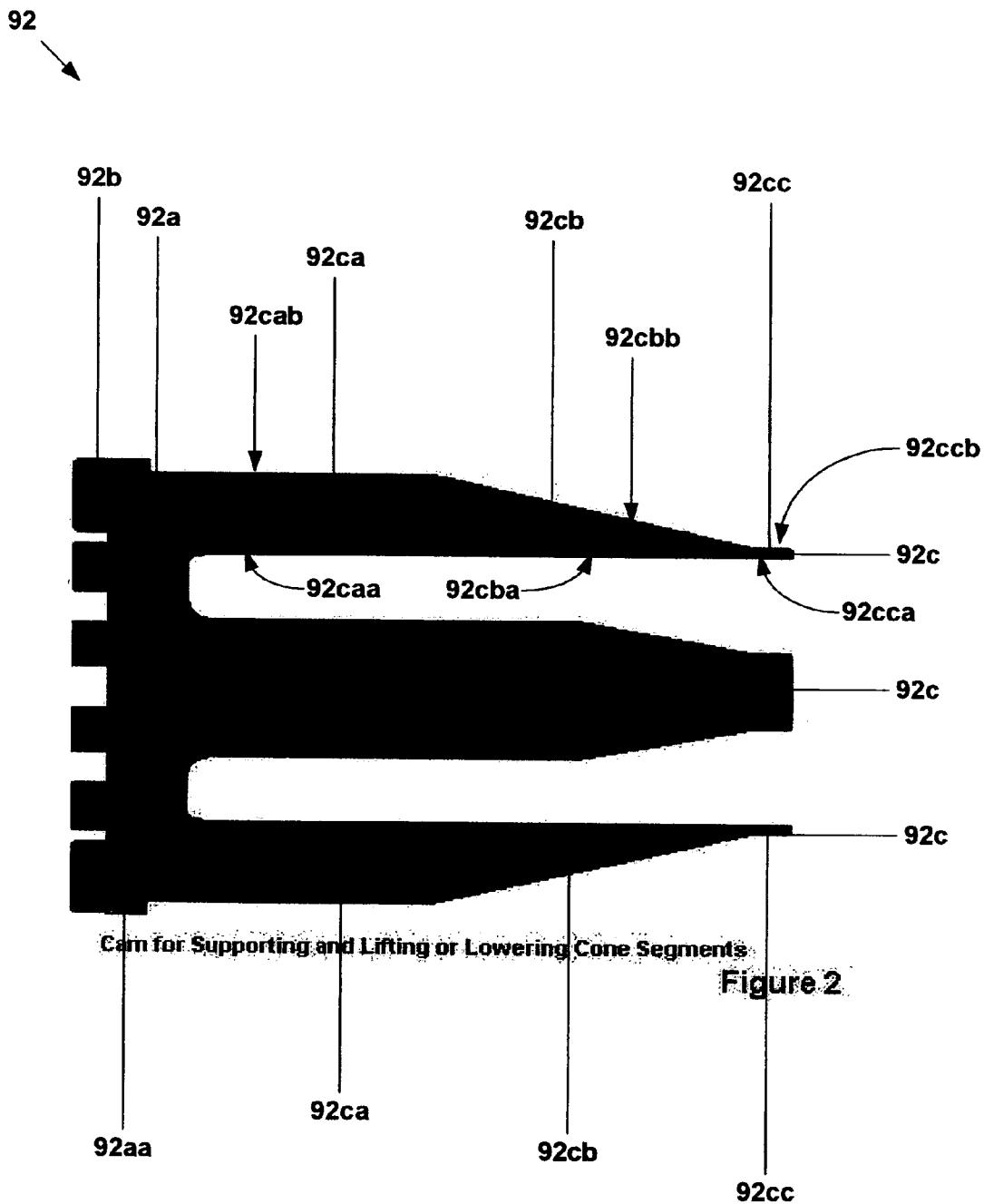

FIG. 16

10  
↙

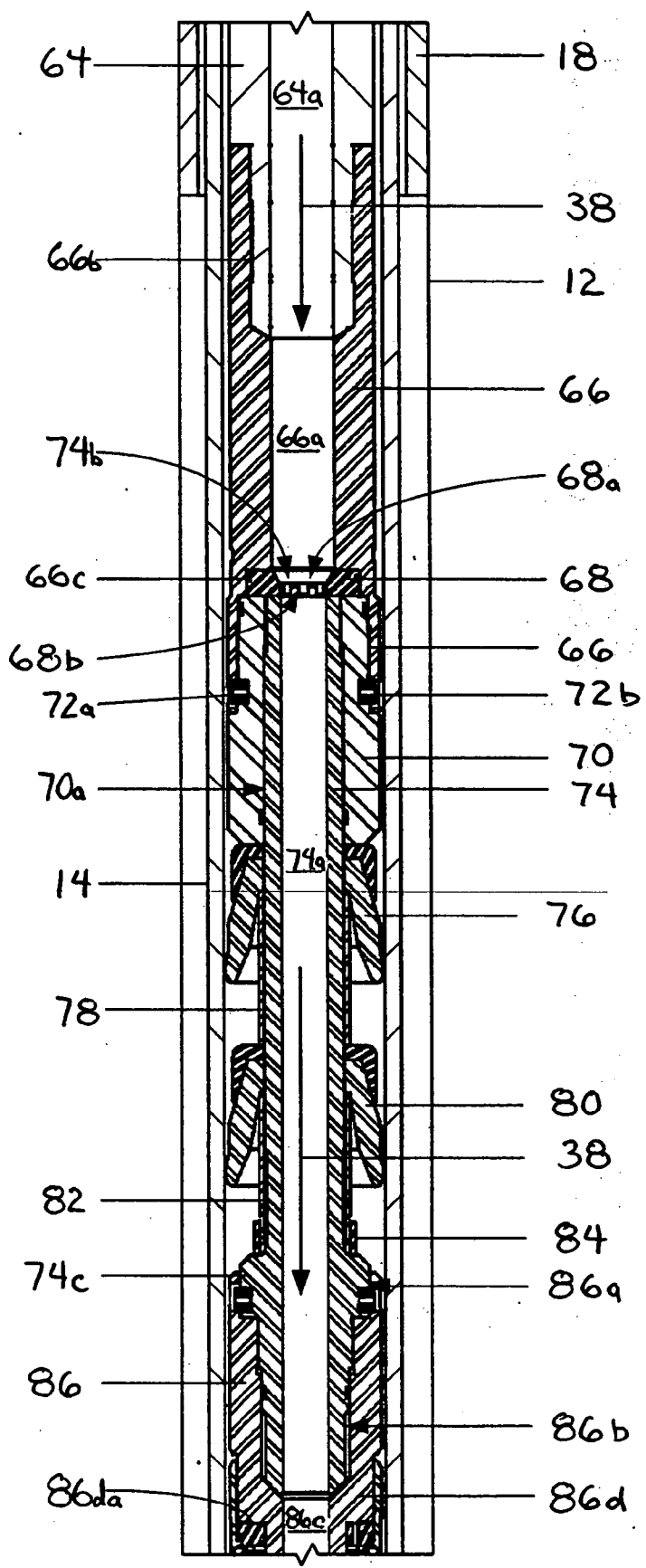

FIG. 17a

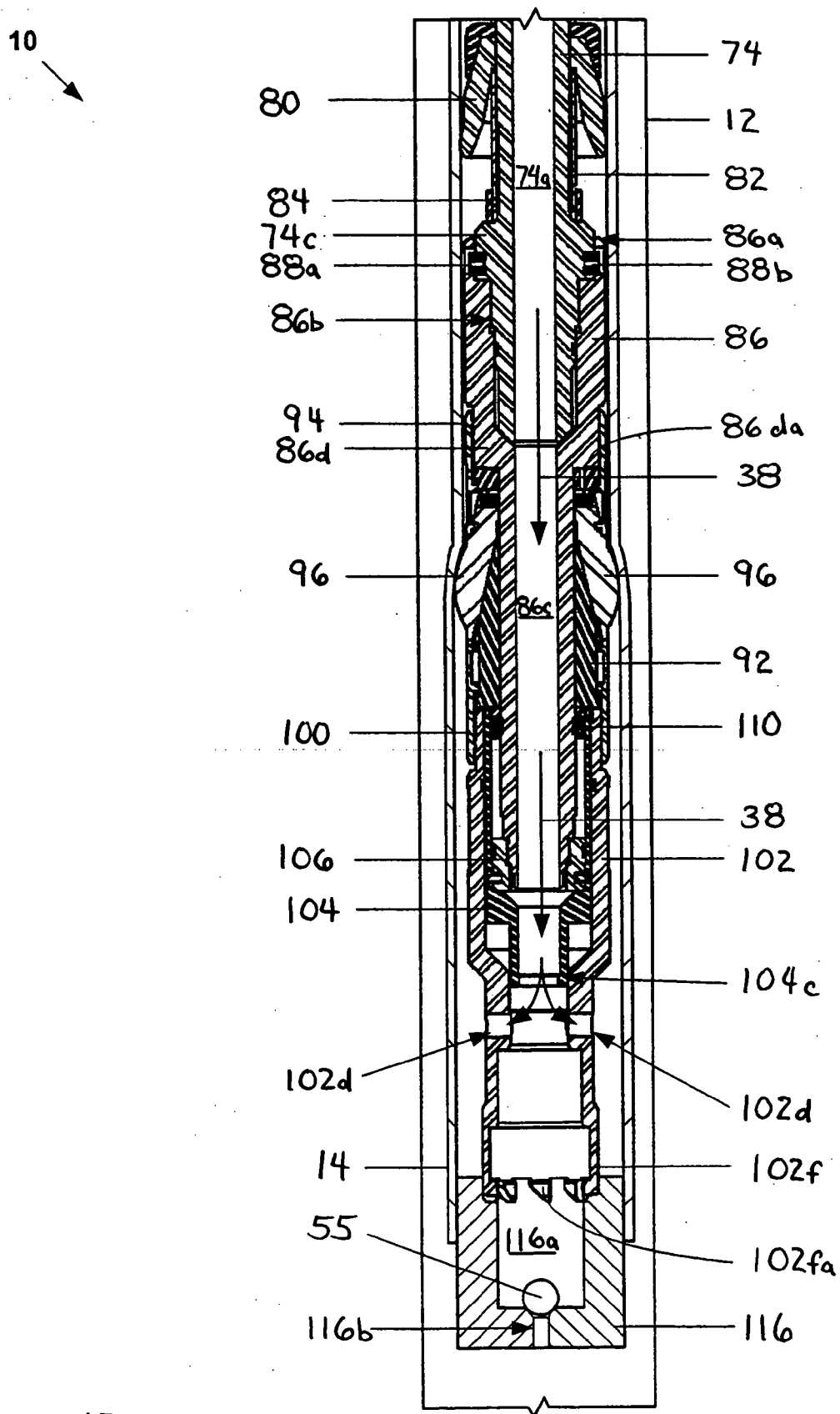

FIG. 17b

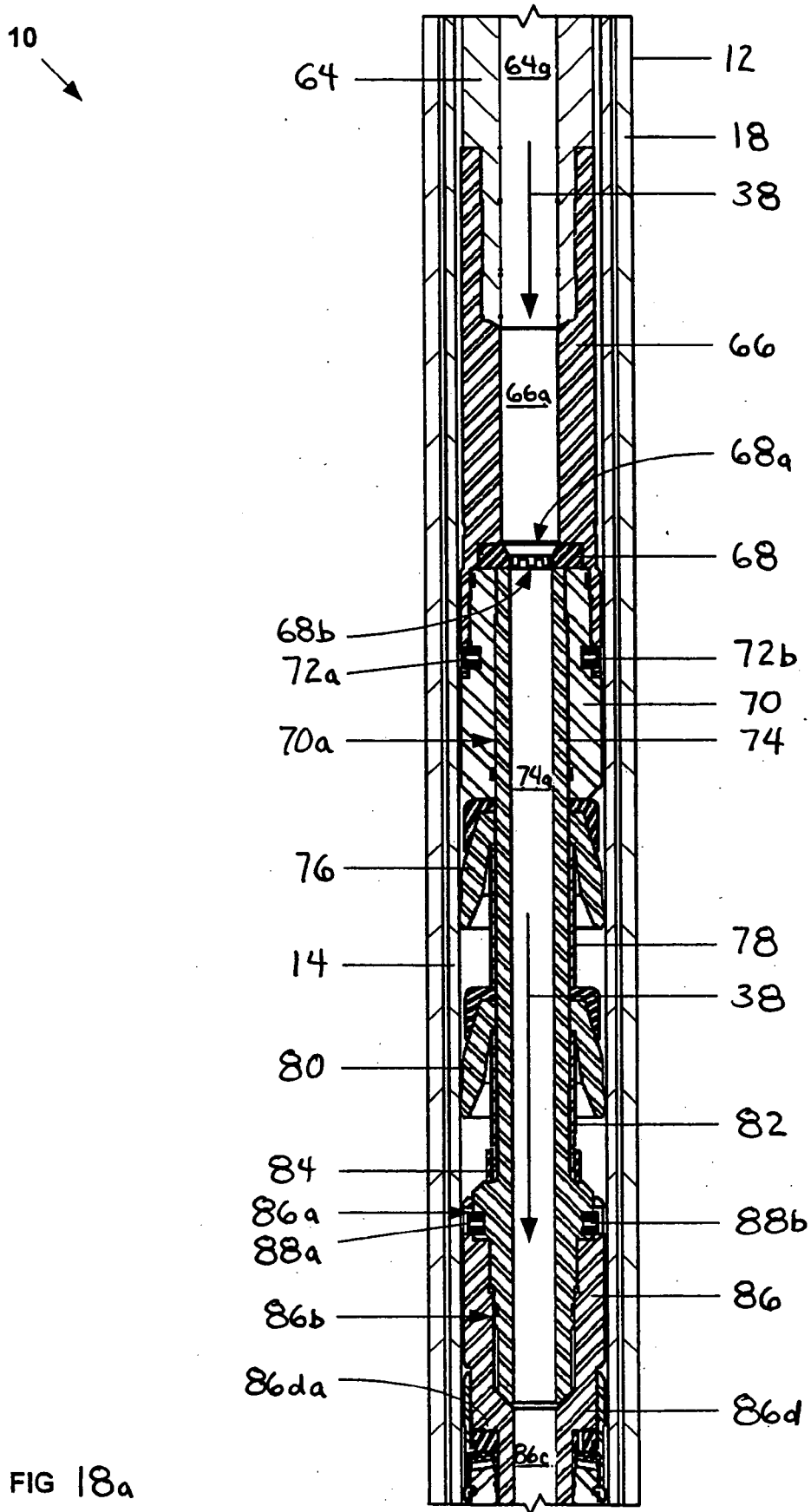
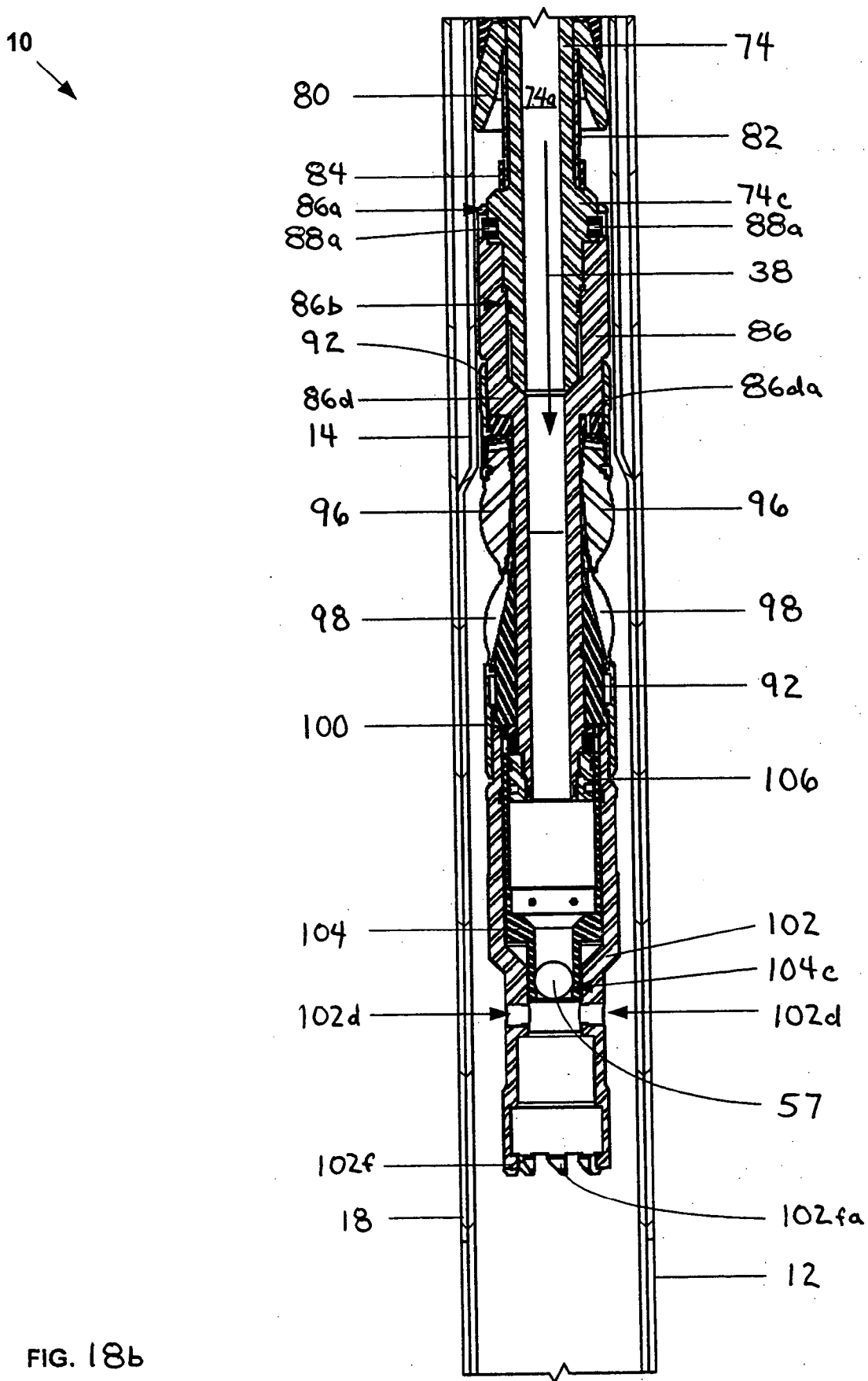

FIG 18a



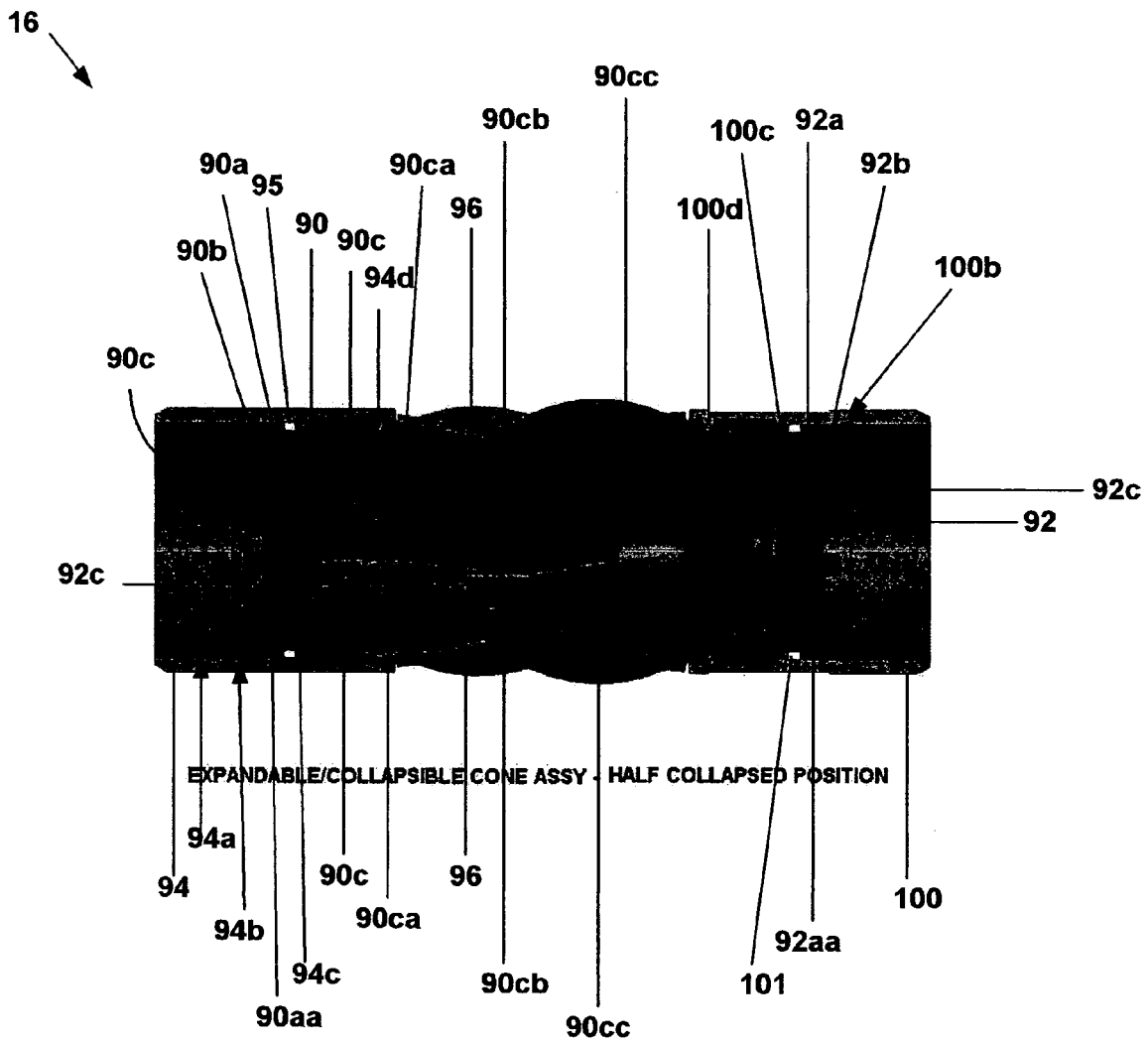

FIG. 19

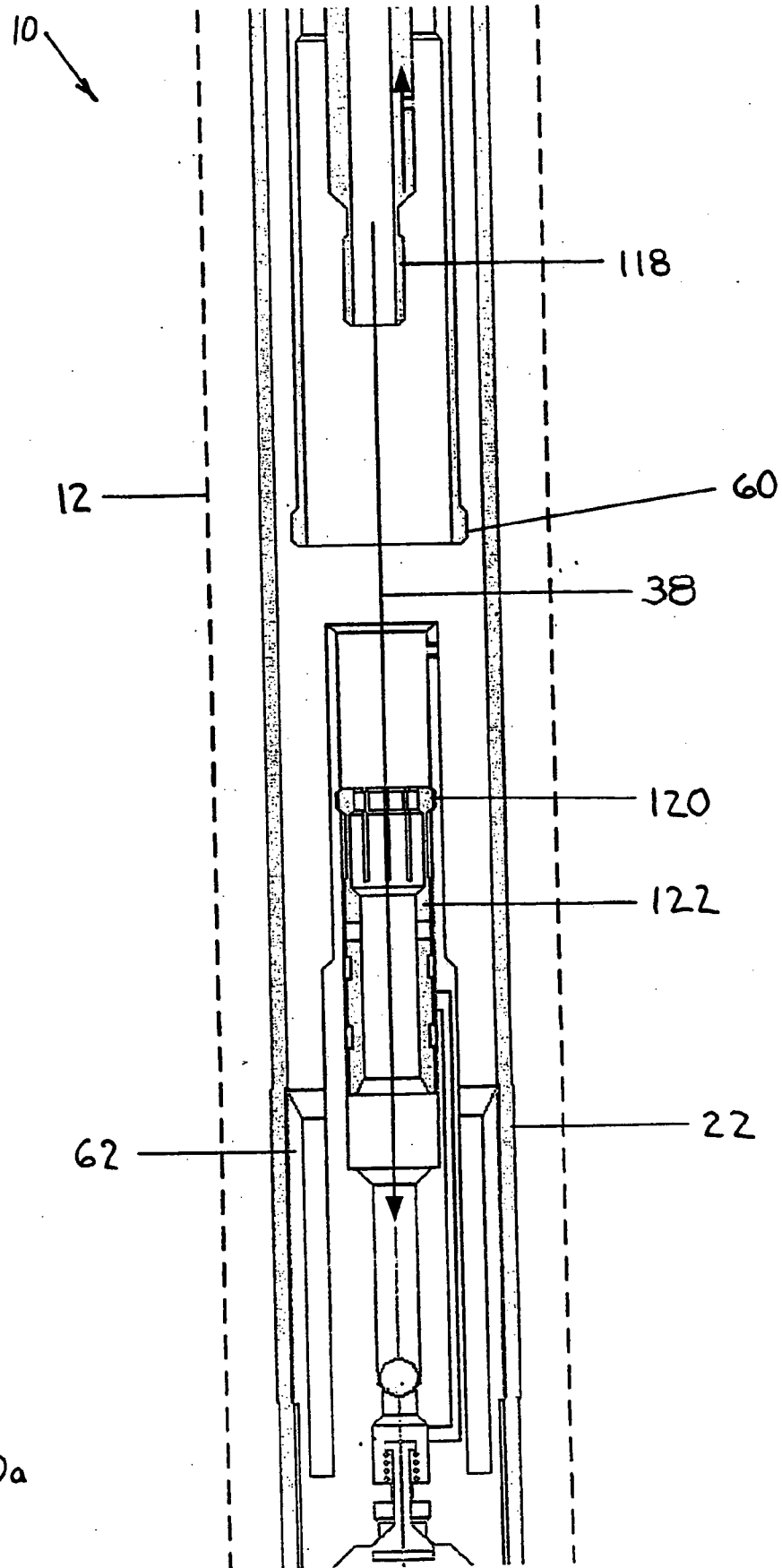

Fig. 20a

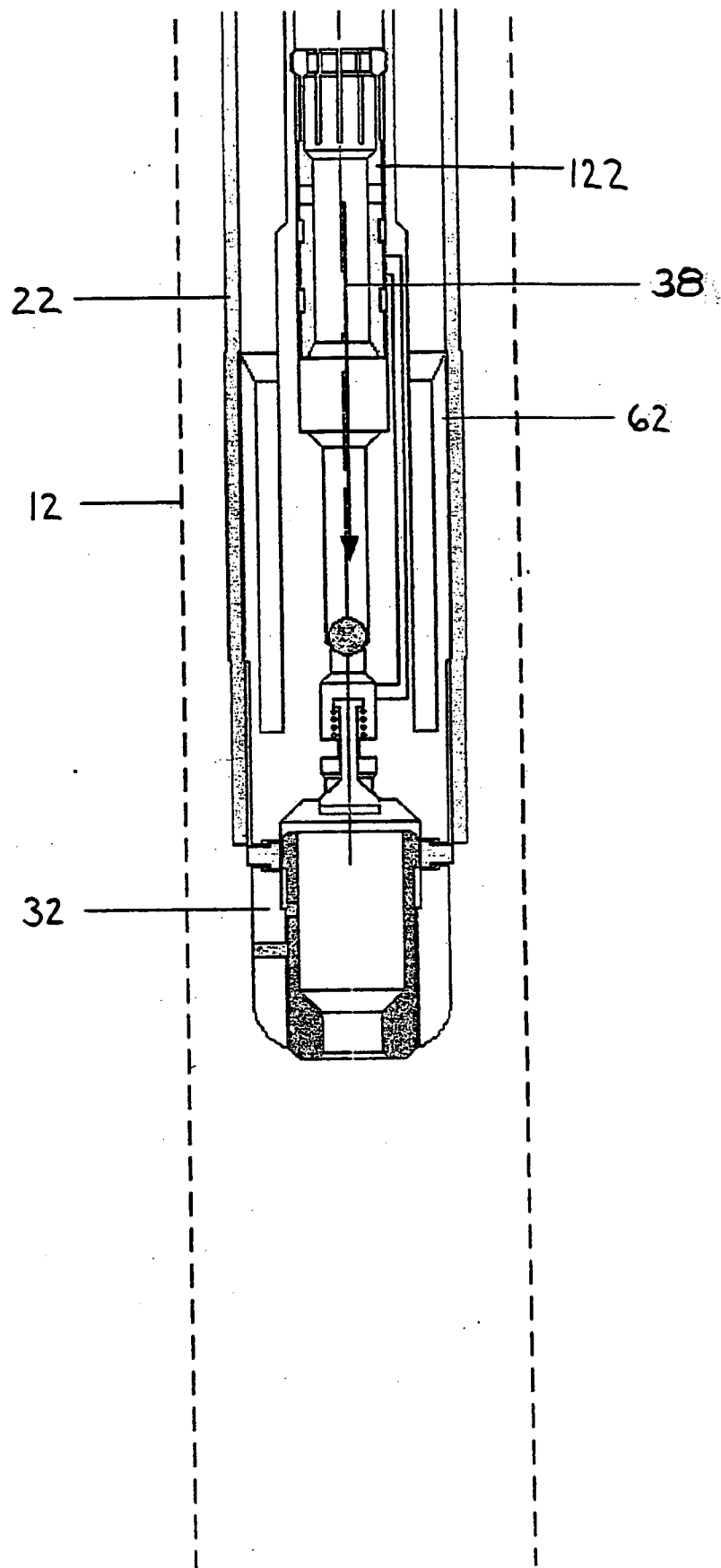

Fig. 20b



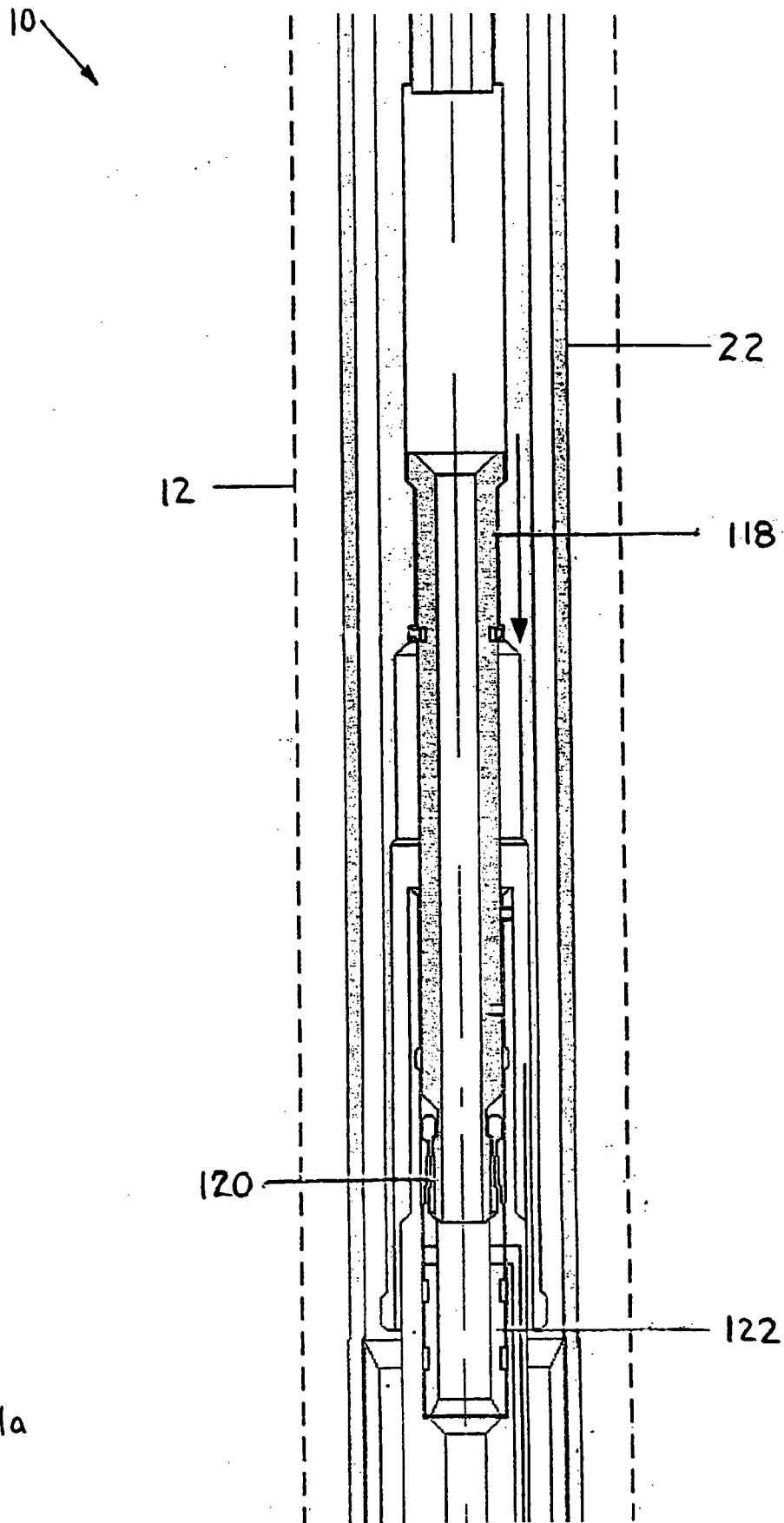

Fig. 21a

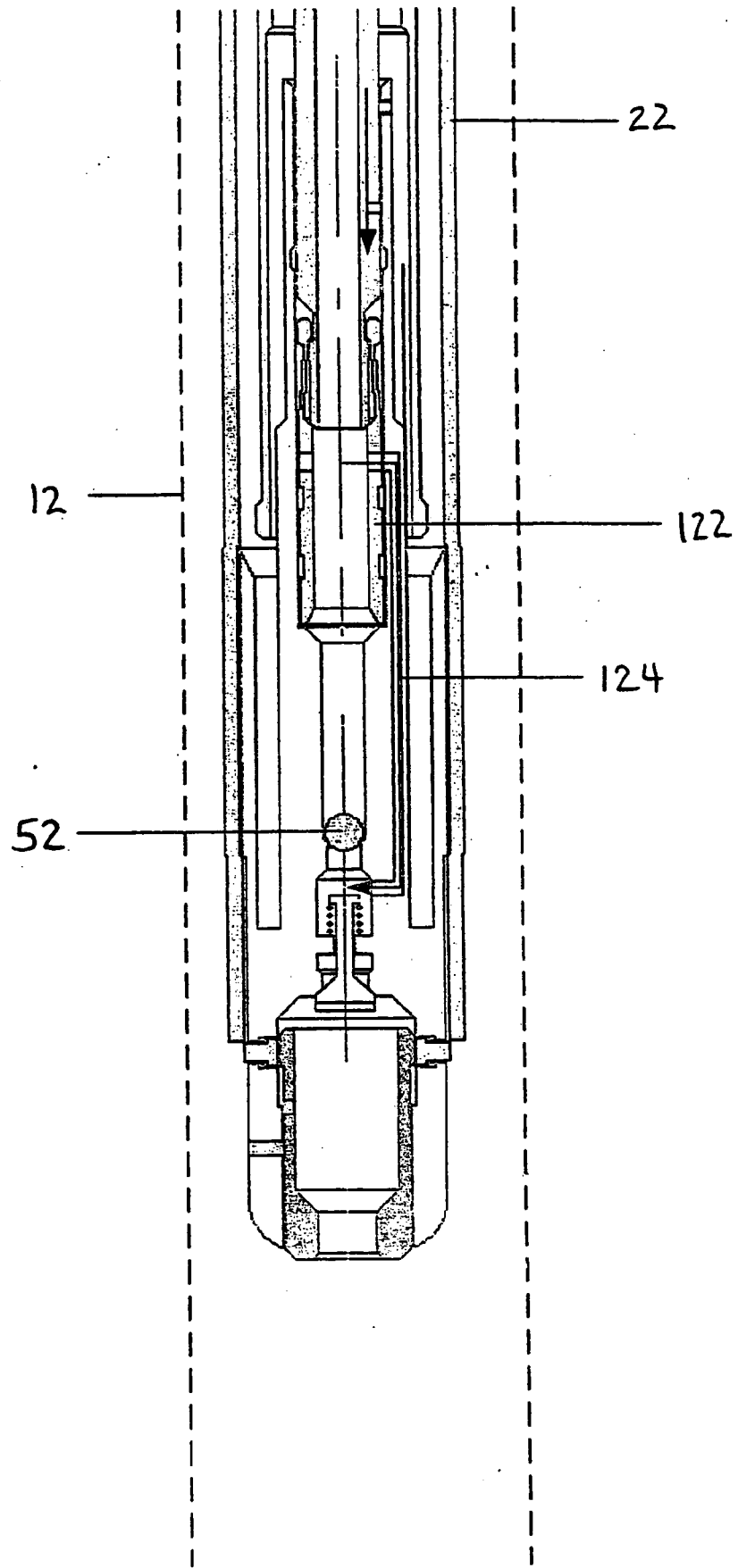

Fig. 21b

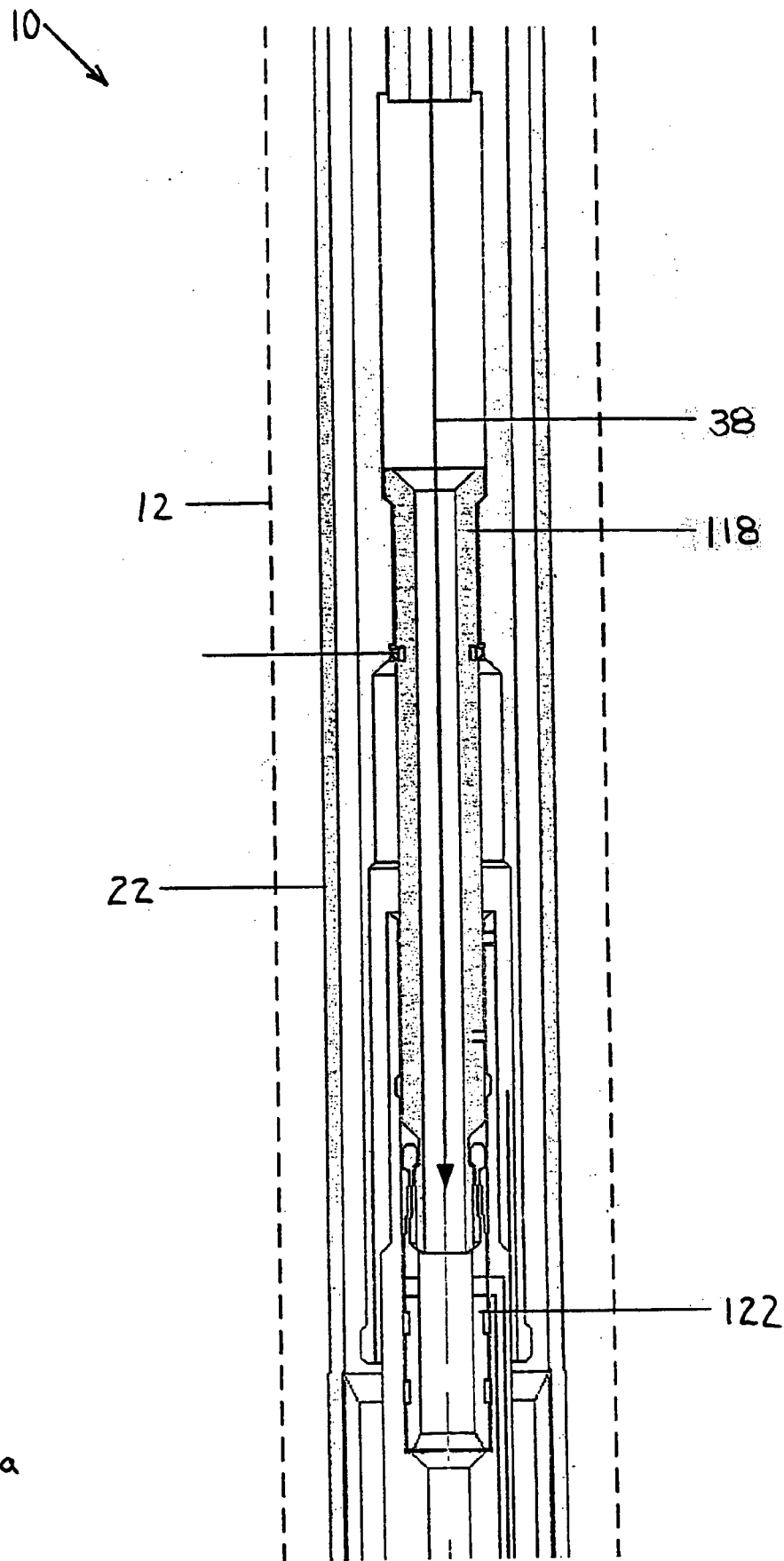

Fig. 22a

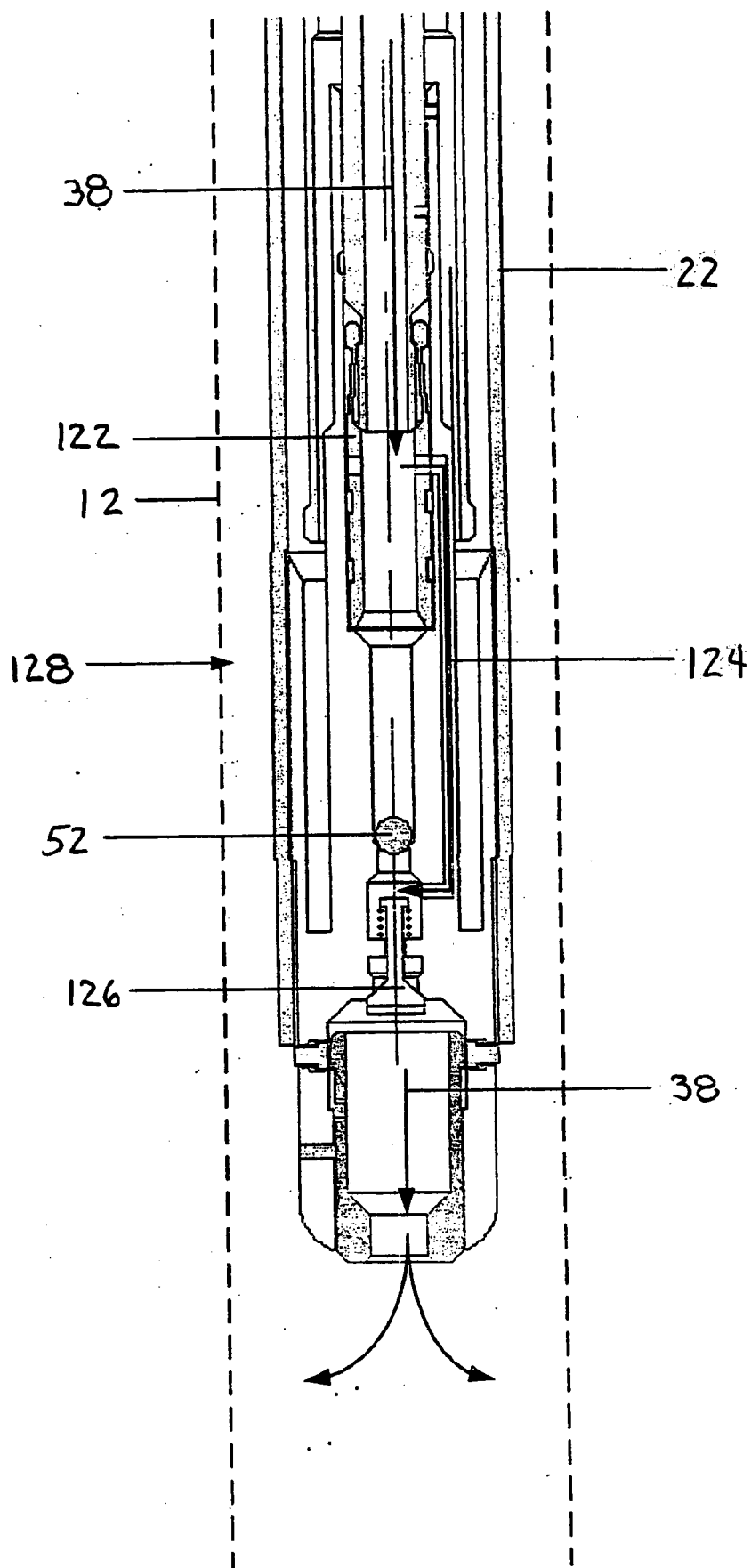

Fig. 22b

**MONO DIAMETER WELLBORE CASING****CROSS REFERENCE TO RELATED APPLICATIONS**

[0001] The present application is the National Stage patent application for PCT patent application serial number PCT/US2003/029859, attorney docket number 25791.102.02, filed on Sep. 22, 2003, which claimed the benefit of the filing dates of (1) U.S. provisional patent application Ser. No. 60/412,542, attorney docket no 25791.102, filed on Sep. 20, 2002, the disclosures of which are incorporated herein by reference.

[0002] The present application is a continuation in part of U.S. utility patent application Ser. No. 10/513,614, attorney docket number 25791.104.02, filed on Nov. 5, 2004, which was the National Stage application for PCT application serial number PCT/US2003/014153, attorney docket number 25791.104, filed on Nov. 13, 2003, which claimed the benefit of U.S. provisional patent application Ser. No. 60/380,147, attorney docket number 25791.104, filed on May 6, 2002, which was a continuation-in-part of U.S. utility patent application Ser. No. 10/507567, attorney docket number 25791.95.03, filed on Sep. 13, 2004, which was the National Stage application for PCT application serial number PCT/US2003/004837, attorney docket number 25791.95.02, filed on Feb. 19, 2003, which claimed the benefit of the filing date of U.S. provisional patent application Ser. No. 60/363829, attorney docket number 25791.95, filed on Mar. 13, 2002, which was a continuation-in-part of both of: (1) U.S. utility patent application Ser. No. 10/495347, attorney docket number 25791.87.05, filed on May 12, 2004, which was filed as the National Stage application for PCT application serial number PCT/US2002/036157, attorney docket number 25791.87.02, filed on Nov. 12, 2002, which claimed the benefit of the filing date of U.S. provisional application Ser. No. 60/338996, attorney docket number 25791.87, filed on Nov. 12, 2001; and (2) U.S. utility patent application Ser. No. 10/495344, attorney docket number 25791.88.05, filed on May 12, 2004, which was filed as the National Stage application for PCT application serial number PCT/US2002/036267, attorney docket number 25791.88.02, filed on Nov. 12, 2002, which claimed the benefit of the filing date of U.S. provisional application Ser. No. 60/339013, attorney docket number 25791.88, filed on Nov. 12, 2001, the disclosures of which are incorporated herein by reference.

[0003] The present application is related to the following: (1) U.S. patent application Ser. No. 09/454,139, attorney docket no. 25791.03.02, filed on Dec. 3, 1999, (2) U.S. patent application Ser. No. 09/510,913, attorney docket no. 25791.7.02, filed on Feb. 23, 2000, (3) U.S. patent application Ser. No. 09/502,350, attorney docket no. 25791.8.02, filed on Feb. 10, 2000, (4) U.S. Pat. No. 6,328,113, (5) U.S. patent application Ser. No. 09/523,460, attorney docket no. 25791.11.02, filed on Mar. 10, 2000, (6) U.S. patent application Ser. No. 09/512,895, attorney docket no. 25791.12.02, filed on Feb. 24, 2000, (7) U.S. patent application Ser. No. 09/511,941, attorney docket no. 25791.16.02, filed on Feb. 24, 2000, (8) U.S. patent application Ser. No. 09/588,946, attorney docket no. 25791.17.02, filed on Jun. 7, 2000, (9) U.S. patent application Ser. No. 09/559,122, attorney docket no. 25791.23.02, filed on Apr. 26, 2000, (10) PCT patent application serial no.

PCT/US00/18635, attorney docket no. 25791.25.02, filed on Jul. 9, 2000, (11) U.S. provisional patent application Ser. No. 60/162,671, attorney docket no. 25791.27, filed on Nov. 1, 1999, (12) U.S. provisional patent application Ser. No. 60/154,047, attorney docket no. 25791.29, filed on Sep. 16, 1999, (13) U.S. provisional patent application serial no. **60/159,082**, attorney docket no. 25791.34, filed on Oct. 12, 1999, (14) U.S. provisional patent application Ser. No. 60/159,039, attorney docket no.25791.36, filed on Oct. 12, 1999, (15) U.S. provisional patent application Ser. No. 60/159,033, attorney docket no. 25791.37, filed on Oct. 12, 1999, (16) U.S. provisional patent application Ser. No. 60/212,359, attorney docket no. 25791.38, filed on Jun. 19, 2000, (17) U.S. provisional patent application Ser. No. 60/165,228, attorney docket no. 25791.39, filed on Nov. 12, 1999, (18) U.S. provisional patent application Ser. No. 60/221,443, attorney docket no. 25791.45, filed on Jul. 28, 2000, (19) U.S. provisional patent application Ser. No. 60/221,645, attorney docket no. 25791.46, filed on Jul. 28, 2000, (20) U.S. provisional patent application Ser. No. 60/233,638, attorney docket no. 25791.47, filed on Sep. 18, 2000, (21) U.S. provisional patent application Ser. No. 60/237,334, attorney docket no. 25791.48, filed on Oct. 2, 2000, (22) U.S. provisional patent application Ser. No. 60/270,007, attorney docket no. 25791.50, filed on Feb. 20, 2001, (23) U.S. provisional patent application Ser. No. 60/262,434, attorney docket no. 25791.51, filed on Jan. 17, 2001, (24) U.S. provisional patent application Ser. No. 60/259,486, attorney docket no. 25791.52, filed on Jan. 3, 2001, (25) U.S. provisional patent application Ser. No. 60/303,740, attorney docket no. 25791.61, filed on Jul. 6, 2001, (26) U.S. provisional patent application Ser. No. 60/313,453, attorney docket no. 25791.59, filed on Aug. 20, 2001, (27) U.S. provisional patent application Ser. No. 60/317,985, attorney docket no. 25791.67, filed on Sep. 6, 2001, (28) U.S. provisional patent application Ser. No. 60/3318,386, attorney docket no. 25791.67.02, filed on Sep. 10, 2001, (29) U.S. utility patent application Ser. No. 09/969,922, attorney docket no. 25791.69, filed on Oct. 3, 2001, (30) U.S. utility patent application Ser. No. 10/016,467, attorney docket no. 25791.70, filed on Dec. 10, 2001, (31) U.S. provisional patent application Ser. No. 60/343,674, attorney docket no. 25791.68, filed on Dec. 27, 2001, (32) U.S. provisional patent application Ser. No. 60/346,309, attorney docket no 25791.92, filed on Jan. 7, 2002, (33) U.S. provisional patent application Ser. No. 60/372,048, attorney docket no. 25791.93, filed on Apr. 12, 2002, (34) U.S. provisional patent application Ser. No. 60/380,147, attorney docket no. 25791.104, filed on May. 6, 2002, (35) U.S. provisional patent application Ser. No. 60/387,486, attorney docket no. 25791.107, filed on Jun. 10, 2002, (36) U.S. provisional patent application Ser. No. 60/387,961, attorney docket no. 25791.108, filed on Jun. 12, 2002, (37) U.S. provisional patent application Ser. No. 60/391,703, attorney docket no. 25791.90, filed on Jun. 26, 2002, (38) U.S. provisional patent application Ser. No. 60/397,284, attorney docket no. 25791.106, filed on Jul. 19, 2002, (39) U.S. provisional patent application Ser. No. 60/398,061, attorney docket no. 25791.110, filed on Jul. 24, 2002, (40) U.S. provisional patent application Ser. No. 60/405,610, attorney docket no. 25791.119, filed on Aug. 23, 2002, (41) U.S. provisional patent application Ser. No. 60/405,394, attorney docket no. 25791.120, filed on Aug. 23, 2002, (42) U.S. provisional patent application Ser. No. 60/412,177,

attorney docket no. 25791.117, filed on Sep. 20, 2002, (43) U.S. provisional patent application Ser. No. 60/412,653, attorney docket no. 25791.118, filed on Sep. 20, 2002, (44) U.S. provisional patent application Ser. No. 60/412,544, attorney docket no. 25791.121, filed on Sep. 20, 2002, (45) U.S. provisional patent application Ser. No. 60/412,187, attorney docket no. 25791.128, filed on Sep. 20, 2002, (46) U.S. provisional patent application Ser. No. 60/412,187, attorney docket no. 25791.127, filed on Sep. 20, 2002, (47) U.S. provisional patent application Ser. No. 60/412,487, attorney docket no. 25791.112, filed on Sep. 20, 2002, and (48) U.S. provisional patent application Ser. No. 60/412,488, attorney docket no. 25791.114, filed on Sep. 20, 2002, the disclosures of which are incorporated herein by reference.

#### BACKGROUND OF THE INVENTION

[0004] This invention relates generally to oil and gas exploration, and in particular to forming and repairing wellbore casings to facilitate oil and gas exploration.

[0005] Conventionally, when a wellbore is created, a number of casings are installed in the borehole to prevent collapse of the borehole wall and to prevent undesired outflow of drilling fluid into the formation or inflow of fluid from the formation into the borehole. The borehole is drilled in intervals whereby a casing which is to be installed in a lower borehole interval is lowered through a previously installed casing of an upper borehole interval. As a consequence of this procedure the casing of the lower interval is of smaller diameter than the casing of the upper interval. Thus, the casings are in a nested arrangement with casing diameters decreasing in downward direction. Cement annuli are provided between the outer surfaces of the casings and the borehole wall to seal the casings from the borehole wall. As a consequence of this nested arrangement a relatively large borehole diameter is required at the upper part of the wellbore. Such a large borehole diameter involves increased costs due to heavy casing handling equipment, large drill bits and increased volumes of drilling fluid and drill cuttings. Moreover, increased drilling rig time is involved due to required cement pumping, cement hardening, required equipment changes due to large variations in hole diameters drilled in the course of the well, and the large volume of cuttings drilled and removed.

[0006] The present invention is directed to overcoming one or more of the limitations of the existing procedures for forming and/or repairing wellbore casings.

#### SUMMARY OF THE INVENTION

[0007] According to one aspect of the present invention, an expansion cone assembly having two diameters for forming a skirt or bell section at which nested expandable tubular members overlap and for forming a mono diameter section of an expandable wellbore casing is provided.

#### BRIEF DESCRIPTION OF THE DRAWINGS

[0008] FIG. 1 is a schematic fragmentary cross-sectional illustration of an expandable tubular member and expansion cone assembly running through a mono diameter well bore casing formed according to one aspect to the invention.

[0009] FIG. 2 is a schematic fragmentary cross-sectional illustration of an expandable tubular member and expansion

cone assembly forming a bell portion of the mono diameter well bore casing of FIG. 1 according to one aspect to the invention.

[0010] FIG. 3 is a schematic fragmentary cross-sectional illustration of an expandable tubular member and expansion cone assembly forming a mono diameter portion of the mono diameter wellbore casing of FIGS. 1 and 2 according to another aspect to the invention.

[0011] FIG. 4 is a schematic fragmentary cross-sectional illustration of an expandable tubular member, a gripping mechanism within the tubular member, an actuator, an expansion cone assembly for forming a mono diameter casing and a float shoe supporting the tubular member for running into a wellbore.

[0012] FIG. 5 is a schematic fragmentary cross-sectional illustration of an expandable tubular member, a gripping mechanism engaging the tubular member, an actuator and expansion cone assembly for forming a mono diameter casing, with the tubular member lifted off the bottom of the wellbore and with the expansion cone assembly pushed by the actuator into an open wellbore.

[0013] FIG. 6 is a schematic fragmentary cross-sectional illustration of the expansion cone assembly expanded for radially expanding and plastically deforming the expandable tubular member.

[0014] FIGS. 7a-7e are fragmentary cross-sectional illustrations of the placement of an exemplary embodiment of an apparatus for forming a mono diameter wellbore casing within a wellbore that traverses a subterranean formation.

[0015] FIGS. 8a-8e are fragmentary cross-sectional illustrations of the apparatus of FIGS. 7a-7e after placement on the bottom of the wellbore.

[0016] FIGS. 9a-9e are fragmentary cross-sectional illustrations of the apparatus of FIGS. 8a-8e after placing a ball or dart within the ball or dart seat to initiate the radial expansion and plastic deformation of the expandable tubular member.

[0017] FIGS. 10a-10e are fragmentary cross-sectional illustrations of the apparatus of FIGS. 9a-9e after the initiation of the radial expansion and plastic deformation of the aluminum sleeve within the shoe.

[0018] FIG. 11a-11b is a fragmentary cross-sectional illustration of an exemplary embodiment of an apparatus for radially expanding and plastically deforming a tubular member that includes an adjustably expandable expansion cone assembly.

[0019] FIG. 12 is a fragmentary cross-sectional illustration of an upper cone portion of the apparatus for radially expanding and plastically deforming a tubular member of FIGS. 11a-11b.

[0020] FIG. 13 is a fragmentary cross-sectional illustration of a lower cone portion of the apparatus for radially expanding and plastically deforming a tubular member of FIGS. 11a-11b.

[0021] FIG. 14 is a fragmentary cross-sectional illustration of an overlapping portion of the apparatus for radially expanding and plastically deforming a tubular member of FIGS. 11a-11b, 12 and 13.

[0022] FIG. 15 is a fragmentary cross-sectional and perspective illustrations of the upper cam assembly of the apparatus for radially expanding and plastically deforming a tubular member of FIGS. 11a-11b.

[0023] FIG. 16 is a fragmentary cross-sectional and perspective illustrations of the lower cam assembly of the apparatus for radially expanding and plastically deforming a tubular member of FIGS. 11a-11b.

[0024] FIG. 17a-17b is a fragmentary cross-sectional illustration of an exemplary embodiment of an apparatus for radially expanding and plastically deforming a tubular member that includes an adjustably expandable expansion cone assembly of FIGS. 11a-11b activated for cementing.

[0025] FIG. 18a-18b is a fragmentary cross-sectional illustration of an exemplary embodiment of an apparatus for radially expanding and plastically deforming a tubular member that includes an adjustably expandable expansion cone assembly of FIGS. 11a-11b activated for adjusting the expansion diameter.

[0026] FIG. 19 is a fragmentary cross-sectional illustration of an overlapping portion of the apparatus for radially expanding and plastically deforming a tubular member adjusted to an intermediate expansion diameter.

[0027] FIG. 20a-20b are fragmentary cross sectional illustrations of the apparatus of FIGS. 10d-10e after the completion of the radial expansion and plastic deformation of the aluminum sleeve within the shoe.

[0028] FIGS. 21a-21b are fragmentary cross-sectional illustrations of the apparatus of FIGS. 20a-20b after displacing the sliding sleeve valve within the shoe to permit circulation around the ball or dart.

[0029] FIGS. 22a-22b are fragmentary cross sectional illustrations of the apparatus of FIGS. 21a-21b during the injection of cement into the annulus between the radially expanding tubular member and the wellbore using the bypass circulation provided by the displaced sliding sleeve valve within the shoe.

#### DETAILED DESCRIPTION OF THE ILLUSTRATIVE EMBODIMENTS

[0030] FIGS. 1-6 illustrate several illustrative embodiments of a device and method for forming a mono diameter well bore casing using an expansion assembly including two cone diameters, one of which is larger than the other for forming a bell (sometimes called a skirt) section for overlapping expandable tubular members so that the effort required for the expansion assembly to expanded two overlapping tubular members is reduced. The other cone diameter is sized for expanding the tubular members to the desired diameter along the length of the tubular member thereby resulting in a mono-diameter well bore casing. The two diameters may be provided with a conventional adjustable size expansion cone having two expansion diameters, one larger than the other. The larger diameter is adjusted to a smaller diameter after a bell section of an expandable tubular member is formed and then the remainder of the expandable tubular member is expanded to a the desired internal diameter for the mono diameter wellbore casing. Conventional adjustably expandable cones can be used according to the invention. In several alternative embodi-

ments, the invention is implemented as described in FIGS. 7a-7e, 8a-8e, 9a-9e, 10a-10e, 11a-11b and 17a-17b, 18a-18b and 19a-19b with an exemplary adjustably expandable cone assembly as described in greater detail herein with reference to FIGS. 11a-11b, 12, 13, 14, 15 and 16. In other alternative embodiments the adjustably expandable cones of the invention may be implemented or using the methods and/or apparatus disclosed one or more of the following: (1) U.S. patent application Ser. No. 09/454,139, attorney docket no. 25791.03.02, filed on Dec. 3, 1999, (2) U.S. patent application Ser. No. 09/510,913, attorney docket no. 25791.7.02, filed on Feb. 23, 2000, (3) U.S. patent application Ser. No. 09/502,350, attorney docket no. 25791.8.02, filed on Feb. 10, 2000, (4) U.S. Pat. No. 6,328,113, (5) U.S. patent application Ser. No. 09/523,460, attorney docket no. 25791.11.02, filed on Mar. 10, 2000, (6) U.S. patent application Ser. No. 09/512,895, attorney docket no. 25791.12.02, filed on Feb. 24, 2000, (7) U.S. patent application Ser. No. 09/511,941, attorney docket no. 25791.16.02, filed on Feb. 24, 2000, (8) U.S. patent application Ser. No. 09/588,946, attorney docket no. 25791.17.02, filed on Jun. 7, 2000, (9) U.S. patent application Ser. No. 09/559,122, attorney docket no. 25791.23.02, filed on Apr. 26, 2000, (10) PCT patent application serial no. PCT/US00/18635, attorney docket no. 25791.25.02, filed on Jul. 9, 2000, (11) U.S. provisional patent application Ser. No. 60/162,671, attorney docket no. 25791.27, filed on Nov. 1, 1999, (12) U.S. provisional patent application Ser. No. 60/154,047, attorney docket no. 25791.29, filed on Sep. 16, 1999, (13) U.S. provisional patent application Ser. No. 60/159,082, attorney docket no. 25791.34, filed on Oct. 12, 1999, (14) U.S. provisional patent application Ser. No. 60/159,039, attorney docket no. 25791.36, filed on Oct. 12, 1999, (15) U.S. provisional patent application Ser. No. 60/159,033, attorney docket no. 25791.37, filed on Oct. 12, 1999, (16) U.S. provisional patent application Ser. No. 60/212,359, attorney docket no. filed on Jun. 19, 2000, (17) U.S. provisional patent application Ser. No. 60/165,228, attorney docket no. 25791.39, filed on Nov. 12, 1999, (18) U.S. provisional patent application Ser. No. 60/221,443, attorney docket no. 25791.45, filed on Jul. 28, 2000, (19) U.S. provisional patent application Ser. No. 60/221,645, attorney docket no. 25791.46, filed on Jul. 28, 2000, (20) U.S. provisional patent application Ser. No. 60/233,638, attorney docket no. 25791.47, filed on Sep. 18, 2000, (21) U.S. provisional patent application Ser. No. 60/237,334, attorney docket no. 25791.48, filed on Oct. 2, 2000, (22) U.S. provisional patent application Ser. No. 60/270,007, attorney docket no. 25791.50, filed on Feb. 20, 2001, (23) U.S. provisional patent application Ser. No. 60/262,434, attorney docket no. 25791.51, filed on Jan. 17, 2001, (24) U.S. provisional patent application Ser. No. 60/259,486, attorney docket no. 25791.52, filed on Jan. 3, 2001, (25) U.S. provisional patent application Ser. No. 60/303,740, attorney docket no. 25791.61, filed on Jul. 6, 2001, (26) U.S. provisional patent application Ser. No. 60/313,453, attorney docket no. 25791.59, filed on Aug. 20, 2001, (27) U.S. provisional patent application Ser. No. 60/317,985, attorney docket no. 25791.67, filed on Sep. 6, 2001, (28) U.S. provisional patent application Ser. No. 60/3318,386, attorney docket no. 25791.67.02, filed on Sep. 10, 2001, (29) U.S. utility patent application Ser. No. 09/969,922, attorney docket no. 25791.69, filed on Oct. 3, 2001, (30) U.S. utility patent application Ser. No. 10/016,467, attorney docket no.

25791.70, filed on Dec. 10, 2001, (31) U.S. provisional patent application Ser. No. 60/343,674, attorney docket no. 25791.68, filed on Dec. 27, 2001, (32) U.S. provisional patent application Ser. No. 60/346,309, attorney docket no. 25791.92, filed on Jan. 7, 2002, (33) U.S. provisional patent application Ser. No. 60/372,048, attorney docket no. 25791.93, filed on Apr. 12, 2002, (34) U.S. provisional patent application Ser. No. 60/380,147, attorney docket no. 25791.104, filed on May 6, 2002, (35) U.S. provisional patent application Ser. No. 60/387,486, attorney docket no. 25791.107, filed on Jun. 10, 2002, (36) U.S. provisional patent application Ser. No. 60/387,961, attorney docket no. 25791.108, filed on Jun. 12, 2002, (37) U.S. provisional patent application Ser. No. 60/391,703, attorney docket no. 25791.90, filed on Jun. 26, 2002, (38) U.S. provisional patent application Ser. No. 60/397,284, attorney docket no. 25791.106, filed on Jul. 19, 2002, (39) U.S. provisional patent application Ser. No. 60/398,061, attorney docket no. 25791.110, filed on Jul. 24, 2002, (40) U.S. provisional patent application Ser. No. 60/405,610, attorney docket no. 25791.119, filed on Aug. 23, 2002, (41) U.S. provisional patent application Ser. No. 60/405,394, attorney docket no. 25791.120, filed on Aug. 23, 2002, (42) U.S. provisional patent application Ser. No. 60/412,177, attorney docket no. 25791.117, filed on Sep. 20, 2002, (43) U.S. provisional patent application Ser. No. 60/412,653, No. 60/412,544, attorney docket no. 25791.121, filed on Sep. 20, 2002, (45) U.S. provisional patent application Ser. No. 60/412,187, attorney docket no. 25791.128, filed on Sep. 20, 2002, (46) U.S. provisional patent application Ser. No. 60/412,187, attorney docket no. 25791.127, filed on Sep. 20, 2002, (47) U.S. provisional patent application Ser. No. 60/412,487, attorney docket no. 25791.112, filed on Sep. 20, 2002, and (48) U.S. provisional patent application Ser. No. 60/412,488, attorney docket no. 25791.114, filed on Sep. 20, 2002, the disclosures of which are incorporated herein by reference.

[0031] FIG. 1 shows a schematic illustration of an apparatus 10 in a wellbore 12 with an expandable tubular member 14 and an expansion cone assembly 16 supported by a tubular support 30 (such as a drill pipe 30), all supported by a float shoe 32 for running into a wellbore 12 through a plurality of casing sections 18a and 18b of a mono diameter wellbore casing 18 in the process of being formed, according to one aspect to the invention. The existing casing 18 sections 18a and 18b have been formed from expandable tubular members 14 and according to the teachings of the present invention include mono diameter portions 28a and 28b with a first inside diameter ID1 and bell portions 22a and 22b having a second inside diameter inside diameter ID2 and a length L. There is an overlapping portion 26 where the bell portions 22a overlap of the casing section 18b.

[0032] FIG. 2 shows a schematic illustration of the expandable tubular member 14, acted upon by a large cone 20 of the expansion cone assembly 16 to expand the diameter of the lower end of the expandable tubular member 14 to form a bell portion 22. The bell portion 22 is formed by the large cone 20 of the expansion cone assembly 16 that has an adjustable cone diameter sufficiently large so that the resulting expanded inside diameter of the bell portion 20 is at least slightly larger than a desired inside diameter of the mono diameter wellbore casing 18. The length of the bell portion 20 depends upon the desired length of overlapping

lengths 26 between nested casing sections 18a, 18b, and 18c. For example, it is contemplated applicants that the overlap length 26 and therefore the bell portion 22 may have a length up to about 100 feet or up to about 150 feet.

[0033] FIG. 3 shows a schematic illustration of the expandable tubular member 14 of FIG. 2, with the expansion cone assembly 16 positioned for expanding the expandable tubular member 14 to the desired mono diameter at the portion 28 above the bell portion 22. In this configuration the diameter of the large adjustable cone 20 is collapsed, or is otherwise adjusted, to a smaller diameter. Another cone 24, having a diameter smaller than the large diameter of cone 20, is provided for radially expanding the tubular member 14 to the desired inside diameter of the mono diameter wellbore casing. The wellbore casing section 18c of the mono diameter well bore casing 18 of FIGS. 1 and 2, overlaps with the wellbore casing section 18b along the overlapping length 26 and at the bell portion 22b. The inside diameter of the bell portion 22 and the outside diameter of the mono diameter portion 28 are the same to provide a tight fitting junction between the nested sections 18a, b, c and etc. For example, where the expandable tubular member 14 has a wall thickness of about 0.35 inches and for the desired inside diameter of the mono diameter wellbore casing is about 10.3 inches, after expansion, the inside diameter of the bell portion might be about 11.0 inches, or slightly less to provide a tight fit between the overlapping portions of the casing sections 18a, b, c and etc.

[0034] The large diameter cone 20 can be positioned above, below or effectively at the same position as the small diameter cone 24, without departing from certain aspects of the invention. Also, it will be understood by those of ordinary skill in the art, and based upon this disclosure, that the large diameter corresponding to the inside diameter of the bell portion can be provided by a first collapsible or adjustable cone 22, that provides the desired bell portion diameter and that can be collapsed to a smaller diameter, together with a second cone 24 that provides the diameter for forming the mono diameter well bore casing. It will also be understood that in an alternative embodiment the expansion to the mono diameter can be provided by adjusting the diameter of cone 22 to effectively become the smaller diameter cone 24 having a diameter corresponding to the desired mono diameter. It will further be understood that in another alternative embodiment the cone 24 is a distinct cone 24 either fixed at the desired mono diameter size or expandable to the desired mono diameter size.

[0035] FIG. 4 shows a schematic mono diameter casing forming apparatus 10, further depicting one arrangement of a mechanism for activating the expansion cone assembly 16 to expand the tubular member 14. The apparatus 10 is shown in a configuration for running into a wellbore 12. A drill pipe 30 supports the apparatus 10, as it is running down into the wellbore 12, with a connected float shoe 32. The drill pipe 30 may be a conventional drill pipe or other conventional down hole tubular support member. The float shoe may be a conventional float shoe or other tool guiding structure that serves the describe purpose attached to the drill pipe or other tubular support member. The float shoe 32 thus supports the new expandable tubular member 14 that is to be added to and expanded for engagement with the lower end of the mono diameter wellbore casing 18 that has been previously formed. An gripping tool 34, sometimes called an anchor



that may be a device as shown or a conventional gripping tool or anchor, is provided to hold the expandable tubular member 14 fixed relative to one end of a hydraulic actuator 36, sometimes called a force multiplier mechanism that may be a device as shown or a conventional actuator or force multiplier. The hydraulic actuator 36 is configured and actuatable for moving the expansion cone assembly 16 relative to the expandable member 14, either in tension using sub 36a or in compression using sub 36b.

[0036] FIG. 5 schematically shows an embodiment of the mono diameter casing forming apparatus 10, with the gripping mechanism 34 engaging the tubular member 14, with the tubular member 14 lifted off the bottom of the well bore 12 and with the expansion cone 16 pushed by actuator 36 into the open wellbore 12. A conventional dart 53 or ball is dropped to seal the float shoe 32, or another conventional shut-off device such as a mechanical valve or a velocity valve is used and activated, so that fluid 38 forced through the drill pipe 22 increases pressure to activate the gripping tool 26. When the drill pipe 22 is set down at the bottom of the hole, the tension sub 36a of the actuator mechanism 36 is actuated. Pressure is increased in the drill pipe 30 and the gripping mechanism 34 is engaged to anchor the tubular member 14. Compression sub 36b is activated to lift the tubular liner 14 off the bottom of the wellbore and to push the cone assembly 16 into the open hole of wellbore 12.

[0037] FIG. 6 shows the expansion cone assembly 16 expanded for radially expanding and plastically deforming the expandable tubular member 14. The expansion of the expansion cone assembly is activated in a conventional manner, as with a dart 42 that is passed with the fluid 38 down through the drill pipe 30 to thereby cause appropriate port alignment and/or appropriate valve activation for the expansion cone assembly 16. An optional sacrificial protective sleeve 40 that protects the expansion cone assembly 16 while it is running into the wellbore breaks off when the expansion cone assembly is expanded. The protective sleeve 40 may be formed of a plastic or composite material so that the sacrificial protective sleeve easily breaks off and does not interfere with the expansion of the tubular member 14.

[0038] In an exemplary embodiment, as illustrated in FIGS. 7a-7e, an apparatus 10 for forming a mono diameter wellbore casing 18 is positioned within a wellbore 12. The apparatus 10 includes, among other things, an expandable tubular member 14 and an adjustable expansion cone assembly 16. During placement of the apparatus 10 within the wellbore 12, the expandable tubular member 14 may be supported by the grip tool 34 and/or the expansion cone assembly 16 and/or the float shoe 32.

[0039] In an exemplary embodiment, as illustrated in FIGS. 8a-8e, the apparatus 10 is then positioned into contact with the bottom 44 of the wellbore 12. As a result, a shear pin 46 is sheared and a dog locking sleeve 48 is driven upwardly thereby displacing a plurality of dogs 50 outwardly in the radial direction in a conventional manner.

[0040] In an exemplary embodiment, as illustrated in FIGS. 9a- 9e, a ball 52 or conventional dart may then be placed within the ball or dart seat 54 of the apparatus by injecting fluidic material 38 into the apparatus 10. As a result, the flow of fluidic material 38 through the float shoe 32 is blocked. The expansion cone assembly is also actuated in a conventional manner, for example with the pressure

caused by the ball 52 or a dart 42 (as shown in FIG. 6 above), to expand to the large diameter for expanding the bell. Pressure builds and the actuator 36 is activated in tension to draw the large cone 20 upward partially through the expandable tubular member 14. Pressure can be released and reactivated in the actuator 36 and gripping tool 34 to repeatedly stroke the large cone 20 of the expansion cone assembly 16 along the desired overlapping length L of the casing to thereby form the bell portion 22 of the casing.

[0041] In an exemplary embodiment, as illustrated in FIGS. 10a-10e, the large diameter cone 20 is actuated to collapse or adjust to a smaller diameter cone 24 corresponding to the desired diameter of the mono diameter casing 18, using conventional actuation, for example, increased fluidic pressure and a rupture disc in an appropriate port (not shown) or an additional dart 56 injected with the fluidic material 38 into the apparatus 10 to a conventional dart seat 58. The gripping tool 34 is activated to lock the top end of the hydraulic actuator 36 to the expandable tubular member 14. The injected fluidic material 38 also causes the adjustable cone 24 to reach the desired diametrical size for forming the mono diameter casing 18. The continued injection of the fluidic material 38 furthermore increases the operating pressure within the apparatus thereby causing the hydraulic actuator 36 to pull the expansion cone 24 into the expandable tubular member 14. As a result, the expandable tubular member 14 is radially expanded.

[0042] The continued upward movement of the expansion cone pulls the float shoe 32 to the bottom end of the radially expanded tubular member 14. As a result, the end of the radially expanded tubular member 14 will impact the dogs 50 thereby preventing the float shoe 32 from moving further in the upward direction. The continued upward movement of the expansion cone then will pull a sleeve expander cone 60 for the sleeve 62 upwardly thereby radially expanding a sleeve of the float shoe within the float shoe.

[0043] In one exemplary embodiment, as illustrated in FIGS. 11a-11b, 12, 13, 14, 15 and 16, the expansion cone assembly 16 is adjustable for providing two outside diameters, one outside diameter larger than the other outside diameter. The construction of the expandable cone assembly may also be constructed in accordance with the principles and design disclosed in U.S. provisional patent application Ser. No. 60/387,961, attorney docket no. 25791.108, filed on Jun. 12, 2002, the disclosure of which is incorporated herein by reference. An exemplary embodiment includes a tubular support member 64 coupled to an end of a safety collar 66 that defines a passage 66a and a recess 66b, at one end for receiving the end of the tubular support member 14, and recesses 66c and 66d at another end.

[0044] A torque plate 68 is received within and is coupled to the recess 66c of the safety collar 66 that defines a passage 68a and a plurality of meshing teeth 68b at one end. An end of an upper mandrel collar 70 is received with and is coupled to the recess 66d of the safety collar 66 proximate an end of the torque plate 68 that defines a passage 68a. Torque pins 72a and 72b further couple the end of the upper mandrel collar 70 to the end of the safety collar 66.

[0045] An end of an upper mandrel 74 is received within and is coupled to the upper mandrel collar 70 that defines a passage 74a, a plurality of meshing teeth 74b that mate with and transmit torque to and from the meshing teeth 68b of the torque plate 68, and an external flange 74c at another end.

[0046] An upper packer cup 76 mates with, receives and is coupled to the upper mandrel 74 proximate the end of the upper mandrel collar 70. In an exemplary embodiment, the upper packer cup 76 is a conventional Guiberson™ packer cup. An upper spacer sleeve 78 mates with, receives, and is coupled to the upper mandrel 74 proximate an end of the upper packer cup 76. A lower packer cup 80 mates with, receives and is coupled to the upper mandrel 74 proximate an end of the upper spacer sleeve 78. In an exemplary embodiment, the lower packer cup 80 is a conventional Guiberson™ packer cup. A lower spacer sleeve 82 mates with, receives, and is coupled to the upper mandrel 74 proximate an end of the lower packer cup 80 and the external flange 74c of the upper mandrel. A retaining sleeve 84 mates with, receives, and is coupled to an end of the lower spacer sleeve proximate the external flange 74c of the upper mandrel 74.

[0047] An end of a lower mandrel 86 defines a recess 86a that mates with, receives, and is coupled to the external flange 74c of the upper mandrel 74, a recess 86b that mates with, receives, and is coupled to the end of the upper mandrel, a passage 86c, and an external flange 86d including circumferentially spaced apart meshing teeth 86da on an end face of the external flange. Torque pins 88a and 88b further couple the recess 86a of the end of the lower mandrel 86 to the external flange 74c of the upper mandrel 74. During operation, the torque pins 88a and 88b transmit torque loads between the recess 86a of the end of the lower mandrel 86 and the external flange 74c of the upper mandrel 74.

[0048] An upper cam assembly 90 includes a tubular base 90a for receiving and mating with the lower mandrel 86 that includes an external flange 90aa, a plurality of circumferentially spaced apart meshing teeth 90b that extend from one end of the tubular base in the longitudinal and radial directions for engaging the meshing teeth 86da of the end face of the external flange 86d of the lower mandrel 86, and a plurality of circumferentially spaced apart cam arms 90c that extend from the other end of the tubular base in the opposite longitudinal direction and mate with and receive the lower mandrel 86. During operation, the meshing teeth 86da of the end face of the external flange 86d of the lower mandrel 86 transmit torque loads to the meshing teeth 90b of the upper cam assembly 90. Each of the cam arms 90c include an inner portion 90ca extending from the tubular base 90a that has arcuate cylindrical inner 90caa and outer 90cab surfaces, a tapered intermediate portion extending from the inner portion 90cb that has an arcuate cylindrical inner surface 90cba and an arcuate conical outer surface 90bbb, and an outer portion 90cc extending from the intermediate portion 90cc that has arcuate cylindrical inner 90cca and outer surfaces 90ccb.

[0049] A lower cam assembly 92 includes a tubular base 92a for receiving and mating with the lower mandrel 86 that includes an external flange 92aa, a plurality of circumferentially spaced apart meshing teeth 92b that extend from one end of the tubular base in the longitudinal and radial directions, and a plurality of circumferentially spaced apart cam arms 92c that extend from the other end of the tubular base in the opposite longitudinal direction and mate with and receive the lower mandrel 86. Each of the cam arms 92c include an inner portion 92ca extending from the tubular base 92a that has arcuate cylindrical inner 92caa and outer 92cab surfaces, a tapered intermediate portion 92cb extend-

ing from the inner portion 92ca that has an arcuate cylindrical inner surface 92cba and an arcuate conical outer surface 92cbb, and an outer portion 92cc extending from the intermediate portion 92cb that has arcuate cylindrical inner 92cca and outer 92ccb surfaces.

[0050] In an exemplary embodiment, the upper and lower cam assemblies, 90 and 92, are substantially identical. In an exemplary embodiment, the cam arms 90c of the upper cam assembly 90 interleave the cam arms 92c of the lower cam assembly 92. Furthermore, in an exemplary embodiment, the cam arms 90c of the upper cam assembly also overlap with the cam arms 92c of the lower cam assembly 92 in the longitudinal direction thereby permitting torque loads to be transmitted between the upper and lower cam assemblies.

[0051] A plurality of upper expansion cone segments 96 are interleaved among the cam arms 90c of the upper cam assembly 90. Each of the upper expansion cone segments 96 include inner portions 96a having arcuate cylindrical inner surfaces 96aa, and an arcuate cylindrical outer surface 96ab, intermediate portions 96b extending from the interior portions that have an arcuate conical inner surface 96ba and arcuate cylindrical and spherical outer surfaces, 96bb, and outer portions 96c having arcuate cylindrical inner and outer surfaces, 96ca and 96cb. In an exemplary embodiment, the outer surfaces 96ab of the inner portions 96a of the upper expansion cone segments 96 define hinge grooves 96d that receive and are pivotally mounted upon the internal flange 94d of the upper retaining sleeve 94.

[0052] The arcuate inner cylindrical surfaces of the inner portion 96a mate with and receive the lower mandrel 86, the arcuate inner cylindrical surfaces of the inner portion 96a also mate with and receive the arcuate cylindrical outer surfaces of the outer portions 92cc of the corresponding cam arms 92c of the lower cam assembly 92, and the arcuate inner conical surfaces 96ba of the inner portion 96a mate with and receive the arcuate conical outer surfaces of the intermediate portions 92cb of the corresponding cam arms 92c of the lower cam assembly 92.

[0053] A plurality of lower expansion cone segments 98 are interleaved among, and overlap, the upper expansion cone segments 96 and the cam arms 90c of the lower cam assembly 90. In this manner, torque loads may be transmitted between the upper and lower expansion cone segments, 96 and 98. Each of the lower expansion cone segments 98 include inner portions 98a having arcuate cylindrical inner surfaces, 98aa, and an arcuate cylindrical outer surface 98ab, intermediate portions 98b extending from the interior portions that have an arcuate conical inner surface 98ba and arcuate cylindrical and spherical outer surfaces, 98bb, and outer portions 98c having arcuate cylindrical inner and outer surfaces, 98ca and 98cb. In an exemplary embodiment, the outer surfaces 98ab of the inner portions 98a of the upper expansion cone segments 98 define hinge grooves 98aba that receive and are pivotally mounted upon the internal flange 100d of a lower retaining sleeve 100.

[0054] The arcuate inner cylindrical surfaces 98aa mate with and receive the lower mandrel 86, the arcuate inner cylindrical surfaces 98aa also mate with and receive the arcuate cylindrical outer surfaces of the outer portions 90cc of the corresponding cam arms 90c of the upper cam assembly 90, and the arcuate inner conical surfaces 98ba mate with and receive the arcuate conical outer surfaces of

the intermediate portions **90cb** of the corresponding cam arms **90c** of the lower cam assembly **90**.

[0055] In an exemplary embodiment, the geometries of the upper and lower expansion cone segments **96** and **98** are substantially identical. In an exemplary embodiment, the upper expansion cone segments **96** are tapered in the longitudinal direction from the ends of the intermediate portions **96b** to the ends of the outer portions **96c**, and the lower expansion cone segments **98** are tapered in the longitudinal direction from the ends of the intermediate portions **98b** to the ends of the outer portions **98c**. In an exemplary embodiment, when the upper and lower expansion segments, **96** and **98**, are positioned in a fully expanded position, the arcuate cylindrical outer surfaces **96ab** of the upper and lower expansion cone segments **96** define a contiguous cylindrical surface, the arcuate spherical outer surfaces of the upper and lower expansion cone segments, **96bb** and **98bb**, define a contiguous arcuate spherical surface, and the arcuate cylindrical outer surfaces of the upper and lower expansion cone segments define a contiguous cylindrical surface.

[0056] An end of a lower retaining sleeve **100** defines a passage **100a** for receiving and mating with the outer circumferential surfaces of the external flange **92aa** and the meshing teeth **92b** of the lower cam assembly **92**, and an inner annular recess **100b**, and includes an internal flange **100c** for retaining the external flange of the lower cam assembly, and an internal flange **100d** at one end of the lower retaining sleeve that includes a rounded interior end face for mating with corresponding hinge grooves of the lower expansion cone segments **98** thereby pivotally coupling the lower expansion cone segments to the lower retaining sleeve.

[0057] In an exemplary embodiment, the arcuate cylindrical outer surfaces of the upper expansion cone segments **96** and the arcuate cylindrical outer surfaces of the lower expansion cone segments **98** are aligned with the outer surface of the upper retaining sleeve **94**. In an exemplary embodiment, the arcuate cylindrical outer surfaces of the upper expansion cone segments **96** and the arcuate cylindrical outer surfaces of the lower expansion cone segments are aligned with the outer surface of the lower retaining sleeve **100**.

[0058] An end of a float shoe adaptor **102** that includes a plurality of circumferentially spaced apart meshing teeth **102a** for engaging the meshing teeth **92b** of the lower cam assembly **92** is received within and threadably coupled to an end of the lower retaining sleeve **100** that defines a passage **102b** at one end for receiving an end of the lower mandrel **86**, a passage **102c** having a reduced inside diameter at another end, a plurality of radial passages **102d** at the other end, and includes an internal flange **102e**, and a torsional coupling **102f** at the other end that includes a plurality of torsional coupling members **102fa**. During operation, the meshing teeth **92b** of the lower cam assembly **92** transmit torque loads to and from the meshing teeth **102a** of the float shoe adaptor.

[0059] An end of a retaining sleeve **104** abuts the end face of the tubular base **92a** of the lower cam assembly **92** and is received within and mates with the passage **102b** of the float shoe adaptor **102** that defines a passage **104a** for receiving an end of the lower mandrel **86**, a throat passage **104b** including a ball valve seat **104c**, and includes a flange **104d**,

and another end of the retaining sleeve, having a reduced outside diameter, is received within and mates with the passage **102c** of the float shoe adaptor **102**.

[0060] A stop nut **106** receives and is threadably coupled to the end of the lower mandrel **86** within the passage **104a** of the retaining sleeve **104**, and shear pins **108** releasably couple the stop nut **106** to the retaining sleeve **104**. Locking dogs **110** are positioned within an end of the retaining sleeve **104** that receive and are releasably coupled to the lower mandrel **86**, and a disc shaped adjustment shim **112** receives the lower mandrel **86** and is positioned within an end of the retaining sleeve **104** between the opposing ends of the tubular base **92a** of the upper cam assembly **92** and the locking dogs **110**. Burst discs **114** are releasably coupled to and positioned within the radial passages **102d** of the float shoe adaptor **102**.

[0061] An end of a float shoe **116** mates with and is releasably coupled to the torsional coupling **102f** of the float shoe adaptor **102** that defines a passage **116a** and a valveable passage **116b**. In this manner torsional loads may be transmitted between the float shoe adaptor **102** and the float shoe **116**. An end of an expandable tubular member **14** that surrounds the tubular support member **64**, the safety collar **66**, the upper mandrel collar **70**, the upper packer cup **76**, the lower packer cup **80**, the lower mandrel **86**, the upper expansion cone segments **96**, the lower expansion cone segments **98**, and the float shoe adaptor **102**, is coupled to and receives an end of the float shoe **116** and is movably coupled to and supported by the arcuate spherical external surfaces, **96bb** and **98bb**, of the upper and lower expansion cone segments, **96** and **98**.

[0062] During operation, the apparatus **10** is at least partially positioned within a preexisting structure such as, for example, a borehole **12** that traverses a subterranean formation that may include a preexisting wellbore casing **18**. The borehole **12** may be oriented in any position, for example, from vertical to horizontal. A fluidic material **38** is then injected into the apparatus **10** through the passages **64a**, **66a**, **74a**, **86c**, **102c**, **116a**, and **116b** into the annulus between the expandable tubular member **14** and the borehole **12**. In an exemplary embodiment, the fluidic material **104** is a hardenable fluidic sealing material. In this manner, an annular sealing layer may be formed within the annulus between the expandable tubular member **14** and the borehole **12**.

[0063] As illustrated in FIGS. **17a** and **17b**, a ball **55** is then be positioned within and blocking the valveable passage **116b** of the float shoe **116** by injecting a fluidic material **38** into the apparatus **10** through the passages **64a**, **66a**, **74a**, **86c**, and **102c**. As a result, the increased operating pressure within the passage **102c** bursts open the burst discs **114** positioned within the radial passages **102d** of the float shoe adaptor **102**. The continued injection of the fluidic material **38** thereby pressurizes the interior of the expandable tubular member **14** below the lower packer cup **80** thereby displacing the upper and lower expansion cone segments, **96** and **98**, upwardly relative to the float shoe **116** and the expandable tubular member **14**. As a result, the expandable tubular member **14** is plastically deformed and radially expanded. Thus, the burst discs **114** sense the operating pressure of the injected fluidic material **38** within the passage **102c** and thereby control the initiation of the radial expansion and plastic deformation of the expandable tubular member **14**.

[0064] In an exemplary embodiment, any leakage of the pressurized fluidic material **38** past the lower packer cup **80** is captured and sealed against further leakage by the upper packer cup **76**. In this manner, the lower packer cup **80** provides the primary fluidic seal against the interior surface of the expandable tubular member **14**, and the upper packer cup **76** provides a secondary, back-up, fluidic seal against the interior surface of the expandable tubular member. Furthermore, because the lower packer cup **80** and/or the upper packer cup **76** provide a fluid tight seal against the interior surface of the expandable tubular member **14**, the upper and lower expansion cone segments, **96** and **98**, are pulled upwardly through the expandable tubular member by the axial forces created by the packer cups.

[0065] In an exemplary embodiment, during the radial expansion process, the interface between the arcuate spherical external surfaces, **96bb** and **98bb**, of the upper and lower expansion cone segments, **96** and **98**, and the interior surface of the expandable tubular member **14** is not fluid tight. As a result, the fluidic material **38** may provide lubrication to the entire extent of the interface between the cylindrical external surfaces, **96bba** and **98cb**, and the arcuate spherical external surfaces, **96bb** and **98bb**, of the upper and lower expansion cone segments, **96** and **98**, and the interior surface of the expandable tubular member **14**. Moreover, experimental test results have indicated the unexpected result that the required operating pressure of the fluidic material **38** for radial expansion of the expandable tubular member **14** is less when the interface between the cylindrical external surfaces, **96bba** and **98cb**, and the arcuate spherical external surfaces, **96bb** and **98bb**, of the upper and lower expansion cone segments, **96** and **98**, and the interior surface of the expandable tubular member **14** is not fluid tight. Furthermore, experimental test results have also demonstrated that the arcuate spherical external surface provided by the arcuate spherical external surfaces, **96bb** and **98bb**, of the upper and lower expansion cone segments, **96** and **98**, provides radial expansion and plastic deformation of the expandable tubular member **14** using lower operating pressures versus an expansion cone having a conical outer surface.

[0066] In an exemplary embodiment, as illustrated in FIGS. **18a**, **18b** and **19**, the upper and lower expansion cone segments, **96** and **98**, may then be adjusted to a desired expansion diameter by placing a ball **57** within the ball valve seat **104c** of the throat passage **104b** of the retaining sleeve **104**. The continued injection of the fluidic material **38**, after the placement of the ball **57** within the ball valve seat **104c**, creates a differential pressure across the ball **57** thereby applying a downward longitudinal force onto the retaining sleeve **104** thereby shearing the shear pins **108**. As a result, the retaining sleeve **104** is displaced in the downward longitudinal direction relative to the float shoe adaptor **102** thereby permitting the locking dogs **110** to be displaced outwardly in the radial direction. The outward radial displacement of the locking dogs **110** disengages the locking dogs from engagement with the lower mandrel **86**. Thus, the shear pins **108** sense the operating pressure of the injected fluidic material **38** within the throat passage **104b** and thereby controlling the initiation of the collapsing of the upper and lower expansion cone segments, **96** and **98** to a smaller diameter.

[0067] The continued injection of the fluidic material **38** continues to displace the retaining sleeve **104** in the down-

ward longitudinal direction relative to the float shoe adaptor **102** until the external flange **104d** of the retaining sleeve **104** impacts, and applies a downward longitudinal force to, the internal flange **102e** of the float shoe adaptor. As a result, the float shoe adaptor **102** is then also displaced in the downward longitudinal direction relative to the lower mandrel **86**. The downward longitudinal displacement of the float shoe adaptor **102** relative to the lower mandrel **86** causes the lower cam assembly **92**, the lower expansion cone segments **98**, and the lower retaining sleeve **100**, which are rigidly attached to the float shoe adaptor, to also be displaced downwardly in the longitudinal direction relative to the lower mandrel **86**, the upper cam assembly **90**, and the upper expansion cone segments **96**. The downward longitudinal displacement of the lower cam assembly **92** relative to the upper expansion cone segments **96** causes the upper expansion cone segments to slide down the conical external surfaces **92cbb** of the lower cam assembly and thereby pivot inwardly in the radial direction about the internal flange **94d** of the upper retaining sleeve **94**. The downward longitudinal displacement of the lower expansion cone segments **98** relative to the upper cam assembly **90** causes the lower expansion cone segments **98** to slide down the external conical surfaces **90cbb** of the upper cam assembly and thereby pivot inwardly in the radial direction about the internal flange **100d** of the lower retaining sleeve. As a result of the inward radial movement of the upper and lower expansion cone segments, **96** and **98**, the arcuate external spherical surfaces, **96bb** and **98bb**, of the upper and lower expansion cone segments, **96** and **98**, provide outer arcuate expansion surfaces having a smaller diameter.

[0068] The downward longitudinal movement of the retaining sleeve **94** and float shoe adaptor **102** relative to the lower mandrel **86** is stopped when the stop nut **106** impacts the locking dogs **110**. At this point, the apparatus **10** may then be removed from the interior of the expandable tubular member **14**.

[0069] Thus, the apparatus **10** may be removed from the expandable tubular member **14** prior to the complete radial expansion and plastic deformation of the expandable tubular member by controllably collapsing the upper and lower expansion cone segments, **96** and **98**. As a result, the apparatus **10** provides the following benefits: (1) the apparatus is removable when expansion problems are encountered; (2) lower expansion forces are required because the portion of the expandable tubular member **14** between the packer cups, **76** and **80**, and the expansion cone segments is exposed to the expansion fluid pressure; (3) the expansion cone segments can be run down through the expandable tubular member, prior to radial expansion, and then the expansion cone segments can be expanded; (4) the expansion cone segments can be expanded to one diameter for forming a bell portion; and (5) the expansion cone segments can be adjusted to a second diameter for expanding the remainder of the expandable tubular member.

[0070] In another exemplary embodiment, as illustrated in FIGS. **20a-20b**, upward movement of the apparatus **10** causes the expansion cone for the sleeve **60** to completely radially expand the sleeve **62** of the float shoe **32** and a cementing probe **118** is pulled downward until stopped from further movement by the cementing probe locking ring **119**.

As a result of the complete radial expansion of the sleeve, the float shoe is now firmly coupled to the end of the radially expanded tubular member.

[0071] In an exemplary embodiment, as illustrated in FIGS. 21a-21b, the drill pipe 30 is lowered into the wellbore 12 until the cementing probe 118 stabs into the end 120 of the sliding sleeve valve 122 thereby permitting fluidic materials 38 to bypass around the dart or ball 52. As a result, a bypass flow path 124 is now provided for cement or other fluidic materials 38 to flow around the ball 52 or dart.

[0072] In an exemplary embodiment, as illustrated in FIGS. 22a-22b, a hardenable fluidic sealing material 38 such as, for example, cement, may then be injected into the apparatus 10. The cement flows through the interior of the apparatus, through the bypass flow path 124, and out through the float valve 126 into the annulus 128 between the radially expanded tubular member 22 and the wellbore 12. After the cement 38 has been injected into the annulus 128, the float valve 126 prevents the cement from flowing backwards into the apparatus.

[0073] After completing the injection of the cement into the annulus, the drilling pipe 30 is then pulled upwardly out of the wellbore 12 thereby causing the cementing probe 118 to close the sliding sleeve valve 122. The radial expansion and plastic deformation of the expandable tubular member 14 may then be continued by the resumed injection of fluidic material 38 into the apparatus 10. In several alternative embodiments, the continued radial expansion and plastic deformation of the expandable tubular member 14 may be provided by pressurizing the interior of the apparatus 10 below the expansion cone 24 and/or by displacing the expansion cone 24 upwardly using the hydraulic actuator 36.

[0074] After the cement has cured, the float collar 32 may be drilled out and another expandable tubular member may then be radially expanded and plastically deformed within the wellbore with the upper end of the other tubular member overlapping with the lower end of the earlier expanded tubular member. In this manner, a mono diameter wellbore casing may be formed that includes a plurality of radially expanded tubular members.

[0075] In several alternative embodiments, Guiberson™ cup seals may be added above the expansion cone that provide a fluid tight seal between the drill pipe and the interior surface of the expandable tubular member. In this manner, in the alternative embodiment, the fluid pressure below the cup seals pulls the expansion cone upwardly through the expandable tubular member.

[0076] In several alternative embodiments, the expandable adjustable expansion cone assembly having two adjustable expansion diameters may be replaced with two separate adjustable cones one adjustable to a diameter corresponding to the desired bell portion diameter, and the other adjustable to a diameter corresponding to the desired diameter of the mono diameter casing.

[0077] In several alternative embodiments, the expandable adjustable expansion cone assembly having two adjustable expansion diameters may be replaced with an adjustable cone that is adjustable to a diameter corresponding to the desired bell portion diameter, and a non-adjustable cone having a fixed diameter corresponding to the desired diameter of the mono diameter casing.

[0078] In several alternative embodiments, a conventional rotary expansion device, a conventional compliant expansion device, and/or a conventional hydroforming expansion device may be used instead of, or in combination with, the expansion cone assembly 16.

[0079] In several alternative embodiments, one or more of the conventional commercially available expansion devices available from Weatherford International, Baker Hughes, Halliburton Energy Services, Schlumberger, and/or Enventure Global Technology may be used instead of, or in combination with, the expansion cone assembly 16.

[0080] There has been disclosed in the several embodiments, an apparatus for radially expanding and plastically deforming an expandable tubular member from an initial inside diameter to a desired diameter of a mono diameter wellbore casing. The apparatus includes an upper tubular support member defining a first passage, one or more cup seals coupled to the exterior surface of the upper tubular support member for sealing an interface between the upper tubular support member and the expandable tubular member, an expansion cone assembly coupled to the upper tubular support member adjustable to one expansion diameter corresponding to the desired diameter of the bell portion of the wellbore casing for forming an expanded bell portion in the expandable tubular member and adjustable to another expansion diameter corresponding to the desired diameter of the mono diameter casing for forming the mono diameter wellbore casing, means for actuating the expandable tubular member to adjust from the one diameter to the other diameter, and an actuator for moving the cone through the expandable tubular member a desired distance with the expansion cone assembly adjusted to the diameter of the bell portion and for moving the expansion cone assembly through the expandable tubular member for another distance with the expansion cone assembly adjusted to the desired diameter of the mono diameter portion of the expandable tubular member.

[0081] In one embodiment the expansion cone assembly includes one adjustable cone having an external surface adjustable to the diameter of the bell portion of the expandable tubular member; and wherein the external surface of the one adjustable cone is also adjustable to the diameter corresponding to the desired diameter of the mono diameter wellbore casing.

[0082] In another embodiment the expansion cone assembly includes a first adjustable cone having an external surface adjustable to the diameter of the bell portion of the expandable tubular member and a second adjustable cone having an external surface adjustable to the diameter corresponding to the desired diameter of the mono diameter wellbore casing.

[0083] In another embodiment the expansion cone assembly includes a first adjustable cone having an external surface adjustable to the diameter of the bell portion of the expandable tubular member and collapsible after expanding the bell portion and a second cone having a fixed diameter corresponding to the desired diameter of the mono diameter wellbore casing such that collapsing the first cone effectively adjusts the effective expansion diameter to the fixed diameter of the second cone.

[0084] In another embodiment the expansion cone assembly includes an upper cam assembly coupled to the upper

tubular support member includes a tubular base coupled to the upper tubular support member; and a plurality of cam arms extending from the tubular base in a downward longitudinal direction, each cam arm defining an inclined surface, a plurality of upper expansion cone segments interleaved with the cam arms of the upper cam assembly and pivotally coupled to the tubular support member, and each upper expansion segment movable relative to the inclined surface of one of the plurality of cam arms to adjust the radial position of an external surface of the segment to adjust the diameter of the expansion cone assembly, a lower tubular support member defining a second passage fluidically coupled to the first passage releasably coupled to the upper tubular support member, a lower cam assembly coupled to the lower tubular support member including a tubular base coupled to the lower tubular support member and a plurality of cam arms extending from the tubular base in an upward longitudinal direction, each cam arm defining an inclined surface that mates with the inclined surface of a corresponding one of the upper expansion cone segments, wherein the cam arms of the upper cam assembly are interleaved with and overlap the cam arms of the lower cam assembly; and a plurality of lower expansion cone segments interleaved with cam arms of the lower cam assembly, each lower expansion cone segment pivotally coupled to the lower tubular support member and mating with the inclined surface of a corresponding one of the cam arms of the upper cam assembly and each lower expansion segment movable relative to the inclined surface of one of the plurality of cam arms to adjust the radial position of an external surface of the segment to adjust the diameter of the expansion cone assembly, wherein the lower expansion cone segments interleave and overlap the upper expansion cone segments and wherein the upper and lower expansion cone segments each approximate an arcuate spherical external surface for plastically deforming and radially expanding the expandable tubular member.

[0085] In another embodiment, an apparatus for radially expanding and plastically deforming an expandable tubular member, is disclosed including a tubular support member, a adjustable expansion cone assembly coupled to the tubular support member, an expandable tubular member coupled to the adjustable expansion cone assembly, means for displacing the adjustable expansion cone assembly relative to the expandable tubular member and means for adjusting the adjustable expansion cone assembly from one effective expansion diameter to another effective expansion diameter.

[0086] In another embodiment the tubular support member includes an upper tubular support member comprising an internal flange and a lower tubular support member comprising an internal flange, wherein the expansion cone includes an upper cam assembly coupled to the upper tubular support member including a tubular base coupled to the upper support member and a plurality of cam arms extending from the tubular base in a downward longitudinal direction, each cam arm defining an inclined surface, a plurality of upper expansion cone segments interleaved with the cam arms of the upper cam assembly and pivotally coupled to the internal flange of the upper tubular support member, a lower cam assembly coupled to the lower tubular support member including a tubular base coupled to the lower tubular support member and a plurality of cam arms extending from the tubular base in an upward longitudinal direction, each cam arm defining an inclined surface that mates with the inclined surface of a corresponding one of the

upper expansion cone segments, wherein the cam arms of the upper cam assembly are interleaved with and overlap the cam arms of the lower cam assembly and a plurality of lower expansion cone segments interleaved with cam arms of the lower cam assembly, each lower expansion cone segment pivotally coupled to the internal flange of the lower tubular support member and mating with the inclined surface of a corresponding one of the cam arms of the upper cam assembly; and wherein the apparatus further includes means for releasably coupling the upper tubular support member to the lower tubular support member and means for limiting movement of the upper tubular support member relative to the lower tubular support member.

[0087] In one alternative embodiment the apparatus for radially expanding and plastically deforming an expandable tubular member further includes means for pivoting the upper expansion cone segments and means for pivoting the lower expansion cone segments.

[0088] In one alternative embodiment the apparatus for radially expanding and plastically deforming an expandable tubular member further includes means for pulling the adjustable expansion cone assembly through the expandable tubular member.

[0089] A adjustable expansion cone assembly is disclosed, that includes an upper cam assembly including a tubular base and a plurality of cam arms extending from the tubular base in a downward longitudinal direction, each cam arm defining an inclined surface, a plurality of upper expansion cone segments interleaved with the cam arms of the upper cam assembly, a lower cam assembly including a tubular base and a plurality of cam arms extending from the tubular base in an upward longitudinal direction, each cam arm defining an inclined surface that mates with the inclined surface of a corresponding one of the upper expansion cone segments, wherein the cam arms of the upper cam assembly are interleaved with and overlap the cam arms of the lower cam assembly, a plurality of lower expansion cone segments interleaved with cam arms of the lower cam assembly, each lower expansion cone segment mating with the inclined surface of a corresponding one of the cam arms of the upper cam assembly, means for moving the upper cam assembly toward or away from the lower expansion cone segments to adjust the radial position of an external surface of the lower expansion cone segments, and means for moving the lower cam assembly toward or away from the upper expansion cone segments to adjust the radial position of an external surface of the upper expansion cone segments.

[0090] In one embodiment of the adjustable expansion cone assembly, the upper and lower expansion cone segments together approximate an arcuate spherical external surface.

[0091] In one embodiment of the adjustable expansion cone assembly, each upper expansion cone segment comprises an inner portion defining an arcuate cylindrical upper surface and arcuate cylindrical lower surfaces, an intermediate portion defining arcuate cylindrical and spherical upper surfaces and an arcuate conical lower surface and an outer portion defining arcuate cylindrical upper and lower surfaces, and wherein each lower expansion cone segment include an inner portion defining an arcuate cylindrical upper surface and arcuate cylindrical lower surfaces, an intermediate portion defining arcuate cylindrical and spheri-

cal upper surfaces and an arcuate conical lower surface and an outer portion defining arcuate cylindrical upper and lower surfaces.

[0092] In one embodiment of the adjustable expansion cone assembly, each upper expansion cone segment is tapered in the longitudinal direction from the intermediate portion to the outer portion and each lower expansion cone segment is tapered in the longitudinal direction from the intermediate portion to the outer portion.

[0093] An embodiment of an apparatus for radially expanding and plastically deforming an expandable tubular member from an initial inside diameter to a desired diameter of a mono diameter wellbore casing is disclosed, including an upper tubular support member defining a first passage, one or more cup seals coupled to the exterior surface of the upper tubular support member for sealing an interface between the upper tubular support member and the expandable tubular member, an expansion assembly coupled to the upper tubular support member adjustable to one expansion diameter corresponding to the desired diameter of the bell portion of the wellbore casing for forming an expanded bell portion in the expandable tubular member and adjustable to another expansion diameter corresponding to the desired diameter of the mono diameter casing for forming the mono diameter wellbore casing, means for actuating the expandable tubular member to adjust from the one diameter to the other diameter and an actuator for moving the expansion assembly through the expandable tubular member a desired distance with the expansion assembly adjusted to the diameter of the bell portion and for moving the expansion assembly through the expandable tubular member for another distance with the expansion assembly adjusted to the desired diameter of the mono diameter portion of the expandable tubular member.

[0094] According to one alternative embodiment of an apparatus for radially expanding and plastically deforming an expandable tubular member from an initial inside diameter to a desired diameter of a mono diameter wellbore casing, the expansion assembly includes an expansion cone device.

[0095] According to another alternative embodiment of an apparatus for radially expanding and plastically deforming an expandable tubular member from an initial inside diameter to a desired diameter of a mono diameter wellbore casing, the expansion assembly comprises a rotary expansion device.

[0096] According to another alternative embodiment of an apparatus for radially expanding and plastically deforming an expandable tubular member from an initial inside diameter to a desired diameter of a mono diameter wellbore casing, the expansion assembly comprises compliant expansion device.

[0097] According to another alternative embodiment of an apparatus for radially expanding and plastically deforming an expandable tubular member from an initial inside diameter to a desired diameter of a mono diameter wellbore casing, the expansion assembly comprises a hydroforming expansion device.

[0098] According to another alternative embodiment of an apparatus for radially expanding and plastically deforming an expandable tubular member from an initial inside diam-

eter to a desired diameter of a mono diameter wellbore casing, the expansion assembly comprises an adjustable expander device that is adjustable to the diameter of the bell portion of the expandable tubular member and wherein the one adjustable expander device is also adjustable to the diameter corresponding to the desired diameter of the mono diameter wellbore casing.

[0099] According to another alternative embodiment of an apparatus for radially expanding and plastically deforming an expandable tubular member from an initial inside diameter to a desired diameter of a mono diameter wellbore casing, the expansion assembly comprises an adjustable expander device that is adjustable to the diameter of the bell portion of the expandable tubular member and wherein the one adjustable expander device is also adjustable to the diameter corresponding to the desired diameter of the mono diameter wellbore casing and wherein the adjustable expander device comprises an adjustable expansion cone device

[0100] According to another alternative embodiment of an apparatus for radially expanding and plastically deforming an expandable tubular member from an initial inside diameter to a desired diameter of a mono diameter wellbore casing, the expansion assembly comprises an adjustable expander device that is adjustable to the diameter of the bell portion of the expandable tubular member and wherein the one adjustable expander device is also adjustable, to the diameter corresponding to the desired diameter of the mono diameter wellbore casing and wherein the adjustable expander device includes an adjustable rotary expansion device.

[0101] According to another alternative embodiment of an apparatus for radially expanding and plastically deforming an expandable tubular member from an initial inside diameter to a desired diameter of a mono diameter wellbore casing, the expansion assembly comprises an adjustable expander device that is adjustable to the diameter of the bell portion of the expandable tubular member and wherein the one adjustable expander device is also adjustable to the diameter corresponding to the desired diameter of the mono diameter wellbore casing and wherein the adjustable expander device includes an adjustable compliant expansion device.

[0102] According to another alternative embodiment of an apparatus for radially expanding and plastically deforming an expandable tubular member from an initial inside diameter to a desired diameter of a mono diameter wellbore casing, the expansion assembly comprises an adjustable expander device that is adjustable to the diameter of the bell portion of the expandable tubular member and wherein the one adjustable expander device is also adjustable to the diameter corresponding to the desired diameter of the mono diameter wellbore casing and wherein the adjustable expander device includes an adjustable hydroforming expansion device.

[0103] According to another alternative embodiment of an apparatus for radially expanding and plastically deforming an expandable tubular member from an initial inside diameter to a desired diameter of a mono diameter wellbore casing, wherein the expansion assembly includes a first adjustable expander device adjustable to the diameter of the bell portion of the expandable tubular member and second

adjustable expander device adjustable to the diameter corresponding to the desired diameter of the mono diameter wellbore casing.

**[0104]** According to another alternative embodiment of an apparatus for radially expanding and plastically deforming an expandable tubular member from an initial inside diameter to a desired diameter of a mono diameter wellbore casing, wherein the expansion assembly includes a first adjustable expander device adjustable to the diameter of the bell portion of the expandable tubular member and collapsible after expanding the bell portion and a second expander device having a fixed diameter corresponding to the desired diameter of the mono diameter wellbore casing such that collapsing the first adjustable expander device effectively adjusts the effective expansion diameter to the fixed diameter of the second expander device.

**[0105]** A method of forming a mono diameter casing in a wellbore is disclosed, including supporting a first expandable tubular member in the wellbore using a tubular support member and an adjustable expansion assembly having a first diameter smaller than the inside diameter of the expandable tubular member injecting a fluidic material into the tubular support member, sensing the operating pressure of the injected fluidic material within a first interior portion of the tubular support member, displacing the adjustable expansion assembly relative to the expandable tubular member and into the wellbore when the sensed operating pressure of the injected fluidic material exceeds a predetermined level within the first interior portion of the tubular support member, sensing the operating pressure of the injected fluidic material within a second interior portion of the tubular support member, adjusting the effective expansion diameter of the adjustable expansion assembly to a second diameter larger than the inside diameter of the expandable tubular member when the sensed operating pressure of the injected fluidic material exceeds a predetermined level within the second interior portion of the tubular support member, moving the adjustable expansion assembly having the second diameter a predetermined distance into the expandable tubular member to radially expand and plastically deform a first portion of the expandable tubular member, activating the effective expansion diameter of the adjustable expansion assembly to adjust to a second diameter smaller than the first effective expansion diameter and moving the adjustable expansion assembly through the expandable tubular member when the adjustable expansion assembly is adjusted to the third diameter, to thereby radially expand and plastically deform the remaining portion of the expandable tubular member.

**[0106]** In an alternative embodiment, the method of forming a mono diameter wellbore casing as in the paragraph above that further includes supporting a second expandable tubular member in the wellbore using a tubular support member and an adjustable expansion assembly having a first diameter smaller than the inside diameter of the expandable tubular member, positioning the second expandable tubular member in the expanded first expandable tubular member with the first portion thereof overlapping the second expandable tubular member, injecting a fluidic material into the tubular support member, sensing the operating pressure of the injected fluidic material within a first interior portion of the tubular support member, displacing the adjustable expansion assembly relative to the second expandable tubu-

lar member and into the wellbore when the sensed operating pressure of the injected fluidic material exceeds a predetermined level within the first interior portion of the tubular support member, sensing the operating pressure of the injected fluidic material within a second interior portion of the tubular support member, adjusting the effective expansion diameter of the adjustable expansion assembly to the second diameter when the sensed operating pressure of the injected fluidic material exceeds a predetermined level within the second interior portion of the tubular support member, moving the adjustable expansion assembly having the second diameter a predetermined distance into the second expandable tubular member to radially expand and plastically deform a first portion of the second expandable tubular member below the first portion of the first expandable tubular member, activating the effective expansion diameter of the adjustable expansion assembly to adjust to the second diameter and moving the adjustable expansion assembly through the second expandable tubular member and past the portion overlapping with the first expandable tubular member when the adjustable expansion assembly is adjusted to the third diameter, and to thereby radially expand and plastically deform a second portion of the second expandable tubular member to the same diameter as the expanded remaining portion of the first expandable tubular member.

**[0107]** In an alternative embodiment the method includes expanding the expandable tubular member using an adjustable expansion cone device

**[0108]** In an alternative embodiment the method includes expanding the expandable tubular member using an adjustable rotary expansion device.

**[0109]** In an alternative embodiment the method includes expanding the expandable tubular member using an adjustable compliant expansion device.

**[0110]** In an alternative embodiment the method includes expanding the expandable tubular member using an adjustable hydroforming expansion device.

**[0111]** In an alternative embodiment a method of a casing in a wellbore, includes inserting an expandable tubular member into the wellbore, radially expanding and plastically deforming a lower portion of the expandable tubular member to a first inside diameter; and radially expanding and plastically deforming an upper portion of the expandable tubular member to a second inside diameter, wherein the first inside diameter is larger than the second inside diameter.

**[0112]** In an alternative embodiment the method of forming a casing in a wellbore, as described in the preceding paragraph, further includes inserting a second expandable tubular member into the expanded expandable tubular member so that a top portion of the second expandable tubular member is overlapped by the expanded lower portion of the expanded expandable tubular member and expanding the top portion of the second expandable tubular member to the second diameter of so that the top portion of the second expandable tubular member is expanded radially outward in the lower portion of the expanded expandable tubular member.

**[0113]** In an alternative embodiment of the method of forming a casing in a wellbore, expanding the lower and



upper portions of the expandable tubular members includes expanding using an expansion cone device.

[0114] In an alternative embodiment of the method of forming a casing in a wellbore, expanding the lower and upper portions of the expandable tubular members includes expanding using a rotary expansion device.

[0115] In an alternative embodiment of the method of forming a casing in a wellbore, expanding the lower and upper portions of the expandable tubular members includes expanding using a compliant expansion device.

[0116] In an alternative embodiment of the method of forming a casing in a wellbore, expanding the lower and upper portions of the expandable tubular members includes expanding using a hydroforming expansion device.

[0117] An alternative embodiment of the method of forming a mono diameter casing in a wellbore includes supporting a first expandable tubular member in the wellbore using a tubular support member and an adjustable expansion cone assembly having a first diameter smaller than the inside diameter of the expandable tubular member, injecting a fluidic material into the tubular support member, sensing the operating pressure of the injected fluidic material within a first interior portion of the tubular support member, displacing the adjustable expansion cone assembly relative to the expandable tubular member and into the wellbore when the sensed operating pressure of the injected fluidic material exceeds a predetermined level within the first interior portion of the tubular support member, sensing the operating pressure of the injected fluidic material within a second interior portion of the tubular support member, adjusting the effective expansion diameter of the adjustable expansion cone assembly to a second diameter larger than the inside diameter of the expandable tubular member when the sensed operating pressure of the injected fluidic material exceeds a predetermined level within the second interior portion of the tubular support member, moving the adjustable expansion cone assembly having the second diameter a predetermined distance into the expandable tubular member to radially expand and plastically deform a first portion of the expandable tubular member, activating the effective expansion diameter of the adjustable expansion cone assembly to adjust to a second diameter smaller than the first effective expansion diameter and moving the adjustable expansion cone assembly through the expandable tubular member when the adjustable expansion cone assembly is adjusted to the third diameter, to thereby radially expand and plastically deform the remaining portion of the expandable tubular member.

[0118] In an alternative embodiment of the method of forming a mono diameter casing in a wellbore, as described in the preceding paragraph, further includes supporting a second expandable tubular member in the wellbore using a tubular support member and an adjustable expansion cone assembly having a first diameter smaller than the inside diameter of the expandable tubular member, positioning the second expandable tubular member in the expanded first expandable tubular member with the first portion thereof overlapping the second expandable tubular member, injecting a fluidic material into the tubular support member, sensing the operating pressure of the injected fluidic material within a first interior portion of the tubular support member, displacing the adjustable expansion cone assembly relative

to the second expandable tubular member and into the wellbore when the sensed operating pressure of the injected fluidic material exceeds a predetermined level within the first interior portion of the tubular support member, sensing the operating pressure of the injected fluidic material within a second interior portion of the tubular support member, adjusting the effective expansion diameter of the adjustable expansion cone assembly to the second diameter when the sensed operating pressure of the injected fluidic material exceeds a predetermined level within the second interior portion of the tubular support member, moving the adjustable expansion cone assembly having the second diameter a predetermined distance into the second expandable tubular member to radially expand and plastically deform a first portion of the second expandable tubular member below the first portion of the first expandable tubular member, activating the effective expansion diameter of the adjustable expansion cone assembly to adjust to the second diameter and moving the adjustable expansion cone assembly through the second expandable tubular member and past the portion overlapping with the first expandable tubular member when the adjustable expansion cone assembly is adjusted to the third diameter, and to thereby radially expand and plastically deform a second portion of the second expandable tubular member to the same diameter as the expanded remaining portion of the first expandable tubular member.

[0119] It is understood that variations may be made in the foregoing without departing from the scope of the invention. For example, the teachings of the present illustrative embodiments may be used to provide a wellbore casing, a pipeline, or a structural support.

[0120] Although illustrative embodiments of the invention have been shown and described, a wide range of modification, changes and substitution is contemplated in the foregoing disclosure. In some instances, some features of the present invention may be employed without a corresponding use of the other features. Accordingly, it is appropriate that the appended claims be construed broadly and in a manner consistent with the scope of the invention.

What is claimed is:

1. An apparatus for radially expanding and plastically deforming an expandable tubular member from an initial inside diameter to a desired diameter of a mono diameter wellbore casing, comprising:

an upper tubular support member defining a first passage;

one or more cup seals coupled to the exterior surface of the upper tubular support member for sealing an interface between the upper tubular support member and the expandable tubular member;

an expansion cone assembly coupled to the upper tubular support member adjustable to one expansion diameter corresponding to the desired diameter of the bell portion of the wellbore casing for forming an expanded bell portion in the expandable tubular member and adjustable to another expansion diameter corresponding to the desired diameter of the mono diameter casing for forming the mono diameter wellbore casing;

means for actuating the expandable tubular member to adjust from the one diameter to the other diameter; and

- an actuator for moving the cone through the expandable tubular member a desired distance with the expansion cone assembly adjusted to the diameter of the bell portion and for moving the expansion cone assembly through the expandable tubular member for another distance with the expansion cone assembly adjusted to the desired diameter of the mono diameter portion of the expandable tubular member.
- 2.** The apparatus of claim 1, wherein
- the expansion cone assembly comprises a one adjustable cone having an external surface adjustable to the diameter of the bell portion of the expandable tubular member; and wherein
- the external surface of the one adjustable cone is also adjustable to the diameter corresponding to the desired diameter of the mono diameter wellbore casing.
- 3.** The apparatus of claim 1, wherein the expansion cone assembly comprises:
- a first adjustable cone having an external surface adjustable to the diameter of the bell portion of the expandable tubular member; and
  - a second adjustable cone having an external surface adjustable to the diameter corresponding to the desired diameter of the mono diameter wellbore casing.
- 4.** The apparatus of claim 1, wherein the expansion cone assembly comprises:
- a first adjustable cone having an external surface adjustable to the diameter of the bell portion of the expandable tubular member and collapsible after expanding the bell portion; and
  - a second cone having a fixed diameter corresponding to the desired diameter of the mono diameter wellbore casing such that collapsing the first cone effectively adjusts the effective expansion diameter to the fixed diameter of the second cone.
- 5.** The apparatus of claim 1, wherein the expansion cone assembly comprises:
- an upper cam assembly coupled to the upper tubular support member comprising:
    - a tubular base coupled to the upper tubular support member; and
    - a plurality of cam arms extending from the tubular base in a downward longitudinal direction, each cam arm defining an inclined surface;
  - a plurality of upper expansion cone segments interleaved with the cam arms of the upper cam assembly and pivotally coupled to the tubular support member, and each upper expansion segment movable relative to the inclined surface of one of the plurality of cam arms to adjust the radial position of an external surface of the segment to adjust the diameter of the expansion cone assembly;
  - a lower tubular support member defining a second passage fluidically coupled to the first passage releasably coupled to the upper tubular support member;
  - a lower cam assembly coupled to the lower tubular support member comprising:
    - a tubular base coupled to the lower tubular support member; and
    - a plurality of cam arms extending from the tubular base in an upward longitudinal direction, each cam arm defining an inclined surface that mates with the inclined surface of a corresponding one of the upper expansion cone segments;
  - wherein the cam arms of the upper cam assembly are interleaved with and overlap the cam arms of the lower cam assembly; and
  - a plurality of lower expansion cone segments interleaved with cam arms of the lower cam assembly, each lower expansion cone segment pivotally coupled to the lower tubular support member and mating with the inclined surface of a corresponding one of the cam arms of the upper cam assembly and each lower expansion segment movable relative to the inclined surface of one of the plurality of cam arms to adjust the radial position of an external surface of the segment to adjust the diameter of the expansion cone assembly;
  - wherein the lower expansion cone segments interleave and overlap the upper expansion cone segments; and
  - wherein the upper and lower expansion cone segments each approximate an arcuate spherical external surface for plastically deforming and radially expanding the expandable tubular member.
- 6.** An apparatus for radially expanding and plastically deforming an expandable tubular member, comprising:
- a tubular support member;
  - a adjustable expansion cone assembly coupled to the tubular support member;
  - an expandable tubular member coupled to the adjustable expansion cone assembly;
  - means for displacing the adjustable expansion cone assembly relative to the expandable tubular member; and
  - means for adjusting the adjustable expansion cone assembly from one effective expansion diameter to another effective expansion diameter.
- 7.** The apparatus of claim 6, wherein the tubular support member comprises an upper tubular support member comprising an internal flange and a lower tubular support member comprising an internal flange; wherein the expansion cone comprises:
- an upper cam assembly coupled to the upper tubular support member comprising:
    - a tubular base coupled to the upper support member; and
    - a plurality of cam arms extending from the tubular base in a downward longitudinal direction, each cam arm defining an inclined surface;
  - a plurality of upper expansion cone segments interleaved with the cam arms of the upper cam assembly and pivotally coupled to the internal flange of the upper tubular support member;

a lower cam assembly coupled to the lower tubular support member comprising:

a tubular base coupled to the lower tubular support member; and

a plurality of cam arms extending from the tubular base in an upward longitudinal direction, each cam arm defining an inclined surface that mates with the inclined surface of a corresponding one of the upper expansion cone segments;

wherein the cam arms of the upper cam assembly are interleaved with and overlap the cam arms of the lower cam assembly; and

a plurality of lower expansion cone segments interleaved with cam arms of the lower cam assembly, each lower expansion cone segment pivotally coupled to the internal flange of the lower tubular support member and mating with the inclined surface of a corresponding one of the cam arms of the upper cam assembly; and wherein the apparatus further comprises:

means for releasably coupling the upper tubular support member to the lower tubular support member; and

means for limiting movement of the upper tubular support member relative to the lower tubular support member.

**8.** The apparatus of claim 6, further comprising:

means for pivoting the upper expansion cone segments; and

means for pivoting the lower expansion cone segments.

**9.** The apparatus of claim 6, further comprising:

means for pulling the adjustable expansion cone assembly through the expandable tubular member.

**10.** A adjustable expansion cone assembly, comprising:

an upper cam assembly comprising:

a tubular base; and

a plurality of cam arms extending from the tubular base in a downward longitudinal direction, each cam arm defining an inclined surface;

a plurality of upper expansion cone segments interleaved with the cam arms of the upper cam assembly;

a lower cam assembly comprising:

a tubular base; and

a plurality of cam arms extending from the tubular base in an upward longitudinal direction, each cam arm defining an inclined surface that mates with the inclined surface of a corresponding one of the upper expansion cone segments;

wherein the cam arms of the upper cam assembly are interleaved with and overlap the cam arms of the lower cam assembly;

a plurality of lower expansion cone segments interleaved with cam arms of the lower cam assembly, each lower expansion cone segment mating with the inclined surface of a corresponding one of the cam arms of the upper cam assembly;

means for moving the upper cam assembly toward or away from the lower expansion cone segments to adjust the radial position of an external surface of the lower expansion cone segments; and

means for moving the lower cam assembly toward or away from the upper expansion cone segments to adjust the radial position of an external surface of the upper expansion cone segments.

**11.** The apparatus of claim 10, wherein the upper and lower expansion cone segments together approximate an arcuate spherical external surface.

**12.** The apparatus of claim 10, wherein each upper expansion cone segment comprises:

an inner portion defining an arcuate cylindrical upper surface and arcuate cylindrical lower surfaces;

an intermediate portion defining arcuate cylindrical and spherical upper surfaces and an arcuate conical lower surface; and

an outer portion defining arcuate cylindrical upper and lower surfaces; and

wherein each lower expansion cone segment comprises:

an inner portion defining an arcuate cylindrical upper surface and arcuate cylindrical lower surfaces;

an intermediate portion defining arcuate cylindrical and spherical upper surfaces and an arcuate conical lower surface; and

an outer portion defining arcuate cylindrical upper and lower surfaces.

**13.** The apparatus of claim 12, wherein each upper expansion cone segment is tapered in the longitudinal direction from the intermediate portion to the outer portion; and

wherein each lower expansion cone segment is tapered in the longitudinal direction from the intermediate portion to the outer portion.

**14.** An apparatus for radially expanding and plastically deforming an expandable tubular member from an initial inside diameter to a desired diameter of a mono diameter wellbore casing, comprising:

an upper tubular support member defining a first passage;

one or more cup seals coupled to the exterior surface of the upper tubular support member for sealing an interface between the upper tubular support member and the expandable tubular member;

an expansion assembly coupled to the upper tubular support member adjustable to one expansion diameter corresponding to the desired diameter of the bell portion of the wellbore casing for forming an expanded bell portion in the expandable tubular member and adjustable to another expansion diameter corresponding to the desired diameter of the mono diameter casing for forming the mono diameter wellbore casing;

means for actuating the expandable tubular member to adjust from the one diameter to the other diameter; and

an actuator for moving the expansion assembly through the expandable tubular member a desired distance with the expansion assembly adjusted to the diameter of the bell portion and for moving the expansion assembly

through the expandable tubular member for another distance with the expansion assembly adjusted to the desired diameter of the mono diameter portion of the expandable tubular member.

15. The apparatus of claim 14, wherein the expansion assembly comprises a expansion cone device

16. The apparatus of claim 14, wherein the expansion assembly comprises a rotary expansion device.

17. The apparatus of claim 14, wherein the expansion assembly comprises compliant expansion device.

18. The apparatus of claim 14, wherein the expansion assembly comprises a hydroforming expansion device.

19. The apparatus of claim 14, wherein:

the expansion assembly comprises an adjustable expander device having adjustable to the diameter of the bell portion of the expandable tubular member; and wherein

the one adjustable expander device is also adjustable to the diameter corresponding to the desired diameter of the mono diameter wellbore casing.

20. The apparatus of claim 19, wherein the adjustable expander device comprises an adjustable expansion cone device

21. The apparatus of claim 19, wherein the adjustable expander device comprises an adjustable rotary expansion device.

22. The apparatus of claim 19, wherein the adjustable expander device comprises an adjustable compliant expansion device.

23. The apparatus of claim 19, wherein the adjustable expander device comprises an adjustable hydroforming expansion device.

25. The apparatus of claim 14, wherein the expansion assembly comprises:

a first adjustable expander device adjustable to the diameter of the bell portion of the expandable tubular member; and

a second adjustable expander device adjustable to the diameter corresponding to the desired diameter of the mono diameter wellbore casing.

26. The apparatus of claim 14, wherein the expansion assembly comprises:

a first adjustable expander device adjustable to the diameter of the bell portion of the expandable tubular member and collapsible after expanding the bell portion; and

a second expander device having a fixed diameter corresponding to the desired diameter of the mono diameter wellbore casing such that collapsing the first adjustable expander device effectively adjusts the effective expansion diameter to the fixed diameter of the second expander device.

27. A method of forming a mono diameter casing in a wellbore, comprising:

supporting a first expandable tubular member in the wellbore using a tubular support member and an adjustable expansion assembly having a first diameter smaller than the inside diameter of the expandable tubular member;

injecting a fluidic material into the tubular support member;

sensing the operating pressure of the injected fluidic material within a first interior portion of the tubular support member;

displacing the adjustable expansion assembly relative to the expandable tubular member and into the wellbore when the sensed operating pressure of the injected fluidic material exceeds a predetermined level within the first interior portion of the tubular support member;

sensing the operating pressure of the injected fluidic material within a second interior portion of the tubular support member;

adjusting the effective expansion diameter of the adjustable expansion assembly to a second diameter larger than the inside diameter of the expandable tubular member when the sensed operating pressure of the injected fluidic material exceeds a predetermined level within the second interior portion of the tubular support member;

moving the adjustable expansion assembly having the second diameter a predetermined distance into the expandable tubular member to radially expand and plastically deform a first portion of the expandable tubular member;

activating the effective expansion diameter of the adjustable expansion assembly to adjust to a second diameter smaller than the first effective expansion diameter; and

moving the adjustable expansion assembly through the expandable tubular member when the adjustable expansion assembly is adjusted to the third diameter, to thereby radially expand and plastically deform the remaining portion of the expandable tubular member.

28. The method of forming a mono diameter wellbore casing as in claim 27 further comprising:

supporting a second expandable tubular member in the wellbore using a tubular support member and an adjustable expansion assembly having a first diameter smaller than the inside diameter of the expandable tubular member;

positioning the second expandable tubular member in the expanded first expandable tubular member with the first portion thereof overlapping the second expandable tubular member;

injecting a fluidic material into the tubular support member;

sensing the operating pressure of the injected fluidic material within a first interior portion of the tubular support member;

displacing the adjustable expansion assembly relative to the second expandable tubular member and into the wellbore when the sensed operating pressure of the injected fluidic material exceeds a predetermined level within the first interior portion of the tubular support member;

sensing the operating pressure of the injected fluidic material within a second interior portion of the tubular support member;

adjusting the effective expansion diameter of the adjustable expansion assembly to the second diameter when

the sensed operating pressure of the injected fluidic material exceeds a predetermined level within the second interior portion of the tubular support member;

moving the adjustable expansion assembly having the second diameter a predetermined distance into the second expandable tubular member to radially expand and plastically deform a first portion of the second expandable tubular member below the first portion of the first expandable tubular member;

activating the effective expansion diameter of the adjustable expansion assembly to adjust to the second diameter; and

moving the adjustable expansion assembly through the second expandable tubular member and past the portion overlapping with the first expandable tubular member when the adjustable expansion assembly is adjusted to the third diameter, and to thereby radially expand and plastically deform a second portion of the second expandable tubular member to the same diameter as the expanded remaining portion of the first expandable tubular member.

**29.** The method of claim 27, wherein the adjustable expansion assembly comprises an adjustable expansion cone device

**30.** The apparatus of claim 27, wherein the adjustable expansion assembly comprises an adjustable a rotary expansion device.

**31.** The apparatus of claim 27, wherein the adjustable expansion assembly comprises an adjustable compliant expansion device.

**32.** The apparatus of claim 27, wherein the adjustable expansion assembly comprises an adjustable hydroforming expansion device.

**33.** A method of forming a casing in a wellbore, comprising:

inserting an expandable tubular member into the wellbore radially expanding and plastically deforming a lower portion of the expandable tubular member to a first inside diameter; and

radially expanding and plastically deforming an upper portion of the expandable tubular member to a second inside diameter, wherein the first inside diameter is larger than the second inside diameter.

**34.** The method of claim 33 further comprising:

inserting a second expandable tubular member, into the expanded expandable tubular member so that a top portion of the second expandable tubular member is overlapped by the expanded lower portion of the expanded expandable tubular member; and

expanding the top portion of the second expandable tubular member to the second diameter so that the top portion of the second expandable tubular member is expanded radially outward in the expanded lower portion of the expanded expandable tubular member.

**35.** The method of claim 33, wherein the expanding the lower and upper portions of the expandable tubular members comprises expanding using an expansion cone device.

**36.** The method of claim 33, wherein the expanding the lower and upper portions of the expandable tubular members comprises expanding using a rotary expansion device.

**37.** The method of claim 33, wherein the expanding the lower and upper portions of the expandable tubular members comprises expanding using a compliant expansion device.

**38.** The method of claim 33, wherein the expanding the lower and upper portions of the expandable tubular members comprises expanding using a hydroforming expansion device.

**39.** A method of forming a mono diameter casing in a wellbore, comprising:

supporting a first expandable tubular member in the wellbore using a tubular support member and an adjustable expansion cone assembly having a first diameter smaller than the inside diameter of the expandable tubular member;

injecting a fluidic material into the tubular support member;

sensing the operating pressure of the injected fluidic material within a first interior portion of the tubular support member;

displacing the adjustable expansion cone assembly relative to the expandable tubular member and into the wellbore when the sensed operating pressure of the injected fluidic material exceeds a predetermined level within the first interior portion of the tubular support member;

sensing the operating pressure of the injected fluidic material within a second interior portion of the tubular support member;

adjusting the effective expansion diameter of the adjustable expansion cone assembly to a second diameter larger than the inside diameter of the expandable tubular member when the sensed operating pressure of the injected fluidic material exceeds a predetermined level within the second interior portion of the tubular support member;

moving the adjustable expansion cone assembly having the second diameter a predetermined distance into the expandable tubular member to radially expand and plastically deform a first portion of the expandable tubular member;

activating the effective expansion diameter of the adjustable expansion cone assembly to adjust to a second diameter smaller than the first effective expansion diameter; and

moving the adjustable expansion cone assembly through the expandable tubular member when the adjustable expansion cone assembly is adjusted to the third diameter, to thereby radially expand and plastically deform the remaining portion of the expandable tubular member.

**40.** The method of forming a mono diameter wellbore casing as in claim 39 further comprising:

supporting a second expandable tubular member in the wellbore using a tubular support member and an adjustable expansion cone assembly having a first diameter smaller than the inside diameter of the expandable tubular member;

positioning the second expandable tubular member in the expanded first expandable tubular member with the first portion thereof overlapping the second expandable tubular member;

injecting a fluidic material into the tubular support member;

sensing the operating pressure of the injected fluidic material within a first interior portion of the tubular support member;

displacing the adjustable expansion cone assembly relative to the second expandable tubular member and into the wellbore when the sensed operating pressure of the injected fluidic material exceeds a predetermined level within the first interior portion of the tubular support member;

sensing the operating pressure of the injected fluidic material within a second interior portion of the tubular support member;

adjusting the effective expansion diameter of the adjustable expansion cone assembly to the second diameter when the sensed operating pressure of the injected

fluidic material exceeds a predetermined level within the second interior portion of the tubular support member;

moving the adjustable expansion cone assembly having the second diameter a predetermined distance into the second expandable tubular member to radially expand and plastically deform a first portion of the second expandable tubular member below the first portion of the first expandable tubular member;

activating the effective expansion diameter of the adjustable expansion cone assembly to adjust to the second diameter; and

moving the adjustable expansion cone assembly through the second expandable tubular member and past the portion overlapping with the first expandable tubular member when the adjustable expansion cone assembly is adjusted to the third diameter, and to thereby radially expand and plastically deform a second portion of the second expandable tubular member to the same diameter as the expanded remaining portion of the first expandable tubular member.

\* \* \* \* \*