

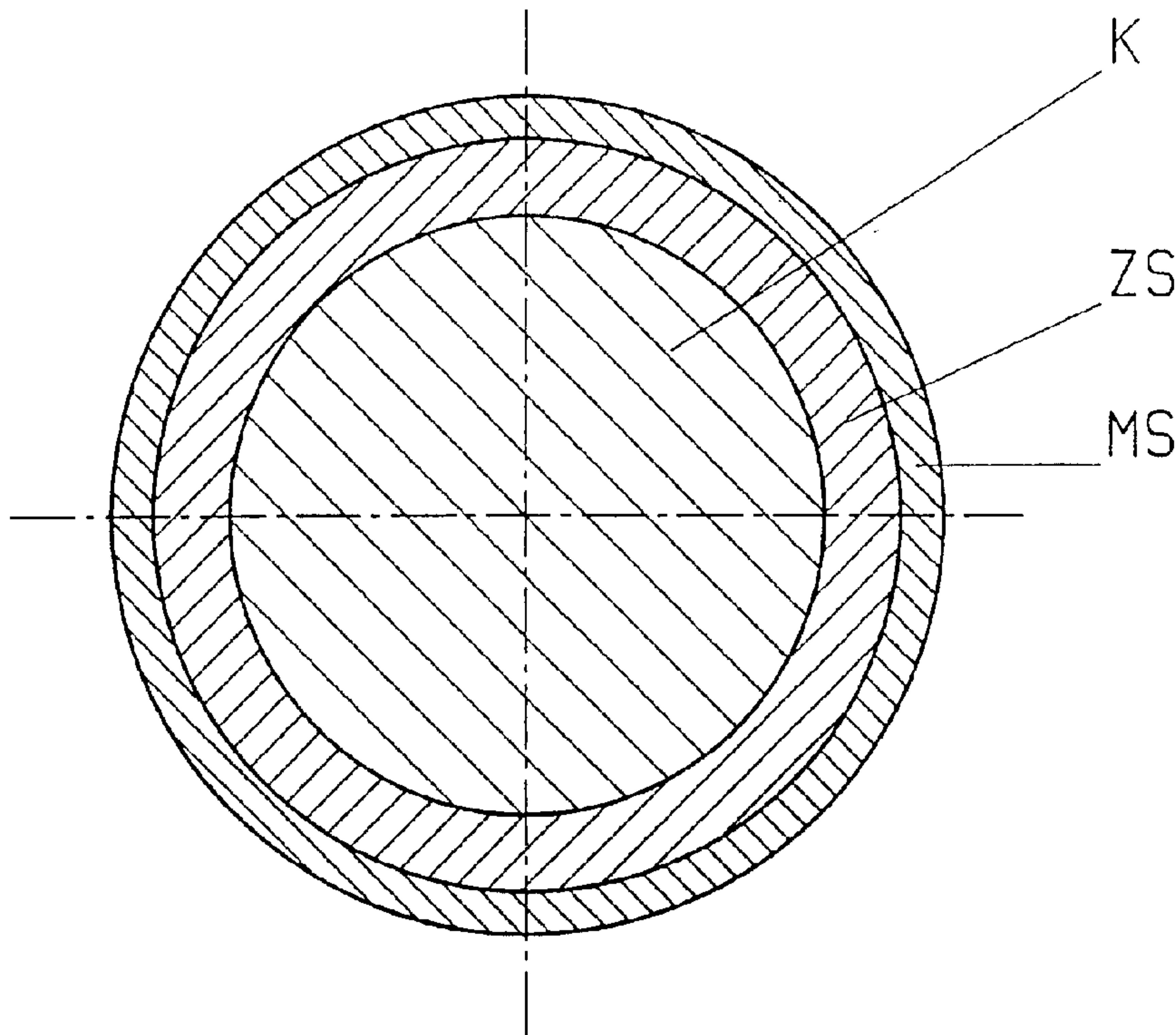

(86) Date de dépôt PCT/PCT Filing Date: 1997/08/22  
 (87) Date publication PCT/PCT Publication Date: 1998/03/12  
 (45) Date de délivrance/Issue Date: 2005/08/09  
 (85) Entrée phase nationale/National Entry: 1999/03/03  
 (86) N° demande PCT/PCT Application No.: EP 1997/004595  
 (87) N° publication PCT/PCT Publication No.: 1998/009764  
 (30) Priorité/Priority: 1996/09/04 (196 35 775.6) DE

(51) Cl.Int.<sup>6</sup>/Int.Cl.<sup>6</sup> B23H 7/08  
 (72) Inventeurs/Inventors:  
 BARTHEL, BERND, DE;  
 GROOS, HEINRICH, DE;  
 HERMANNI, HANS, DE;  
 TAUBER, KLAUS, DE  
 (73) Propriétaire/Owner:  
 BERKENHOFF GMBH, DE  
 (74) Agent: FETHERSTONHAUGH & CO.

(54) Titre : ELECTRODE D'EROSION DE FORTE INTENSITE  
 (54) Title: HIGH-STRENGTH EROSION ELECTRODE



(57) Abrégé/Abstract:

The invention concerns a high-strength erosion electrode having good electrical conductivity. Said erosion electrode comprises a steel core, an intermediate layer of copper or a copper-containing alloy, and an outer layer containing at least 40 % zinc. The steel core comprises a patented structure which contains between 0.6 and 1 wt.% carbon and occupies an area of the core corresponding to between 50 and 75 % of the erosion electrode diameter, the intermediate layer occupying an area of between 5 and 40 % of the total diameter, the outer layer occupying an area of between 10 and 30 %, and the zinc content of the outer layer being between 40 and 60 wt. %.

## HIGH-STRENGTH EROSION ELECTRODE

## ABSTRACT OF THE DISCLOSURE

The invention concerns a high-strength erosion  
5 electrode having good electrical conductivity. Said  
erosion electrode comprises a steel core, an intermediate  
layer of copper or a copper-containing alloy, and an  
outer layer containing at least 40 % zinc. The steel  
core comprises a patented structure which contains  
10 between 0.6 and 1 wt.% carbon and occupies an area of the  
core corresponding to between 50 and 75 % of the erosion  
electrode diameter, the intermediate layer occupying an  
area of between 5 and 40 % of the total diameter, the  
outer layer occupying an area of between 10 and 30 %, and  
15 the zinc content of the outer layer being between 40 and  
60 wt.%.

~~THIS IS A~~  
~~TRANSLAT.~~

## HIGH-STRENGTH EROSION ELECTRODE

### Description:

5 The invention relates to a method for the  
manufacture of a wire electrode for the spark-erosion  
process and a wire electrode for this method, which  
consists of a core of steel, an intermediate layer of  
copper or a high copper-containing alloy, and an outer  
layer with at least 40 % zinc.

10 Wire electrodes, which are designed with multiple  
layers, which have a core of steel, an intermediate layer  
of copper arranged around the core, and an outer zinc-  
containing layer, are known, for example, from the  
DE-PS 29 06 245. All known wire electrodes, which are  
15 constructed with a steel core, do indeed have an  
increased strength compared with copper or brass  
electrodes, however, all of these erosion electrodes have  
the disadvantage that if they have comparatively high  
strengths, their electrical conductivity is very low and  
20 merely reaches  $8 \text{ S}\cdot\text{m}/\text{mm}^2$ . This comparatively high  
tensile strength is particularly advantageous for the  
cutting of high or thick workpieces or, however, also for  
the cutting of very small parts since high wire tensions  
are here demanded. However, these known wire electrodes  
25 have the disadvantage that their erosion performance is  
relatively low. In particular, in the case of cutting  
very small parts with erosion-wire diameters of up to  $10 \mu\text{m}$ ,  
high wire strengths are demanded in order to reduce  
deflection and vibration of the wire to a minimum.  
30 Tungsten or molybdenum wires have been used up to now for  
the cutting of very small parts with wire thicknesses of  
 $100 \mu\text{m}$  and less, however, tungsten or molybdenum wires  
are extremely expensive to manufacture. Erosion wires  
with a steel core and a brass outer layer have been  
35 unable to be successful up to now for this purpose since  
they always, in comparison to tungsten wires, showed a  
lesser strength and a poorer erosion behaviour.

.23581-111

The basic purpose of the invention is to provide high-strength erosion electrodes with a core of steel of the abovementioned type and a method for their manufacture, which electrodes have strengths which are 1800 N/mm<sup>2</sup> and  
5 higher and, in addition, have a comparatively high conductivity of 10 S·m/mm<sup>2</sup> and more.

In all with one aspect of the present invention there is provided a method of manufacturing a high-strength erosion electrode having a steel core, an intermediate layer  
10 of a high copper content-containing alloy and an outer layer of an alloy containing at least 40 % zinc, said method comprising the steps of: providing the steel core having a carbon content of from 0.6 to 1 wt.%; applying the intermediate layer of the high copper content-containing  
15 alloy onto the steel core; applying the outer layer of zinc or a high zinc content-containing alloy onto the intermediate layer to form a wire electrode; performing diffusion annealing on the wire electrode for a period of time sufficient to form the outer layer into a zinc-  
20 containing alloy having a melting point higher than the austenitization temperature required for patenting of the steel core; and performing intermediate annealing on the wire electrode under conditions sufficient to subject the wire electrode to a patenting treatment to form the high-  
25 strength erosion electrode.

In all with a further aspect of the invention there is provided an erosion electrode with a core of steel, an intermediate layer of a high copper-containing alloy and an outer layer with at least 40 % zinc, wherein the steel  
30 core has a patented structure with a carbon content of 0.6 to 1 wt.%, which occupies an area of the core of

23581-111

50 to 75 % of the cross-sectional surface of the erosion electrode, the intermediate layer has an area of 5 to 40 % of the cross-sectional area of the erosion electrode and the outer layer has an area of 10 to 30 % of the cross-sectional area of the erosion electrode, and the zinc content of the outer layer lies between 40 and 60 wt.%.

Thus, an erosion wire of the invention has a steel core K with a carbon content of 0.6 to 1 %, whereby a high copper-containing copper alloy is applied as an intermediate layer ZS onto said steel core. This intermediate layer is covered by an outer layer MS which, when the erosion wire is finished, consists of a zinc alloy, the zinc content of which lies between 40 and 60 %. The condition for achieving the comparatively high conductivity of the erosion electrode with an equally high strength is that the core has a patented structure, consists advantageously of sorbite, whereby a further layer is arranged between the outer layer and the core, which further layer contains high amounts of copper, that is, it is only low alloyed. Silver in the form of the alloy CuAgI has here proven to be particularly advantageous as the alloy element. Also a copper alloy with a small amount of zinc can be advantageously utilized for the intended purpose. An outer layer has been applied to this intermediate layer, which outer layer consists of a zinc alloy, in which the zinc content reaches at least 40 % and may reach a maximum of 60 %.

A wire electrode of the invention could be manufactured in such a manner that a sleeve out of a brass pipe or brass band is applied to a steel core enveloped with copper, and the composite is thereafter reduced by means of wire drawing. This type of manufacture becomes more

23581-111

problematic the higher the zinc content in the outer layer is supposed to be. A further method could consist of providing a copper-enveloped

steel wire with a zinc-containing outer layer via a dipping method. The zinc content could here be adjusted at random. The difficulty with this method is to apply the outer layer with an even thickness over the circumference.

A very advantageous method for the manufacture of a wire electrode is that a steel core is enveloped with a copper layer, whereby the structure of the steel core should exist in a patented form. A zinc alloy is thereafter then applied to this copper intermediate layer, whereby in the simplest case the outer layer consists of pure zinc. This is followed by a diffusion annealing, the duration of which is chosen in dependency of the diffusion temperature such that the entire outer layer forms a zinc alloy, the zinc content of which amounts to 60 % at a maximum. The duration of the diffusion annealing is furthermore determined such that the demanded areas for the core wire, the intermediate layer and the outer layer adjust, whereby these areas of the three sections are not only important for the strength achieved in the final wire but also for its conductivity. A further decisive factor for the strength, however, also for the conductivity of the erosion wire is that in the final wire the core consists of a patented structure, whereby here electrical conductivity and strength are being equally optimized.

The wire, the core of which should already exist in the patented state is, after the diffusion annealing has occurred, reduced to its diameter by drawing.

The area of the core on the electrode should lie between 50 to 75 % of the entire electrode. The area of the intermediate layer should lie between 5 and 40 % and the area of the outer layer between 10 to 30 %. If one furthermore meets the demand that the zinc content of the outer layer lies between 40 and 60, advantageously at slightly above 50 %, then one obtains an electrode with a conductivity which lies between 10 and 18 S·m/mm<sup>2</sup>,

whereby at the same time strengths are obtained which lie between 1800 and 2500 N/mm<sup>2</sup>. It must hereby be noted that the demand for high conductivity and high strength is contrare, namely an inventive wire with a very high strength has a comparatively low electrical conductivity and vice versa. The wires of the invention can be drawn to a diameter of below 10 μm, namely, to diameters which are sufficiently small for the up to now known uses. It has thereby been found to be particularly advantageous that these wires with a thin diameter can easily replace the up to now used tungsten and molybdenum wires and are by comparison significantly less expensive to manufacture, show no aging, have lower raw-material costs, and moreover offer a higher safety in manufacture and have constant erosion characteristics. The achieved quality in manufacture is so great that the wire of the invention will practically not break down on the erosion machine, whereas the breakdown of the up to now utilized molybdenum or tungsten wire amounts to up to 50 %.

The high strength is particularly advantageous in the case of erosion wires with diameters of above 100 μm when workpieces with a greater height are to be cut since high wire tensions are required here in order to keep bending and vibrations low.

An electrode of the invention is distinguished by a high conductivity and a comparatively high strength. Moreover, the cutting quality with a high exactness in contours is very good, whereby this precision is favored by the high wire tension based on the high strength of the wire.

23581-111

CLAIMS:

1. A method of manufacturing a high-strength erosion electrode having a steel core, an intermediate layer of a high copper content-containing alloy and an outer layer of an alloy containing at least 40 % zinc, said method  
5 comprising the steps of:

providing the steel core having a carbon content of from 0.6 to 1 wt.%;

applying the intermediate layer of the high copper  
10 content-containing alloy onto the steel core;

applying the outer layer of zinc or a high zinc content-containing alloy onto the intermediate layer to form a wire electrode;

performing diffusion annealing on the wire  
15 electrode for a period of time sufficient to form the outer layer into a zinc-containing alloy having a melting point higher than the austenitization temperature required for patenting of the steel core; and

performing intermediate annealing on the wire  
20 electrode under conditions sufficient to subject the wire electrode to a patenting treatment to form the high-strength erosion electrode.

2. The method of claim 1, comprising the steps of:

providing a patented steel wire with a copper  
25 intermediate layer as an initial wire;

applying a high zinc content-containing alloy outer layer onto the intermediate layer;

.23581-111

performing diffusion annealing on the wire to form a brass outer layer having a predetermined composition and strength;

deforming the wire to reduce the diameter thereof;

5 and

performing a patenting step after each deformation step until the wire reaches its final diameter.

3. The method according to claim 1 or 2, wherein the outer layer after a first diffusion annealing step has a  
10 zinc content, which does not exceed 60 %.

4. The method according to one of the claims 2 or 3, wherein the initial wire has a core diameter of 0.8 mm and a layer thickness of the intermediate layer of 0.1 mm, that the outer layer applied onto the intermediate layer  
15 is 30  $\mu\text{m}$ , the wire is then subjected to a diffusion annealing at 400°C over 4 hours, and is thereafter drawn to a diameter of approximately 0.4 mm, the erosion wire is thereafter patented and is then drawn under, if necessary, further patentings to its final diameter.

20 5. An erosion electrode with a core of steel, an intermediate layer of a high copper-containing alloy and an outer layer with at least 40 % zinc, wherein the steel core has a patented structure with a carbon content of 0.6 to 1 wt.%, which occupies an area of the core of  
25 50 to 75 % of the cross-sectional surface of the erosion electrode, the intermediate layer has an area of 5 to 40 % of the cross-sectional area of the erosion electrode and the outer layer has an area of 10 to 30 % of the cross-sectional area of the erosion electrode, and the zinc content of the  
30 outer layer lies between 40 and 60 wt.%.

.23581-111

6. The erosion electrode according to claim 5, wherein the conductivity of the erosion electrode is at least  $10 \text{ S}\cdot\text{m}/\text{mm}^2$ .

7. The erosion electrode according to claim 5, wherein the conductivity of the erosion electrode is larger than  $12 \text{ S}\cdot\text{m}/\text{mm}^2$ .

8. The erosion electrode according to any one of claims 5 to 7, wherein the intermediate layer consists of copper with a small amount of silver.

9. The erosion electrode according to claim 8, wherein the intermediate layer consists of CuAgI.

10. The erosion electrode according to any one of claims 5 to 9, characterized in that the strength of the erosion wire is at least  $1800 \text{ N}/\text{mm}^2$ .

11. The erosion electrode according to any one of claims 5 to 9 wherein the strength of the erosion wire is at least  $2000 \text{ N}/\text{mm}^2$ .

FETHERSTONHAUGH & CO.

OTTAWA, CANADA

PATENT AGENTS

1/1

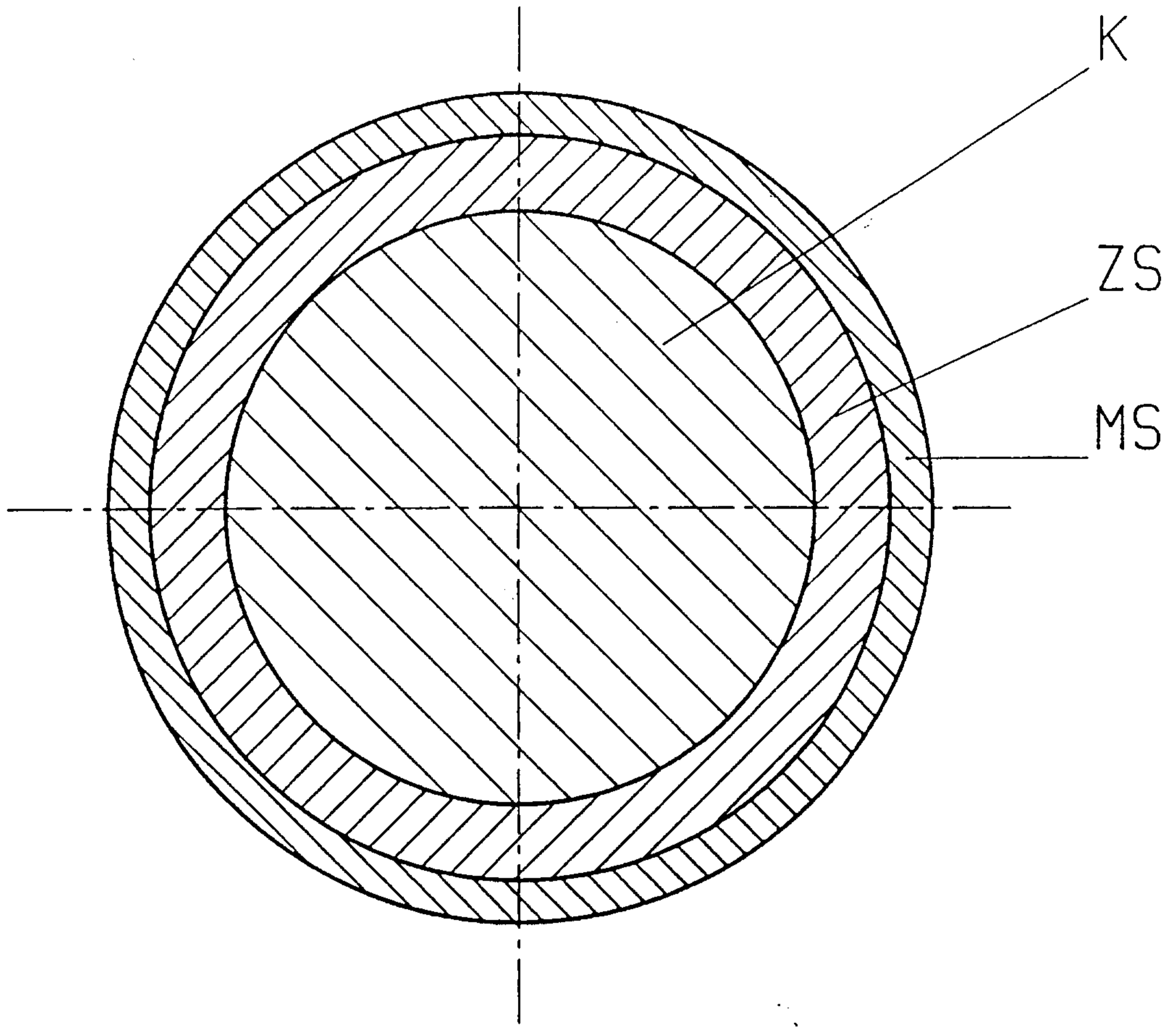

Fig. 1

