



(12) **EUROPEAN PATENT APPLICATION**
 published in accordance with Art. 153(4) EPC

(43) Date of publication:
16.07.2008 Bulletin 2008/29

(51) Int Cl.:
D21F 7/08 (2006.01)

(21) Application number: **06768454.8**

(86) International application number:
PCT/JP2006/316060

(22) Date of filing: **09.08.2006**

(87) International publication number:
WO 2007/018313 (15.02.2007 Gazette 2007/07)

(84) Designated Contracting States:
DE FI FR IT SE

(72) Inventor: **OHUCHI, Takashi**
Tokyo 1130033 (JP)

(30) Priority: **10.08.2005 JP 2005232034**

(74) Representative: **Van Straaten, Joop**
Octroibureau Van Straaten B.V.
Monseigneur Bosstraat 22
5401 EB Uden (NL)

(71) Applicant: **Ichikawa Co., Ltd.**
Tokyo 113-0033 (JP)

(54) **PRESS FELT FOR PAPERMAKING**

(57) Press felt 10 comprises a base body 20 and batt layers 30 which are needled together. The batt layers 30 comprise a paper carrying side layer 32, a intermediate layer 34 and a press side layer 36. The intermediate layer 34 formed in the batt layers 30 of the paper carrying side is made of a blend of staple fibers 50 and hollow fibers

52 or solely of hollow fibers 52. Hollow fibers 52 of intermediate layer 34, flattened under nip pressure, rebound to their uncompressed state as they are released from the nip pressure, exhibiting anti-rewetting effect by absorbing water within the press felt 10 into the void core from the ends before the water backs to the wet paper web.

Fig. 1

10

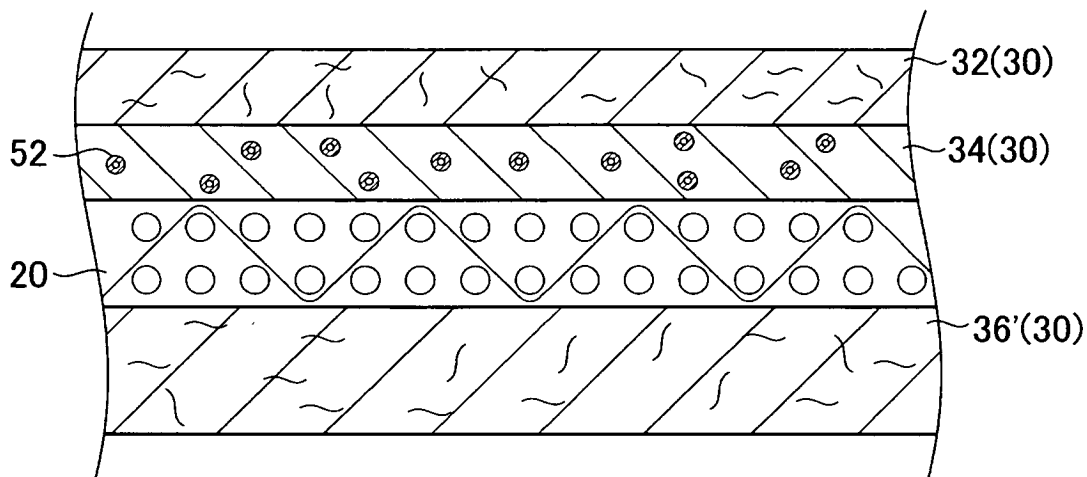

Description

FIELD OF THE INVENTION

5 **[0001]** The present invention relates to a felt used for a press section of a papermaking machine, and particularly to a press felt for papermaking which is capable of enhancing the dewatering ability (hereinafter referred to as a "press felt").

BACKGROUND ART

10 **[0002]** In a papermaking process, a press machine is conventionally used to dewater a wet paper web.

[0003] In the press machine, a wet paper web is dewatered through a press felt within a press nip. A press machine usually has a plurality of press nips.

[0004] Figure 5 is a schematic view of a press nip in a press machine.

15 **[0005]** The press nip as shown comprises a pair of press rolls P', P' and a pair of press felts 11', 11' holding a wet paper web W' in between. The press felts 11', 11' and the wet paper web W' are compressed within a nip between the press rolls P', P', and the press felts 11', 11' absorbs the water from the wet paper web W'.

[0006] The wet paper web W' and the press felts 11', 11' are rapidly released from the pressure as it exits the nip.

20 **[0007]** In the process, the volumes of the press felts 11', 11' and the wet paper web W' drastically expand to produce negative pressures within the press felts 11', 11'. Moreover, since the wet paper web W' is composed of thin fibers, a capillary phenomenon occurs.

[0008] As a result, rewetting occurs, a phenomenon that the water absorbed by the press felts 11', 11' backs to the wet paper web, a problem to be solved for those skilled in the art.

[0009] With the object to prevent rewetting, unexamined Japanese Patent Publication No. 143627/2004, for example, discloses a batt layer comprising an ultra fine fiber or a hydrophilic nonwoven fabric.

25 **[0010]** Figure 6 is a CMD sectional view of a conventional press felt 10'.

[0011] As shown in Figure 6, a conventional press felt 10' comprises a base fabric 20', batt layers 30' and a hydrophilic nonwoven fabric 40', all of which are needled together to form a press felt.

30 **[0012]** The batt layers 30' comprise a paper web side layer 31' and a press side layer 32'. The batt layers 30' are composed of the base fabric 20' to which staple fibers 50' are needled. Therefore, the staple fibers 50' are disposed in the base fabric 20'.

[0013] The hydrophilic nonwoven fabric 40' is positioned in the paper web side layer 31'.

[0014] A spunbonded nonwoven fabric is employed by way of an example as the hydrophilic nonwoven fabric 40', which is made of hydrophilic nylon fibers with the fineness of 4 or less deci tex (dtex).

35 **[0015]** The hydrophilic nonwoven fabric 40' has higher density and less permeability to water than the batt material. Because of such characteristics, the water within a second paper web side layer 31b' and the roll side layer 32' is hard to permeate the hydrophilic nonwoven fabric 40' into the wet paper web.

[0016] Moreover, since the hydrophilic nonwoven fabric 40' is less finer than the batt layers 30', the water within the first paper web side layer 31a' is absorbed easily into the hydrophilic nonwoven fabric 40' due to a capillarity phenomenon.

40 **[0017]** Thus, according to this invention, the conventional press felt 10' has a high anti-rewetting effect with a hydrophilic nonwoven fabric positioned within the paper web side layer of the batt layers.

[0018] Additionally, US Patent No. 6179965 discloses a press felt for which hollow monofilament yarns are used as warps or wefts to form a base fabric.

[0019] According to this invention, the base fabric formed with hollow fibers has higher resiliency, increasing the contact area within the nip, which translates into improved dewatering and prevention of rewetting.

45

DISCLOSURE OF THE INVENTION

50 **[0020]** However, in forming a conventional press felt, for example, the one disclosed in the Japanese Patent Publication, advanced technology is required to place the hydrophilic nonwoven fabrics uniformly in an appropriate position within the paper web side layer without creases or overlaps.

[0021] As for the press felt with the base fabric made of hollow filament yarns, the characteristics of such yarns are not fully utilized in terms of prevention of rewetting, in that the void core does not have the effect to absorb the water within the press felt, because the hollow filament yarns are lint filaments and hence their ends are not integrated into the press felt.

55 **[0022]** In the context of the above, the present invention concerns the backing of the water to a wet paper web with the release of the press felt from compression as it exits the press nip ("rewetting"), with an object to provide a press felt for papermaking which is capable of reducing the amount of water transferring to the paper web side layer and hence the rewetting phenomenon, by utilizing hollow fibers.

[0023] The present invention solved above-mentioned problems by providing a press felt for papermaking with batt layers comprising a paper web side layer and a press side layer, characterized in that within said paper web side layer an intermediate layer is formed which includes hollow staple fibers (hereinafter referred to as "hollow fibers") .

[0024] According to the present invention, when the hollow fibers rebound to their uncompressed state as the press felt is released from nip pressure, the water within the press felt can be absorbed into the void cores at the ends of the hollow fibers. As a result, the water is prevented from backing to the surface of the press felt, resulting in the effective prevention of rewetting. Since staple fibers are usually short fibers (cut cotton) which range from 50 to 150mm in length, a number of ends thereof are integrated in the batt layers of the press felt.

[0025] In short, the present invention can provide a press felt for papermaking with a superior anti-rewetting effect, by a relatively simple structure in which an intermediate layer including staple fibers is disposed in the batt layer of the paper web side.

BRIEF DESCRIPTION OF DRAWINGS

[0026]

Figure 1 is a sectional view of an embodiment of the press felt of the present invention.

Figure 2 is a sectional view of another embodiment of the press felt of the present invention.

Figure 3 is a schematic of an apparatus to verify the effects of the press felt of the present invention.

Figure 4 is a schematic of an apparatus to verify the effects of the press felt of the present invention.

Figure 5 is a schematic of a press machine for papermaking.

Figure 6 is a sectional view of a conventional press felt.

PREFERRED EMBODIMENT OF THE INVENTION

[0027] Referring to Figure 1 and 2, an embodiment of the press felt 10 of the present invention is to be described.

[0028] Figure 1 and Figure 2 are CMD sectional views of the press felt 10 of the present invention.

[0029] "Machine direction (MD)" means the longitudinal direction toward which a paper machine transfers a press felt, whereas "cross machine direction" (CMD) means the latitudinal direction crossing said direction toward which a paper machine transfers a press felt.

[0030] Referring to Figure 1, the press felt 10 comprises a base fabric 20 and batt layers 30, which are needled together to form a press felt for papermaking.

[0031] The base fabric 20 is provided to impart strength to the press felt 10, and can be made of various materials proposed by those skilled in the art, such as a woven fabric, an unwoven material with yarns laid on each other, or a film.

[0032] Preferable materials for the base fabric 20 are natural fibers such as wool, synthetic fibers such as polyester, nylon 6, and nylon 66 etc. with a selected resiliency, tenacity, anti-wearing and anti-stain characteristics.

[0033] Batt layers 30 comprise a paper web side layer 32, an intermediate layer 34, and a press side layer 36.

[0034] In a pick-up felt used for the first step of the press section, preferred staple fibers 50 for the batt layers 30 are those with the fineness of about 10-25 deci tex (dtex) for the paper web side layer 32, and those with the fineness of about 15-25 deci tex (dtex) for the press side layer 36.

[0035] As for felts used in the second and the third press machines in the middle step of the press section, preferred staple fibers 50 are those with the fineness of about 10-15 deci tex (dtex) for the paper web side layer 32, and those with the fineness of about 10-20 deci tex (dtex) for the press side layer 36.

[0036] For a felt used in the fourth press machine or a shoe press in the last step of the press section, preferred staple fibers 50 are those with the fineness of about 5-15 deci tex (dtex) for the paper web side layer 32, and those with the fineness of about 5-20 deci tex (dtex) for the press side layer 36.

[0037] The structure etc. of a press section in a press machine for paper making is not to be described in this specification, because it is well-known to those skilled in the art, and described in detail, for example, in Unexamined Japanese Patent Publication No. 143627/2004 (paragraph 0002 to 0005, 0037 and 0038, Figure 1 and Figure 14).

[0038] An intermediate layer 34 including hollow fibers 52 is positioned within the batt layers 30 of the paper web side.

[0039] The intermediate layer 34 can be made either of a blend of the staple fibers 50 and the hollow fibers 52 or solely of the hollow fibers 52.

[0040] When the intermediate layer 34 is made of the hollow fibers 52 only, the basis weight thereof should be in the range of 100-300g/m², around 200g/m² being most preferred. The intermediate layer 34 can be made of 25-75 % by weight of the hollow fibers 52 with the staple fibers 50 composing the rest.

[0041] The sectional shape of the hollow fibers 52 includes but not limited to a circle, a square, a star, or can be porous. A synthetic fiber such as polyester or nylon with the fineness of 3-25 deci tex (dtex) may be employed as the hollow fibers 52. The hollow fibers 52 range from 50 to 150mm in length. The hollow fibers 52, for example with a circle-

shaped hollow, is capable of rebounding to their uncompressed state as it is released from the compression after being subjected to nip pressures, and have a selected anti-wearing characteristic against repetitive compression.

[0042] Preferred hollow fibers 52 for the intermediate layer 34 are those with the fineness of about 15-25 deci tex (dtex) in the pick-up felt used for the first step of the press section, and with the fineness of about 10-20 deci tex (dtex) in the felt used in the second and the third press machines in the middle step of the press section, and with the fineness of about 5-20 deci tex (dtex) in the felt used in the fourth press machine or a shoe press in the last step of a press section.

[0043] Since the base fabric 20 and the batt layers 30 are needled together, the staple fibers 50 and hollow fibers 52 are interwoven into the base fabric 20, resulting in a firmly and stably integrated press felt.

[0044] Referring to Figure 1, the effects of the press felt 10 are to be explained.

[0045] In a conventional press felt, rewetting occurs, where the water absorbed by the press felt 10 backs to the wet paper web as the press felt travels out the nip. However, the press felt 10 of the present invention has the intermediate layer 34 comprising hollow fibers which are easily flattened by the nip pressure. Then the density of the intermediate layer 34 increases, but due to the nip pressure, the water transfers to the base fabric and the press side layer 36 which are formed between the intermediate layer 34 and the press roll. With especially effective compression, the water is pressed out of the press side layer 36 to the press roll side.

[0046] Moreover, when the press felt 10 travels out of the nip, and as the hollow fibers 52 are released from the compression, they rebound to their uncompressed state. In this process, the water left within the press felt 10 and especially within the base fabric 20 and the press side layer 36 is absorbed through the ends of the hollow fibers 52 in the intermediate layer 34, before the water backs to the wet paper web.

[0047] As a result, the press felt 10 of the present invention effectively prevents rewetting, by reducing the water backing to the paper web side 32 as the felt is released from the nip pressure.

[0048] Furthermore, with the more hollow fibers 52 included in the intermediate layer 34, the hollow fibers 52 absorb more water from the batt layers 30 and therefore reduce the water transferring from the paper web side layer 32 back to the wet paper web.

[0049] As shown in Figure 2, the batt layers 30 of the paper web side comprises a plurality of layers: a first paper web side layer 32a which contacts the wet paper web and a second paper web side layer 32b which contacts the base fabric.

[0050] In the first paper web side layer 32a, intermediate layers 34a, 34b and 34c are formed between the paper contacting layer 320a and the base fabric 20. The intermediate layer 34 is formed as a part of the second paper web side layer 32b.

[0051] The ratio of the hollow fibers blended in the intermediate layers 34a, 34b, 34c, and 34 increases in the order hereof, namely, the more distant from the paper contacting side layer 320a, the more hollow fibers 52 are blended therein. Due to such a composition, smoothness of the paper contacting side layer 320a against the wet paper web is maintained, whereas more water within the batt layers 30 is absorbed by the hollow fibers 52, thereby reducing the water transferring from the paper contacting side layer 320a back to the wet paper web.

[0052] An experiment was conducted to compare the effects of the present invention with those of a conventional press felt, using a press felt having batt layers 30 of a simple construction. The hollow fibers 52 for the intermediate layer 34 was set at seven deci tex (dtex) in fineness and the basis weight of the intermediate layer 34 was set at 200g/m².

[0053] The basis weight of the paper contacting layer 320a, the intermediate layer 34a, 34b and 34c was set at 50g/m². The paper contacting layer 320a was made of staple fibers 50 only, while the staple fibers 50 and the hollow fibers 52 were blended in the ratio of 75%:25% by the basis weight for the intermediate layer 34a, 50%:50% for the intermediate layer 34b, 25%:75% for the intermediate layer 34c..

(EMBODIMENTS)

[0054] The following experiment was conducted to determine the effects of the press felt of the present invention.

[0055] In order to equalize conditions for the embodiments and a comparative example, the basic construction of all the felts were set as follows: base body (plain-woven fabric with twisted yarns of nylon monofilament) - basis weight 300g/m²; batt layer (nylon 6 and hollow staple fibers) - total basis weight 550g/m², needle punching frequency 700 times/cm².

[0056] The embodiments had an intermediate layer comprising hollow fibers within the paper web side layer of batt layers which comprises a paper web side layer (a first paper web side layer and a second paper web side layer) and a press side layer.

[0057] Table 1 shows the above-mentioned materials, the fineness and the basis weight of the embodiments and the comparative example.

[0058] Experiments were conducted with the press machines shown in Figure 3 and 4, using press felts for papermaking of said embodiments and the comparative example.

[0059] Referring to Figure 3 and 4, P is press rollers, 110 is an upper side felt, 10 is a downside felt, SC is a suction tube, and SN is a shower nozzle.

EP 1 944 411 A1

[0060] Said embodiments and comparative example are used as the downside felt 10 in both machines. And a press felt shown as the comparative example 1 in the Table 1 is used as the upper side felt 110.

[0061] In press machines shown in Figure 3 and 4, the felt travels 500m/min and is subjected to nip pressures of 100kg/cm.

5 **[0062]** In the press machine of Figure 3, the wet paper web released from the nip pressure is placed on and transferred by the downside felt 10. Accordingly, water content data of a rewet paper web can be gathered by measuring the humidity of the wet paper web at a position (press exit 1) where a wet paper web is transferred by the downside felt 10 after it exits the nip.

10 **[0063]** On the other hand, in the press machine of Figure 4, the downside felt 10 is in contact with the press roller over a larger area, resulting in a brief contact of a wet paper web released from the nip pressure with the felts 10, 110. Water content data of the wet paper web with less rewetting can be gathered, by measuring the humidity of the wet paper web at the position (press exit 2) where it just travels out of the nip.

15 **[0064]** The next step is to evaluate whether rewetting occurred based on the difference between the respective water content data gathered with the press machines shown in Figure 3 and 4. When the difference is less than 0.5%, it is considered no rewetting occurred (evaluated as "good"), whereas the difference ranging from 0.5% to less than 1.0% is considered to be with slight rewetting (evaluated as "fair"), and when the difference exceeds 1.0% it is considered that rewetting occurred (evaluated as "failure").

[0065] The results of the experiments are shown in Table 1.

Table 1

	First Paper Web Side Layer	Second Paper Web Side Layer	Press Side Layer	Water Content at Exit 2 (%)	Water Content at Exit1 (%)	Rewetting Evaluation
25 Embodiment 1	7 dtex Nylon 6 with Basis Weight of 200g/m ²	7 dtex Hollow Fiber with Basis Weight of 200g/m ²	17 dtex Nylon 6 with Basis Weight of 150g/m ²	48	48.3	Good

30

35

40

45

50

55

EP 1 944 411 A1

(continued)

5

10

15

20

25

30

35

40

45

50

55

	First Paper Web Side Layer	Second Paper Web Side Layer	Press Side Layer	Water Content at Exit 2 (%)	Water Content at Exit1 (%)	Rewetting Evaluation
Embodiment 2	Composed of 4 layers in the order hereof from Paper Web Side toward Press Side First Layer: 7dtex Nylon 6 with Basis Weight of 50g/m ² Second Layer: Blend of 75% 7dtex Nylon 6 and 25% Hollow PET Fiber with Basis Weight of 50g/m ² Third Layer: Blend of 50% 7dtex Nylon 6 and 50% Hollow PET Fiber with Basis Weight of 50g/m ² Fourth Layer: Blend of 25% 7dtex Nylon 6 and 75% Hollow PET Fiber with Basis Weight of 50g/m ²	ditto	ditto	47.5	47.6	Good
Embodiment 3	ditto	7 dtex Nylon 6 with Basis Weight of 200g/m ²	ditto	47.6	47.7	Good

(continued)

	First Paper Web Side Layer	Second Paper Web Side Layer	Press Side Layer	Water Content at Exit 2 (%)	Water Content at Exit1 (%)	Rewetting Evaluation
Comparative Example 1	7 dtex Nylon 6 with Basis Weight of 200g/m ²	7 dtex Nylon 6 with Basis Weight of 200g/m ²	ditto	48	50	Failure
Rewetting Evaluation ⇒ Water Content at Exit 1 - Water Content at Exit 2 Less than 0.5=Good 0.5~less than 1.0=Fair 1.0 or more=Failure						

[0066] As shown in Table 1, the press felt for papermaking of the present invention has a beneficial effect on the prevention of rewetting.

[0067] Especially, the comparison between the embodiments and the comparative example proved the effect of forming an intermediate layer including hollow fibers within the paper web side layer of the batt layers.

[0068] Moreover, the experiments with the embodiments 2 and 3 showed that the preferred embodiment of the present invention is said batt layers being multilayered with the first layer on the paper web side being made of nylon without hollow fibers and the other layers comprising 25 to 75% of nylon and 75 to 25% of hollow fibers.

INDUSTRIAL APPLICABILITY

[0069] As described above, the present invention provides a press felt for papermaking with an excellent anti-rewetting effect, by employing a relatively simple structure in which an intermediate layer including hollow fibers is disposed in the batt layer of the paper web side.

Claims

1. A press felt for papermaking with batt layers having a paper web side layer and a press side layer, **characterized in that** an intermediate layer including hollow staple fibers is disposed in said batt layers of the paper web side.
2. A press felt for papermaking as claimed in claim 1, wherein said paper web side batt layer is multilayered with the first layer on the paper web side being made of nylon without said hollow staple fibers and the other layers being made of a blend of nylon and hollow fibers in the ratio of 25 to 75%:75 to 25%.

Fig. 1

10

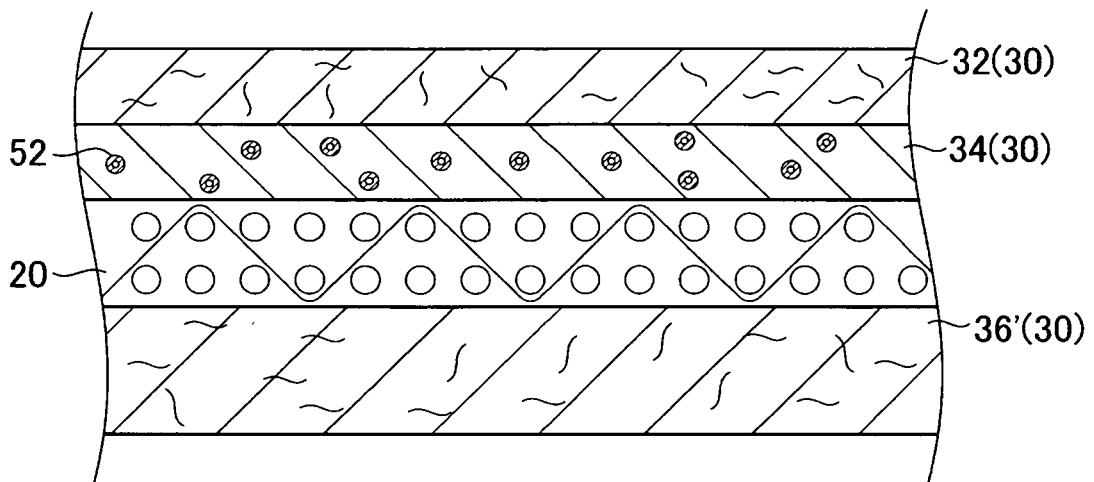

Fig. 2

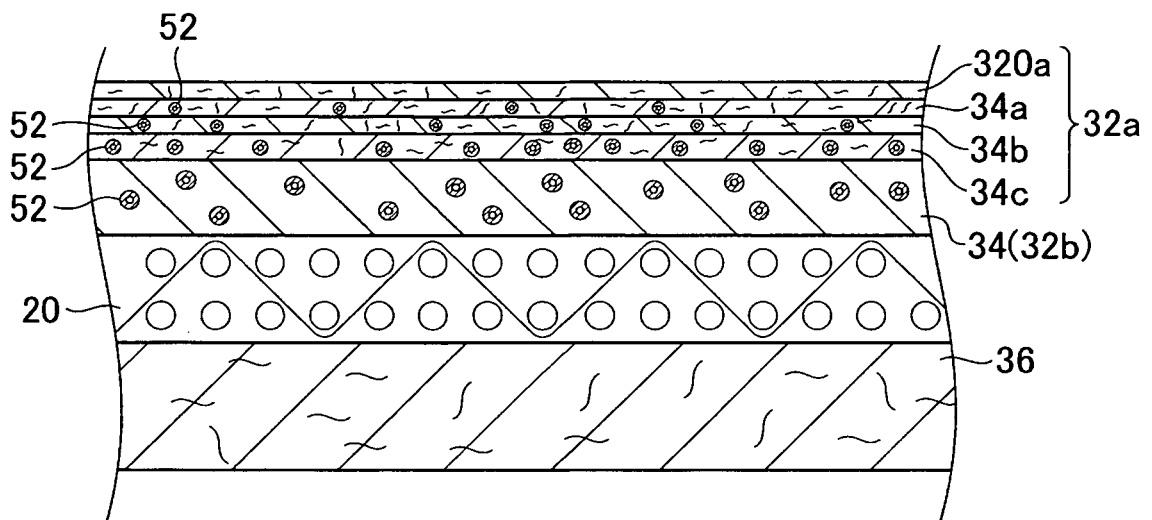

Fig. 3

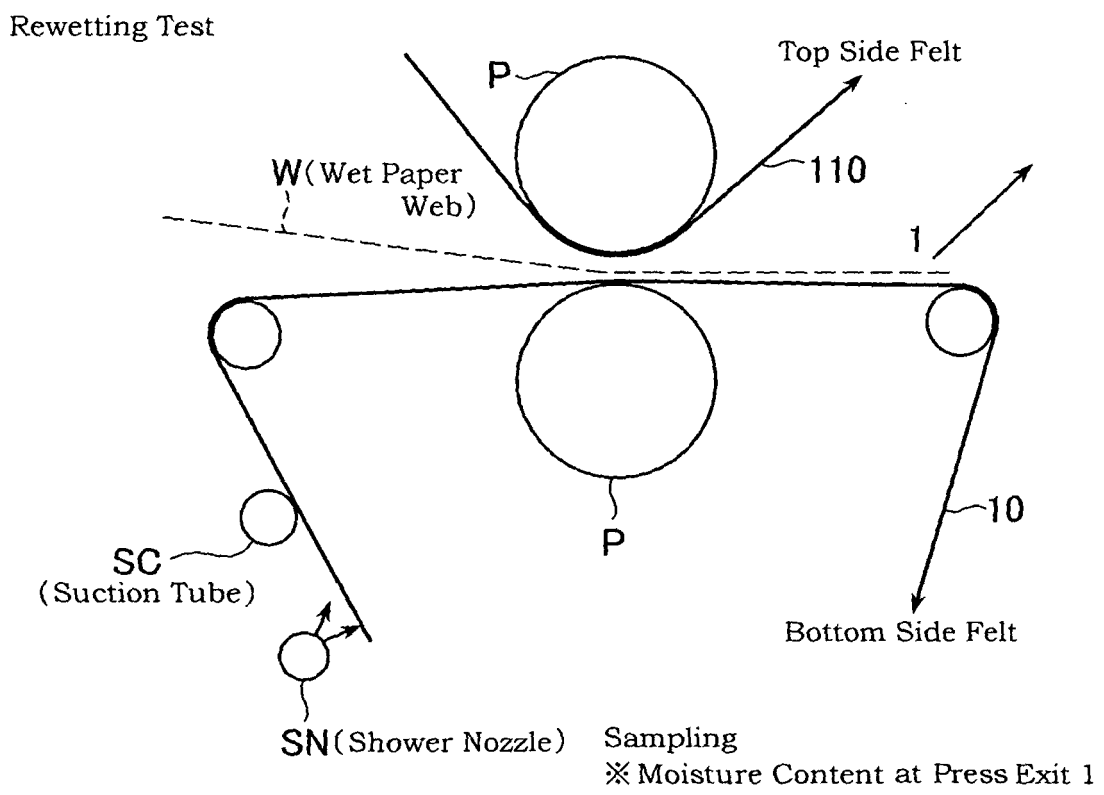

Fig. 4

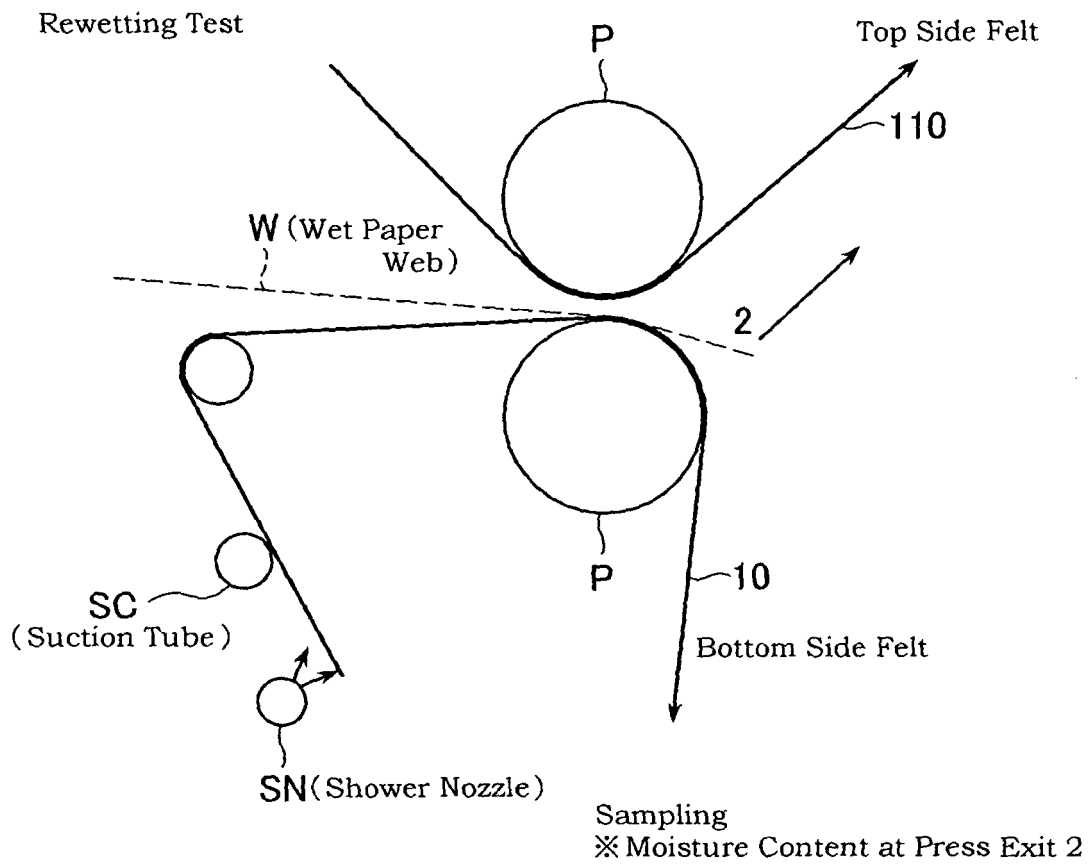

Fig. 5

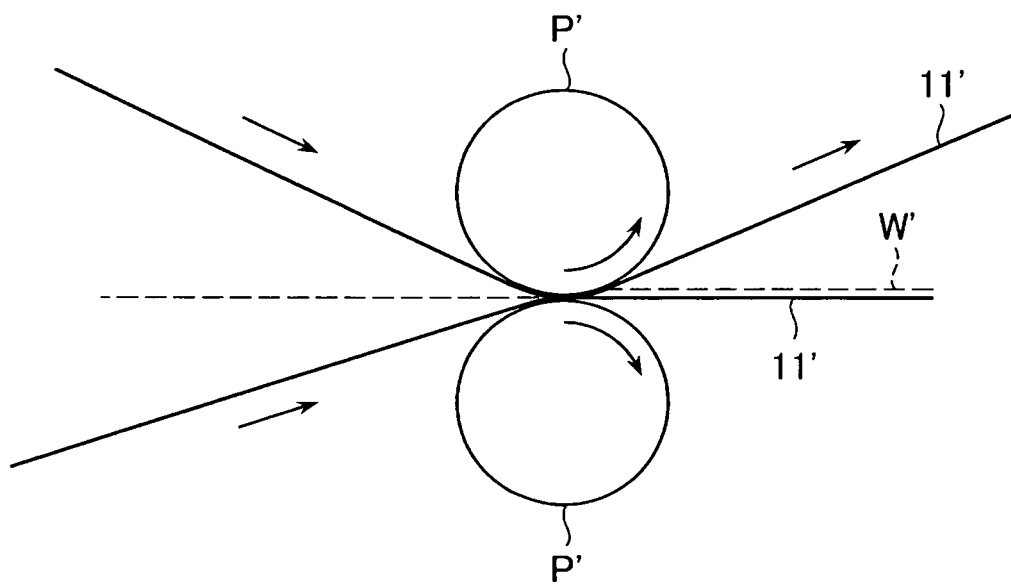
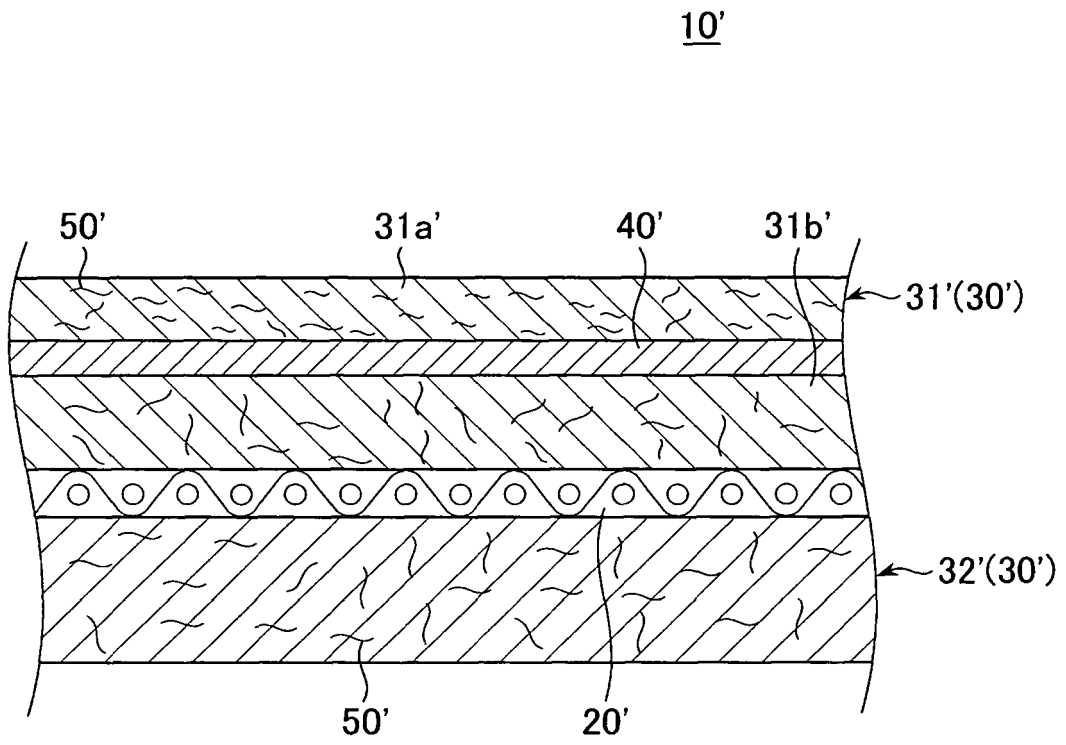

Fig. 6



INTERNATIONAL SEARCH REPORT

International application No.

PCT/JP2006/316060

A. CLASSIFICATION OF SUBJECT MATTER D21F7/08(2006.01) i		
According to International Patent Classification (IPC) or to both national classification and IPC		
B. FIELDS SEARCHED		
Minimum documentation searched (classification system followed by classification symbols) D21F7/08		
Documentation searched other than minimum documentation to the extent that such documents are included in the fields searched Jitsuyo Shinan Koho 1922-1996 Jitsuyo Shinan Toroku Koho 1996-2006 Kokai Jitsuyo Shinan Koho 1971-2006 Toroku Jitsuyo Shinan Koho 1994-2006		
Electronic data base consulted during the international search (name of data base and, where practicable, search terms used)		
C. DOCUMENTS CONSIDERED TO BE RELEVANT		
Category*	Citation of document, with indication, where appropriate, of the relevant passages	Relevant to claim No.
Y	US 4569883 A (Albany International Corp.), 11 February, 1986 (11.02.86), Column 5, lines 48 to 68 & JP 62-162094 A & JP 3-174085 A & EP 191231 A & NO 854714 A & AU 5219586 A & FI 854686 A & BR 8506387 A & CA 1268395 A & ZA 8509175 A & MX 165890 B	1-2
Y	US 4851281 A (Huyck Corp.), 25 July, 1989 (25.07.89), Claims 2, 14, 16; column 2, lines 11 to 27 & JP 2-503015 A & EP 362226 A & WO 88/07929 A1 & AU 1701188 A & FI 894620 A & CA 1302763 A	1-2
<input checked="" type="checkbox"/> Further documents are listed in the continuation of Box C. <input type="checkbox"/> See patent family annex.		
* Special categories of cited documents:		
"A"	document defining the general state of the art which is not considered to be of particular relevance	"T" later document published after the international filing date or priority date and not in conflict with the application but cited to understand the principle or theory underlying the invention
"E"	earlier application or patent but published on or after the international filing date	"X" document of particular relevance; the claimed invention cannot be considered novel or cannot be considered to involve an inventive step when the document is taken alone
"L"	document which may throw doubts on priority claim(s) or which is cited to establish the publication date of another citation or other special reason (as specified)	"Y" document of particular relevance; the claimed invention cannot be considered to involve an inventive step when the document is combined with one or more other such documents, such combination being obvious to a person skilled in the art
"O"	document referring to an oral disclosure, use, exhibition or other means	"&" document member of the same patent family
"P"	document published prior to the international filing date but later than the priority date claimed	
Date of the actual completion of the international search 01 September, 2006 (01.09.06)	Date of mailing of the international search report 12 September, 2006 (12.09.06)	
Name and mailing address of the ISA/ Japanese Patent Office	Authorized officer	
Facsimile No.	Telephone No.	

EP 1 944 411 A1

INTERNATIONAL SEARCH REPORT

International application No. PCT/JP2006/316060
--

C (Continuation). DOCUMENTS CONSIDERED TO BE RELEVANT		
Category*	Citation of document, with indication, where appropriate, of the relevant passages	Relevant to claim No.
A	US 5368696 A (Asten Group, Inc.), 29 November, 1994 (29.11.94), Claims; column 2, lines 12 to 15; column 5, lines 44 to 47 & US 6179965 B & EP 590927 A1 & FI 934279 A & CA 2107457 A	1-2
A	JP 2004-143627 A (Ichikawa Keori Kabushiki Kaisha), 20 May, 2004 (20.05.04), All references & US 2004-137819 A1 & EP 1413673 A1 & NO 20034216 A & CA 2446249 A & BR 304646 A & NZ 529100 A	1-2
A	US 4856562 A (Asten Group, Inc.), 15 August, 1989 (15.08.89), All references & US 4883097 A & EP 59973 A1 & NO 820738 A & FI 820791 A & ZA 8201632 A & GR 75898 A	1-2

Form PCT/ISA/210 (continuation of second sheet) (April 2005)

REFERENCES CITED IN THE DESCRIPTION

This list of references cited by the applicant is for the reader's convenience only. It does not form part of the European patent document. Even though great care has been taken in compiling the references, errors or omissions cannot be excluded and the EPO disclaims all liability in this regard.

Patent documents cited in the description

- JP 2004143627 A [0009] [0037]
- US 6179965 B [0018]