

Jan. 16, 1962

E. J. GATES

3,017,233

COUNTERS AND SLIDING CLOSURES THEREFOR

Filed May 21, 1959

5 Sheets-Sheet 1

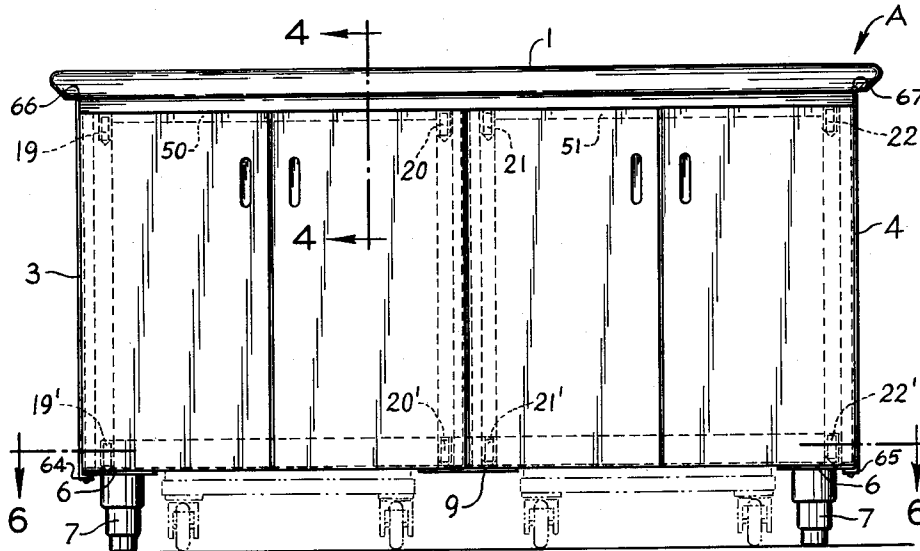

FIG. 1.

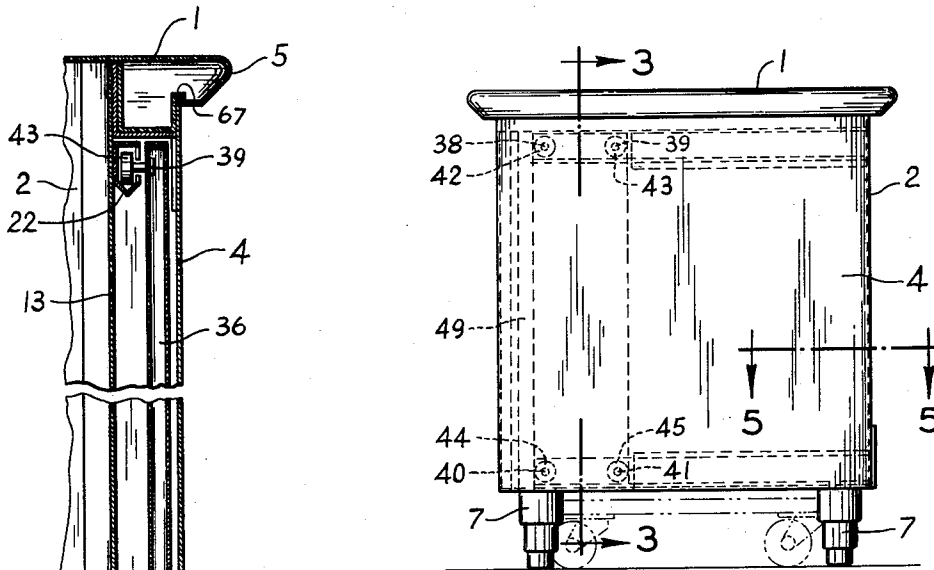

FIG. 2.

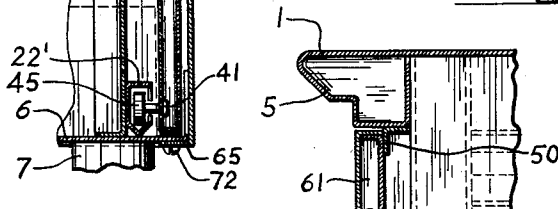

FIG. 3.

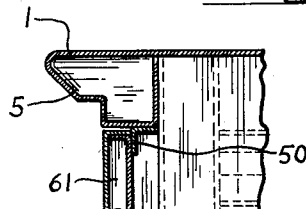

FIG. 4.

INVENTOR.
EARL J. GATES

BY *Alfred W. Petchcraft*
ATTORNEY

Jan. 16, 1962

E. J. GATES

3,017,233

COUNTERS AND SLIDING CLOSURES THEREFOR

Filed May 21, 1959

5 Sheets-Sheet 2

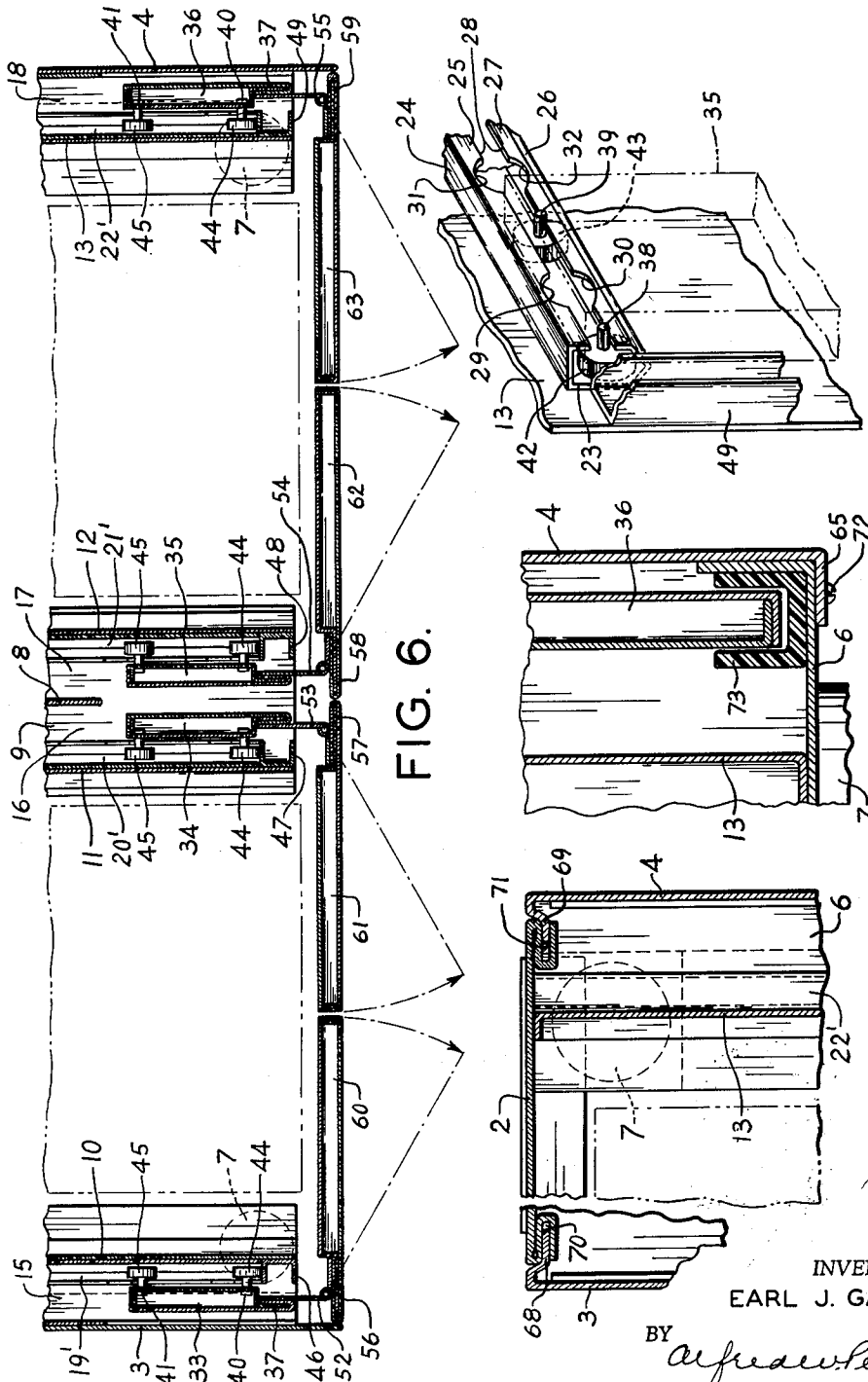

FIG. 6.

FIG. 7.

FIG. 9.

FIG. 5.

INVENTOR.
EARL J. GATES

BY *Alfred W. Petchaft*
ATTORNEY

Jan. 16, 1962

E. J. GATES

3,017,233

COUNTERS AND SLIDING CLOSURES THEREFOR

Filed May 21, 1959

5 Sheets-Sheet 4

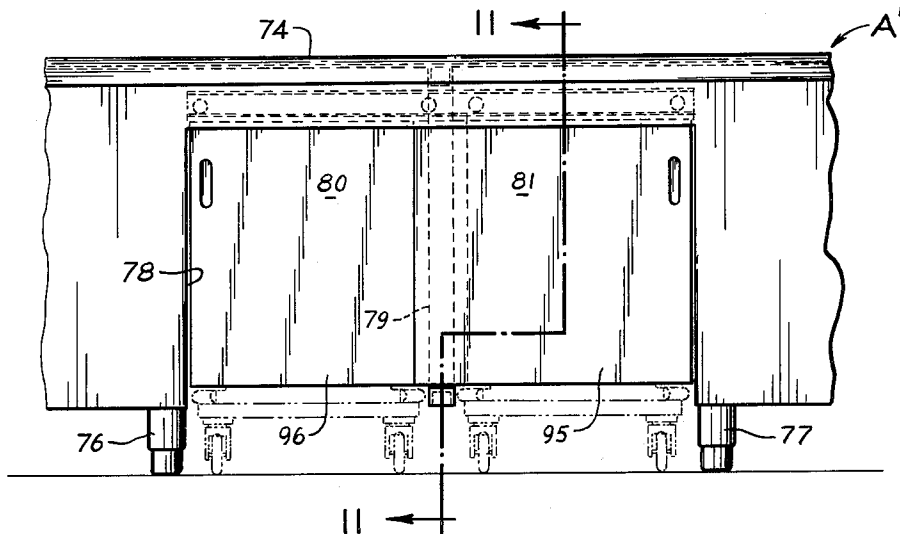

FIG. 10.

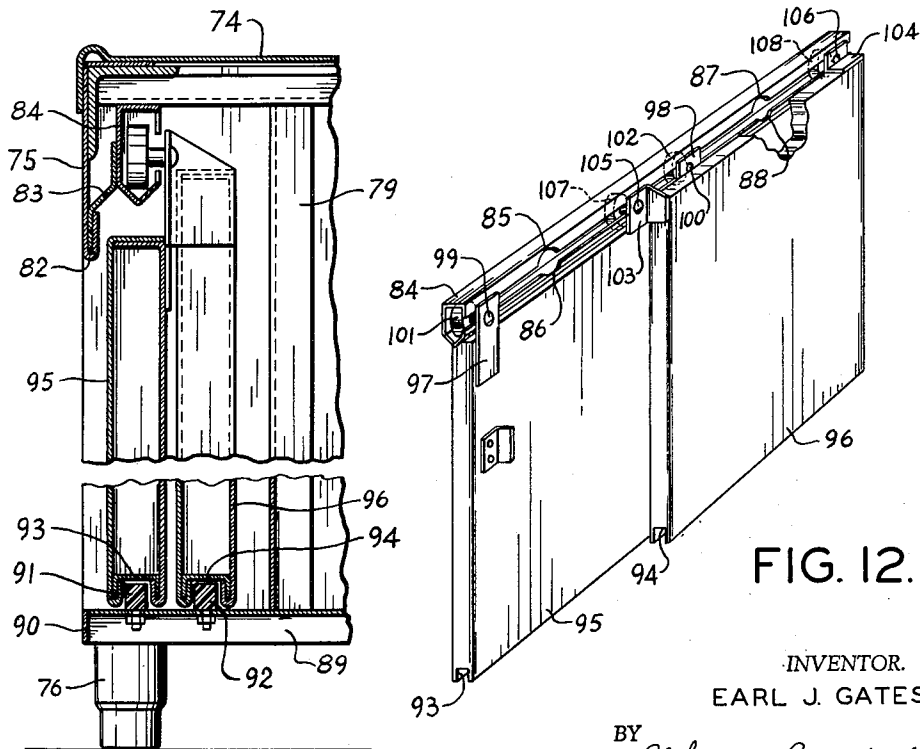

FIG. 11.

FIG. 12.

INVENTOR.
EARL J. GATES

BY *Alfred Petchaft*
ATTORNEY

Jan. 16, 1962

E. J. GATES

3,017,233

COUNTERS AND SLIDING CLOSURES THEREFOR

Filed May 21, 1959

5 Sheets-Sheet 5

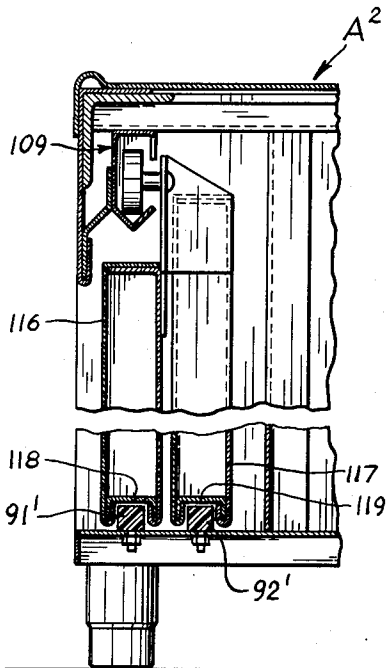

FIG. 14.

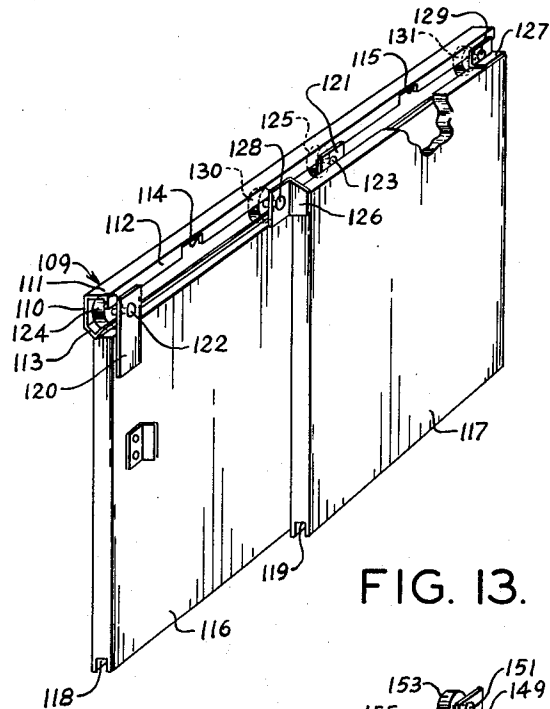

FIG. 13.

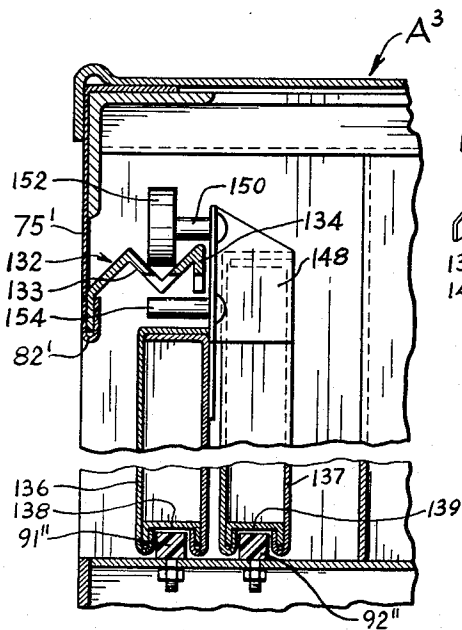

FIG. 15.

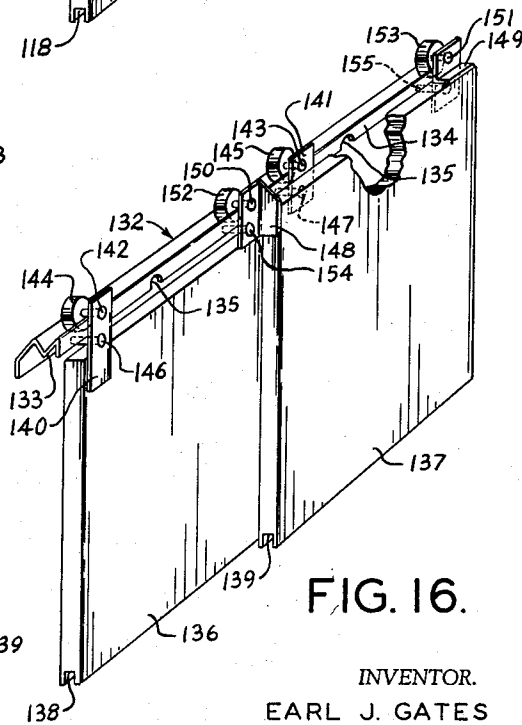

FIG. 16.

INVENTOR.
EARL J. GATES

BY

Arthur H. Kraft

ATTORNEY

1

3,017,233

**COUNTERS AND SLIDING CLOSURES
THEREFOR**

Earl J. Gates, Affton, Mo., assignor to Servco Equipment Company, St. Louis, Mo., a corporation of Missouri

Filed May 21, 1959, Ser. No. 814,831
8 Claims. (Cl. 312—322)

This invention relates in general to certain new and useful improvements in food service equipment, and, more particularly, to counters for use in restaurants, cafeterias, and the like.

In many types of food service operations it is necessary to utilize counters or tables having storage space beneath the top, and this storage space may be used for a wide variety of purposes. For instance, in cafeteria counters it is common practice to place extra racks of clean dishes in these storage compartments so that a supply of clean tableware is available when needed. Similarly, it is common practice to place a receptacle for dirty dishes and tableware, and, from time to time, the bus boys or other restaurant employees will remove the receptacles to the kitchen for dish scraping and dishwashing operations. Usually, such storage compartments are of the open-faced open-shelf type and the dishes or other articles stored thereon are visible and unprotected from the rear. In the case of clean dishes or spare kettles of food, this creates a sanitary problem and frequently the unprotected rear faces of such counters are visible to the patrons, at least to some extent. Moreover, the open-shelf arrangement presents cleaning problems, and it is often difficult to lift heavy containers, racks, kettles, and the like, into and out of such compartments.

It is, therefore, the primary object of the present invention to provide a counter or table-like structure for use in restaurants, cafeterias, and the like, which structure has a storage compartment arranged for convenient access, but which, nevertheless, can be readily closed so as to present an attractive appearance and afford some measure of sanitary protection to the contents of the compartment.

It is another object of the present invention to provide a counter or table-like structure of the type stated which has an unobstructed compartment so that racks, dish containers, and other articles of a similar nature can be freely rolled into and out of the compartment on wheeled trucks, or the like.

It is a further object of the present invention to provide a compartmented counter or table of the type stated having an efficient closure or door-structure which can be readily swung open and shifted into a completely concealed storage position so as to provide free and unimpeded access to the storage compartment.

It is another object of the present invention to provide counters and tables of the type stated having storage compartments provided with doors which can be easily and conveniently removed for repair or replacement.

With the above and other objects in view, my invention resides in the novel features of form, construction, arrangement, and combination of parts presently described and pointed out in the claims.

In the drawings—

FIG. 1 is a front elevational view of a counter constructed in accordance with and embodying the present invention;

FIG. 2 is a side elevational view of the counter;

FIG. 3 is a fragmentary sectional view taken along line 3—3 of FIG. 2;

FIG. 4 is a fragmentary sectional view of the counter taken along line 4—4 of FIG. 1;

FIG. 5 is a fragmentary sectional view taken along line 5—5 of FIG. 2;

2

FIG. 6 is a fragmentary sectional view taken along line 6—6 of FIG. 1;

FIG. 7 is a fragmentary perspective view of a portion of the roller track mechanism forming a part of the present invention;

FIG. 8 is a fragmentary horizontal sectional view showing the closure structure in fully open position;

FIG. 9 is a fragmentary sectional view of a modified form of guide roller construction forming a part of the present invention;

FIG. 10 is a fragmentary front elevational view of a modified form of the counter constructed in accordance with and embodying the present invention;

FIG. 11 is a fragmentary sectional view taken along line 11—11 of FIG. 10;

FIG. 12 is a perspective view of the doors and roller track structure forming a part of the modified form of the invention shown in FIG. 10;

FIG. 13 is a perspective view of a modified form of the door and roller track construction forming a part of the present invention;

FIG. 14 is a fragmentary vertical sectional view of a counter embodying the modified form of the door and roller track construction shown in FIG. 13;

FIG. 15 is a fragmentary vertical sectional view of a further modified form of the door and roller track construction forming a part of the present invention;

FIG. 16 is a perspective view of a door and roller track construction of the counter embodiment shown in FIG. 15;

FIG. 17 is a fragmentary sectional view of a modified form of counter structure forming a part of and embodying the present invention showing such structure from the interior face; and

FIG. 18 is a fragmentary vertical sectional view taken along line 18—18 of FIG. 17.

Referring now in more detail and by reference characters to the drawings, which illustrate practical embodiments of the present invention, A designates an oblong rectangular counter constructed preferably of stainless steel panels, and including a top 1, a face-wall 2, and side walls 3, 4, the top 1 being marginally formed into a relatively heavy tubular channel 5 extending around the entire periphery thereof to provide strength and finish for the entire structure. The bottom margins of the face-wall 2 and side walls 3, 4, are connected by a U-shaped marginal bottom-rail 6 which is formed of relatively heavy strong material and lends structural strength to the lower portion of the counter A. Mounted upon the underface of the rail 6, approximately at the four corners of the counter A, are short depending legs 7. Rigidly secured to the top 1 and the face-wall 2 is an intermediate vertical partition 8 which is secured along its bottom marginal to a horizontal stringer-plate 9, thereby dividing the counter A into two storage compartments which open both rearwardly and downwardly. It should be noted in this connection that there is no bottom or other wall-forming member between the storage compartments and the floor, so that wheeled trucks or other similar devices may be freely rolled across the floor and into such compartments as shown in dotted lines in FIGS. 1 and 2.

Welded or otherwise rigidly secured at their upper and lower horizontal margins within the interior of the counter A are inner curtain-walls 10, 11, 12, and 13, respectively disposed in inwardly spaced parallel juxtaposed position to the side wall 3, the intermediate wall 8, and the side wall 4, thereby forming concealed door-receiving pockets 15, 16, 17, and 18, respectively. Spot-welded or otherwise rigidly mounted upon the upper and lower portions of the curtain-walls 10, 11, 12, 13, so as to be wholly within the door-receiving pockets 15, 16, 17, 18, are upper roller-tracks 19, 20, 21, 22, and lower roller-tracks 19', 20', 21', 22', respectively. Each of these roller-tracks 19,

20, 21, 22, and 19', 20', 21', 22' are of identical cross-sectional shape and integrally includes a back-web 23, a flat top-flange 24, provided with a depending marginal lip 25 which is parallel to the back-web 23, and a V-shaped bottom or track-forming channel 26 provided with an up-standing marginal lip 27 which is in co-planar alignment with the lip 25. As will be noted by reference to FIG. 7, the lips 25, 27 are spaced from each other along their longitudinal margins in the formation of a track-slot 28, and, furthermore, the lips 25, 27 are provided adjacent to the rear ends (the left side of FIG. 2 being, for convenience of reference, referred to as the rear side) of each of the roller-tracks 19, 20, 21, 22, 19', 20', 21', 22', with which they are respectively associated, with pairs of vertically aligned arcuate cut-outs 29, 30, and 31, 32 on the upper track, and 29', 30', and 31', 32' on the lower track, for purposes presently more fully appearing.

Provided for removable and sliding disposition within each of the door-receiving pockets 15, 16, 17, 18 are door-carriages 33, 34, 35, 36, which are preferably formed of sheet metal and are of hollow rectilinear construction. These door-carriages 33, 34, 35, 36 are of substantially similar shape and include a relatively thin forwardly projecting flange 37. Adjacent their upper and lower margins, the door-carriages 33, 34, 35, 36 are provided with laterally projecting pins 38, 39, 40, 41, having rollers 42, 43, 44, 45. The rollers 42, 43, 44, 45 on each door-carriage are so positioned or located as to slip through the pairs of cut-outs 29, 30, 31, 32, and 29', 30', 31', 32', and drop into the V-shaped track-forming channels 26.

Welded or otherwise rigidly secured to the curtain-walls 10, 11, 12, 13, and extending vertically between the forward ends of the roller-tracks 19, 19', 20, 20', 21, 21', and 22, 22', are reinforcing channels 46, 47, 48, and 49 which not only strengthen the curtain-walls 10, 11, 12, 13, but also serve as forward stops for the rollers 42, 44 of each of the door-carriages 33, 34, 35, 36. Also welded to the top of the counter and extending along the top margins of the compartment openings are depending flanges 50, 51, which act as door-stops.

Rigidly secured to the flanges 37 of each of the door-carriages 33, 34, 35, 36 are long piano-type hinges 52, 53, 54, 55, respectively, which are also in turn operably secured to vertical flanges 56, 57, 58, 59, each forming a part of doors 60, 61, 62, 63, the latter being paired and of such size that a pair will extend across, and form a closure for, the compartment openings, substantially as shown in FIGS. 1 and 6. As will be noted by reference to FIG. 6 the flanges 56, 57, 58, 59 project marginally beyond the pintles of the respective hinges 52, 53, 54, 55, and this projection is of such dimension that, when the doors are in closure-forming position, the forwardly presented opening or mouth of the door-receiving pockets 15, 16, 17, 18 will be fully covered and concealed to afford an attractive finished appearance. When the doors 60, 61, 62, 63 are swung open, in the direction indicated by the arrows in FIG. 6, the projecting portions of the flanges 56, 57, 58, 59 will fit edgewise against the margins of the flanges 37 of the respective door-carriages 33, 34, 35, 36, and the doors 60, 61, 62, 63 will stop in outwardly aligned position with respect to the door-receiving pockets 15, 16, 17, 18. From this latter position the doors 60, 61, 62, 63, together with their respective door-carriages 33, 34, 35, 36, can be shifted into completely housed and concealed position within the door-receiving pockets 15, 16, 17, 18. It will, of course, be understood that any one of the doors 60, 61, 62, 63, or any pair of them can be opened or closed in this manner. When the doors 60, 61, 62, 63 are in fully open position, of course, the door carriages are shifted fully to the rear of the door-receiving compartments 15, 16, 17, 18.

In order to improve the external appearance of the counter and simplify its construction, the side walls or panels 3, 4 are formed with inwardly bent or L-shaped bottom-flanges 64, 65, respectively, and the tubular chan-

nel 5 is formed with downwardly opening grooves 66, 67, as best seen in FIGS. 1 and 3. The forward vertical margins of the side walls 3, 4 are curled back to provide inwardly offset flanges 68, 69, which fit into U-shaped channels 70, 71, formed integrally in the vertical side margins of the face-wall 2 as shown in FIG. 5. In assembly, the flanges 68, 69 can be slipped into the channels 70, 71, and then pushed upwardly so that their upper horizontal margins are seated snugly in the grooves 66, 67. In this position the bottom-flanges 64, 65 will be brought up to flush abutment against the under-structure of the counter and may be secured by sheet-metal screws 72, or other suitable means, as best seen in FIG. 3.

If desired, an upwardly opening U-shaped nylon slide-channel 73 may be substituted for the lower roller-tracks 19', 20', 21', 22', as shown in FIG. 9.

It is also possible to provide a modified form of counter installation such as the counter A¹ shown in FIG. 10 which consists in part of a top 74, back-apron 75, and supporting legs 76, 77. Actually, the structural elements of the counter may be of any conventional design and, hence, are not described in detail herein. It is sufficient for present purposes, merely to point out that the back-apron 75 of the counter A¹ is cut away to form a rectangular opening 78 which extends across an unbottomed storage chamber, which is centrally subdivided by a relatively thick structurally strong partition 79 into two similar compartments 80, 81.

Across the upper horizontal margin of the opening 78, the back-apron 75 is bent back upon itself in the formation of a channel 82 which is crimped down upon the lower portion of a rearwardly offset mounting strip 83 to which is welded a single length of roller-track 84, the latter being substantially identical in form with the previously described roller-track 19, and being provided with two suitably spaced pairs of arcuate cut-outs 85, 86, and 87, 88.

The partition 79 is provided, along its bottom margin, with a projecting horizontal channel 89 having a depending flange 90 which lies substantially in the plane of the back-apron 75. Mounted in suitably spaced relation, as shown in FIG. 11, upon the upper face of the channel 89 are two cylindrical nylon plugs 91, 92, which fit bearing-wise in downwardly opening grooves 93, 94, respectively, of rectangular door-panels 95, 96. Welded or otherwise suitably attached to the rear face of the door panel 95 are small upwardly projecting flat plates 97, 98, having horizontal pins 99, 100, equipped with rollers 101, 102, which are located so as to fit through the pairs of cut-outs 85, 86, and 87, 88, so as to roll in the roller-track 84. Similarly mounted upon the other door panel 96 are offset-brackets 103, 104, the flanges of which are provided with horizontal pins 105, 106, having rollers 107, 108, respectively. The rollers 107, 108 are likewise located so as to fit through the pairs of cut-outs 85, 86, and 87, 88, and roll along the roller-track 84 in overlapping relation to the rollers 101, 102, so that the door panels 95, 96, will overlap as shown in FIG. 12.

It is also possible to provide a further modified form of counter installation, such as the counter A² shown in FIG. 14 which is substantially identical with the previously described form of counter A¹, and differs therefrom only in that it is provided with a roller-track 109 which integrally includes a back web 110, a flat top flange 111 provided with a depending marginal lip 112 which is parallel to the back web 110, and a V-shaped bottom or track-forming channel 113. The depending marginal lip 112 is provided at suitably spaced locations with two somewhat U-shaped rectilinear notches 114, 115. Provided for closurewise association with the counter A² are two overlapping rectangular door panels 116, 117, which are respectively provided in their lower margins with downwardly opening longitudinal grooves 118, 119, respectively, for sliding engagement with upwardly projecting cylindrical nylon plugs 91', 92', the

5

latter being substantially identical with, and being structurally embodied in the counter A² in substantially the same manner as the previously described nylon plugs 91, 92. The door panel 116 is provided on its rear face with upwardly projecting flat plates 120, 121, having horizontal pins 122, 123, equipped with rollers 124, 125, which are located so as to fit through the rectilinear notches 114, 115, so as to roll in the track-forming channel 113. Similarly mounted upon the other door panel 117 are offset brackets 126, 127, the flanges of which are provided with horizontal pins 128, 129, having rollers 130, 131, respectively. The rollers 130, 131 are likewise located so as to fit through the rectilinear notches 114, 115, and roll along the track-forming channel 113 in overlapping relation to the rollers 124, 125, so that the door panels 116, 117 will overlap as shown in FIG. 13.

It is also possible to provide a further modified form of counter installation such as the counter A³ shown in FIG. 15. The counter A³ is substantially similar in general construction and configuration to the previously described counters A¹ and A², having a back-apron 75' which is bent back upon itself in the formation of a channel 82', both the back-apron 75' and the channel 82' being substantially similar to the previously described back apron 75 and channel 82. The channel 82' is crimped down upon the lower portion of a rearwardly offset roller-track 132 integrally provided along its upwardly and rearwardly presented longitudinal margins with a V-shaped track-forming channel 133 which is, in turn, integrally provided on its upwardly and rearwardly presented longitudinal margins with a depending vertical lip 134, the latter being provided at suitably spaced intervals along its length with downwardly opening semi-circular notches 135.

Provided for closurewise association with the counter A³ are two overlapping rectangular door panels 136, 137, provided in their lower margins with downwardly opening longitudinal grooves 138, 139, respectively, for sliding engagement with upwardly projecting cylindrical nylon plugs 91', 92', the latter being substantially identical with and being structurally embodied in the counter A³ in substantially the same manner as the previously described nylon plugs 91, 92. The door panel 136 is provided on its rear face with upwardly projecting flat plates 140, 141, having horizontal pins 142, 143, equipped with rollers 144, 145, which slide in and along the upwardly presented faces of the track-forming channel 133. The plates 140, 141 are also provided with forwardly projecting pins 146, 147, which are located in downwardly spaced parallel relation to the pins 142, 143, and barely clear the downwardly presented longitudinal margin of the lip 134. Thus, if the door 136 is lifted upwardly the pins 146, 147 will contact the downwardly presented longitudinal margin of the lip 134 and prevent the rollers 144, 145 from coming out of the track-forming channel 133. If, however, the door 136 is shifted to such a position that the pins 146, 147 will be in vertical alignment with the semi-circular notches 135 the door 136 may be lifted up high enough to permit the rollers 144, 145 to be slid onto or out of the track-forming channel 133.

Similarly, the door panel 137 is provided upon its rear face with offset brackets 148, 149, having pins 150, 151, provided with rollers 152, 153 for operative disposition within the track-forming channel 133. The offset brackets 148, 149 are also provided with forwardly projecting pins 154, 155, which are similar in location, shape, and function to the previously described pins 146, 147.

It is also possible to provide another modified form of counter installation, such as the counter A⁴ as shown in FIGS. 17 and 18. The counter A⁴ is substantially identical with the previously described counter installation A¹ and differs therefrom and is provided with a single length of roller-track 156 which integrally includes a back web 157, a flat top flange 158, and a V-shaped

6

bottom or track-forming channel 159 provided on its forwardly and upwardly presented longitudinal margin with an integral upstanding marginal lip 160 having a pair of suitably spaced upwardly opening rectilinear notches 161, 162, which are substantially similar in purpose and function to the previously described rectilinear notches 114, 115, of the roller-track 109. Provided for operative rolling support upon the roller-track 156 are door panels 116', 117', which are substantially identical in all respects to the previously described door panels 116, 117.

It should be understood that changes and modifications in the form, construction, arrangement, and combination of the several parts of the counters and sliding closures therefor, may be made and substituted for those herein shown and described without departing from the nature and principle of my invention.

Having thus described my invention, what I claim and desire to secure by Letters Patent is:

1. A counter having a top, a front wall, a rear wall, and side walls co-operatively arranged to form a hollow open-bottomed storage compartment, a partition-element adjacent to each of the side walls and positioned so as to define a side-pocket and a storage compartment within the counter beneath the top, said rear wall having an access-opening communicating with the storage compartment, a carrier slidably mounted in said side-pocket, a door hingedly mounted on the carrier by means of a long piano-type hinge, said door being adapted normally to extend closure-wise across the access-opening and also being adapted to swing out into a position in line with the path of movement of the carrier and thence be shifted inwardly into substantially concealed position within the side-pocket, a laterally projecting flange coplanar with said door and rigidly attached to said piano-type hinge adjacent said door and extending vertically along the line of its hinged connection with the carrier for swinging outwardly and being sized to conceal the opening of the side-pocket when the door is in closure-forming position, and a depending abutment member mounted across the upper margin of the access-opening for stop-forming engagement with the door when the latter is in closure-forming position.

2. A counter having a top, a front wall, a rear wall, and side walls co-operatively arranged to form a hollow open-bottomed storage compartment, a partition-element adjacent to each of the side walls and positioned so as to define a side-pocket and a storage compartment within the counter beneath the top, said rear wall having an access-opening communicating with the storage compartment, a horizontal slide channel mounted in said pocket in parallel relation to the side walls, said channel having an upwardly opening V-shaped track portion and a top flange spaced upwardly therefrom, a carrier slidably mounted in said side-pocket, roller-wheels having substantially flat rolling surfaces being mounted on the carriage for shifting movement along the track portion of the channel, a door hingedly mounted on the carrier by means of a long piano-type hinge, said door being adapted normally to extend closure-wise across the access-opening and also being adapted to swing out into a position in line with the path of movement of the carrier and thence be shifted inwardly into substantially concealed position within the side-pocket, and a laterally projecting flange coplanar with said door and rigidly attached to said piano-type hinge adjacent said door, said flange also extending vertically along the line of its hinged connection with the carrier for swinging outwardly and being sized to conceal the opening of the side-pocket when the door is in closure-forming position.

3. A counter having a top, a front wall, a rear wall, and side walls co-operatively arranged to form a hollow open-bottomed storage compartment, a partition-element adjacent to each of the side walls and positioned so as to define a side-pocket and a storage compartment within the counter beneath the top, said rear wall having an access-

7

opening communicating with the storage compartment, a horizontal slide channel mounted in said pocket in parallel relation to the side walls, said channel having an upwardly opening V-shaped track portion and a top flange spaced upwardly therefrom, said top flange being provided with at least one slot, a carrier slidably mounted in said side-pocket, roller-wheels having substantially flat rolling surfaces being mounted on the carriage for shifting movement along the track portion of the channel, a door hingedly mounted on the carrier by means of a long piano-type hinge, said door being adapted normally to extend closure-wise across the access-opening and also being adapted to swing out in a position in line with the path of movement of the carrier and thence be shifted inwardly into substantially concealed position within the side-pocket, and a laterally projecting flange coplanar with said door and rigidly attached to said piano-type hinge adjacent said door, said flange also extending vertically along the line of its hinged connection with the carrier for swinging outwardly and being sized to conceal the opening of the side-pocket when the door is in closure-forming position.

4. A counter having a top, a front wall, a rear wall, and side walls co-operatively arranged to form a hollow open-bottomed storage compartment, a partition-element adjacent to each of the side walls and positioned so as to define a side-pocket and a storage compartment within the counter beneath the top, said rear wall having an access-opening communicating with the storage compartment, a horizontal slide channel mounted in said pocket in parallel relation to the side walls, said channel having an upwardly opening V-shaped track portion, a carrier slidably mounted in said side-pocket, roller-wheels having substantially flat rolling surfaces being mounted on the carriage for shifting movement along the track portion of the channel, a door hingedly mounted on the carrier by means of a long piano-type hinge, said door being adapted normally to extend closure-wise across the access-opening and also being adapted to swing out into a position in line with the path of movement of the carrier and thence be shifted inwardly into substantially concealed position within the side-pocket, and a laterally projecting flange coplanar with said door and rigidly attached to said piano-type hinge adjacent said door, said flange also extending vertically along the line of its hinged connection with the carrier for swinging outwardly and being sized to conceal the opening of the side-pocket when the door is in closure-forming position.

5. A counter having a top, a front wall, a rear wall, and side walls co-operatively arranged to form a hollow open-bottomed storage compartment, a partition-element adjacent to each of the side walls and positioned so as to define a side-pocket and a storage compartment within the counter beneath the top, said rear wall having an access-opening communicating with the storage compartment, a horizontal slide channel mounted in said pocket in parallel relation to the side walls, said channel having an upwardly opening V-shaped track portion and a top flange spaced upwardly therefrom, said top flange being provided with a pair of longitudinally spaced slots, a carrier slidably mounted in said side-pocket, roller-wheels having substantially flat rolling surfaces being mounted on the carriage for shifting movement along the track portion of the channel, a door hingedly mounted on the carrier by means of a long piano-type hinge, said door being adapted normally to extend closure-wise across the access-opening and also being adapted to swing out into a position in line with the path of movement of the carrier and thence be shifted inwardly into substantially concealed position within the side-pocket, and a laterally projecting flange coplanar with said door and rigidly attached to said piano-type hinge adjacent said door, said flange also extending vertically along the line of its hinged connection with the carrier for swinging outwardly and being sized to conceal the opening of

8

the side-pocket when the door is in closure-forming position.

6. A counter having a top, a front wall, a rear wall, and side walls co-operatively arranged to form a hollow open-bottomed storage compartment, a partition-element adjacent to each of the side walls and positioned so as to define a side-pocket and a storage compartment within the counter beneath the top, said rear wall having an access-opening communicating with the storage compartment, a horizontal slide channel mounted in said pocket in parallel relation to the side walls, said channel having an upwardly opening V-shaped track portion and a top flange spaced upwardly therefrom, said top flange being provided with a pair of longitudinally spaced slots, a carrier slidably mounted in said side-pocket, upwardly projecting plates on the carrier, roller-wheels having substantially flat rolling surfaces being journaled on the plates and adapted for shifting movement along the track portion of the channel, pins mounted on the plates and projecting outwardly therefrom for roller-retentive cooperation with the flange, said pins also being shiftable into the slots for permitting removal of the roller-wheels from the track portion, a door hingedly mounted on the carrier by means of a long piano-type hinge, said door being adapted normally to extend closure-wise across the access-opening and also being adapted to swing out into a position in line with the path of movement of the carrier and thence be shifted inwardly into substantially concealed position within the side-pocket, and a laterally projecting flange coplanar with said door and rigidly attached to said piano-type hinge adjacent said door, said flange also extending vertically along the line of its hinged connection with the carrier for swinging outwardly and being sized to conceal the opening of the side-pocket when the door is in closure-forming position.

7. A counter having a top, a front wall, a rear wall, and side walls co-operatively arranged to form a hollow open-bottomed storage compartment, a partition-element adjacent to each of the side walls and positioned so as to define a side-pocket and a storage compartment within the counter beneath the top, said rear wall having an access-opening communicating with the storage compartment, a horizontal slide channel mounted in said pocket in parallel relation to the side walls, said channel having an upwardly opening V-shaped track portion, a flange extending along said track portion, said flange being provided with a pair of longitudinally spaced slots, a carrier slidably mounted in said side-pocket, roller-wheels having substantially flat rolling surfaces being mounted on the carriage for shifting movement along the track portion of the channel, a door hingedly mounted on the carrier by means of a long piano-type hinge, said door being adapted normally to extend closure-wise across the access-opening and also being adapted to swing out into a position in line with the path of movement of the carrier and thence be shifted inwardly into substantially concealed position within the side-pocket, and a laterally projecting flange coplanar with said door and rigidly attached to said piano-type hinge adjacent said door, said flange also extending vertically along the line of its hinged connection with the carrier for swinging outwardly and being sized to conceal the opening of the side-pocket when the door is in closure-forming position.

8. A counter having a top, a front wall, a rear wall, and side walls co-operatively arranged to form a hollow open-bottomed storage compartment, a partition-element adjacent to each of the side walls and positioned so as to define a side-pocket and a storage compartment within the counter beneath the top, said rear wall having an access-opening communicating with the storage compartment, a horizontal slide channel mounted in said pocket in parallel relation to the side walls, said channel having an upwardly opening V-shaped track portion, a flange extending along said track portion, said flange being provided with a pair of longitudinally spaced slots, a carrier

9

slidably mounted in said side-pocket, upwardly projecting plates on the carrier, roller-wheels having substantially flat rolling surfaces being journaled on the plates and adapted for shifting movement along the track portion of the channel, pins mounted on the plates and projecting outwardly therefrom for roller-retentive co-operation with the flange, said pins also being shiftable into the slots for permitting removal of the roller-wheels from the track portion, a door hingedly mounted on the carrier by means of a long piano-type hinge, said door being adapted normally to extend closure-wise across the access-opening and also being adapted to swing out into a position in line with the path of movement of the carrier and thence be shifted inwardly into substantially concealed position within the side-pocket, and a laterally projecting flange coplanar with said door and rigidly attached

5

10

15

10

to said piano-type hinge adjacent said door, said flange also extending vertically along the line of its hinged connection with the carrier for swinging outwardly and being sized to conceal the opening of the side-pocket when the door is in closure-forming position.

References Cited in the file of this patent

UNITED STATES PATENTS

790,916	Pederson	May 30, 1905
840,061	Hofman	Jan. 1, 1907
2,375,581	Pezzano	May 8, 1945
2,482,855	Lloyd	Sept. 27, 1949
2,807,835	Weise	Oct. 1, 1957
2,867,488	Guild	Jan. 6, 1959
2,893,049	Guerrant	July 7, 1959