

(12) INTERNATIONAL APPLICATION PUBLISHED UNDER THE PATENT COOPERATION TREATY (PCT)

(19) World Intellectual Property Organization
International Bureau



(43) International Publication Date
10 July 2003 (10.07.2003)

PCT

(10) International Publication Number
WO 03/056190 A1

- (51) International Patent Classification⁷: F15D 1/12, B64C 23/06, F42B 10/00
- (21) International Application Number: PCT/AU03/00003
- (22) International Filing Date: 3 January 2003 (03.01.2003)
- (25) Filing Language: English
- (26) Publication Language: English
- (30) Priority Data:
PR 9827 3 January 2002 (03.01.2002) AU
PS 1352 26 March 2002 (26.03.2002) AU
- (71) Applicant (for all designated States except US): PAX SCIENTIFIC, INC. [US/US]; 93 Crestwood Drive, San Rafael, CA 94901 (US).
- (72) Inventor; and
(75) Inventor/Applicant (for US only): HARMAN, Jayden, David [AU/AU]; Research Vessel "PAX", Fremantle Fishing Boat Harbour, South Fremantle, Western Australia 6162 (AU).
- (74) Agent: WRAY & ASSOCIATES; Level 4, The Quadrant, 1 William Street, Perth, Western Australia 6000 (AU).
- (81) Designated States (national): AE, AG, AL, AM, AT, AU, AZ, BA, BB, BG, BR, BY, BZ, CA, CH, CN, CO, CR, CU, CZ, DE, DK, DM, DZ, EC, EE, ES, FI, GB, GD, GE, GH, GM, HR, HU, ID, IL, IN, IS, JP, KE, KG, KP, KR, KZ, LC, LK, LR, LS, LT, LU, LV, MA, MD, MG, MK, MN, MW, MX, MZ, NO, NZ, OM, PH, PL, PT, RO, RU, SC, SD, SE, SG, SK, SL, TJ, TM, TN, TR, TT, TZ, UA, UG, US, UZ, VC, VN, YU, ZA, ZM, ZW.
- (84) Designated States (regional): ARIPO patent (GH, GM, KE, LS, MW, MZ, SD, SL, SZ, TZ, UG, ZM, ZW),

[Continued on next page]

(54) Title: VORTEX RING GENERATOR

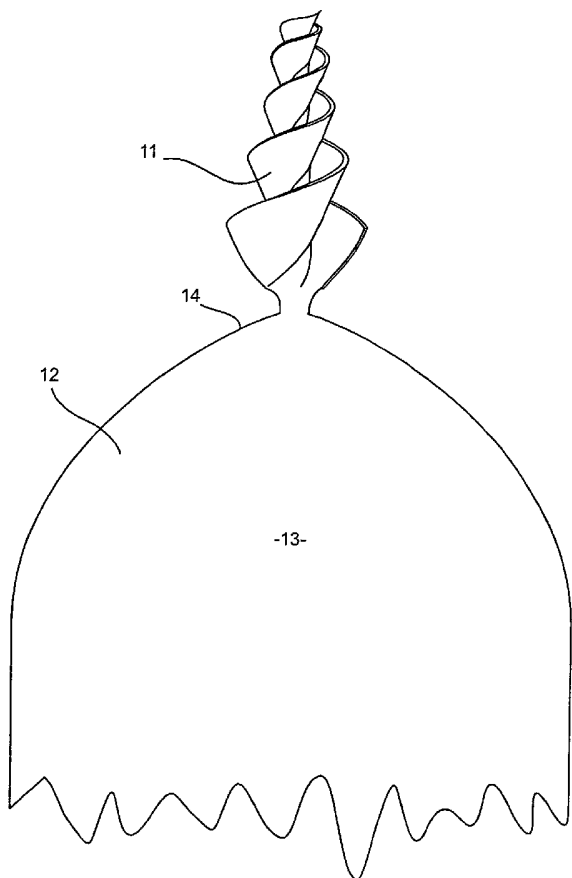

(57) Abstract: A vortex ring generator (11) adapted to be associated with a body (12) subjected to fluid flow, the vortex ring generator (11) being adapted to produce a fluid flow in the form of a vortex ring with the fluid flow moving over the body from the vortex ring generator (11).





Eurasian patent (AM, AZ, BY, KG, KZ, MD, RU, TJ, TM),
European patent (AT, BE, BG, CH, CY, CZ, DE, DK, EE,
ES, FI, FR, GB, GR, HU, IE, IT, LU, MC, NL, PT, SE, SI,
SK, TR), OAPI patent (BF, BJ, CF, CG, CI, CM, GA, GN,
GQ, GW, ML, MR, NE, SN, TD, TG).

For two-letter codes and other abbreviations, refer to the "Guidance Notes on Codes and Abbreviations" appearing at the beginning of each regular issue of the PCT Gazette.

Published:

— *with international search report*

Vortex Ring Generator

Field of the Invention

The present invention relates to the field of fluid mechanics and more particularly to the flow of a fluid relative to a body. More particularly, this invention seeks to reduce
5 drag on a body or fuselage during relative movement of the body with respect to a fluid.

The invention is described herein by reference to its use in respect to any mobile body or fuselage, such as, including, but not limited to, projectiles, missiles, torpedoes, submarines and aircraft. However, the invention is not restricted to
10 mobile fuselages, but may also be used to reduce drag on stationary bodies such as buildings, bridge pilings, and fixed obstacles in watercourses, airways or other fluid flow fields. Such applications are intended to be within the scope of the invention although not specifically described herein.

Background Art

15 The greatest obstacle to obtaining optimum efficiency in streamlining a fuselage is surface friction. This can be in several forms but typically is one of or a combination of boundary layer drag, skin friction, viscosity, surface tension, cavitation and turbulence.

Existing technologies seek to reduce this drag and optimise the energy efficiency of
20 a moving body or fuselage by altering its surface to be as smooth as possible with the least possible protuberances or alternatively to roughen the smooth surface or to give it a rippling surface similar to that of a shark, dolphin or golf ball.

The objective is to minimise the effects of drag from fluids flowing past.

- 2 -

Another attempt to cut drag has included the fitting of small vortex generators to wings and other parts of the fuselage.

A further attempt has been to fit a spike-like protuberance extending forwardly in the direction of travel of the fuselage through the fluid.

- 5 In general, it has been an objective of these attempts to maintain straight, laminar flow over the body of the fuselage, and to suppress separation or turbulence as far as is possible. Alternatively, through the use of dimpled or roughen surfaces and vortex generators, the objective has been to create myriad eddies in close proximity to the fuselage surface to break up the boundary layer.
- 10 Essentially, all these approaches are designed to assist fluids slide past the body with a minimum of friction.

Disclosure of the Invention

- It is an object of the invention to reduce the drag of a fluid moving relative to a body. It is a further object of this invention to enable the body to take advantage of the
15 extraordinary efficiency of the vortex ring.

To this end, a body, for example a torpedo or rocket, is fitted with a vortex ring generator according to the invention, either at the nose of the body and/or around the body.

- The objective is to produce a vortex ring at the nose of the body that conveys the
20 fluid flow past the body while simultaneously creating a low-pressure region immediately in front of the nose. This low-pressure region is in fact, the core of the ring vortex.

A generated vortex ring moves relative to the fluid of which it is comprised and it cross-sectionally rolls, much like a wheel, rather than slides. Famed

- 3 -

hydrodynamisist, Reynolds once stated, in reference to ring vortices, that "Nature prefers to roll rather than glide".

It is this feature that greatly contributes to ring vortex efficiency.

5 Presently used vortex generators are comprised of small tabs of straight or curved material, such as those situated above the leading edges of wings on aircraft. These generate turbulence fields of eddies that flow across the surface of the wing.

10 This invention is specifically designed to generate vortex rings which surround the body to enable the fluid flowing past the body to do so within the generated vortex ring. Preferably, such generators are specifically designed in accordance with the Golden Section or Phi geometry. Phi geometry has been found to represent the path of least resistance, friction or drag in Nature and is also the shape of naturally occurring vortices.

15 Accordingly, the invention resides in a vortex ring generator adapted to be associated with a body subjected to fluid flow over the body, the vortex ring generator adapted to produce a fluid flow in the form of a vortex ring with the fluid flow moving over the body from the vortex ring generator.

According to a preferred feature of the invention, the vortex ring generator is designed in accordance with the Golden Section or Phi geometry.

20 According to a preferred feature of the invention, the vortex ring generator is centripetal in its action

25 According to a further aspect, the invention resides in a vortex ring generator comprising an element adapted to be associated with a body to influence the fluid flow passing over the body, the element comprising an active surface which is adapted to influence the fluid flow, the active surface having a configuration conforming to at least one logarithmic curve of the Golden Section.

- 4 -

According to a preferred embodiment, the vortex ring generator associated with the body and comprising one or more vanes having an active surface, the path of the vanes spiralling around and along the body.

5 According to a preferred embodiment, the vortex ring generator extends forwardly of the body.

According to a preferred embodiment, the vanes are in the form of a whorl.

According to a preferred feature of the invention, the active surfaces of the vanes are designed to conform to the Golden Section.

10 According to a preferred embodiment, the path of the vanes are designed to conform to the Golden Ratio.

According to a preferred embodiment, the vortex ring generator comprises one or more grooves associated with the body, the path of the vanes spiralling around and along the body.

15 According to a preferred embodiment, the path of the grooves are designed to conform to the Golden Ratio.

According to a preferred embodiment, a vortex ring is generated by the body and vortex ring generator being caused to move through the fluid.

According to a preferred embodiment, a vortex ring is generated by the fluid moving past the vortex ring generator associated with a body

20 According to a preferred embodiment, a vortex ring generator is fixed relative to the body.

According to a preferred embodiment, a vortex ring generator is adapted to be movable relative to the body.

- 5 -

According to a preferred embodiment, a vortex ring is generated by movement of the vortex ring generator.

According to a preferred embodiment, a vortex ring is generated and propulsion is created by the powered rotation of the vortex ring generator.

- 5 The invention will be more fully understood in the light of the following description of several specific embodiments.

Brief Description of the Drawings

The description is made with reference to the accompanying drawings, of which:

Figure 1 illustrates the form of the Golden Section;

- 10 Figure 2 is a side elevation of a vortex ring generator according to the first embodiment;

Figure 3 is a front end view of a vortex ring generator according to the first embodiment;

- 15 Figure 4 is a rear end view of a vortex ring generator according to the first embodiment;

Figure 5 is a side elevation of a vortex ring generator mounted to a body according to the first embodiment;

Figure 6 is a side elevation of a vortex ring generator applied to a body according to the second embodiment;

- 20 Figure 7 is a front end view of a vortex ring generator applied to a body according to the second embodiment;

- 6 -

Figure 8 is a side elevation of a vortex ring generator applied to a body according to a third embodiment;

Figure 9 is a front end view of a vortex ring generator applied to a body according to the third embodiment;

5 Figure 10 is a diagrammatic representation of the flow of vortex rings around a body having vortex ring generator according to the first and third embodiments;

Figure 11 is a diagrammatic representation of the flow of vortex rings around a body having vortex ring generator according to the second embodiment;

10 Figure 12 is a diagrammatic representation of the generation of a vortex ring around by vortex ring generator according to the first embodiment;

Detailed Description of Specific Embodiments

Each of the embodiments comprises a vortex ring generator associated with a body and adapted to generate a vortex ring in the fluid moving relative to the body. In each embodiment, the vortex ring generator comprises a fluid pathway having an active surface adapted to influence the flow of the fluid to form the vortex rings flowing past the body.

15

As stated previously all fluids when moving under the influence of the natural forces of Nature, tend to move in spirals or vortices. These spirals or vortices generally comply with a mathematical progression known as the Golden Ratio or a Fibonacci like Progression.

20

The greater percentage of the surfaces of the active surfaces of each of the embodiments described herein are generally designed in the greater part, in accordance with the Golden Section or Ratio and therefore it is a characteristic of each of the embodiments that the active surfaces are of a spiralling configuration

- 7 -

and which conform at least in greater part to the characteristics of the Golden Section or Ratio. The characteristics of the Golden Section are illustrated in Figure 1 which illustrates the unfolding of the spiral curve according to the Golden Section or Ratio. As the spiral unfolds the order of growth of the radius of the curve which is measured at equiangular radii (eg E, F, G, H, I and J) is constant. This can be illustrated from the triangular representation of each radius between each sequence which corresponds to the formula of $a:b = b:a+b$ which conforms to the ratio of 1:0.618 approximately and which is consistent through out the curve.

A characteristic of the embodiments is that not only do the X and Y axis conform to Golden Section geometry, but also the Z axis or depth conforms, that is the vanes conform to the Golden Section in three dimensions.

It is an objective of the embodiments to duplicate the lines of vorticity found in a ring vortex. To that end, the active surfaces expand or contract logarithmically in any direction in an equiangular, Golden Section spiral. If any two points are taken on the surface of these active surfaces they will bear a ratio to each other of approximately 1 : 0.618. The active surfaces can be any length or number of rotations. They are specifically designed to match the internal, streamlined flow lines of vorticity of a vortex.

In the first embodiment, and as shown in Figures 2 to 5, the vortex ring generator (11) comprises a set of vanes located at the nose (13) of a body (12). In this specification, the term nose is used to identify the portion of the body which is intended to face the direction from which the relative flow of fluid is approaching the body.

The vortex ring generator (11) is adapted to generate a vortex ring by influencing the flow of the fluid relative to the body in a way which produces a vortex ring. The vanes comprising the vortex ring generator extend forwardly from the nose of the body and have the configuration of a whorl. Each of the vanes are formed with an internal reactive face (14) which is of a concave configuration and which has a three

- 8 -

dimensional curvature of a concave nature whereby the curvature in each direction is in accordance with a logarithmic curve conforming to the Golden Section. As a result, the vanes (11) jointly define a generally concave internal face of the vortex ring generator.

5 In addition, each vane has a remote reactive face (15) which is remote from the internal reactive face (14) and which also has a three dimensional curvature of a convex nature whereby the curvature in each dimension conforms with a logarithmic curve according to the Golden Section, and whereby the curvature in each dimension is of the same form as the curvature of the internal reactive face (14) in
10 each dimension. As a result, the remote reactive faces (15) jointly define a generally convex surface of the vanes.

In an adaptation of the first embodiment, the vortex ring generator is not fixedly mounted to the nose but rather is adapted to rotate coaxially with the axis of the body. In addition, the generator may be driven mechanically to rotate thereby
15 providing propulsion to the body whilst simultaneously generating vortex rings.

In the second embodiment, as shown in Figures 6 and 7, the vortex ring generator comprises a set one or more grooves or flutes (21) in the surface of the body, commencing at or near the nose (23) of the body (22) and ending at or near the tail (24) of the body . The paths of the grooves or flutes along the body spiral around
20 the body in a manner designed to conform to the Golden Ratio.

In the third embodiment, as shown in Figures 8 and 9, the vortex ring generator comprises a set one or more vanes (31) extending outwardly from the surface of the body, commencing at or near the nose (33) of the body (32) and ending at or near the tail (34) of the body. The paths of the vanes along the body spiral around the
25 body in a manner designed to conform to the Golden Ratio.

The body in each of the above embodiments is ideally designed in accordance with a logarithmic, equiangular, Phi spiral. Its shape is optimally compatible with Phi

- 9 -

vortex geometry, which is common to all vortices. In other words the body occupies that space which is seen in the cavitation tube of a visible vortex.

As depicted in Figure 11, the body, 13, is accommodated within the core of the vortex, 16. The nose of the body, by use of embodiment one, two or three above
5 exactly fits the geometry of a ring vortex. The body may be cone-shaped with a hollow centre allowing fluid incoming to the vortex ring to travel through its core.

Figures 10, and 11 illustrate the creation of ring vortices, 16, which travel/roll along the body.

In operation, with relative movement between the fluid and the body, the fluid is
10 engaged by the active surfaces 11, 21 or 31 and commences rotating in a logarithmic vortical fashion. As the fluid engages the active surfaces, the rotary motion creates a low-pressure area at the base of the vortex generator (the interface between the generator and the nose of the body). This reduces the boundary layer drag of the body. A ring and/or potential vortex is established. As can be seen in
15 Figure 10, the ring vortex rolls up the boundary layer like ball bearings, along the body walls. In many applications vortex rings will shed and give rise to a stream of shed vortex rings. The wake left behind the body is in the shape of vortex rings.

Figure 12 illustrates the vortex ring generator, 11 of the first embodiment creating a
20 ring vortex, 16. To do so, there must be relative motion between the vortex ring generator, 11, and the fluid.

This motion can be created by rotation of the vortex ring generator; the movement of fluid past a stationary vortex ring generator, or the propulsion of the body and vortex ring generator through the fluid.

It should be appreciated that the scope of the present invention need not be limited
25 to the particular scope described above.

- 10 -

Throughout the specification, unless the context requires otherwise, the word "comprise" or variations such as "comprises" or "comprising", will be understood to imply the inclusion of a stated integer or group of integers but not the exclusion of any other integer or group of integers.

The claims defining the invention are as follows:

1. A vortex ring generator adapted to be associated with a body subjected to fluid flow, the vortex ring generator being adapted to produce a fluid flow in the form of a vortex ring with the fluid flow within the vortex ring moving over the body from
5 the vortex ring generator.
2. A vortex ring generator as claimed at claim 1 wherein the vortex ring generator is designed in accordance with the Golden Section or Phi geometry.
3. A vortex ring generator as claimed at claim 1 or claim 2 wherein the vortex ring generator is centripetal in its action.
- 10 4. A vortex ring generator as claimed at any one of the preceding claims wherein the vortex ring generator being associated with the body and comprising at least one or more vanes having an active surface.
5. A vortex ring generator as claimed at claim 6 wherein the vortex ring generator extends forwardly from the body.
- 15 6. A vortex ring generator as claimed at claim 6 or claim 7 wherein the vanes are in the form of a whorl.
7. A vortex ring generator as claimed at any one of claims 6 to 8 wherein the active surfaces of the vanes are designed to conform to the Golden Section.
8. A vortex ring generator as claimed at any one of claims 1 to 5 wherein the
20 vortex ring generator comprises at one or more vanes associated with the surface of the body, the path of the vanes spiralling around the body and along the body.
9. A vortex ring generator as claimed at claim 10 wherein the path of the vanes are designed to conform to the Golden Ratio.

- 12 -

10. A vortex ring generator as claimed at any one of claims 1 to 5 wherein the vortex ring generator comprises at least one or more grooves associated with the surface of the body, the path of the grooves spiralling around the body and along the body.
- 5 11. A vortex ring generator as claimed at claim 12 wherein the path of the grooves are designed to conform to the Golden Ratio.
12. A vortex ring generator comprising an element adapted to be associated with a body to influence the fluid flow passing over the body, the element comprising an active surface which is adapted to influence the fluid flow, the active surface having
10 a configuration conforming to at least one logarithmic curve of the Golden Section.
13. A vortex ring generator as claimed at claim 13 wherein the curvature of the active surface conforms to the Golden Section.
14. A vortex ring generator wherein a vortex ring is generated by movement of a fluid past a stationary vortex ring generator.
- 15 15. A vortex ring generator wherein a vortex ring is generated by the movement of the body and vortex ring generator through a fluid.
16. A vortex ring generator wherein a vortex ring is generated by movement of the vortex ring generator.
17. A vortex ring generator wherein a vortex ring is generated and propulsion is
20 created by the powered rotation of the vortex ring generator.
18. A vortex ring generator substantially as herein described.
19. A vortex ring generator substantially as herein described with reference to the accompanying drawings.

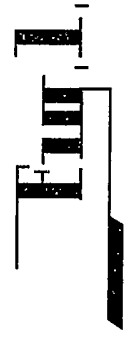
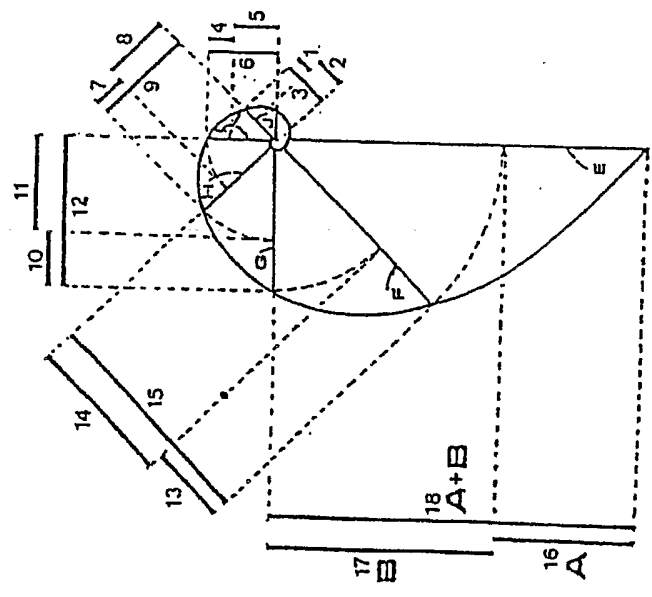
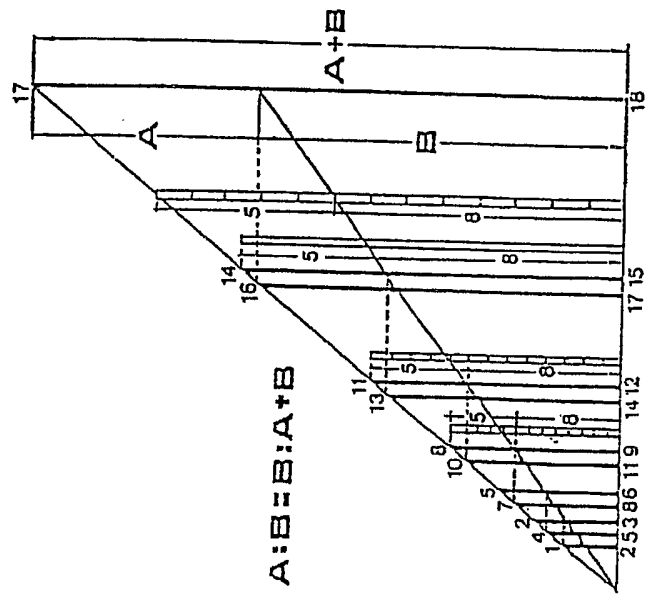
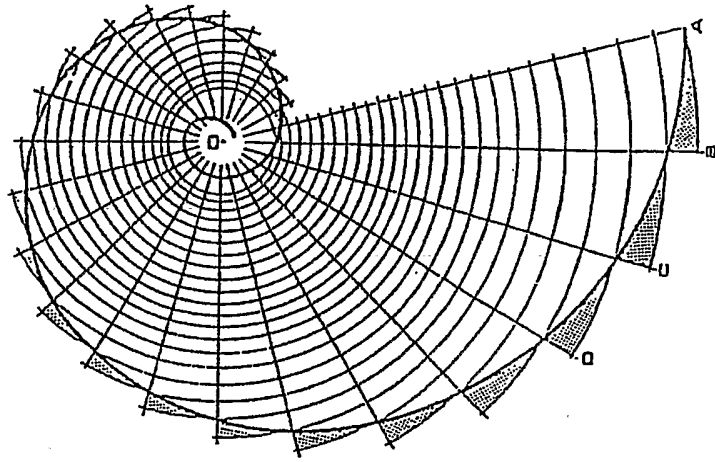

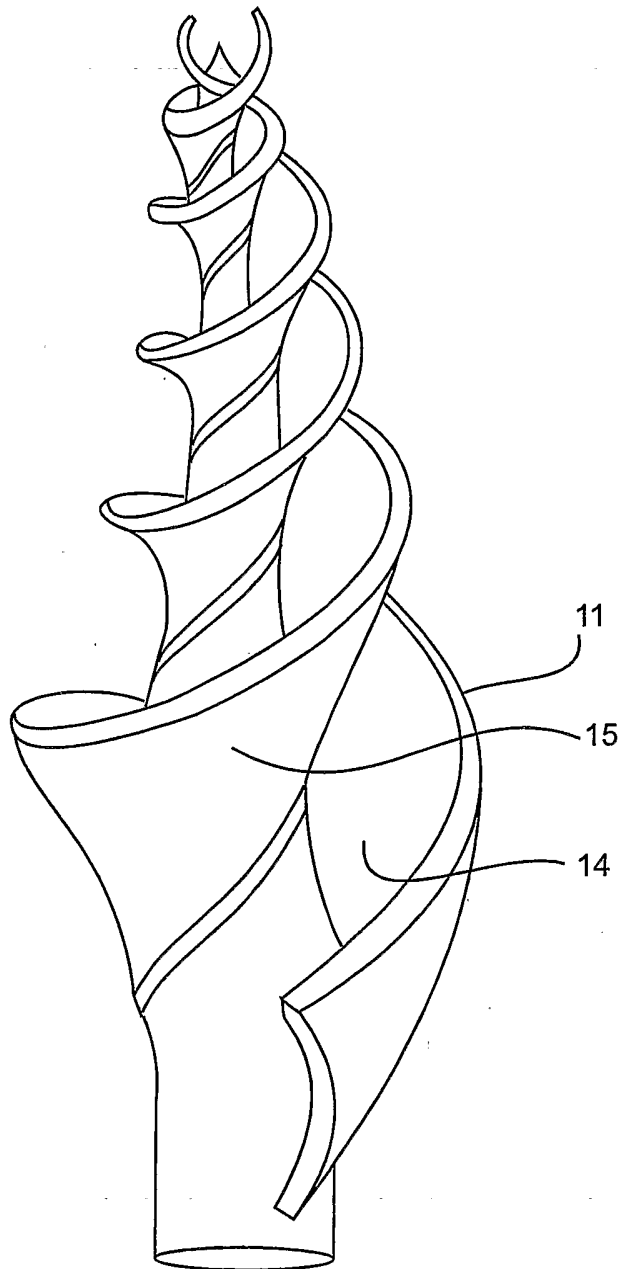

Fig. 2

3/7

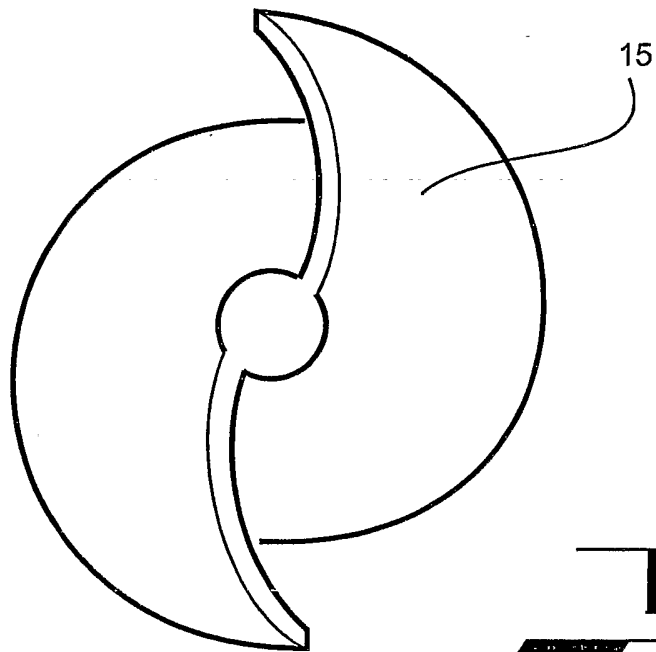

Fig. 3

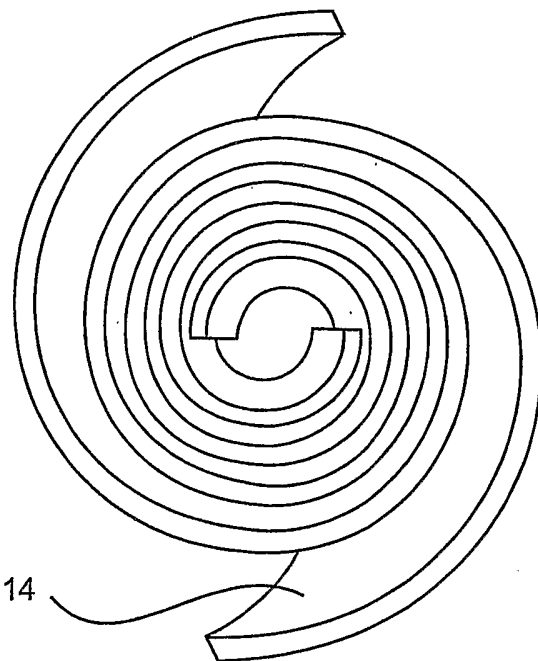

Fig. 4

4/7

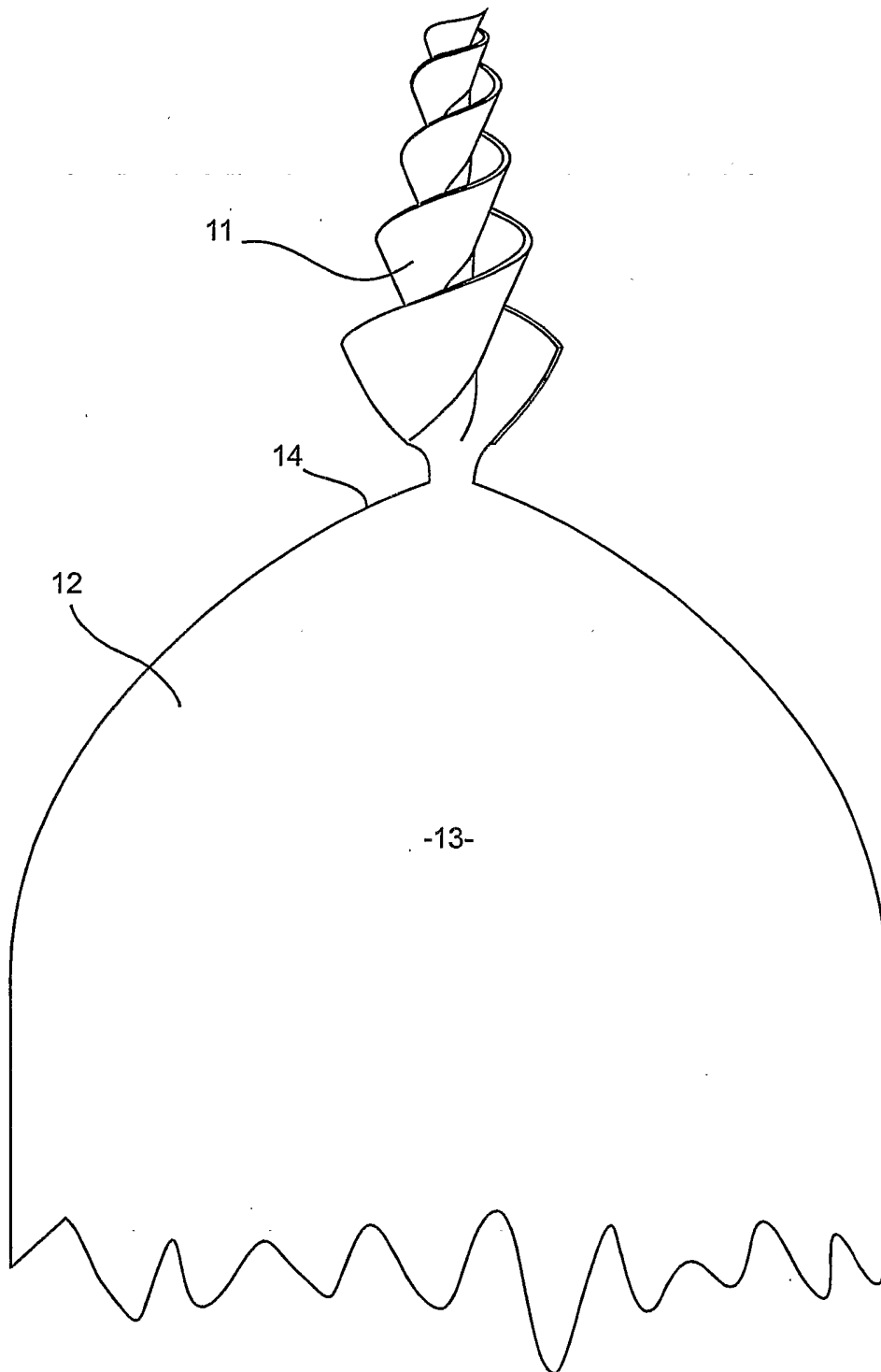

Fig. 5

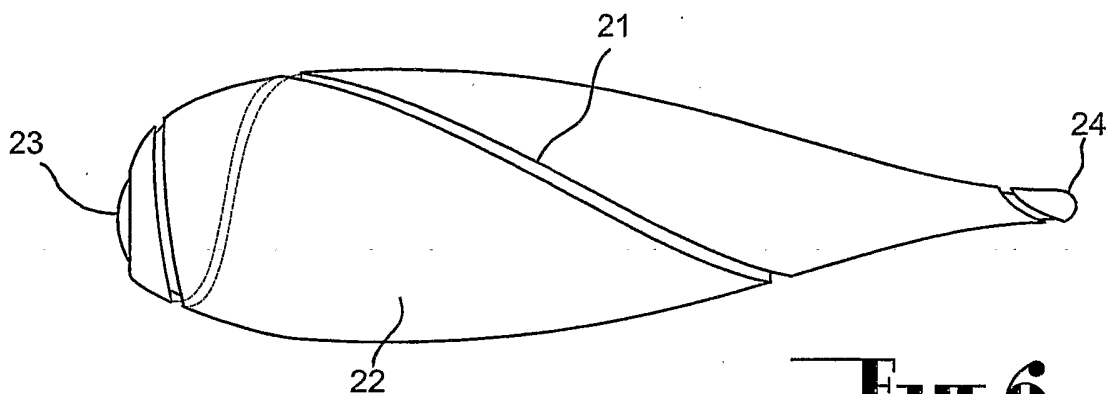

Fig. 6.

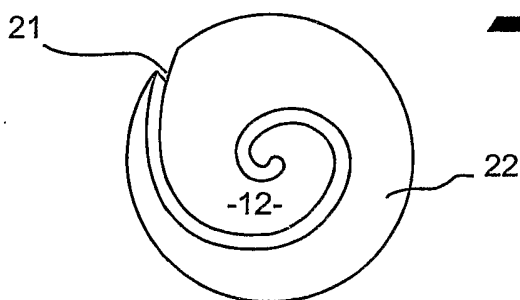

Fig. 7.

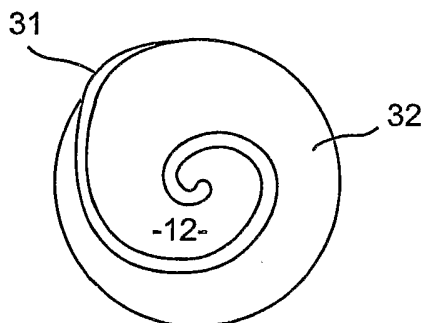

Fig. 8.

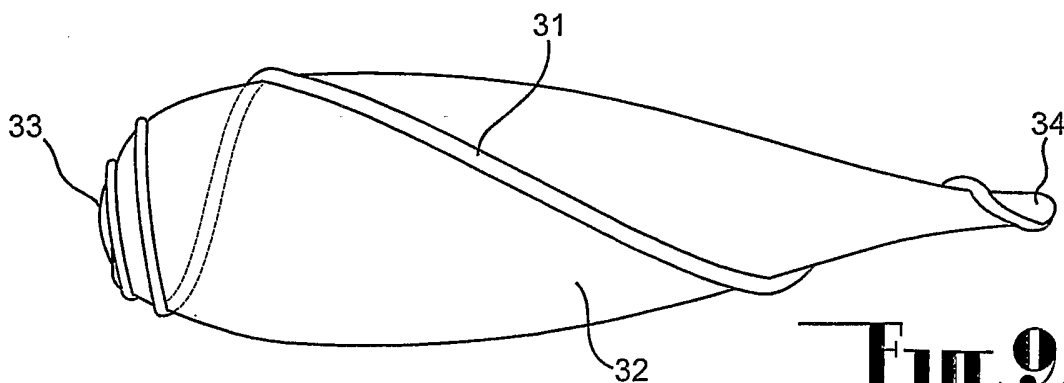

Fig. 9.

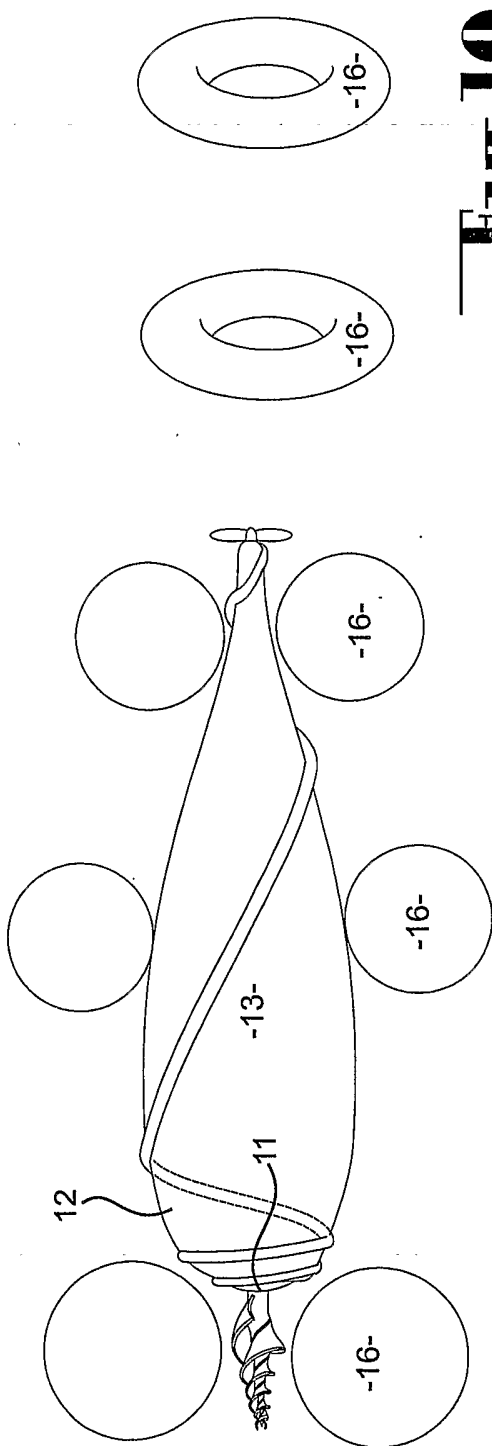

Fig. 10

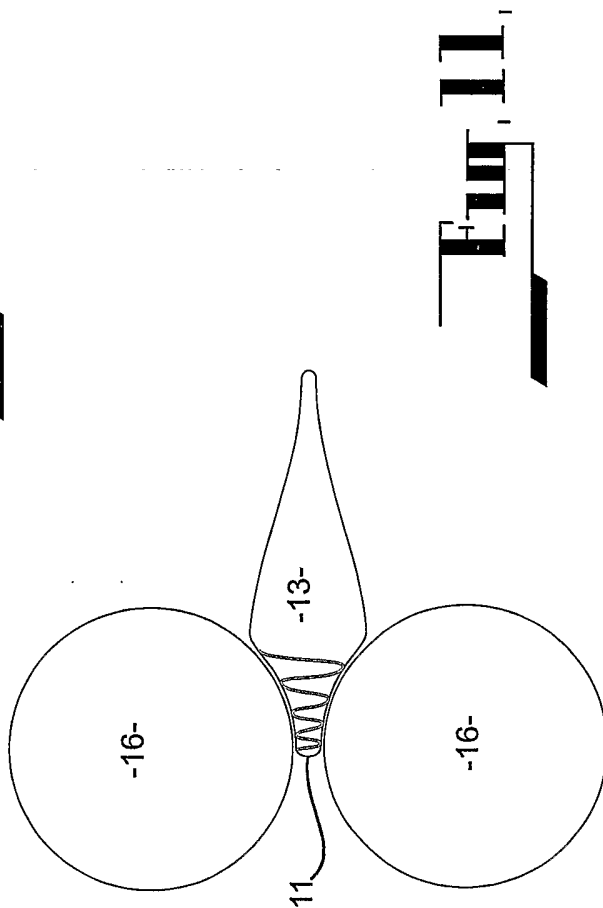

Fig. 11

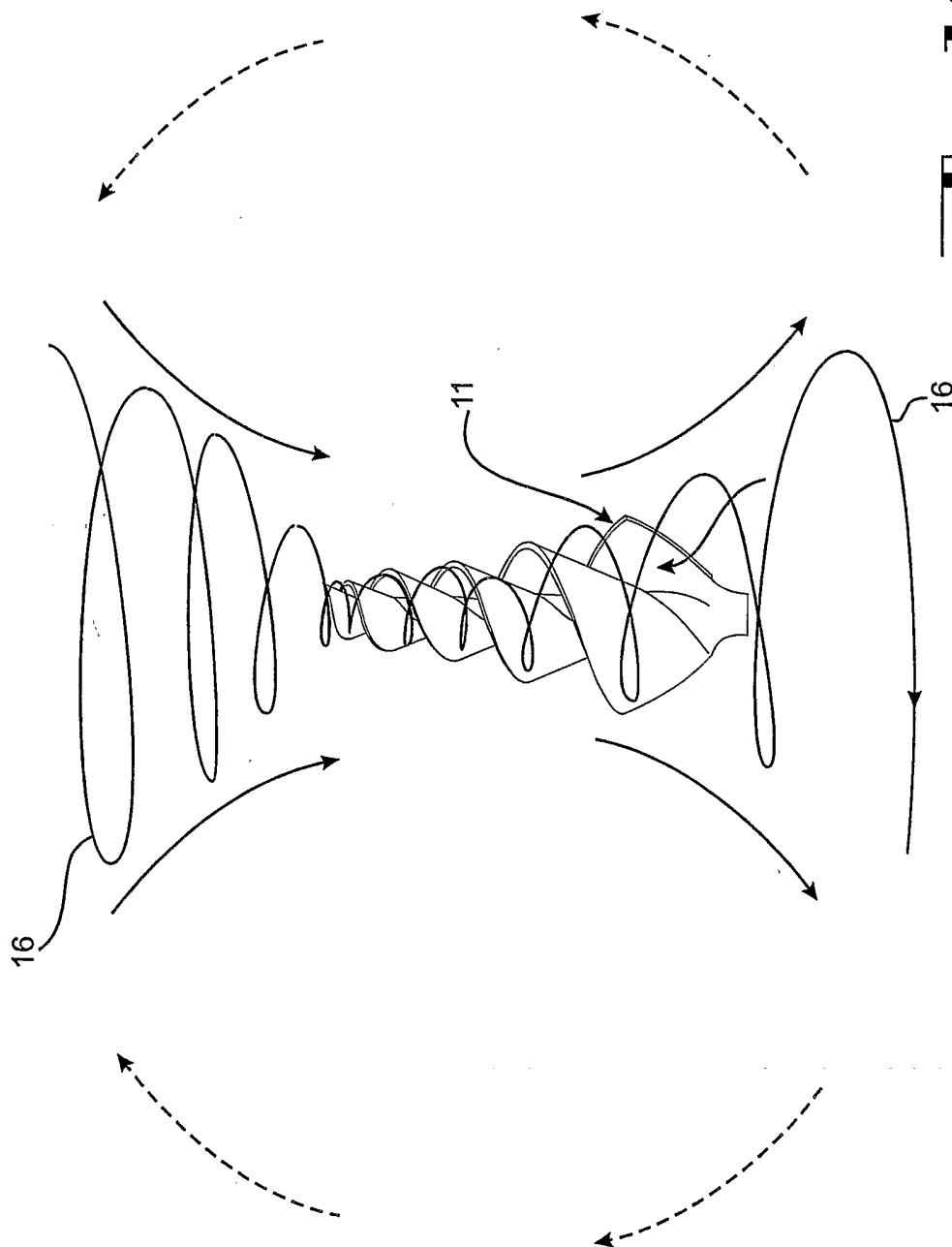

Fig. 12

INTERNATIONAL SEARCH REPORT

International application No.

PCT/AU03/00003

A. CLASSIFICATION OF SUBJECT MATTER		
Int. Cl. ⁷ : F15D 1/12, B64C 23/06, F42B 10/00		
According to International Patent Classification (IPC) or to both national classification and IPC		
B. FIELDS SEARCHED		
Minimum documentation searched (classification system followed by classification symbols) Refer electronic database consulted below		
Documentation searched other than minimum documentation to the extent that such documents are included in the fields searched		
Electronic data base consulted during the international search (name of data base and, where practicable, search terms used) DWPI - F15D 1/IC, B64C 21/IC, 23/IC, Q79/DC and Keywords vortex, vortex ring, generator and similar terms		
C. DOCUMENTS CONSIDERED TO BE RELEVANT		
Category*	Citation of document, with indication, where appropriate, of the relevant passages	Relevant to claim No.
X	EP 283307 B1 (LATTO) 24 May 1995 Whole document	14-16
X	US 3940060 A (VIETS) 24 February 1976 Whole document	14-16
X	Derwent Abstract Accession No 87-318963/45, Class Q56, SU 1291726 A (MAKEEVKA ENG CONS) 23 February 1987 Whole document	14-16
<input checked="" type="checkbox"/> Further documents are listed in the continuation of Box C <input checked="" type="checkbox"/> See patent family annex		
* "A"	Special categories of cited documents: document defining the general state of the art which is not considered to be of particular relevance	"T" later document published after the international filing date or priority date and not in conflict with the application but cited to understand the principle or theory underlying the invention
"E"	earlier application or patent but published on or after the international filing date	"X" document of particular relevance; the claimed invention cannot be considered novel or cannot be considered to involve an inventive step when the document is taken alone
"L"	document which may throw doubts on priority claim(s) or which is cited to establish the publication date of another citation or other special reason (as specified)	"Y" document of particular relevance; the claimed invention cannot be considered to involve an inventive step when the document is combined with one or more other such documents, such combination being obvious to a person skilled in the art
"O"	document referring to an oral disclosure, use, exhibition or other means	"&" document member of the same patent family
"P"	document published prior to the international filing date but later than the priority date claimed	
Date of the actual completion of the international search 27 February 2003		Date of mailing of the international search report 13 MAR 2003
Name and mailing address of the ISA/AU AUSTRALIAN PATENT OFFICE PO BOX 200, WODEN ACT 2606, AUSTRALIA E-mail address: pct@ipaaustralia.gov.au Facsimile No. (02) 6285 3929		Authorized officer R. SUBBARAYAN Telephone No : (02) 6283 2377

INTERNATIONAL SEARCH REPORT

International application No.

PCT/AU03/00003

C (Continuation). DOCUMENTS CONSIDERED TO BE RELEVANT		
Category*	Citation of document, with indication, where appropriate, of the relevant passages	Relevant to claim No.
X	JP 2000168632 A (TAKASHI) 20 June 2000 Abstract on Espacenet and figures	14-16
A	US 5139215 A (PECKHAM) 18 August 1992	
A	US 5207397 A (NG et al) 4 May 1993	
A	US 5058837 A (WHEELER) 22 October 1991	
A	Derwent Abstract Accession No 99-249047/21, Class Q51 Q57 Q75 Q78, JP 11072104 A (SAITO JDOSHA SHATAI KOGYO KK) 16 March 1999	
A	US 5934877 A (HARMAN) 10 August 1999	

INTERNATIONAL SEARCH REPORT

Information on patent family members

International application No.

PCT/AU03/00003

This Annex lists the known "A" publication level patent family members relating to the patent documents cited in the above-mentioned international search report. The Australian Patent Office is in no way liable for these particulars which are merely given for the purpose of information.

Patent Document Cited in Search Report		Patent Family Member					
EP	283307	CA	1314041	US	5100242		
US	3940060	NONE					
US	5139215	CA	1314764	DE	3342861	FR	2666786
		GB	2244968	IT	1235222	SE	8306496
US	5207397	NONE					
US	5058837	CA	2014014	EP	466826	WO	9011929
US	5934877	AU	62946/96	CA	2226486	CN	1193377
		EP	837989	IL	122889	WO	9703291
END OF ANNEX							