

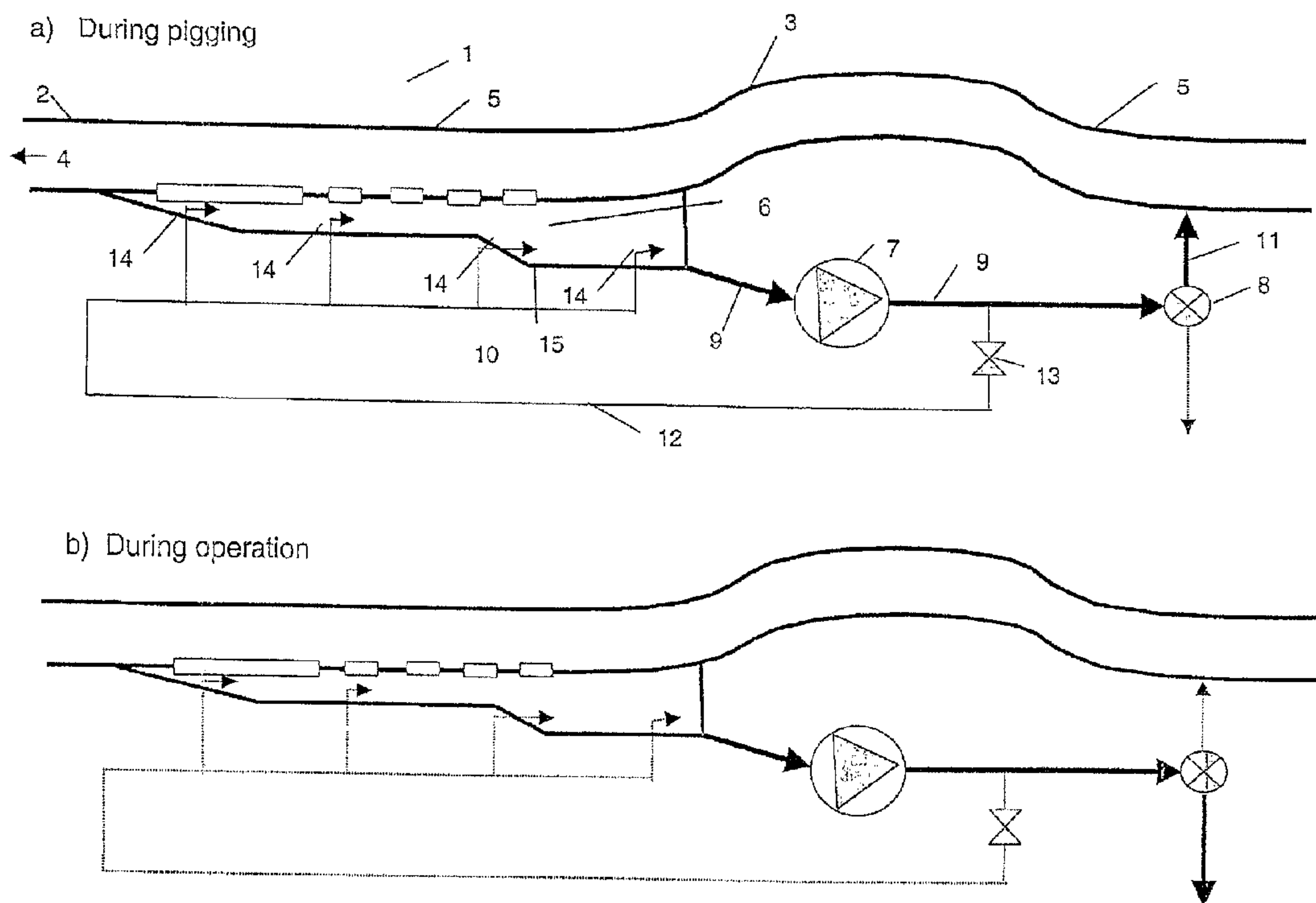

(86) Date de dépôt PCT/PCT Filing Date: 2006/03/15
 (87) Date publication PCT/PCT Publication Date: 2006/09/21
 (45) Date de délivrance/Issue Date: 2011/07/19
 (85) Entrée phase nationale/National Entry: 2007/09/10
 (86) N° demande PCT/PCT Application No.: NO 2006/000096
 (87) N° publication PCT/PCT Publication No.: 2006/098636
 (30) Priorité/Priority: 2005/03/16 (NO20051388)

(51) Cl.Int./Int.Cl. *E21B 43/34* (2006.01),
B08B 9/04 (2006.01), *F16L 55/26* (2006.01)
 (72) Inventeurs/Inventors:
GRAMME, PER EIVIND, NO;
LIE, GUNNAR HANNIBAL, NO
 (73) Propriétaire/Owner:
NORSK HYDRO ASA, NO
 (74) Agent: FETHERSTONHAUGH & CO.

(54) Titre : DISPOSITIF POUR LE NETTOYAGE D'UN SEPARATEUR DE CONDUITES
 (54) Title: ARRANGEMENT FOR THE CLEANING OF A PIPE SEPARATOR



(57) **Abrégé/Abstract:**

Device or arrangement for cleaning a pipe separator (1) where the separator body (2) consists of an extended, tubular body with an inlet (4) and an outlet (5) having essentially the same diameter as the separator body. At the outlet, there's a bend or a loop (3) designed to maintain a fluid level in the separator. Just before the bend, there's an outlet (6) with an outlet pipe (9) for fluid, e.g. water, from the separator. Sand or other particulate materials introduced into the outlet (6) are returned, using a pump (7) arranged on the outlet pipe (9), together with fluid from the outlet, to the separator after the bend (3) by means of reversal with a valve (8) via a return pipe (11); in connection with the outlet (6), there's a flushing device comprising a pipe loop (12) connected to the outlet pipe (9) for the return of fluid from the outlet to the nozzles (14) arranged in the outlet, designed to flush in direction downstream of the outlet, any particles having accumulated in the outlet chamber.

(12) INTERNATIONAL APPLICATION PUBLISHED UNDER THE PATENT COOPERATION TREATY (PCT)

(19) World Intellectual Property Organization
International Bureau



(43) International Publication Date
21 September 2006 (21.09.2006)

PCT

(10) International Publication Number
WO 2006/098636 A1

(51) International Patent Classification:

E21B 43/34 (2006.01) *F16L 55/26* (2006.01)
B08B 9/04 (2006.01)

(21) International Application Number:

PCT/NO2006/000096

(22) International Filing Date: 15 March 2006 (15.03.2006)

(25) Filing Language: English

(26) Publication Language: English

(30) Priority Data:

20051388 16 March 2005 (16.03.2005) NO

(71) Applicant (for all designated States except US): **NORSK HYDRO ASA** [NO/NO]; N-0204 Oslo (NO).

(72) Inventors; and

(75) Inventors/Applicants (for US only): **GRAMME, Per, Eivind** [NO/NO]; Steinringen 12, N-3931 Porsgrunn (NO). **LIE, Gunnar, Hannibal** [NO/NO]; Korpeliveien 13, N-3928 Porsgrunn (NO).

(74) Agent: **HOFSETH, Svein**; Patent and Trademark Department, Hydro Aluminium AS, N-0240 Oslo (NO).

(81) Designated States (unless otherwise indicated, for every kind of national protection available): AE, AG, AL, AM, AT, AU, AZ, BA, BB, BG, BR, BW, BY, BZ, CA, CH, CN, CO, CR, CU, CZ, DE, DK, DM, DZ, EC, EE, EG, ES, FI, GB, GD, GE, GH, GM, HR, HU, ID, IL, IN, IS, JP, KE, KG, KM, KN, KP, KR, KZ, LC, LK, LR, LS, LT, LU, LV, LY, MA, MD, MG, MK, MN, MW, MX, MZ, NA, NG, NI, NO, NZ, OM, PG, PH, PL, PT, RO, RU, SC, SD, SE, SG, SK, SL, SM, SY, TJ, TM, TN, TR, TT, TZ, UA, UG, US, UZ, VC, VN, YU, ZA, ZM, ZW.

(84) Designated States (unless otherwise indicated, for every kind of regional protection available): ARIPO (BW, GH, GM, KE, LS, MW, MZ, NA, SD, SL, SZ, TZ, UG, ZM, ZW), Eurasian (AM, AZ, BY, KG, KZ, MD, RU, TJ, TM), European (AT, BE, BG, CH, CY, CZ, DE, DK, EE, ES, FI, FR, GB, GR, HU, IE, IS, IT, LT, LU, LV, MC, NL, PL, PT, RO, SE, SI, SK, TR), OAPI (BF, BJ, CF, CG, CI, CM, GA, GN, GQ, GW, ML, MR, NE, SN, TD, TG).

Published:

— with international search report

For two-letter codes and other abbreviations, refer to the "Guidance Notes on Codes and Abbreviations" appearing at the beginning of each regular issue of the PCT Gazette.

(54) Title: ARRANGEMENT FOR THE CLEANING OF A PIPE SEPARATOR

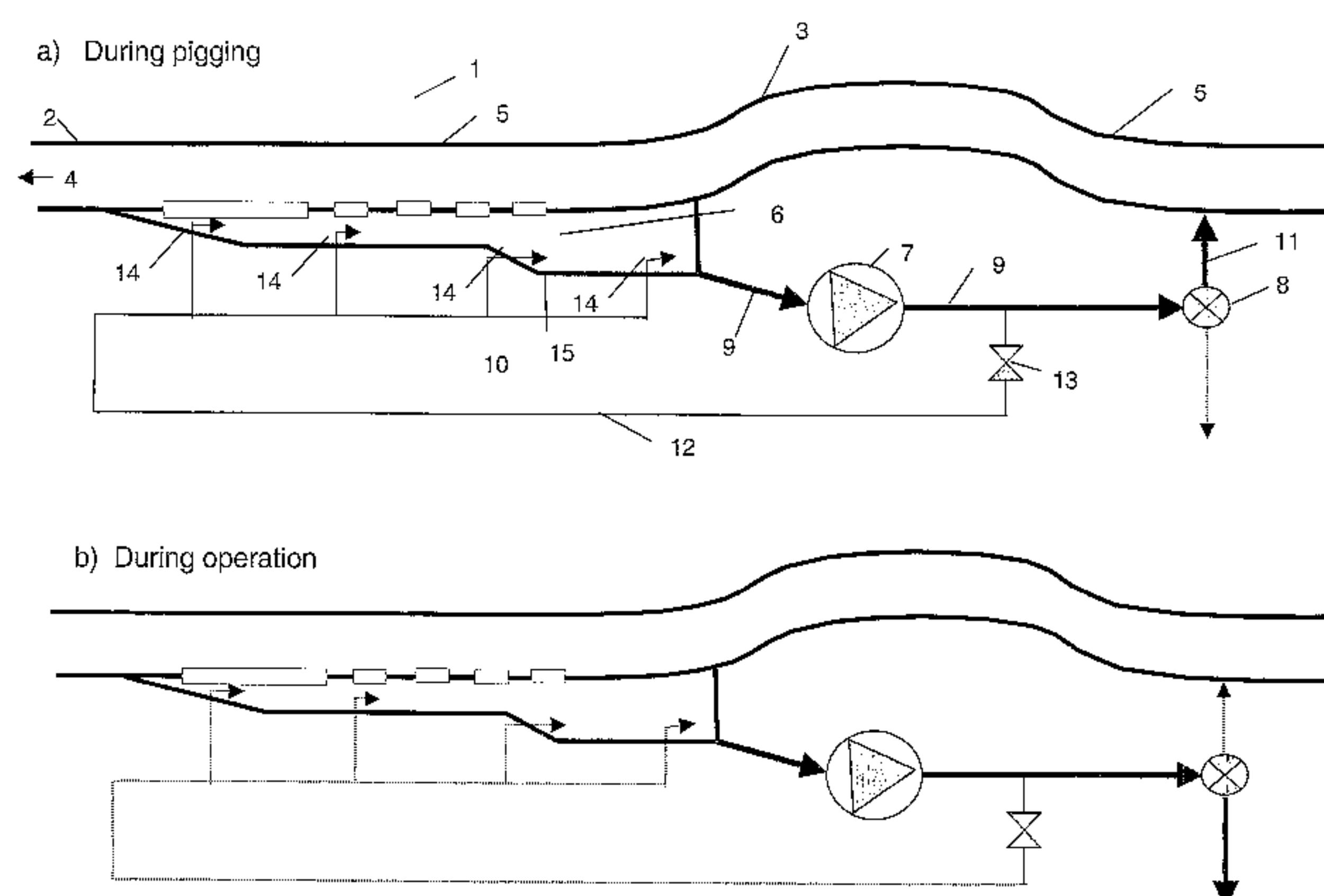

(57) Abstract: Device or arrangement for cleaning a pipe separator (1) where the separator body (2) consists of an extended, tubular body with an inlet (4) and an outlet (5) having essentially the same diameter as the separator body. At the outlet, there's a bend or a loop (3) designed to maintain a fluid level in the separator. Just before the bend, there's an outlet (6) with an outlet pipe (9) for fluid, e.g. water, from the separator. Sand or other particulate materials introduced into the outlet (6) are returned, using a pump (7) arranged on the outlet pipe (9), together with fluid from the outlet, to the separator after the bend (3) by means of reversal with a valve (8) via a return pipe (11); in connection with the outlet (6), there's a flushing device comprising a pipe loop (12) connected to the outlet pipe (9) for the return of fluid from the outlet to the nozzles (14) arranged in the outlet, designed to flush in direction downstream of the outlet, any particles having accumulated in the outlet chamber.

WO 2006/098636 A1

5

10

Arrangement for the cleaning of a pipe separator

The present invention concerns a device or an arrangement for cleaning a pipe separator in which the separator body consists of an extended, tubular body with an inlet at one end and an outlet at the other end. The inlet and the outlet have essentially the same diameter as the separator body and, at the outlet, there is a bend or a loop that is designed to maintain a fluid level in the separator, and, just ahead of the bend, an outlet for fluid, for example water, from the separator.

20 Separators of this kind are previously known from the prior art, including the applicant's own international patent application, PCT/NO 03/00265. However, the patent application in question contains no solutions for how the separator is to be cleaned.

In particular in connection with the production of oil and gas, large or small quantities of sand and deposits will be produced, depending on the composition of the subterranean formation, which must be removed. In a separator of the above type that is used for the separation of water from the oil/gas produced, deposits may accumulate in places that a conventional reamer or pig cannot reach. This will apply, in particular, to the water outlet of the separator.

27446-66

2

The present invention represents a solution for the cleaning of a separator of the above type that is simple and functional and that is inexpensive to produce and use.

5 An aspect of the present invention is characterised in that sand particles or other particulate materials that are introduced into the outlet before the bend are designed to be returned to the separator after the bend by means of reversal with a valve via a return pipe, as specified herein.

10 In accordance with an aspect of the invention, there is provided an apparatus comprising a pipe separator with a separator body consisting of an extended, tubular body with an inlet at one end and an outlet at the other end, wherein the inlet and the outlet have essentially the same diameter as the separator body and, at the outlet, there is provided a bend or a loop for maintaining a fluid level in the separator, and wherein just upstream of the bend or loop, there is provided an outlet with an outlet pipe for fluid from the separator, wherein sand
15 particles or other particulate materials that are accumulated at the outlet upstream of the bend or loop are returned, using a pump arranged on the outlet pipe, together with the fluid from the outlet, to the separator downstream of the bend or loop by means of reversal with a valve via a return pipe; and in connection with the outlet, there is provided a flushing device comprising a pipe loop connected to the outlet
20 pipe for returning fluid from the outlet to nozzles arranged in the outlet, the flushing device being arranged to flush, in a direction downstream of the outlet, any particles that may have accumulated in the outlet.

25 In accordance with another aspect of the invention, there is provided a method of using the apparatus described in the previous paragraph comprising allowing fluid to pass through the outlet pipe of the outlet.

The present invention will be described in further detail in the following using examples and with reference to the attached drawings, where:

Fig. 1 shows a drawing of a separator with a flushing device in accordance with the present invention during reaming, a), and during operation, b).

27446-66

2a

Fig. 2 shows a) a drawing of a pig or reamer in accordance with the present invention and a drawing of part of the separator shown in Fig. 1, over its outlet, with a reamer or pig (shown in Fig. 2 a)), which is designed to be used to clean the separator in accordance with the present invention.

5 Fig. 3 shows a drawing of part of a separator with a sleeve for covering the opening for the water outlet in the separator; Fig. 3 a) shows an axially displaceable sleeve and Fig. 3 b) shows a rotating sleeve.

Fig. 4 shows a) a drawing of a separator during operation and b) the same separator during cleaning.

Fig. 1 a) shows, as stated above, a drawing of a separator 1 for separation of a fluid, ideally oil/gas/water, in accordance with the present invention. It comprises a tubular body 2 (the entire length is not shown) with an inlet 4, an outlet 5, a bend 3 arranged in connection with the outlet and an outlet for water 6 arranged ahead of the bend 3. A pump 7 is arranged on the outlet pipe 9, downstream of the water outlet, to pump water that is separated from the separator on to a purification device (not shown) or for reinjection into an oil/gas reservoir, as shown in Fig. 1 b).

To prevent sludge and particles from being deposited in the water outlet, the water outlet is equipped with a flushing system 10, which comprises a reversing valve 8 arranged on the outlet pipe 9 and a reversing pipe 11 in connection with it, plus a return pipe 12 with a return valve 13 connected to the outlet pipe 9 ahead of the reversing valve 8. As shown in Fig. 1 a), the solution involves the water phase from the water outlet 6 with accumulated sludge/sand being reversible using the reversing valve 8 arranged on the outlet pipe 9, being fully or partially pumped, using the pump 7, back to the outlet pipe 5 after the separator via a reversing pipe 11, and being fully or partially returned, by opening the return valve, via the return pipe 12 to nozzles 14 in the water outlet 6, which are designed to flush sand and sludge located in the outlet chamber 15 downstream of the outlet towards the outlet pipe 9.

This flushing system can be in operation during the reaming operation, as shown and commented on in further detail in connection with Fig. 2 below, or, as required, in connection with the accumulation of sand or sludge at any time during the operation of the separator.

An appropriate electronic/electric control system is used to control the flushing system, i.e. to open and close the valves, 8 and 13. This system will not be described here. Furthermore, to ensure that this water cannot cause a hydrate problem in the pipe downstream, hydrate inhibitor must be added to the pipe. This will not be described here either.

Fig. 2 a) shows a drawing of a pig or reamer 16, which is designed to be used to clean a separator in accordance with the present invention. It consists of an extended, flexible or articulated body, which will be able to pass through the water outlet part 6 (see Fig. 1) of a pipe separator without the outlet being covered and closed during the pigging operation. The reamer 16 consists of a standard reamer head 17 with a rear drive plate 18 connected to the reamer head via a flexible or articulated, extended body 19, which, in turn, may be fitted, along the central part, with support plates or centring plates 20. Normally, the reamer will be driven by the fluid pressure that acts on the rear drive plate 18. This pressure will be maintained until the rear drive plate reaches the beginning of the opening 21 in the water outlet, as shown in Fig. 2 b). When the drive plate is located over the opening of the water outlet, the water outlet ducts will short-circuit the rear drive plate so that it could have stopped moving. At this point, the pig head has passed the water outlet and has full fluid pressure on its rear. This will move the pig on until the rear drive plate reaches the end of the water outlet. This will then take over the propulsion of the pig again. The aim of this solution is to design the reamer with sufficient length and with sealing for the reamer head so that the reamer can pass the water outlet without stopping.

The extended body is, as stated above, either flexible or articulated, but has sufficient support against the pipe wall via the support plates 20 to allow the reamer to pass through the fluid seal and any bent parts of the pipe separator.

The above solution with a long reamer is customised so that the reamer can pass through the opening 21 of the water outlet.

Figs. 3 a) and b) respectively show two alternative systems for covering the opening in the water outlet 6 to allow conventional reamers (which are normally too short in length) to be used to clean the pipe separator. The outlet 21 is covered here when the reamer passes the outlet to prevent the bypass of drive fluid.

To cover the opening, it is possible to use either a rotating (Fig. 3 a)) or longitudinally displaceable (Fig 3 b)) sleeve 22 that is driven by means of an actuator (not shown).

27446-66

5

An alternative, simple method for cleaning a pipe separator is to increase the flow rate through the pipe separator for a short period at fixed intervals (for example 5 minutes every 24 hours). This method is shown in Figs. 4 a) and b) and is based on the same principle as that shown in Fig. 1. However, as shown in Fig. 4 b), there is also an alternative return pipe loop 23 from the reversing valve 8 and back to the inlet 4 of the separator. The water from the outlet passes, in this solution, from the pump 7 via the return pipe back to the separator inlet.

The flow rate must be increased to such an extent that the sand particles are redispersed and transported out of the pipe separator with the fluid phase (oil + water). It is important for hydrate inhibitor to be added to this water to prevent possible hydrate formation in the downstream outlet pipe from the separator.

The table below shows the result of model calculations based on test results associated with particle transport (sand transport) in pipes, depending on the flow rate for different particle sizes. It is important for the flow rate (fluid speed) to reach the area in which the sand particles are dispersed in the fluid (i.e. E - entrained; see the middle column of the table).

27446-66

5a

Particle Transport in Pipe separator

Sand particle size (μm)	Superficial liquid velocity, V_l , (m/s)	Mode of sand transport	Hold-up of sand (-)	Height of stationary sand bed (m)
40	> 0.5	E	0	0
40	0,5	E	0	0
40	0,45	M	0	0
40	0,4	M	0	0
40	0,35	S	0,017	0,0257
40	0,3	S	0,149	0,111
30	> 0,45	E	0	0
30	0,45	E	0	0
30	0,4	M	0	0
30	0,35	M	0	0
30	0,3	S	0,112	0,091
20	> 0,40	E	0	0
20	0,4	E	0	0
20	0,35	M	0	0
20	0,3	S	0,042	0,0467
15	> 0,4	E	0	0
15	0,4	E	0	0
15	0,35	M	0	0
15	0,3	M	0	0
15	0,25	S	0,149	0,111

Ref. data:	Sand density	2565 kg/m ³	
	Pipe diameter	0,54 m	24" schedule 80
	Pipe inclination	0 deg.	
	Pipe wall roughness	2,50E-05	

Abbreviations:

E:	All particles are entrained
M:	Moving sand dunes or scouring particles
S:	Stationary sand bed

27446-66

5b

If this method is used, the system must still be designed for reaming (pigging), but the intervals between pigging operations are considerably increased, for example to once a year.

27446-66

6

CLAIMS:

1. An apparatus comprising a pipe separator with a separator body consisting of an extended, tubular body with an inlet at one end and an outlet at the other end, wherein the inlet and the outlet have essentially the same diameter as the separator body and, at the outlet, there is provided a bend or a loop for maintaining a fluid level in the separator, and wherein just upstream of the bend or loop, there is provided an outlet with an outlet pipe for fluid from the separator,
- 5
- wherein sand particles or other particulate materials that are accumulated at the outlet upstream of the bend or loop are returned, using a pump arranged on the outlet pipe, together with the fluid from the outlet, to the separator downstream of the bend or loop by means of reversal with a valve via a return pipe; and in connection with the outlet, there is provided a flushing device comprising a pipe loop connected to the outlet pipe for returning fluid from the outlet to nozzles arranged in the outlet, the flushing device being arranged to flush, in a direction downstream of the outlet, any particles that may have accumulated in the outlet.
- 10
- 15
2. The apparatus in accordance with claim 1, wherein a cover device in the form of a sleeve, which can rotate or be displaced longitudinally and which is designed to cover the outlet while the separator is being reamed, is arranged in connection with the outlet.
- 20
3. The apparatus in accordance with claim 1 or 2, wherein the apparatus further comprises another return pipe in connection with the valve, which is connected to the separator inlet, so that fluid from the outlet can be returned to the inlet and thus increase the fluid flow in the separator.
- 25
4. The apparatus in accordance with claim 3, wherein the apparatus is arranged such that the flushing of the outlet and the increased flow through the separator can be performed alternately.
5. The apparatus in accordance with any one of claims 1 to 4, wherein a flexible, extended reamer are used to ream the separator.

27446-66

7

6. A method of using an apparatus as claimed in any one of claims 1 to 5 comprising allowing fluid to pass through the outlet pipe of the outlet.
7. The method as claimed in claim 6, further comprising returning fluid from the outlet to the nozzles.
- 5 8. The method as claimed in claim 6 or 7, further comprising flushing, in a direction downstream of the outlet, any particles that may have accumulated in the outlet.
9. The method as claimed in any one of claims 6 to 8, comprising covering the outlet while the separator is being reamed.
- 10 10. The method as claimed in any one of claims 6 to 9, comprising returning fluid from the outlet to the inlet.
11. The method as claimed in any one of claims 6 to 10, comprising alternately flushing the outlet and returning fluid from the outlet to the inlet.
- 15 12. The method as claimed in any one of claims 6 to 11, comprising reaming the separator.
13. The method as claimed in claim 12, wherein the separator is reamed with a flexible extended reamer.

Fig 2

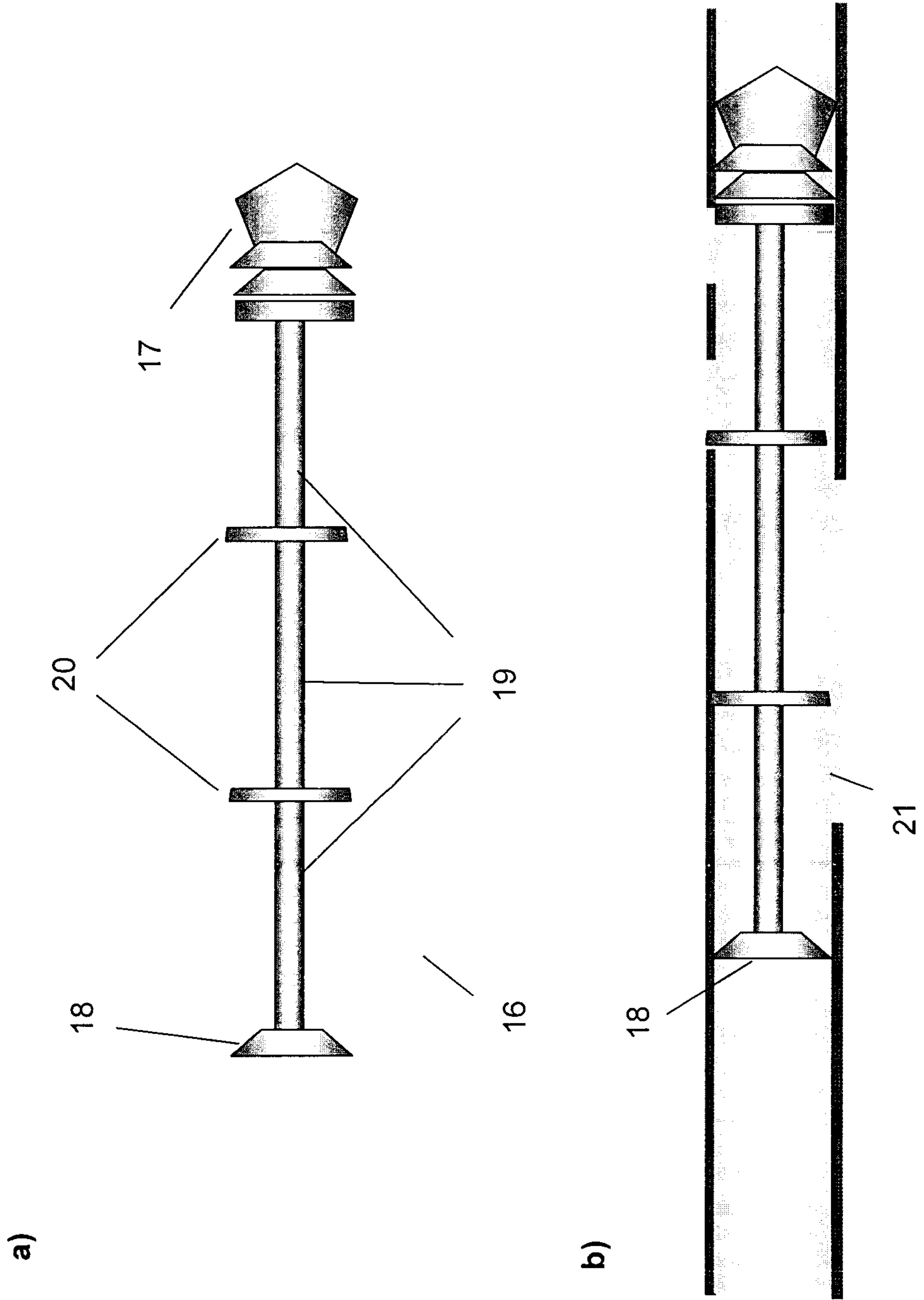

Fig 3

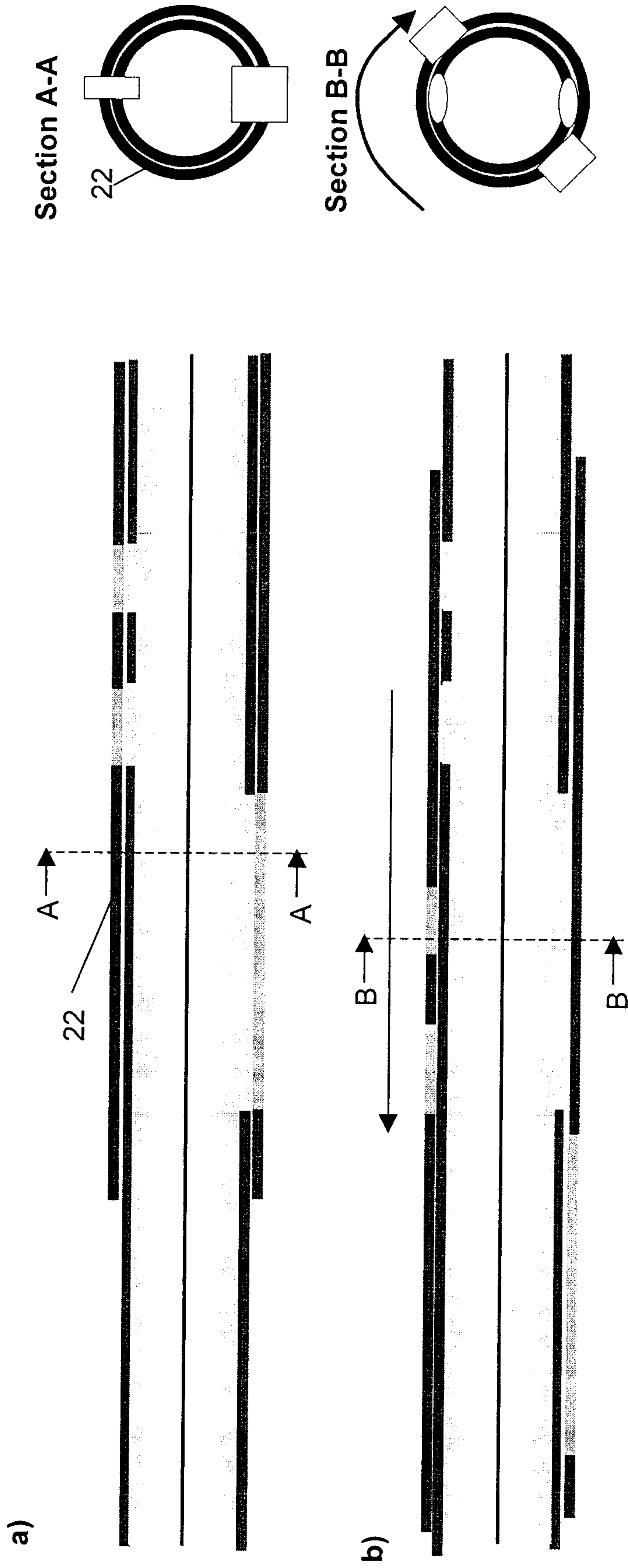
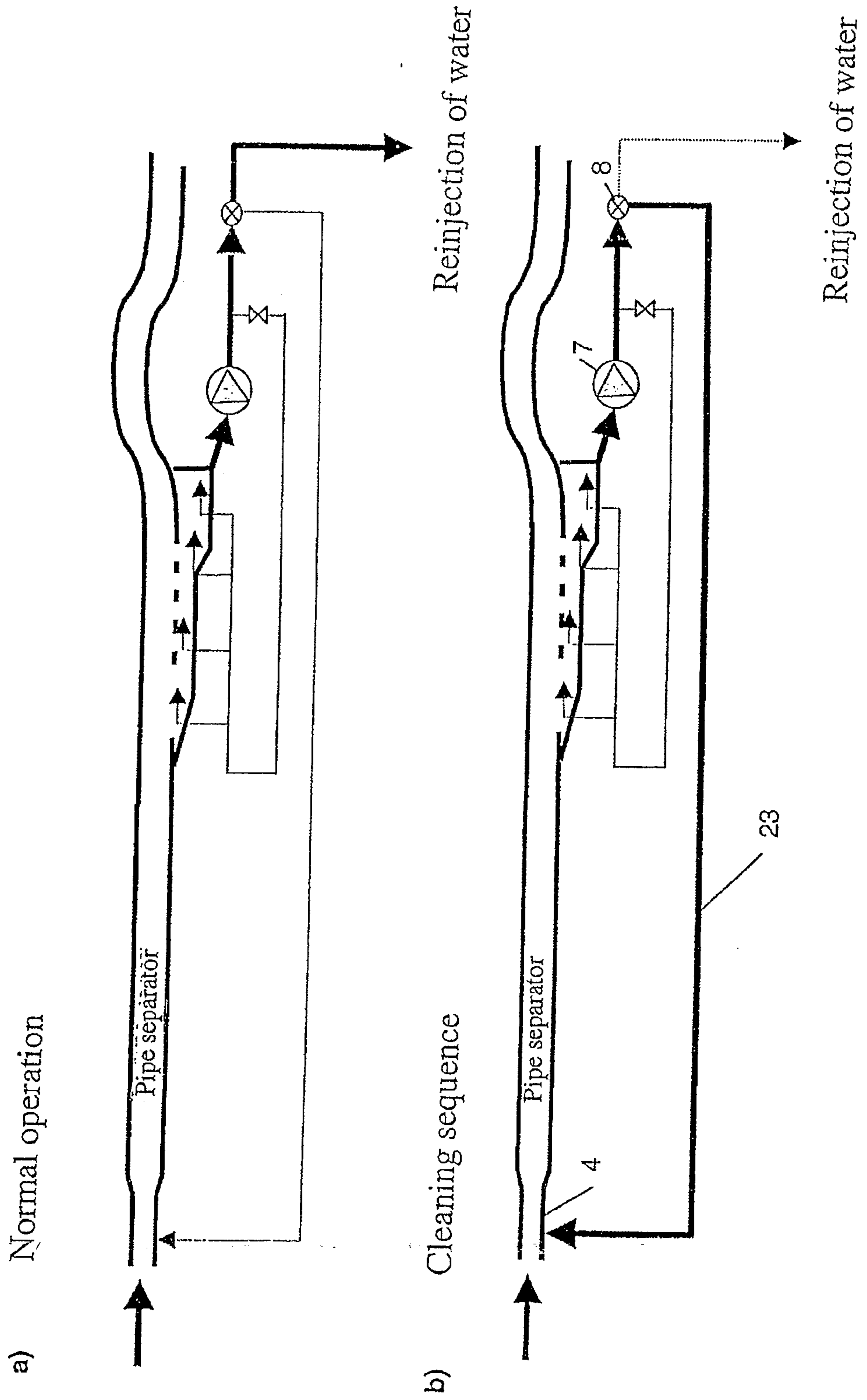
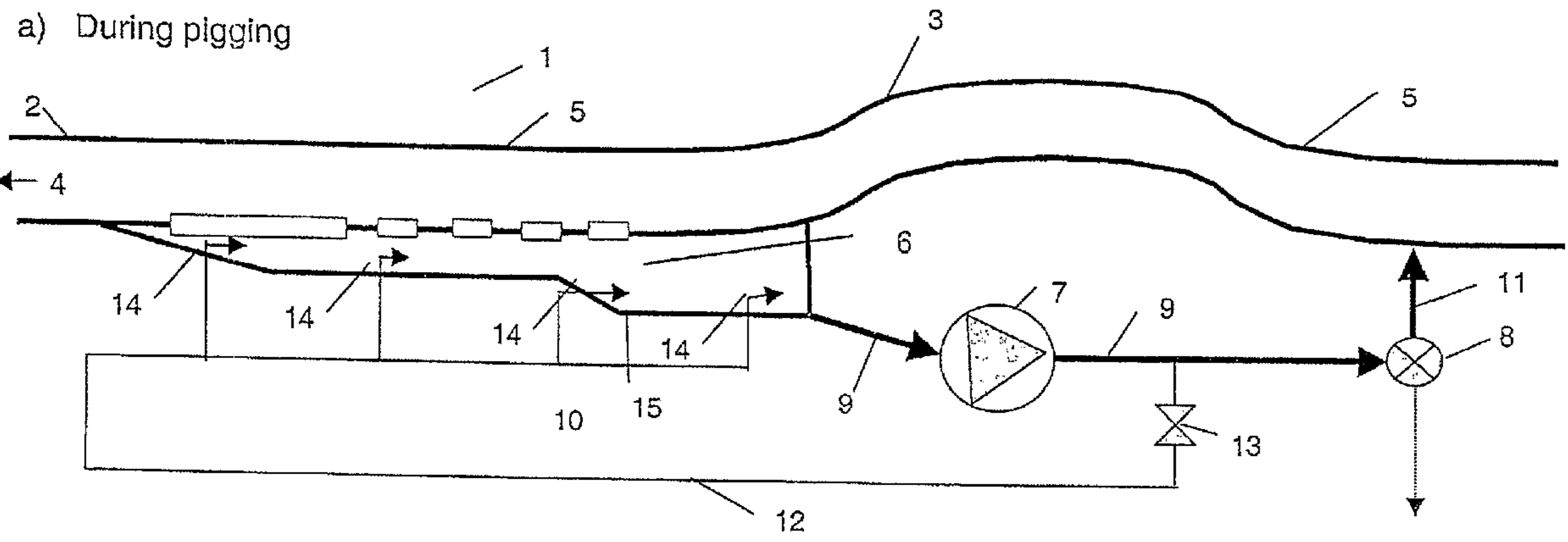

Fig 4



a) During pigging



b) During operation

