

(19) World Intellectual Property Organization  
International Bureau



(43) International Publication Date  
13 November 2008 (13.11.2008)

PCT

(10) International Publication Number  
**WO 2008/134842 A1**

(51) International Patent Classification:  
A01K 61/00 (2006.01) A01K 61/02 (2006.01)

(74) Agents: MCFADDEN, FINCHAM et al.; 225 Metcalfe Street, Suite 606, Ottawa, Ontario K2P 1P9 (CA).

(21) International Application Number:  
PCT/CA2007/000782

(81) Designated States (unless otherwise indicated, for every kind of national protection available): AE, AG, AL, AM, AT, AU, AZ, BA, BB, BG, BH, BR, BW, BY, BZ, CA, CH, CN, CO, CR, CU, CZ, DE, DK, DM, DZ, EC, EE, EG, ES, FI, GB, GD, GE, GH, GM, GT, HN, HR, HU, ID, IL, IN, IS, JP, KE, KG, KM, KN, KP, KR, KZ, LA, LC, LK, LR, LS, LT, LU, LY, MA, MD, MG, MK, MN, MW, MX, MY, MZ, NA, NG, NI, NO, NZ, OM, PG, PH, PL, PT, RO, RS, RU, SC, SD, SE, SG, SK, SL, SM, SV, SY, TJ, TM, TN, TR, TT, TZ, UA, UG, US, UZ, VC, VN, ZA, ZM, ZW.

(22) International Filing Date: 4 May 2007 (04.05.2007)

(25) Filing Language: English

(26) Publication Language: English

(71) Applicant (for all designated States except US): AQUACULTURE ENGINEERING GROUP INC. [CA/CA]; 73A Frederick Street, St. Andrews, New Brunswick E5B 1Y9 (CA).

(84) Designated States (unless otherwise indicated, for every kind of regional protection available): ARIPO (BW, GH, GM, KE, LS, MW, MZ, NA, SD, SL, SZ, TZ, UG, ZM, ZW), Eurasian (AM, AZ, BY, KG, KZ, MD, RU, TJ, TM), European (AT, BE, BG, CH, CY, CZ, DE, DK, EE, ES, FI, FR, GB, GR, HU, IE, IS, IT, LT, LU, LV, MC, MT, NL, PL, PT, RO, SE, SI, SK, TR), OAPI (BF, BJ, CF, CG, CI, CM, GA, GN, GQ, GW, ML, MR, NE, SN, TD, TG).

(72) Inventors; and

(75) Inventors/Applicants (for US only): DOBSON, Philip [CA/CA]; 449 Dawson Road, Dawson Settlement, New Brunswick, E4H 1Y8 (CA). HOAR, David [CA/CA]; 9 Moores Drive, Fredricton, New Brunswick E3C 1K9 (CA).

Published:  
— with international search report

(54) Title: IMPROVED AQUACULTURE SYSTEM

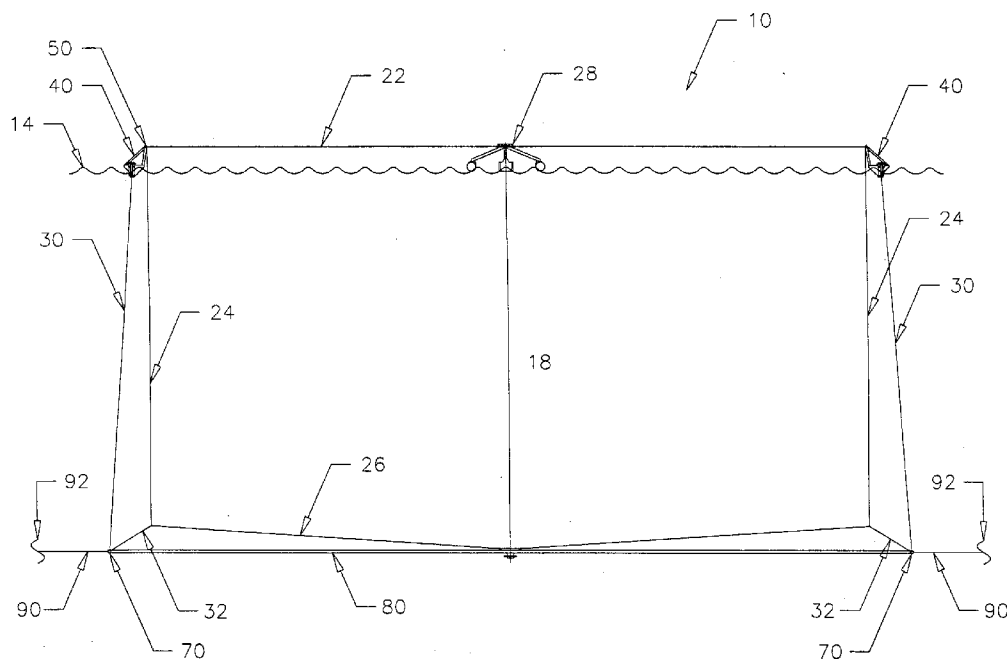

Figure 1

(57) Abstract: In the preferred embodiment there is provided an improved aquaculture system including a peripheral floatation system for suspending a containment unit in a marine environment, a peripheral weight system operatively connected to the containment unit about its lower periphery and a connection means for operatively connecting the weight system to the floatation system.

WO 2008/134842 A1

## IMPROVED AQUACULTURE SYSTEM

### FIELD OF THE INVENTION

5 The present invention is directed to an improved aquaculture system adapted for use in a marine environment, and more specifically to an improved containment unit for containing fish in a variety of conditions from protected locations to high energy wave and current conditions.

### 10 BACKGROUND OF THE INVENTION

Fish cages or pens are known in the art and are used to contain fish or other marine life found in open waters areas, which are adapted to allow for the convenient use and access to the cage for maintenance and feeding of the fish.

15 Cages typically may be portable but do not allow for easy movement and are adapted to be secured via multiple mooring systems. Other systems or cages exist which allow for cages to be placed in open sea conditions, however such systems are typically constructed as boats or huge rigid floats or floating systems with rigid frames which are often complex, expensive and require high levels of  
20 maintenance and user intervention for operation of the nets and feeding systems.

Generally speaking fish cages include some sort of floatation system to suspend the cage which is itself fastened to the ocean floor and include weight means to position the net in place. However, due to the wave action on the upper sections  
25 of the cage, problems have arisen.

The present system, for a single cage or multiple cage system, distinguishes over the earlier systems by virtue of a floatation collar which is not fastened to the ocean floor, but is directly connected to the weight means with a vertical tying  
30 or fastening system, and the way in which the weight means includes different sections which are articulated one to another and are themselves fastened to the

ocean floor allowing the floatation collar freedom of lateral movement to compensate for movement/displacement in response to ocean wave and current action.

- 5 The present invention provides for an improved cage system having simplicity and flexibility of the design, with structural flexibility is as a primary advantage which results in considerable reduction in forces acting on the system along with the ability of the present invention to adapt to the movement of waves and fish as ocean conditions change.

10

### **SUMMARY OF THE INVENTION**

In accordance with one embodiment of the present invention, there is provided an improved aquaculture system capable of being located in a marine  
15 environment for containing fish in a variety of conditions from protected locations to high energy wave and current conditions.

A primary aspect of the present invention includes the use of a floatation "collar" or system for suspending the cage, structure including weight means at the  
20 bottom of the cage, directly connected to the floatation collar to the weights through the use of a tying or connecting system.

One of the primary advantages of the present invention is that it is held entirely at the bottom of the cages 10 which is located below the wave action.

25

In accordance with one aspect of the present invention, there is provided an offshore containment system comprising: flotation means adapted to suspend an aquaculture containment unit in a marine environment; at least one containment unit including an upper and lower periphery, the unit adapted to enclose a  
30 volume of water of the marine environment and being supported by the flotation means; weight means operatively connected to the at least one containment unit

about its lower periphery; and connection means adapted to connect the weight means to the flotation means and the at least one containment unit such that the connection means maintains the containment unit in a predetermined configuration.

5

In accordance with the above aspect, the at least one containment unit includes a net system on the upper, lower and periphery and extends between both the upper and lower periphery to completely enclose a volume of water therein.

10 In accordance with any of the above aspects, the flotation means is a peripheral buoyancy system adapted to support the at least one containment unit on the surface of the water. Preferably, the peripheral buoyancy system is adapted to position the unit at or near the surface of the marine environment. Desirably, the peripheral buoyancy system includes one or more sections, the sections of which  
15 may be placed about at least a portion of the upper periphery of the containment unit.

In another aspect of the present invention, there is provided an aquaculture system comprising: a fish containment unit for enclosing a volume of water, the  
20 unit including an upper portion, lower portion and peripheral wall; flotation system operatively associated with the containment unit; weight means operatively connected to the flotation means, the weight means including at least one section; and connection means for connecting the weight means to the flotation means and to the lower portion of the containment unit.

25

The above aspects of the present invention will become evident upon reference to the attached drawings and the following detailed description of the preferred embodiment.

## BRIEF DESCRIPTION OF THE DRAWINGS

Figure 1 is a side view of an offshore marine containment system as provided for  
5 in accordance with a preferred embodiment of the present invention;

Figure 2 is a top plan view of the system as provided for in Figure 1;

Figure 3 is a top plan view system illustrated in Figure 1 a multiple cage to cage  
10 configuration;

Figure 4 is a side view of the multiple cage or configuration as illustrated in  
Figure 3;

15 Figure 5 is an enlarged view of the floatation and mooring system of the present  
invention as illustrated in Figure 1.

## DETAILED DESCRIPTION OF THE PREFERRED EMBODIMENT

20 In accordance with a preferred embodiment of the present invention, there is  
provided an improved aquaculture system or containment unit generally  
designated by reference numeral 10.

As illustrated in Figure 1, the system or cage 10 includes the use of a net or net  
25 system 20 a volume of water defining a space 18 for containing fish or other  
marine life. The net 20 includes a top or upper portion 22, side walls 24 and a  
bottom wall 26. The net or net system may be of a one piece construction or may  
be formed from multiple sections of netting. A centre net support 28 and  
connection point for the floatation system to maintain proper shape.

30

The net or net system 20 is supported at the surface of the water through the peripheral buoyancy system or floatation collar 40 to which is attached the net 20 to help support the system 10 on the body of water. The majority of the cage or containment unit 10 is immersed in a body of water and only a small portion of the top section of the containment unit 10 is above the surface 14 of the water. As illustrated, the floatation collar or peripheral buoyancy system 40 are attached to a weight ring system (discussed in greater detail hereinbelow) via fixed or flexible connecting members (such as cables, ropes or lines) generally indicated by reference numeral 30, and to the net or net system 20 by fixed or flexible members 32 to maintain the required net enclosure shape.

As illustrated, the net system 20 used in the present cage or containment system 10 may be a conventional net system 20 which encloses the top, bottom and peripheral or side of the cage and is maintained in place by the peripheral buoyancy system and peripheral weight system at the top and bottom of the structure. In a preferred embodiment, the peripheral rail 50 is used to attach at least a portion of the net via suitable means. The net system 20 is able to then be completely secured with a suitable tying or closure system in the center of the net 10 or containment system.

The containment unit 10 is supported at the surface by a peripheral buoyancy system that may be adapted to position at or near the surface 14.

The peripheral buoyancy system 40 along with the peripheral weight system 70 is shown in greater detail in Figure 5. With respect to the peripheral buoyancy system 40, the system includes a float collar identified by reference 42, which is adapted to be positioned at or near the surface of the water 14.

As illustrated, floatation system 40 includes an independent or stand alone buoyancy member(s) 42 to which are attached rails or braces 44, which extend and attach to a peripheral rail generally identified by numeral 50 positioned

above the buoyancy member 42. As contemplated, the peripheral rail 50 extends about the periphery of the containment unit 10 and provides an attachment to which the net or net system 24 may be supported near the top of the unit.

5 As illustrated in Figure 4, the system components 40 above the lower weight system 70 can react in a controlled manner to the water surface environmentally induced wave and current influences. The connection system (40 and 70) of the present invention allows reduced energy loading on exposed upper enclosure elements and reduced energy on interconnections or mooring systems.

10

Attached to the peripheral buoyancy or floatation system 40 is an adjustable cable securing means or device identified by reference numeral 60. Preferably, the cable securing means 60 includes a pulley or other similar or conventional means generally indicated by reference numeral 62 to adjust cable or flexible

15

connecting element 30 attached to the peripheral weight system in order to adjust and/or maintain the shape of the net or net system 20. Such other similar or conventional systems may include, but are not limited to, ring, loop or enclosed groove to allow the net tensioning line to slide freely and maintain tension with minimal chafing once the net system is properly shaped and

20

tensioned.

As illustrated, the floatation collar 40 is attached to the weight/grid located at or below the bottom of the cages by a system of ropes or cables 30 which give the collar 40 the ability or freedom to move in concert with the back and forth motion of the waves, thereby relieving the stress of trying to fight the waves by allowing the floatation to move back and forth with these wave motions.

25

The floatation collar 40 may be a continuous plastic collar, or may be sectional. Preferred materials include metal, plastic or wood or other conventional or suitable material known in the art. In an alternative embodiment, the weight system 70 may be in the form of articulating sections, or it may be a flexible collar

30

(for example as identified by reference numeral 72) filled with a suitable weighting substance. Desirably, the weight 72 is sufficiently rigid to hold its shape when anchoring forces are applied. As illustrated, the floatation means 40 may be single or separate individual sections, although the use of different sections encompassing the upper portion of the cage could be articulated in one embodiment.

As illustrated in Figure 5, and attached to the adjustable cable securing means 60 through cable or flexible element 30 is the peripheral weight system generally identified by reference numeral 70. The lower peripheral weight system(s) 70 are configured as enclosure system connection points allowing system components 40 above the said peripheral lower weight system to move unhindered other than to the aforesaid vertical connection devices.

As illustrated, the peripheral weight system 70 includes a weight identified by reference numeral 72 and connection points 74, 76 and 78. As illustrated, connection points 74, 76 and 78 may include apertures or other similar means adapted to serve as interconnection points to other similar enclosure systems via fixed or flexible connecting elements to maintain a consistent relationship between these enclosures. Further, connection points, for example 74, may be configured to serve as a mooring connection on single or multiple enclosure systems. As noted above, cable securing means 60 is attached to the weight system 70 via connection point 76. Connection point 78 is adapted or configured in combination with a system of cross connected cables or elements 80 to assist in maintaining the predetermined shape of the weight system.

As illustrated in Figure 5, there is provided an attachment point 74 of the weight system 70 which may be attached to additional cages or to a mooring line 90 to provide an anchor point 92 to the bottom. This anchor point 92 would allow cages 10 attached at the weight ring 70 rather than at the surface to provide a much shorter anchor and as such, have a smaller foot print on the ocean bottom.

Further, such an anchor attachment at the bottom of the weight ring will reduce stress at the top of the structure.

5 As illustrated in Figures 2, 3 and 4, the connection provisions 74 of the weight system 70 may also be used to serve as an interconnection point to other similar units 10 through suitable fixed or flexible connecting elements 96.

10 As illustrated in Figure 5, the weight system 70 in the preferred embodiment includes several individual sections connected together via flexible or hinge connections which allow for flexing in a vertical direction to accommodate forces from surface waves and current transmitted from the surface peripheral buoyancy system 40.

15 This also allows the fish, which are a part of the wave and move with it, the ability or freedom to move without being irritated or caught by the sides of the nets which now also move with the wave, water, and the fish. This makes the relative position of fish, water, and wave close to the same thereby reducing stress on the fish and the equipment.

20 The number of cages or units 10 in a grid can be one or multiple units. A single cage would be fastened at the weight ring/grid located below or at the bottom of the cage at one location (in which case it would swing), or at many places in order to have its position fixed relative to the bottom of the ocean. Cages 10 may also be strung in a line that swings or fixed in a grid pattern, which may be any  
25 pattern or rows as desired. An advantage to such an array is the saving in anchors by grouping cages, although it may be desirable to anchor cages further apart. Other patterns, such as in a circle or some other suitable pattern, will also facilitate in disease control or feeding systems.

In a further embodiment, the weight system 70 may be made up of a plurality of sections surrounding the unit 10 with adjoining or adjacent sections being interconnected to permit each section to move independently of the other.

- 5 A further advantage of the present invention is the provision of the anchor attachment (90 and 92) at the bottom of the unit 10 thereby reducing stress at the top and further reducing the site footprint.

10 It will be understood by those of skill in the art to which the present invention relates that the above described preferred embodiments are merely exemplary and are not intended to limit the scope of the present invention as claimed.

**WHAT IS CLAIMED IS:**

1. An offshore containment system comprising:
  - flotation means adapted to suspend an aquaculture containment unit in a marine environment;
  - at least one containment unit including an upper and lower periphery, said unit adapted to enclose a volume of water of said marine environment and being supported by said flotation means;
  - weight means operatively connected to said at least one containment unit about its lower periphery; and
  - connection means adapted to connect the weight means to said flotation means and said at least one containment unit such that the connection means maintains the containment unit in a predetermined configuration.
2. The containment system according to claim 1, wherein the at least one containment unit includes a net system on the upper and lower periphery and extends between both said upper and lower periphery to completely enclose a volume of water therein.
3. The containment system according to claim 1 or 2, wherein the flotation means is a peripheral buoyancy system adapted to support the at least one containment unit on the surface of the water.
4. The containment system according to claim 3, wherein the peripheral buoyancy system is adapted to position the unit at or near the surface of said marine environment.
5. The containment system according to claim 3 or 4, wherein said peripheral buoyancy system includes one or more sections which may be placed about one or more portions of the upper periphery of the at least one containment unit.

6. An aquaculture system comprising:
  - a fish containment unit for enclosing a volume of water, the unit including an upper portion, lower portion and peripheral wall;
  - flotation means operatively associated with said containment unit;
  - weight means operatively connected to the flotation means, said weight means including at least one section; and
  - connection means for connecting the weight means to said flotation means and to the lower portion of the containment unit.
  
7. The system according to claim 6, wherein the flotation means extends about at least a portion of the upper periphery of the containment unit.
  
8. The system according to claim 6, wherein the weight system includes one or more sections adapted to be connected together and spaced about the periphery of the lower portion of the containment unit.

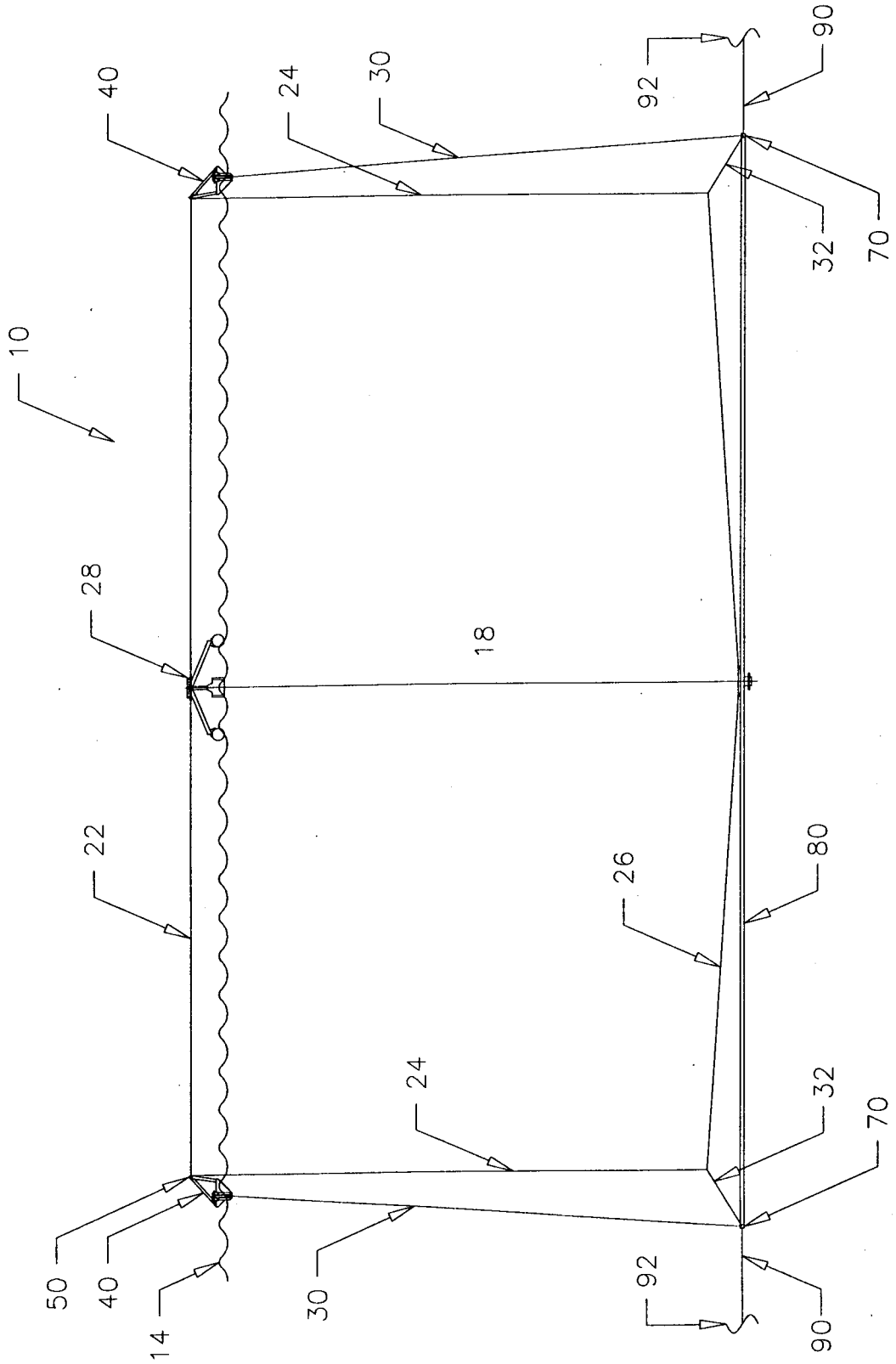

Figure 1

2/5

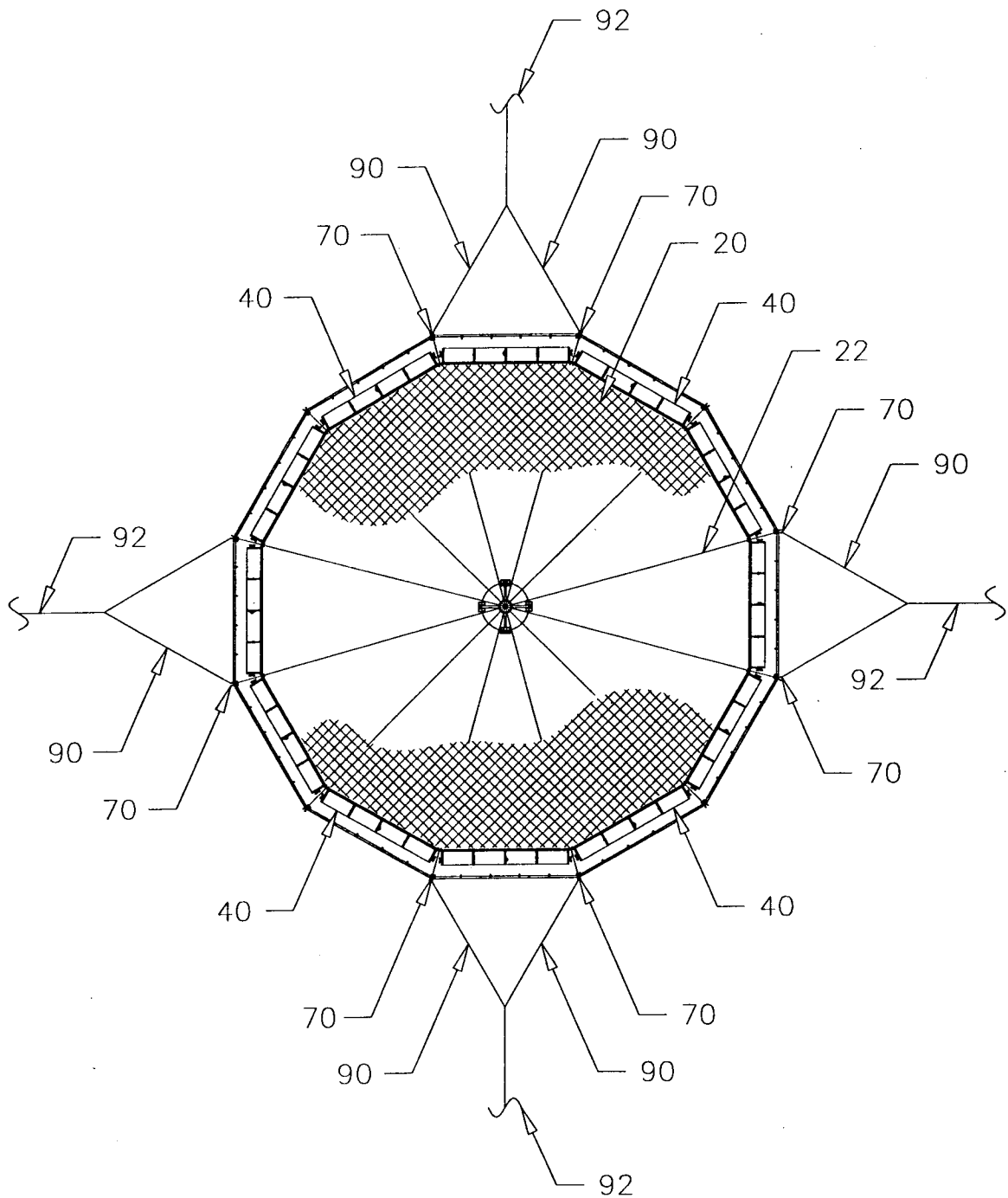

Figure 2

3/5

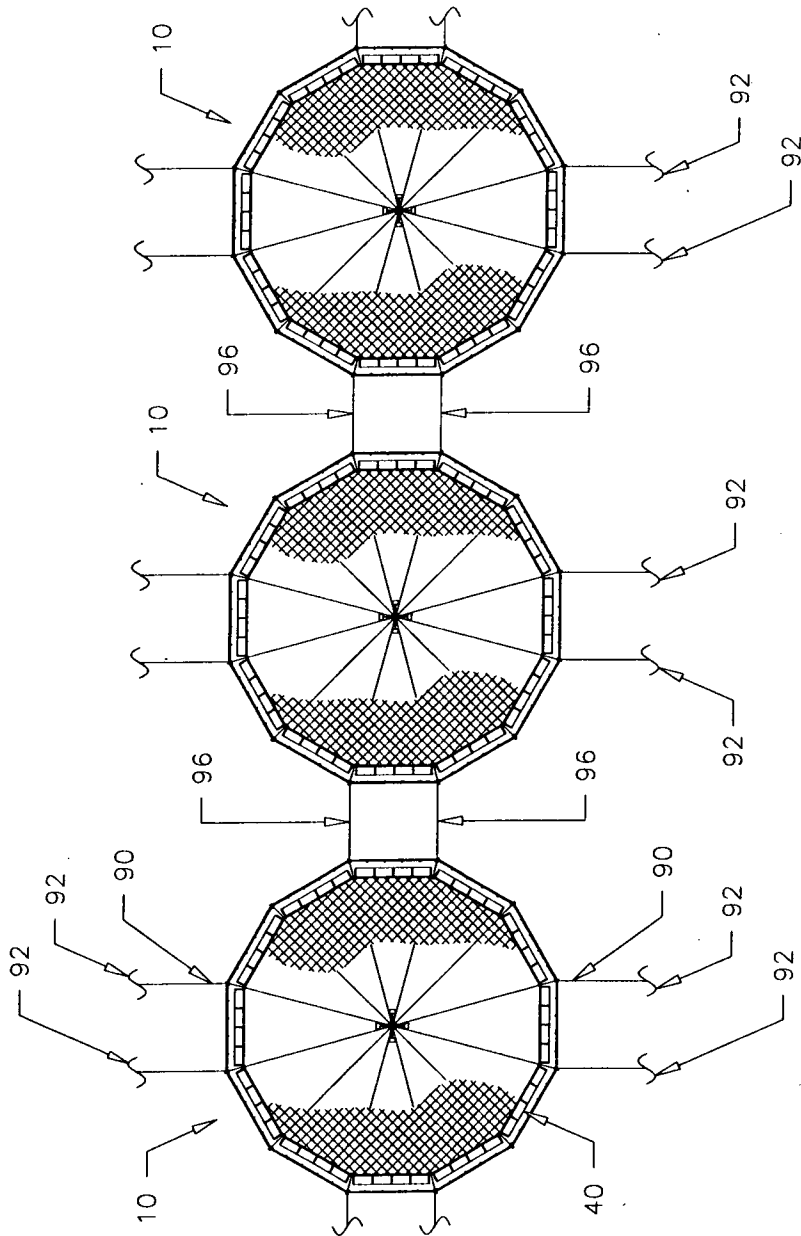

Figure 3

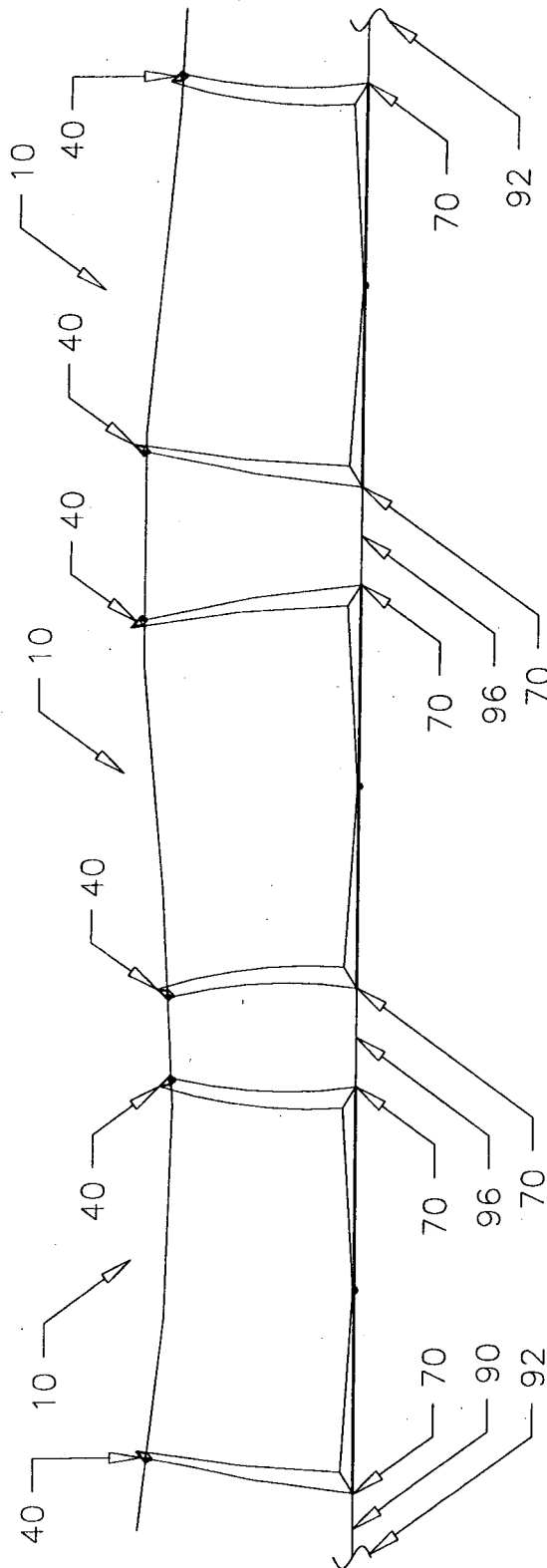
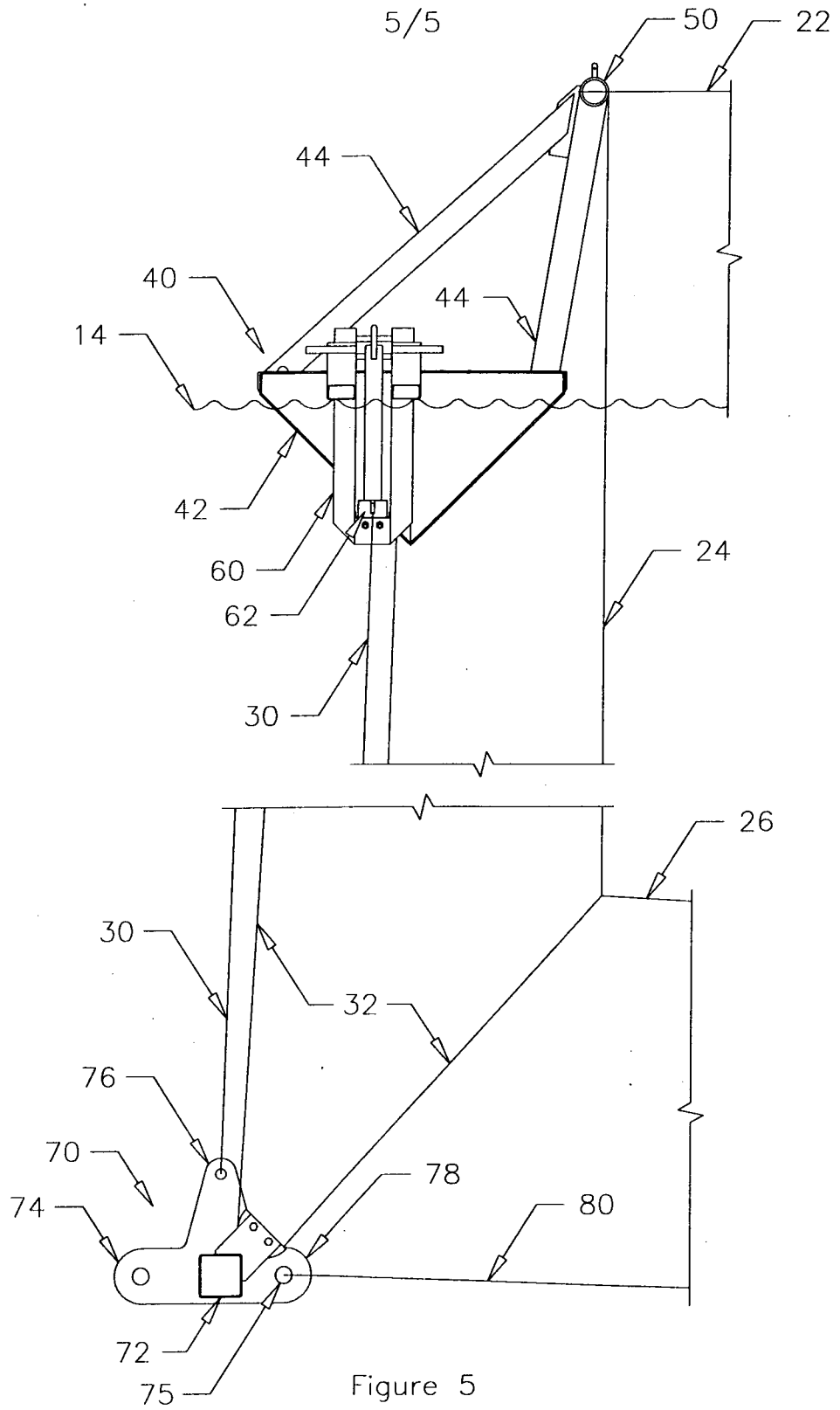

Figure 4



**INTERNATIONAL SEARCH REPORT**

International application No.  
PCT/CA2007/000782

<p>A. CLASSIFICATION OF SUBJECT MATTER  <b>IPC: A01K 61/00 (2006.01) , A01K 61/02 (2006.01)</b>                  According to International Patent Classification (IPC) or to both national classification and IPC</p>																	
<p>B. FIELDS SEARCHED</p> <p>Minimum documentation searched (classification system followed by classification symbols)                  IPC(2006.01): A01K 61/00, A01K 61/02, A01K 63/00                  ISPC: 119/223, 119/208, 119/239, 119/3</p> <p>Documentation searched other than minimum documentation to the extent that such documents are included in the fields searched</p> <p>Electronic database(s) consulted during the international search (name of database(s) and, where practicable, search terms used)                  Questel-Orbit (FamPat), USPTO, Canadian Patents Database</p>																	
<p>C. DOCUMENTS CONSIDERED TO BE RELEVANT</p> <table border="1" style="width:100%; border-collapse: collapse;"> <thead> <tr> <th style="width:10%;">Category*</th> <th style="width:60%;">Citation of document, with indication, where appropriate, of the relevant passages</th> <th style="width:30%;">Relevant to claim No.</th> </tr> </thead> <tbody> <tr> <td align="center">X ----- Y</td> <td>WO 9629860 A1 (LOVERICH, G.F. et al) 3 October 1996 (03-10-1996) * Figure 12A, Pages 12-13 *</td> <td align="center">1, 2, 6, 8  3-5, 7</td> </tr> <tr> <td align="center">Y</td> <td>WO 9831217 A1 (MIDLING, K. et al) 23 July 1998 (23-07-1998) * Entire Document *</td> <td align="center">3-5, 7</td> </tr> <tr> <td align="center">A</td> <td>WO 0049858 A1 (JORGENSEN, S. H. et al) 31 August 2000 (31-08-2000) * Entire Document *</td> <td></td> </tr> <tr> <td align="center">A</td> <td>US 5193481 A (LOVERICH, G.F. et al) 16 March 1993 (16-03-1993) * Entire Document *</td> <td></td> </tr> </tbody> </table>			Category*	Citation of document, with indication, where appropriate, of the relevant passages	Relevant to claim No.	X ----- Y	WO 9629860 A1 (LOVERICH, G.F. et al) 3 October 1996 (03-10-1996) * Figure 12A, Pages 12-13 *	1, 2, 6, 8  3-5, 7	Y	WO 9831217 A1 (MIDLING, K. et al) 23 July 1998 (23-07-1998) * Entire Document *	3-5, 7	A	WO 0049858 A1 (JORGENSEN, S. H. et al) 31 August 2000 (31-08-2000) * Entire Document *		A	US 5193481 A (LOVERICH, G.F. et al) 16 March 1993 (16-03-1993) * Entire Document *	
Category*	Citation of document, with indication, where appropriate, of the relevant passages	Relevant to claim No.															
X ----- Y	WO 9629860 A1 (LOVERICH, G.F. et al) 3 October 1996 (03-10-1996) * Figure 12A, Pages 12-13 *	1, 2, 6, 8  3-5, 7															
Y	WO 9831217 A1 (MIDLING, K. et al) 23 July 1998 (23-07-1998) * Entire Document *	3-5, 7															
A	WO 0049858 A1 (JORGENSEN, S. H. et al) 31 August 2000 (31-08-2000) * Entire Document *																
A	US 5193481 A (LOVERICH, G.F. et al) 16 March 1993 (16-03-1993) * Entire Document *																
<p><input type="checkbox"/> Further documents are listed in the continuation of Box C.      <input checked="" type="checkbox"/> See patent family annex.</p> <table border="1" style="width:100%; border-collapse: collapse;"> <tbody> <tr> <td style="width:50%;">                     * Special categories of cited documents :                      "A" document defining the general state of the art which is not considered to be of particular relevance                      "E" earlier application or patent but published on or after the international filing date                      "L" document which may throw doubts on priority claim(s) or which is cited to establish the publication date of another citation or other special reason (as specified)                      "O" document referring to an oral disclosure, use, exhibition or other means                      "P" document published prior to the international filing date but later than the priority date claimed                 </td> <td style="width:50%;">                     "T" later document published after the international filing date or priority date and not in conflict with the application but cited to understand the principle or theory underlying the invention                      "X" document of particular relevance; the claimed invention cannot be considered novel or cannot be considered to involve an inventive step when the document is taken alone                      "Y" document of particular relevance; the claimed invention cannot be considered to involve an inventive step when the document is combined with one or more other such documents, such combination being obvious to a person skilled in the art                      "&amp;" document member of the same patent family                 </td> </tr> </tbody> </table>			* Special categories of cited documents : "A" document defining the general state of the art which is not considered to be of particular relevance "E" earlier application or patent but published on or after the international filing date "L" document which may throw doubts on priority claim(s) or which is cited to establish the publication date of another citation or other special reason (as specified) "O" document referring to an oral disclosure, use, exhibition or other means "P" document published prior to the international filing date but later than the priority date claimed	"T" later document published after the international filing date or priority date and not in conflict with the application but cited to understand the principle or theory underlying the invention "X" document of particular relevance; the claimed invention cannot be considered novel or cannot be considered to involve an inventive step when the document is taken alone "Y" document of particular relevance; the claimed invention cannot be considered to involve an inventive step when the document is combined with one or more other such documents, such combination being obvious to a person skilled in the art "&" document member of the same patent family													
* Special categories of cited documents : "A" document defining the general state of the art which is not considered to be of particular relevance "E" earlier application or patent but published on or after the international filing date "L" document which may throw doubts on priority claim(s) or which is cited to establish the publication date of another citation or other special reason (as specified) "O" document referring to an oral disclosure, use, exhibition or other means "P" document published prior to the international filing date but later than the priority date claimed	"T" later document published after the international filing date or priority date and not in conflict with the application but cited to understand the principle or theory underlying the invention "X" document of particular relevance; the claimed invention cannot be considered novel or cannot be considered to involve an inventive step when the document is taken alone "Y" document of particular relevance; the claimed invention cannot be considered to involve an inventive step when the document is combined with one or more other such documents, such combination being obvious to a person skilled in the art "&" document member of the same patent family																
Date of the actual completion of the international search 23 January 2008 (23-01-2008)		Date of mailing of the international search report 04 February 2008 (04-02-2008)															
Name and mailing address of the ISA/CA Canadian Intellectual Property Office Place du Portage I, C114 - 1st Floor, Box PCT 50 Victoria Street Gatineau, Quebec K1A 0C9 Facsimile No.: 001-819-953-2476		Authorized officer <b>Yasin Bismilla 819- 934-6240</b>															

**INTERNATIONAL SEARCH REPORT**  
Information on patent family members

International application No.  
**PCT/CA2007/000782**

Patent Document Cited in Search Report	Publication Date	Patent Family Member(s)	Publication Date
WO 9629860A1	03-10-1996	AU 700230B2	24-12-1998
		AU 5321396A	16-10-1996
		CA 2216754A1	03-10-1996
		CA 2216754C	20-03-2007
		CN 1183025A	27-05-1998
		DE 69614376D1	13-09-2001
		EP 0824310A1	25-02-1998
		EP 0824310A4	01-07-1998
		EP 0824310B1	08-08-2001
		ES 2160238T3	01-11-2001
		JP 11503311T	26-03-1999
		NO 312873B1	15-07-2002
		NO 974509A	26-11-1997
		NO 974509D0	29-09-1997
		NZ 305246A	28-01-1999
US 5617813A	08-04-1997		
WO 9831217A1	23-07-1998	CA 2276739A1	23-07-1998
		EP 0961544A1	08-12-1999
		NO 303313B1	29-06-1998
		NO 970233D0	20-01-1997
WO 0049858A1	31-08-2000	AU 2700800A	14-09-2000
		CA 2362859A1	31-08-2000
		EP 1158852A1	05-12-2001
		NO 311062B1	08-10-2001
		NO 990660A	14-08-2000
NO 990660D0		NO 990660D0	12-02-1999
US 5193481A	16-03-1993	AT 130489T	15-12-1995
		CA 1321514C	24-08-1993
		DE 68924912D1	04-01-1996
		DE 68924912T2	18-04-1996
		EP 0393276A1	24-10-1990
		EP 0393276B1	22-11-1995
		ES 2080073T3	01-02-1996
		GR 3018799T3	30-04-1996
		JP 1969479C	18-09-1995
		JP 2286024A	26-11-1990
		JP 6097928B	07-12-1994
		US RE34971E	20-06-1995
		US 5007376A	16-04-1991