

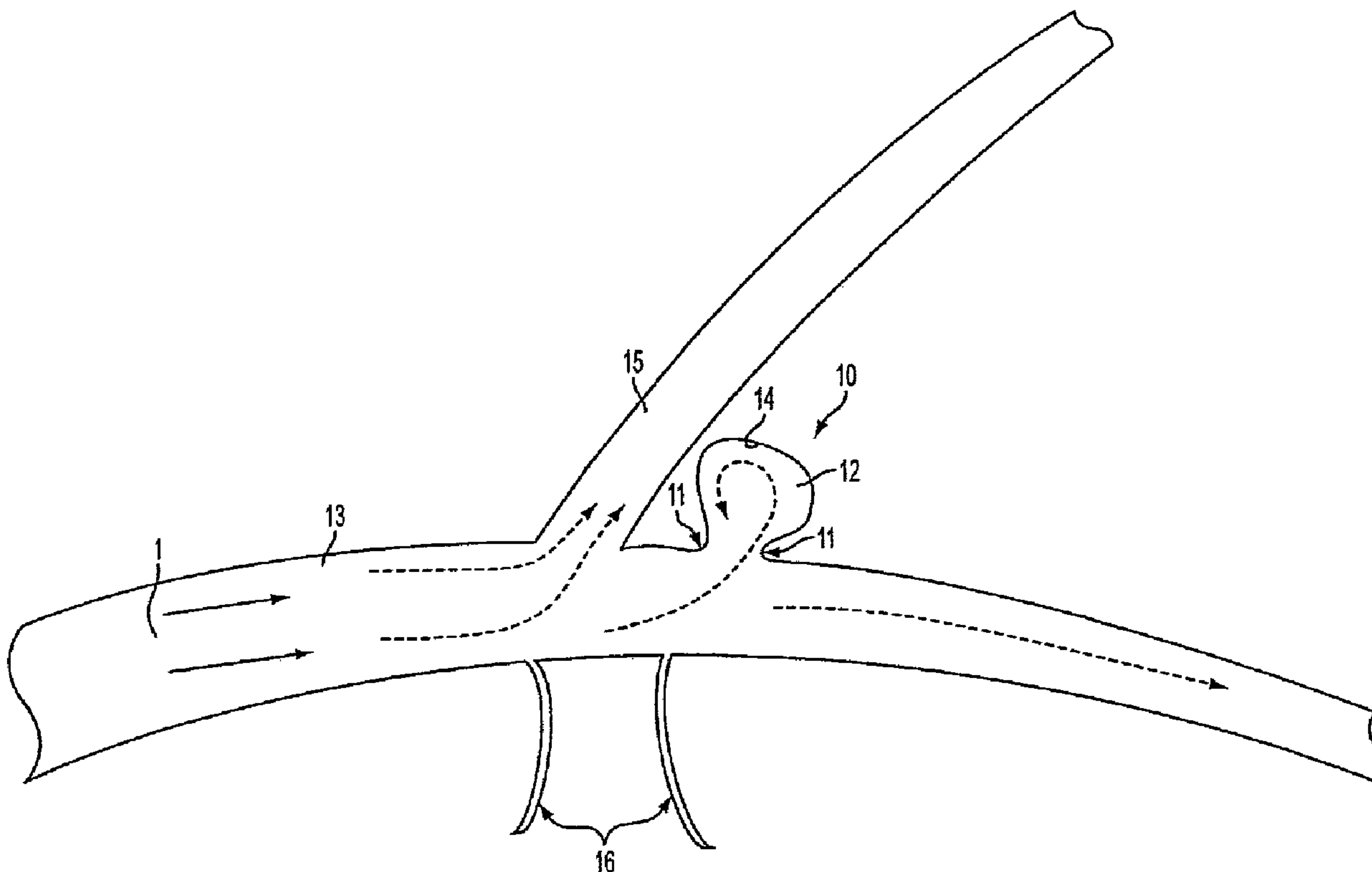

(86) Date de dépôt PCT/PCT Filing Date: 2007/05/15
 (87) Date publication PCT/PCT Publication Date: 2007/12/06
 (45) Date de délivrance/Issue Date: 2013/04/02
 (85) Entrée phase nationale/National Entry: 2008/11/13
 (86) N° demande PCT/PCT Application No.: US 2007/011551
 (87) N° publication PCT/PCT Publication No.: 2007/139689
 (30) Priorité/Priority: 2006/05/24 (US11/420,027)

(51) Cl.Int./Int.Cl. *A61F 2/88* (2006.01),
A61F 2/07 (2013.01)
 (72) Inventeurs/Inventors:
GARCIA, ADRIAN, US;
YE, TING TINA, US;
TRAN, QUANG Q., US;
BEREZ, AARON L., US
 (73) Propriétaire/Owner:
TYCO HEALTHCARE GROUP, LP, US
 (74) Agent: SMART & BIGGAR

(54) Titre : APPAREIL VASCULAIRE FLEXIBLE OCCLUSIF
 (54) Title: FLEXIBLE VASCULAR OCCLUDING DEVICE



(57) **Abrégé/Abstract:**

A vascular occluding device for modifying blood flow in a vessel, while maintaining blood flow to the surrounding tissue. The occluding device includes a flexible, easily compressible and bendable occluding device that is particularly suited for treating aneurysms in the brain. The neurovascular occluding device can be deployed using a micro-catheter. The occluding device can be formed by braiding wires in a helical fashion and can have varying lattice densities along the length of the occluding device. The occluding device could also have different lattice densities for surfaces on the same radial plane.

(12) INTERNATIONAL APPLICATION PUBLISHED UNDER THE PATENT COOPERATION TREATY (PCT)

(19) World Intellectual Property Organization
International Bureau(43) International Publication Date
6 December 2007 (06.12.2007)

PCT

(10) International Publication Number
WO 2007/139689 A3

(51) International Patent Classification:

A61F 2/06 (2006.01)

(21) International Application Number:

PCT/US2007/011551

(22) International Filing Date: 15 May 2007 (15.05.2007)

(25) Filing Language: English

(26) Publication Language: English

(30) Priority Data:

11/420,027 24 May 2006 (24.05.2006) US

(71) Applicant (for all designated States except US): **CHESTNUT MEDICAL TECHNOLOGIES, INC.** [US/US]; 173 Jefferson Drive, Menlo Park, CA 94025-1114 (US).

(72) Inventors; and

(75) Inventors/Applicants (for US only): **GARCIA, Adrian** [US/US]; 16271 Azalea Way, Los Gatos, CA 95032 (US). **YE, Ting, Tina** [US/US]; 3982 Louvre Avenue, San Jose, CA 95135 (US). **TRAN, Quang, Q.** [US/US]; 11 Channel Drive, Redwood City, CA 94065 (US). **BEREZ, Aaron, L.** [US/US]; 1485 Laurel Street, Menlo Park, CA 94025 (US).(74) Agent: **MOTTLEY, Darrell, G.**; Banner & Witcoff, Ltd., 1100 13th Street, N.w., Suite 1200, Washington, DC 20005-4051 (US).

(81) Designated States (unless otherwise indicated, for every kind of national protection available): AE, AG, AL, AM, AT, AU, AZ, BA, BB, BG, BH, BR, BW, BY, BZ, CA, CH, CN, CO, CR, CU, CZ, DE, DK, DM, DZ, EC, EE, EG, ES, FI, GB, GD, GE, GH, GM, GT, HN, HR, HU, ID, IL, IN, IS, JP, KE, KG, KM, KN, KP, KR, KZ, LA, LC, LK, LR, LS, LT, LU, LY, MA, MD, MG, MK, MN, MW, MX, MY, MZ, NA, NG, NI, NO, NZ, OM, PG, PH, PL, PT, RO, RS, RU, SC, SD, SE, SG, SK, SL, SM, SV, SY, TJ, TM, TN, TR, TT, TZ, UA, UG, US, UZ, VC, VN, ZA, ZM, ZW.

(84) Designated States (unless otherwise indicated, for every kind of regional protection available): ARIPO (BW, GH, GM, KE, LS, MW, MZ, NA, SD, SL, SZ, TZ, UG, ZM, ZW), Eurasian (AM, AZ, BY, KG, KZ, MD, RU, TJ, TM), European (AT, BE, BG, CH, CY, CZ, DE, DK, EE, ES, FI, FR, GB, GR, HU, IE, IS, IT, LT, LU, LV, MC, MT, NL, PL, PT, RO, SE, SI, SK, TR), OAPI (BF, BJ, CF, CG, CI, CM, GA, GN, GQ, GW, ML, MR, NE, SN, TD, TG).

Published:

- with international search report
- before the expiration of the time limit for amending the claims and to be republished in the event of receipt of amendments

(88) Date of publication of the international search report:

18 September 2008

(54) Title: FLEXIBLE VASCULAR OCCLUDING DEVICE

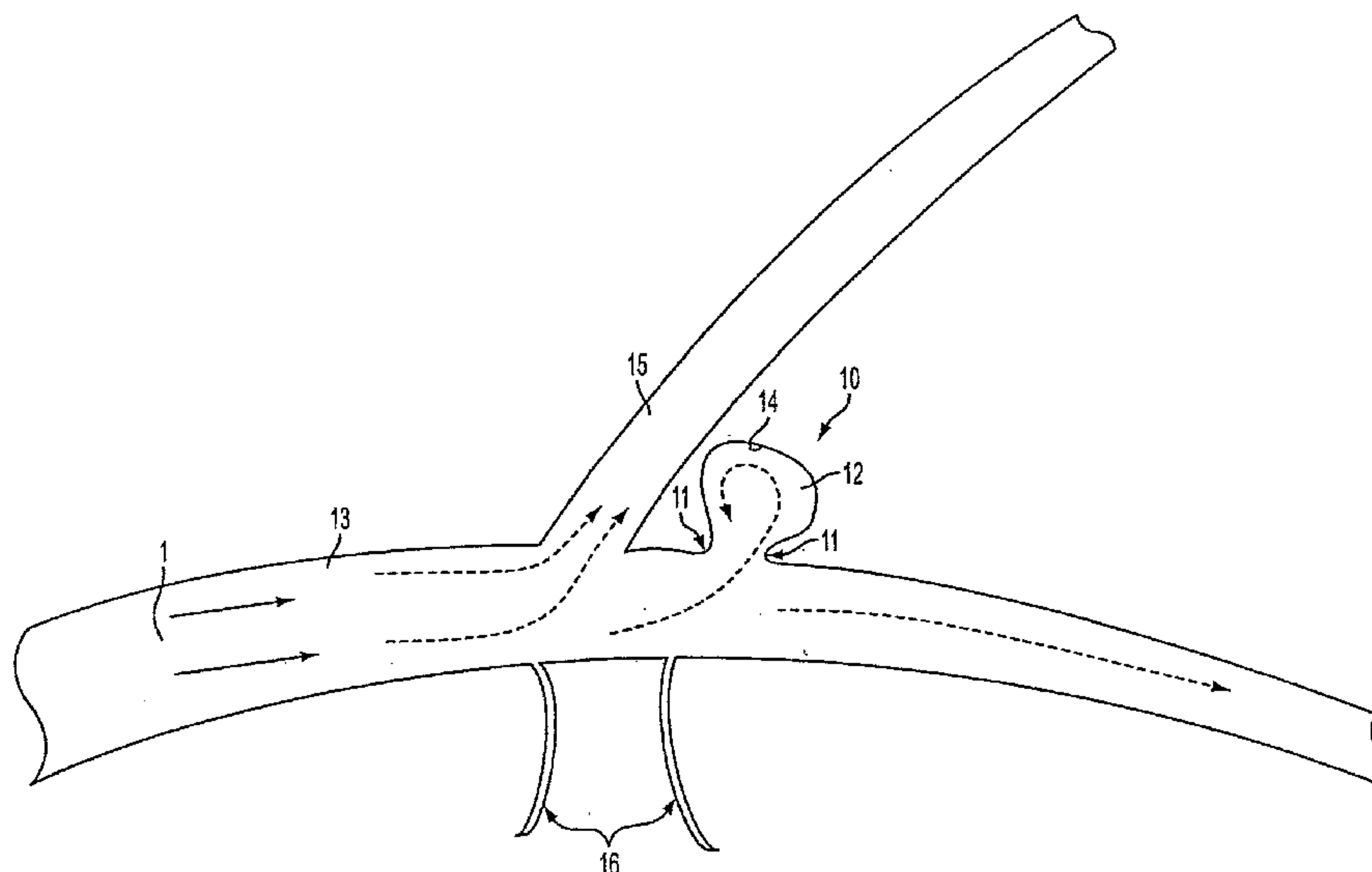

FIG. 1

(57) Abstract: A vascular occluding device for modifying blood flow in a vessel, while maintaining blood flow to the surrounding tissue. The occluding device includes a flexible, easily compressible and bendable occluding device that is particularly suited for treating aneurysms in the brain. The neurovascular occluding device can be deployed using a micro-catheter. The occluding device can be formed by braiding wires in a helical fashion and can have varying lattice densities along the length of the occluding device. The occluding device could also have different lattice densities for surfaces on the same radial plane.

WO 2007/139689 A3

FLEXIBLE VASCULAR OCCLUDING DEVICE

Field of the Invention

- [02]** The invention relates generally to an implantable device that could be used in the vasculature to treat common vascular malformations. More particularly, it relates to a flexible, biocompatible device that can be introduced into the vasculature of a patient to embolize and occlude aneurysms, particularly cerebral aneurysms.

Background of the Invention

- [03]** Walls of the vasculature, particularly arterial walls, may develop pathological dilatation called an aneurysm. Aneurysms are commonly observed as a ballooning-out of the wall of an artery. This is a result of the vessel wall being weakened by disease, injury or a congenital abnormality. Aneurysms have thin, weak walls and have a tendency to rupture and are often caused or made worse by high blood pressure. Aneurysms could be found in different parts of the body; the most common being abdominal aortic aneurysms (AAA) and the brain or cerebral aneurysms. The mere presence of an aneurysm is not always life-threatening, but they can have serious health consequences such as a stroke if one should rupture in the brain. Additionally, as is known, a ruptured aneurysm can also result in death.
- [04]** The most common type of cerebral aneurysm is called a saccular aneurysm, which is commonly found at the bifurcation of a vessel. The locus of bifurcation, the bottom of the V in the Y, could be weakened by hemodynamic forces of the blood flow. On a histological level, aneurysms are caused by damage to cells in the arterial wall. Damage is believed to be caused by shear stresses due to blood flow. Shear stress generates heat that breaks down the cells. Such hemodynamic stresses at the vessel wall, possibly in conjunction with intrinsic abnormalities of the vessel wall, have been

considered to be the underlying cause for the origin, growth and rupture of these saccular aneurysms of the cerebral arteries (Lieber and Gounis, *The Physics of Endoluminal stenting in the Treatment of Cerebrovascular Aneurysms*, *Neurol Res* 2002; 24: S32-S42). In histological studies, damaged intimal cells are elongated compared to round healthy cells. Shear stress can vary greatly at different phases of the cardiac cycle, locations in the arterial wall and among different individuals as a function of geometry of the artery and the viscosity, density and velocity of the blood. Once an aneurysm is formed, fluctuations in blood flow within the aneurysm are of critical importance because they can induce vibrations of the aneurysm wall that contribute to progression and eventual rupture. For a more detailed description of the above concepts see, for example, Steiger, *Pathophysiology of Development and Rupture of Cerebral Aneurysms*, *Acta Neurochir Suppl* 1990; 48: 1-57; Fergusson, *Physical Factors in the Initiation, Growth and Rupture of Human Intracranial Saccular Aneurysms*, *J Neurosurg* 1972; 37: 666-677.

- [05] Aneurysms are generally treated by excluding the weakened part of the vessel from the arterial circulation. For treating a cerebral aneurysm, such reinforcement is done in many ways: (i) surgical clipping, where a metal clip is secured around the base of the aneurysm; (ii) packing the aneurysm with microcoils, which are small, flexible wire coils; (iii) using embolic materials to "fill" an aneurysm; (iv) using detachable balloons or coils to occlude the parent vessel that supplies the aneurysm; and (v) endovascular stenting. For a general discussion and review of these different methods see Qureshi, *Endovascular Treatment of Cerebrovascular Diseases and Intracranial Neoplasms*, *Lancet*. 2004 Mar 6;363 (9411):804-13; Brilstra et al. *Treatment of Intracranial Aneurysms by Embolization with Coils: A Systematic Review*, *Stroke* 1999; 30: 470-476.
- [06] As minimally invasive interventional techniques gain more prominence, micro-catheter based approaches for treating neurovascular aneurysms are becoming more prevalent. Micro-catheters, whether flow-directed or wire-directed, are used for dispensing embolic materials, microcoils or other structures (e.g., stents) for embolization of the aneurysm. A microcoil can be passed through a micro-catheter and deployed in an aneurysm using mechanical or chemical detachment mechanisms, or be deployed into the parent vessel to permanently occlude it and thus block flow

into the aneurysm. Alternatively, a stent could be tracked through the neurovasculature to the desired location. Article by Pereira, History of Endovascular Aneurysms Occlusion in Management of Cerebral Aneurysms; Eds: Le Roux et al., 2004, pp: 11-26 provides an excellent background on the history of aneurysm detection and treatment alternatives.

- [07]** As noted in many of the articles mentioned above, and based on the origin, formation and rupture of the cerebral aneurysm, it is obvious that the goal of aneurysmal therapy is to reduce the risk of rupture of the aneurysm and thus the consequences of sub-arachnoid hemorrhage. It should also be noted that while preventing blood from flowing into the aneurysm is highly desirable, so that the weakened wall of the aneurysm doesn't rupture, it may also be vital that blood flow to the surrounding structures is not limited by the method used to obstruct blood flow to the aneurysm. Conventional stents developed for treating other vascular abnormalities in the body are ill suited for embolizing cerebral aneurysms. This could lead to all the usual complications when high oxygen consumers, such as brain tissue, are deprived of the needed blood flow.
- [08]** There are many shortcomings with the existing approaches for treating neurovascular aneurysms. The vessels of the neurovasculature are the most tortuous in the body; certainly more tortuous than the vessels of the coronary circulation. Hence, it is a challenge for the surgeon to navigate the neurovasculature using stiff coronary stents that are sometimes used in the neurovasculature for treating aneurysms. The bending force of a prosthesis indicates the maneuverability of the prosthesis through the vasculature; a lower bending force would imply that the prosthesis is more easily navigated through the vasculature compared to one with a higher bending force. Bending force for a typical coronary stent is 0.05 lb-in (force to bend 0.5 inches cantilever to 90 degree). Hence, it will be useful to have neural prosthesis that is more flexible than existing stents.
- [09]** Existing stent structures, whether used in coronary vessels or in the neurovasculature (microcoils) are usually straight, often laser cut from a straight tubing or braiding with stiff metallic materials. However, most of the blood vessels are curved. Hence, current stent structures and microcoils impart significant stress on the vessel walls as they try to straighten a curved vessel wall. For a weakened vessel wall, particularly

where there is a propensity for an aneurysm formation, this could have disastrous consequences.

- [10] As noted earlier, the hemodynamic stress placed on the blood vessels, particularly at the point of bifurcation, leads to weakening of the vessel walls. The most significant source of such stress is the sudden change in direction of the blood flow. Hence, if one were to minimize the sudden change in direction of blood flow, particularly at the location of vessel weakness, it would be beneficial.
- [11] Existing approaches to occluding aneurysms could lead to another set of problems. Methods that merely occlude the aneurysm by packing or filling it with embolic material (coils or liquid polymers) do not address the fundamental flow abnormalities that contribute to the formation of aneurysm.
- [12] Currently, many different stent structures and stent deployment methods exist. A stent structure could be expanded after being placed intraluminally on a balloon catheter. Alternatively, self-expanding stems could be inserted in a compressed state and expanded upon deployment. All the stents need to have the radial rigidity to maintain patency of the lumen and simultaneously have the longitudinal flexibility to facilitate navigating the tortuous path of the vasculature. For balloon expandable stents, the stent is mounted on a balloon at the distal end of a catheter, the catheter is advanced to the desired location and the balloon is inflated to expand the stent into a permanent expanded condition. The balloon is then deflated and the catheter withdrawn leaving the expanded stent to maintain vessel patency. Because of the potentially lethal consequences of dissecting or rupturing an intracerebral vessel, the use of balloon expandable stents in the brain is fraught with problems. Proper deployment of a balloon expandable stent requires slight over expanding of the balloon mounted stent to embed the stent in the vessel wall and the margin of error is small. Balloon expandable stents are also poorly suited to adapt to the natural tapering of cerebral vessels which taper proximally to distally. If a stent is placed from a parent vessel into a smaller branch vessel the change in diameter between the vessels makes it difficult to safely deploy a balloon expandable stent. A self-expanding stent, where the compressed or collapsed stent is held by an outer restraining sheath over the compressed stent to maintain the compressed state until deployment. At the time of deployment, the restraining outer sheath is retracted to uncover the compressed stent,

which then expands to keep the vessel open. Additionally, the catheters employed for delivering such prosthesis are micro-catheters with outer diameter of 0.65 mm to 1.3 mm compared to the larger catheters that are used for delivering the large coronary stents to the coronaries.

- [13] US Patent No. 6,669,719 (Wallace et al.) describes a stent and a stent catheter for intra-cranial use. A rolled sheet stent is releasably mounted on the distal tip of a catheter. Upon the rolled sheet being positioned at the aneurysm, the stent is released. This results in immediate and complete isolation of an aneurysm and surrounding side branches of the circulatory system and redirecting blood flow away from the aneurysm. A significant drawback of such a system is that the surrounding side branches, along with the target aneurysm, are deprived of the needed blood flow after the stent has been deployed.
- [14] US Patent No. 6,605,110 (Harrison) describes a self-expanding stent for delivery through a tortuous anatomy or for conforming the stent to a curved vessel. This patent describes a stent structure with radially expandable cylindrical elements arranged in parallel to each other and interspersed between these elements and connecting two adjacent cylindrical elements are struts that are bendable. While this structure could provide the necessary flexibility and bendability of the stent for certain applications, it is expensive and complex to manufacture.
- [15] US Patent No. 6,572,646 (Boylan) discloses a stent made up of a super-elastic alloy, such as Ni-Ti alloy (Nitinol), with a low temperature phase that induces a first shape to the stent and a high temperature phase that induces a second shape to the stent with a bend along the length. US Patent No. 6,689,162 (Thompson) discloses a braided prosthesis that uses strands of metal, for providing strength, and compliant textile strands. US Patent No. 6,656,218 (Denardo et al.) describes an intravascular flow modifier that allows microcoil introduction even after placing the modifier.

Summary of the Invention

- [16]** An aspect of the present invention provides a highly flexible implantable occluding device that can easily navigate the tortuous vessels of the neurovasculature. Additionally, the occluding device can easily conform to the shape of the tortuous vessels of the vasculature. Furthermore, the occluding device can direct the blood flow within a vessel away from an aneurysm; additionally such an occluding device allows adequate blood flow to be provided to adjacent structures such that those structures, whether they are branch vessels or oxygen demanding tissues, are not deprived of the necessary blood flow.
- [17]** In some embodiments, the occluding device is also capable of altering blood flow to the aneurysm, yet maintaining the desired blood flow to the surrounding tissue and within the vessel. In this instance, some blood is still allowed to reach the aneurysm, but not enough to create a laminar flow within the aneurysm that would cause injury to its thinned walls. Instead, the flow would be intermittent, thereby providing sufficient time for blood clotting or filler material curing within the aneurysm.
- [18]** The occluding device may be flexible enough to closely approximate the native vasculature and conform to the natural tortuous path of the native blood vessels. In some embodiments, the occluding device may flex and bend, thereby assuming the shape of a vasculature within the brain. These characteristics are for a neurovascular occluding device than compared to a coronary stent, as the vasculature in the brain is smaller and more tortuous.
- [19]** In general terms, aspects of the present invention relate to methods and devices for treating aneurysms. In an aspect, a method of treating an aneurysm with a neck comprises deploying a vascular occluding device in the lumen of a vessel at the location of the aneurysm, whereby the blood flow is redirected away from the neck of the aneurysm. The induced stagnation of the blood in the lumen of the aneurysm would create embolization in the aneurysm. The occluding device spans the width of

the stem of the aneurysm such that it obstructs or minimizes the blood flow to the aneurysm. The occluding device is very flexible in both its material and its arrangement. As a result, the occluding device can be easily navigated through the tortuous blood vessels, particularly those in the brain. Because the occluding device is flexible, very little force is required to deflect the occluding device to navigate through the vessels of the neurovasculature, which is of significance to the operating surgeon.

- [20] In some embodiments, the occluding device may have an asymmetrical braid pattern with a higher concentration of braid strands or a different size of braid strands on the surface facing the neck of the aneurysm compared to the surface radially opposite to it. In one embodiment, the surface facing the aneurysm is almost impermeable and the diametrically opposed surface is highly permeable. Such a construction may direct blood flow away from the aneurysm, but maintain blood flow to the side branches of the main vessel in which the occluding device is deployed.
- [21] In another embodiment, the occluding device has an asymmetrical braid count along the longitudinal axis of the occluding device. This provides the occluding device with a natural tendency to curve, and hence conform to the curved blood vessel. This reduces the stress exerted by the occluding device on the vessel wall and thus, the chances of aneurysm rupture. Additionally, because the occluding device is naturally curved, this eliminates the need for the tip of the micro-catheter to be curved. Now, when the curved occluding device is loaded on to the tip of the micro-catheter, the tip takes the curved shape of the occluding device. The occluding device could be pre-mounted inside the micro-catheter and can be delivered using a plunger, which will push the occluding device out of the micro-catheter when desired. The occluding device could be placed inside the micro-catheter in a compressed state. Upon exiting the micro-catheter, it could expand to the size of the available lumen and maintain patency of the lumen and allow blood flow through the lumen. The occluding device could have a lattice structure and the size of the openings in the lattice could vary along the length of the occluding device. The size of the lattice openings can be controlled by the braid count used to construct the lattice.

[21a] According to one aspect of the invention, there is disclosed a system, for treatment of an aneurysm, comprising: a tubular-shaped device for positioning by a user within a blood vessel for treatment of an aneurysm, the device including a plurality of strands of helically-wound material in a lattice structure, wherein the device is self-expandable to a first expanded tubular configuration, such that the device engages an inner surface of a blood vessel with a surface of the device being apposed to the vessel surface, the first expanded tubular configuration having a first porosity in a first portion and in a second portion along a length of the tubular-shaped device, the second portion being adjustable, after engagement of the device with the vessel surface, along a length of the second portion to change the device into a second expanded tubular configuration based on an input by the user while the device remains engaged with the vessel surface, such that the second portion acquires a second porosity, different from the first porosity, while the first portion maintains the first porosity; an elongate member configured to be positioned in the blood vessel, engage the device, and change the device from the first configuration to the second configuration based on the input; wherein the input comprises movement, by the user, of the elongate member in contact with the device.

[22] According to another aspect of the invention, the occluding device can be used to remodel an aneurysm within the vessel by, for example, neck reconstruction or balloon remodeling. The occluding device can be used to form a barrier that retains occlusion material within the aneurysm so that introduced material will not escape from within the aneurysm due to the lattice density of the occluding device in the area of the aneurysm.

[23] In another aspect of the invention, a device for occluding an aneurysm is disclosed. The device is a tubular with a plurality of perforations distributed on the wall of the member. The device is placed at the base of the aneurysm covering the neck of the

aneurysm such that the normal flow to the body of the aneurysm is disrupted and thereby generating thrombus and ultimately occlusion of the aneurysm.

- [24] In yet another aspect of this invention, the device is a braided tubular member. The braided strands are ribbons with rectangular cross section, wires with a circular cross section or polymeric strands.
- [25] In another embodiment, a device with a braided structure is made in order to conform to a curved vessel in the body, where the density of the braid provides enough rigidity and radial strength. Additionally, the device can be compressed using a force less than 10 grams. This enables the device to be compliant with the artery as the arterial wall is pulsating. Also, the device is capable of bending upon applying a force of less than 5 gram/cm.
- [26] In another aspect, the device may include an occluding device having a first lattice density in one portion and a second lattice density in a second portion, the first and second lattice densities being different. In another example, the first lattice density and/or the second lattice density may be adjusted. For example, an input motion may determine the first and/or lattice density.
- [27] Other aspects of the invention include methods corresponding to the devices and systems described herein.

Brief Description of the Drawings

- [28] The invention has other advantages and features which will be more readily apparent from the following detailed description of the invention and the appended claims, when taken in conjunction with the accompanying drawings, in which:
- [29] FIG. 1 is an illustration of an aneurysm, branch vessels and blood flow to the aneurysm.
- [30] FIGS. 2A and 2B illustrate one embodiment of an occluding device to treat aneurysms.
- [31] FIG. 3 is an illustration of the embodiment shown in FIG. 2 in a compressed state inside a micro-catheter.

- [32] FIG. 4A is another embodiment of an occluding device for treating aneurysms.
- [33] FIGS. 4B and 4C illustrate cross sections of portions of ribbons that can be used to form the occluding device of FIG. 4A.
- [34] FIG. 5 shows the occluding device in a compressed state inside a micro-catheter being advanced out of the micro-catheter using a plunger.
- [35] FIG. 6 shows the compressed occluding device shown in FIG. 5 deployed outside the micro-catheter and is in an expanded state.
- [36] FIG. 7 shows the deployed occluding device inside the lumen of a vessel spanning the neck of the aneurysm, a bifurcation and branch vessels.
- [37] FIG. 8 is a schematic showing the occluding device located in the lumen of a vessel and the change in the direction of the blood flow.
- [38] FIG. 9 shows the effect of a bending force on a conventional stent compared to the occluding device of the present invention.
- [39] FIG. 10 demonstrates the flexibility of the current invention, compared to a traditional stent, by the extent of the deformation for an applied force.
- [40] FIG. 11 shows the non-uniform density of the braid that provides the desired curved occluding device.
- [41] FIG. 12 illustrates the difference in lattice density or porosity due to the non-uniform density of the braiding of the occluding device.
- [42] FIG. 13 shows the varying lattice density occluding device covering the neck of an aneurysm.
- [43] FIGS. 14 and 15 show an embodiment of the vascular occluding device where the lattice density is asymmetrical about the longitudinal axis near the aneurysm neck.
- [44] FIG. 16 illustrates a bifurcated occluding device according to an embodiment of the present invention in which two occluding devices of lesser densities are combined to form a single bifurcated device.

- [45] FIG. 17 illustrates an example of a lattice density adjusting implement for adjusting lattice density in an occluding device.
- [46] FIG. 18 shows an example of a deployed occluding device inside the lumen of a vessel spanning the neck of aneurysms, a bifurcation and branch vessels.

Detailed Description Of The Preferred Embodiments

- [47] The devices shown in the accompanying drawings are intended for treating aneurysms. They are generally deployed, using micro-catheters, at the location of a cerebral aneurysm that is intended to be treated. One such system is disclosed in copending U.S. Patent Publication titled "System and Method for Delivering and Deploying an Occluding Device Within a Vessel", U.S. Serial Number 2006/0271149, filed on May 25, 2005. The embodiments of the endovascular occluding device according to aspects of the present invention is useful for treating cerebral aneurysms that are commonly treated using surgical clips, microcoils or other embolic devices.
- [48] FIG. 1 illustrates a typical cerebral aneurysm 10 in the brain. A neck 11 of the aneurysm 10 can typically define an opening of between about 2 to 25 mm. As is understood, the neck 11 connects the vessel 13 to the lumen 12 of the aneurysm 10. As can be seen in FIG. 1, the blood flow 1 within the vessel 13 is channeled through the lumen 12 and into the aneurysm. In response to the constant blood flow into the aneurysm, the wall 14 of lumen 12 continues to distend and presents a significant risk of rupturing. When the blood within the aneurysm 10 causes pressure against the wall 14 that exceeds the wall strength, the aneurysm ruptures. The present invention could prevent such ruptures. Also shown in FIG. 1 are the bifurcation 15 and the side branches 16.
- [49] FIG. 2 illustrates one embodiment of a vascular occluding device 20 in accordance with an aspect of the present invention. In the illustrated embodiment, the occluding device 20 has a substantially tubular structure 22 defined by an outer surface 21, an inner surface 24 and a thin wall that extends between the surfaces 21, 24. A plurality of openings 23 extend between the surfaces 21, 24 and allow for fluid flow from the interior of the occluding device 20 to the wall of the vessel. Occluding device 20 is radially compressible and longitudinally adjustable.

- [50] FIG. 3 shows a micro-catheter 25 and the occluding device 20 inside the micro-catheter 25 in a compressed state prior to being released within the vasculature of the patient.
- [51] FIG. 4 illustrates another embodiment of the occluding device 30 having two or more strands of material(s) 31, 32 wound in a helical fashion. The braiding of such material in this fashion results in a lattice structure 33. As can be understood, the dimension of the lattice 33 and the formed interstices 34 is determined, at least in part, by the thickness of the strand materials, the number of strands and the number of helices per unit length of the occluding device 30.
- [52] The occluding device 30 is radially compressible and radially expandable without the need for supplemental radially expanding force, such as an inflatable balloon. The occluding device 30 is constructed by winding the two strands (31, 32 in opposite directions. In an embodiment, the strands 31, 32 are in the shape of rectangular ribbon (See Figure 4C). The ribbons can be formed of known flexible materials including shape memory materials, such as Nitinol, platinum and stainless steel.
- [53] The ribbon used as the braiding material for the strands 31, 32 can include a rectangular cross section 35 (Figure 4C). As shown in Figures 4C and 7, the surface 36 that engages an inner surface of the vessel has a longer dimension (width) when compared to the wall 38 that extends between the surfaces 36, 37 (thickness). A ribbon with rectangular cross section has a higher recovery (expansive) force for the same wall thickness when compared to a wire with a circular (round) cross section. Additionally, a flat ribbon allows for more compact compression of the occluding device 20 and causes less trauma to the vascular wall when deployed because it distributes the radial expansion forces over a greater surface area. Similarly, flat ribbons form a more flexible device for a given lattice density because their surface area (width) is greater for a given thickness in comparison to round wire devices.
- [54] While the illustrated embodiment discloses a ribbon having a rectangular cross section in which the length is greater than its thickness, the ribbon for an alternative embodiment of the disclosed occluding devices may include a square cross section. In another alternative embodiment, a first portion of the ribbon may include a first form of rectangular cross section and a second portion 39 of the ribbon (Figure 4B)

may include a round, elliptical, oval or alternative form of rectangular cross section. For example, end sections of the ribbons may have substantially circular or oval cross section and the middle section of the ribbons could have a rectangular cross section.

- [55] In an alternative embodiment as described above, the occluding device 30 can be formed by winding more than two strands of ribbon. In an embodiment, the occluding device 30 could include as many as sixteen strands of ribbon. In another embodiment, the occluding device 30 can include as many as 32 strands of ribbon, as many as 48 strands of ribbon, as many as 60 strands of ribbon, as many as 80 strands of ribbon, as many as 100 strands of ribbon, as many as 150 strands of ribbon or greater than 150 strands of ribbon, for example. By using standard techniques employed in making radially expanding stents, one can create an occluding device 30 with interstices 34 that are larger than the thickness of the ribbon or diameter of the wire. The ribbons can have different widths. In such an embodiment, the different ribbon(s) can have different width(s) to provide structure support to the occluding device 30 and the vessel wall. The ribbons according to the disclosed embodiments can also be formed of different materials. For example, one or more of the ribbons can be formed of a biocompatible metal material, such as those disclosed herein, and one or more of the ribbons can be formed of a biocompatible polymer.
- [56] FIG. 5 shows the intravascular occluding device 30 in a radially compressed state located inside the micro-catheter 25. In one embodiment, the occluding device 30 could be physically attached to the catheter tip. This could be accomplished by constraining the occluding device 30 in the distal segment of the micro-catheter. The micro-catheter 25 is slowly advanced over a guidewire (not shown) by a plunger 50 and when the tip of the micro-catheter 25 reaches the aneurysm, the occluding device is released from the tip. The occluding device 30 expands to the size of the vessel and the surface of the occluding device 30 is now apposed to the vessel wall 15 as shown in FIG. 6. Instruments and methods for delivering and deploying the occluding device 30 are disclosed in the above-referenced copending application.
- [57] With reference to FIG. 7, the occluding device 30 is deployed inside the lumen of a cerebral vessel 13 with an aneurysm 10. During its deployment, the proximal end 43 of the occluding device 30 is securely positioned against the lumen wall of the vessel 13 before the bifurcation 15 and the distal end 45 of the occluding device 30 is

securely positioned against the lumen wall of the vessel 13 beyond the neck 11 of aneurysm 10. After the occluding device 30 is properly positioned at the desired location within the vessel 13 (for example, see FIG. 7), flow inside the lumen of aneurysm 10 is significantly minimized while the axial flow within the vessel 13 is not significantly compromised, in part due to the minimal thickness of the walls 38.

- [58] The flow into the aneurysm 10 will be controlled by the lattice density of the ribbons and the resulting surface coverage. Areas having greater lattice densities will have reduced radial (lateral) flow. Conversely, areas of lesser lattice densities will allow significant radial flow through the occluding device 30. As discussed below, the occluding device 30 can have longitudinally extending (lateral) areas of different densities. In each of these areas, their circumferential densities can be constant or vary. This provides different levels of flow through adjacent lateral areas. The location within a vessel of the areas with greater densities can be identified radiographically so that the relative position of the occluding device 30 to the aneurysm 10 and any vascular branches 15, 16 can be determined. The occluding device 30 can also include radiopaque markers.
- [59] The reduction of blood flow within the aneurysm 10 results in a reduction in force against the wall 14 and a corresponding reduction in the risk of vascular rupturing. When the force and volume of blood entering the aneurysm 10 is reduced by the occluding device, the laminar flow into the aneurysm 10 is stopped and the blood within the aneurysm begins to stagnate. Stagnation of blood, as opposed to continuous flow through the lumen 12 of the aneurysm 10, results in thrombosis in the aneurysm 10. This also protects the aneurysm from rupturing. Additionally, due to the density of the portion of the occluding device 30 at the bifurcation 15, the openings (interstices) 34 in the occluding device 30 allow blood flow to continue to the bifurcation 15 and the side branches 16 of the vessel. If the bifurcation 15 is downstream of the aneurysm, as shown in FIG. 8, the presence of the occluding device 30 still channels the blood away from the aneurysm 10 and into the bifurcation 15.
- [60] The occluding devices described herein have the flexibility necessary to conform to the curvature of the vasculature. This is in contrast to coronary stents that cause the vasculature to conform essentially to their shape. The ability to conform to the shape

of the vasculature is more significant for neurovascular occluding devices than coronary stents, as the vasculature in the brain is smaller and more tortuous. Tables 5 and 6 demonstrate these characteristics of the claimed neurovascular occluding device. To demonstrate that the disclosed occluding devices exhibit very desirable bending characteristics, the following experiment was performed. The occluding device made by the inventors was set on a support surface 90 as shown in FIG. 9. About 0.5 inches of the occluding device 30 was left unsupported. Then, a measured amount of force was applied to the unsupported tip until the occluding device was deflected by 90 degrees from the starting point. A similar length of a commercially available coronary stent was subjected to the same bending moment. The results are shown in Table 5. Similar to the reduced compressive force, the occluding device of the present invention required an order of magnitude lower bending moment (0.005 lb-in compared to 0.05 lb-in for a coronary stent).

Table 5: Bending Force Required to Bend a 0.5 " Cantilever Made by the Occlusion Device

| | | |
|----------------|------------------------------|-------------|
| Coronary stent | commercially available stent | 0.05 lb-in |
| Neurovascular | Occluding Device (30) | 0.005 lb-in |

[61] The occluding devices according to the present invention also provides enhanced compressibility (i.e., for a given force how much compression could be achieved or to achieve a desired compression how much force should be exerted) compared to coronary stents. An intravascular device that is not highly compressible is going to exert more force on the vessel wall compared to a highly compressible device. This is of significant clinical impact in the cerebral vasculature as it is detrimental to have an intravascular device that has low compressibility.

Table 6: Compressive Force Required to Compress the Occluding device to 50% of the Original Diameter (see FIG. 10)

| | |
|---------------------------------------|--------|
| Coronary stem (commercially available | 0.21b |
| Neurovascular Occluding device (30) | 0.021b |

[62] FIGS. 11-13 show an embodiment of the occluding device 60 in which the lattice structure 63 of the occluding device 60 is non-uniform across the length of the occluding device 60. In the mid-section 65 of the occluding device 60, which is the section likely to be deployed at the neck of the aneurysm, the lattice density 63a is intentionally increased to a value significantly higher than the lattice density elsewhere in the occluding device 60. For example, as seen in FIG. 11, lattice density 63A is significantly higher than the lattice density 63 in adjacent section 64. At one extreme, the lattice density (porosity provided by the interstices) could be zero, i.e., the occluding device 60 is completely impermeable. In another embodiment, the lattice density 63A in mid-section 65 could be about 50%, while the lattice density in the other sections 64 of the occluding device is about 25%. FIG. 12 shows such an occluding device 60 in a curved configuration and FIG. 13 shows this occluding device 60 deployed in the lumen of a vessel. FIG. 13 also illustrates the part of the occluding device 60 with increased lattice density 63A positioned along the neck of aneurysm 10. As with any of the disclosed occluding devices, the lattice density of at least one portion of occluding device 60 can be between about 20% and about 80%. The lattice density of these embodiments could be between about 25% and about 50%.

[63] Another embodiment of the occluding device 300 is shown in FIGS. 14 and 15. In this embodiment, the occluding device 300 is deployed in lumen of a vessel with an aneurysm. The occluding device 300 includes a surface 310 that faces the lumen of the aneurysm. This surface 310 has a significantly higher lattice density (smaller and/or fewer interstices) compared to the diametrically opposite surface 320. Due to the higher lattice density of surface 310, less blood flows into the lumen of the aneurysm. However, there is no negative impact on the blood flow to the side branches as the lattice density of the surface 320 facing the side branches is not reduced.

- [64]** As set forth in the examples above, different portions of the occluding device may have different lattice densities such that flow of fluids or blood may be controlled based on the location within the occluding device. The lattice densities may further be controlled by an input received at the occluding device. The input for controlling the lattice densities of different portions of the occluding device may include, for example, a pressure or motion force applied to a portion of the occluding device. The occluding device in this example may include helically-wound material such as strands or ribbons in a lattice structure as described herein. The strands that are helically wound may be movable relative to each other. For example, a first strand and a second strand may be helically wound to form a lattice structure that includes crossing strands (the first strand and the second strand may cross over each other) interspersed with openings between the strands.
- [65]** In another example, the lattice structure formed by crossing strands of the occluding device may be adjustable based on the input as described (e.g., motion, pressure or force input). When the input is received at the occluding device, the strands may move relative to each other. For example, a portion of the first strand may move closer to a corresponding portion of the second strand and a second portion of the first strand may also move farther from a corresponding first portion of the second strand. Hence, in this example, the spacing between the first and second strands of helically wound material forming the lattice structure of the occluding device may vary to create different lattice densities. Different portions of an occluding device may have different lattice densities when strands in one portion of the occluding device move closer to each other while strands in another portion of the occluding device move farther away from each other.
- [66]** Also, the relative movement of the strands may be controlled based on an input received at the occluding device. As set forth above, the input may include any type of input for moving or adjusting the occluding device including, for example, pressure, force, motion, rotation, or other similar input.
- [67]** The occluding device may be placed into a blood vessel and a certain portion of the occluding device may contain a high lattice density while retaining a lower lattice density in a different portion of the occluding device. The received input may control the placement and/or lattice density of the occluding device to achieve a desired

lattice density at a selected portion of the occluding device. Thus, the input received at the occluding device may cause a first portion of the occluding device to have a first lattice density and a second portion of the occluding device to have a second lattice density in which the first lattice density and the second lattice density are different.

- [68] In one example, a user may insert the occluding device into the blood vessel and may apply pressure on the occluding device to cause an adjustment of the lattice density of the occluding device. In another example, a motion force may be applied to the occluding device such that the strands of the occluding device forming the lattice structure may move relative to one another in at least one portion of the occluding device. The strands may also be rearranged differently at different portions of the occluding device such that the lattice density may vary from one portion of the occluding device to another portion of the occluding device.
- [69] For example, the occluding device may include a lattice density adjusting implement such that pressure exerted by the lattice density adjusting implement on a portion of the occluding device may cause the lattice density of the portion of the occluding device acted upon by the lattice density adjusting implement to obtain a desired lattice density. FIG. 17 illustrates an example of an occluding device 1701 containing a lattice density adjusting implement 1702 for adjusting the lattice density at any desired portion of the occluding device 1701. The user may exert a force on a proximal end of the lattice density adjusting implement 1702 which may cause a distal end of the lattice density adjusting implement to adjust the lattice material for altering the lattice density. In addition, movement of the lattice density adjusting implement 1702 may enable a user to adjust the lattice density of any desired portion of the occluding device.
- [70] The occluding device may further be administered and positioned into a vessel via a delivery device. For example, a delivery device may include a tubular structure such as a catheter through which the occluding device may be placed into a vessel. The delivery device may further include the lattice density adjusting implement 1702 that may be used to adjust the lattice density of the occluding device. The lattice density adjusting implement 1702 may further adjust the lattice density only at one portion of the occluding device while not affecting other portions of the occluding device, if desired. Alternatively, the lattice density adjusting implement 1702 may be used to

increase the lattice density at one portion of the occluding device while decreasing the lattice density at another portion of the occluding device. The lattice density adjusting implement 1702 may be controlled by pressure or motion forces applied via the delivery device.

- [71] In one example, the lattice density adjusting implement 1702 may be connected to a wire to a proximal end of the delivery device. The user may apply a force to the proximal end of the wire at the proximal end of the delivery device. The force applied which may be a pressure or motion force, for example, may cause corresponding movement of the lattice density adjusting implement 1702. The movement of the lattice density adjusting implement 1702 may further contact strands of the occluding device to move the strands. The movement of the strands of the occluding device may cause a change in the lattice density in at least one portion of the occluding device. Hence, user input may control a lattice density adjusting implement 1702 to cause varying lattice densities in selected portions of the occluding device.
- [72] In another example, the lattice density of the occluding device may be adjusted based on movement of the occluding device in a blood vessel. For example, the occluding device may be placed and moved within a blood vessel. As the occluding device is moved in the blood vessel, the lattice density in selected portions of the occluding device may be adjusted accordingly. The lattice density in one portion of the occluding device may increase while the lattice density in another portion of the occluding device may increase, decrease or stay the same. In one example, the occluding device contacts a wall of the blood vessel and a force is applied to a proximal end of the occluding device. For example a user may apply a force to a proximal end of the occluding device. This force, which may be a pressure or motion force, for example, may be applied at a proximal end of a delivery device through which the occluding device may be positioned in a vessel and may be adjusted in the vessel. The applied force causes the strands or ribbons of the occluding device to adjust such that the lattice density in the occluding device varies based on the portion of the occluding device.
- [73] As one example, the occluding device contains intertwining ribbons forming a lattice structure with a lattice density. The occluding device is introduced to a site in a blood vessel of an aneurysm. The occluding device is further applied to the portion of the

blood vessel at and around the aneurysm as illustrated in FIG. 7. The outer sides of the occluding device may be in contact with at least a portion of the blood vessel in areas surrounding the aneurysm, however, the outer side of the occluding device at the site of the aneurysm does not contact a wall of the blood vessel. This may be because the aneurysm is situated such that the wall of the aneurysm protrudes outward from the wall of the surround blood vessel such that the outer sides or surface of the occluding device does not directly contact the inner surface of the wall of the aneurysm.

- [74] Pressure may be applied to, for example, a proximal end of the occluding device. In this example, the lattice structure of the occluding device is freely adjustable such that the pressure may cause movement of the lattice structure of the occluding device in a distal direction. Frictional forces acting on the occluding device from the inner surface of the walls of the blood vessel in contact with the outer sides or surfaces of the occluding device may impede movement of the lattice structure in areas of the occluding device in contact with the wall of the blood vessel. However, gradual movement of the occluding device in the blood vessel is accomplished by continued application of pressure at the proximal end of the occluding device (in this example).
- [75] The portion of the occluding device overlying the neck of the aneurysm does not contact the walls of the blood vessel in this example. Because this portion of the occluding device subject to less frictional forces as compared to the portion of the occluding device in direct contact with the inner wall of the blood vessel, the lattice structure of the occluding device overlying the aneurysm may change as the applied force causes the portion of the occluding device proximal to the aneurysm to move distally to cause an increase in force applied to the portion of the occluding device overlying the aneurysm. Also, the section of the occluding device overlying the blood vessel wall distal to the aneurysm may be subject to higher frictional forces than that applied to the portion of the occluding device overlying the aneurysm. As a result, in this example, the lattice density of the occluding device overlying the aneurysm is increased. At the same time, the lattice density of the portion of the occluding device either does not increase or increases to a lesser degree than the portion of the occluding device overlying the aneurysm.

- [76] In another example, an aneurysm may be located at a branching of a blood vessel as illustrated in FIG. 18. The occluding device is placed such that a first portion 1801 of the occluding device may be located proximal to a blood vessel branch and aneurysms. A second portion 1802 of the occluding device may be located overlying the blood vessel branch 1808, a third portion of the occluding device may be located overlying a portion of the blood vessel distal to the blood vessel branch 1808 and proximal to a first aneurysm 1809, a fourth portion of the occluding device may be located overlying the first aneurysm 1809, a fifth portion of the occluding device may overlie the portion of the blood vessel distal to the first aneurysm 1809 and proximal to a second aneurysm 1810. A sixth portion of the occluding device may overlie the second aneurysm 1810. Blockage of blood flow to the aneurysms may be desired, however, blockage of blood flow to the branched blood vessel may not be desired.
- [77] In this example, a user may apply a pressure or force to a proximal end of an occluding device to cause a portion of the occluding device to advance in the blood vessel in a distal direction. The first portion 1801 of the occluding device (proximal to the blood vessel branch 1808 and the aneurysms 1809 and 1810) may transmit the force to more distal portions of the occluding device, including the second portion 1802 of the occluding device located over the blood vessel branch 1808. The frictional force impeding advancement of the occluding device in the second portion 1802 of the occluding device is low because the second portion 1802 of the occluding device does not contact the wall of the blood vessel directly. Rather, the second portion 1802 of the occluding device overlies a blood vessel branch 1808 as illustrated in FIG. 18. Hence, the lattice density in the second portion 1802 of the occluding device increases as the first portion 1801 of the occluding device transfers the force to the second portion 1802 of the occluding device. Also a negative force applied to the occluding device may cause the lattice density in the second portion 1802 of the occluding device to decrease, thus permitting flow of blood into the blood vessel branch 1808.
- [78] The second portion 1802 of the occluding device also transfers the force to the third portion 1803 of the occluding device overlying the portion of blood vessel distal to the blood vessel branch 1808. However, the frictional forces acting on the third portion 1803 of the occluding device is higher than those frictional forces acting on the second portion 1802 because the third portion 1803 of the occluding device is in

contact with the wall of the blood vessel. Hence, the lattice density of the occluding device in the third portion 1803 is initially lower than the lattice density of the occluding device in the second portion 1802.

- [79] The force applied to the third portion 1803 of the occluding device (overlying and in contact with the portion of the blood vessel distal to the blood vessel branch 1808 and first aneurysm 1809) is transferred to the fourth portion 1804 of the occluding device, which is the portion of the occluding device overlying the first aneurysm 1809. The frictional forces acting on the fourth portion 1804 of the occluding device is lower than the frictional forces acting on the third portion 1803 of the occluding device because the fourth portion 1804 of the occluding device is not in direct contact with the inner wall of the blood vessel. Hence, the pressure applied to the fourth portion 1804 of the occluding device causes the lattice density in the fourth portion 1804 of the occluding device to increase.
- [80] Also, the force applied to the fourth portion 1804 of the occluding device may be transferred to the fifth portion 1805 of the occluding device, which is in contact with the portion of the blood vessel between the first aneurysm 1809 and the second aneurysm 1810. The frictional force acting on the fifth portion 1805 of the occluding device is greater than the frictional force acting on the fourth portion 1804 of the occluding device because at least a portion of the fifth portion 1805 of the occluding device is in contact with the inner wall of the blood vessel. However, the fourth portion 1804 of the occluding device overlies the second aneurysm 1809 and is not in contact with the wall of the blood vessel. Hence, the difference in the frictional forces applied to the portions of the occluding device results in controlled changes in the lattice density of different portions of the occluding device in this example.
- [81] Also illustrated in FIG. 18 is the sixth portion 1806 of the occluding device that overlies the second aneurysm 1810. The frictional forces acting upon the sixth portion 1806 of the occluding device is less than the frictional force acting on the fifth portion of the occluding device 1805 because the sixth portion 1806 of the occluding device does not contact a wall of the blood vessel directly. Therefore, the force transferred from the fifth portion 1805 of the occluding device to the sixth portion 1806 of the occluding device may cause the lattice density of the sixth portion 1806 to increase. Hence, the lattice density of the fourth portion and the sixth portion of the occluding

device may be increased by application of a pressure or motion force at the occluding device. Also, retraction of the occluding device such as by pulling a proximal end of the occluding device proximally may cause the lattice density of the second portion of the occluding device to decrease. This may cause increased flow of blood and/or fluids into the blood vessel branch 1808 while impeding flow of blood and/or fluids into the first or second aneurysms (1809, 1810).

- [82] Any of the occluding devices disclosed herein can be used with a second occluding device to create a bifurcated occluding device 400 as shown in Figure 16. This device could be created *in vivo*. In forming the occluding device 400, a portion of a first occluding device 410 having a low density can be combined with a portion of a second occluding device 410 that also has a low density. The occluding devices 410, 420 can be any of those discussed herein. After these portions of the two occluding devices 410, 420 are combined in an interwoven fashion to form an interwoven region 425, the remaining portions 414, 424 can branch off in different directions, thereby extending along two branches of the bifurcation. Areas outside of the interwoven region 425 can have greater lattice density for treating an aneurysm or lesser lattice density for allowing flow to branches 15, 16 of the vessel.
- [83] The density of the lattice for each of the disclosed occluding devices can be about 20% to about 80% of the surface area of its occluding device. In an embodiment, the lattice density can be about 20% to about 50% of the surface area of its occluding device. In yet another embodiment, the lattice density can be about 20% to about 30% of the surface area of its occluding device.
- [84] In another example, the lattice density of an occluding device may be adjusted or altered by user input such as a user input motion. The input motion may be in a longitudinal orientation. For example, an input force or pressure may in a direction along a longitudinal axis of the occluding device may be received at a portion of the occluding device. The portion of the occluding device may have a lattice density prior to the application of the force, pressure or movement of the strands of the occluding device in the portion of the occluding device receiving the input force. The lattice density in the portion of the occluding device may change based on the received input. For example, the strands of the occluding device may move in a longitudinal direction in the occluding device. Also, the longitudinal movement of strands of the

occluding device may occur at a portion of the occluding device or may occur at the entire occluding device. In the example of longitudinal movement of strands of the occluding device at a portion of the occluding device, the strands at the portion of the occluding device may move based on the received input such that the lattice density of the occluding device at the portion of the occluding device receiving the input may increase. Alternatively, the lattice in a portion of the occluding device may also decrease in response to the input force, pressure or motion. Also, based on the input force, pressure, or motion, the lattice density in a first portion of the occluding device may increase while the lattice density in a second portion of the occluding device may decrease or stay the same. Hence, different portions of the occluding device may have a different movement based on an input received at the occluding device such that one portion of the occluding device may have an increase or decrease in lattice density while any other portion of the occluding device may have a decrease or increase in the lattice density. Alternatively, the lattice density in any of the portions of the occluding device may stay the same.

- [85] A typical occluding device having sixteen strand braids with 0.005 inch wide ribbon, 30 picks per inch (PPI) (number of crosses/points of contact per inch), and 0.09 inch outer diameter has approximately 30% of lattice density (surface covered by the ribbon). In the embodiments disclosed herein, the ribbon can be about 0.001 inch thick with a width of between about 0.002 inch to about 0.005 inch. In an embodiment, the ribbon has a thickness of about 0.004 inch. For a 16-strands ribbon that is about 0.001 inch thick and about 0.004 inch wide, the coverage for 50 PPI, 40 PPI, and 30 PPI will have 40%, 32% and 24% approximate surface coverage, respectively. For a 16-strands ribbon that is about 0.001 inch thick and about 0.005 inch wide, the coverage for 50 PPI, 40 PPI, and 30 PPI will be about 50%, 40% and 30% approximate surface coverage, respectively.
- [86] In choosing a size for the ribbon, one must consider that, when the ribbons are bundled up, will they traverse through a micro-catheter. For example, sixteen strands of a 0.006 inch wide ribbon may not pass through a micro-catheter having an internal diameter of 0.027 inch or less. However, as the width of ribbons become smaller, the recovery strength may decrease proportionally.

- [87]** While other strand geometry may be used, these other geometries, such as round, will limit the device due to their thickness dimension. For example, a round wire with a 0.002 inch diameter will occupy up to 0.008 inch in cross sectional space within the vessel. This space can impact and disrupt the blood flow through the vessel. The flow in the vessel can be disrupted with this change in diameter.
- [88]** Although the detailed description contains many specifics, these should not be construed as limiting the scope of the invention but merely as illustrating different examples and aspects of the invention. It should be appreciated that the scope of the invention includes other embodiments not discussed in detail above. Various other modifications, changes and variations which will be apparent to those skilled in the art may be made in the arrangement, operation and details of the method and apparatus of the present invention disclosed herein without departing from the spirit and scope of the invention as defined in the appended claims. Therefore, the scope of the invention should be determined by the appended claims and their legal equivalents. Furthermore, no element, component or method step is intended to be dedicated to the public regardless of whether the element, component or method step is explicitly recited in the claims.
- [89]** In the claims, reference to an element in the singular is not intended to mean "one and only one" unless explicitly stated, but rather is meant to mean "one or more." In addition, it is not necessary for a device or method to address every problem that is solvable by different embodiments of the invention in order to be encompassed by the claims.

What is claimed is:

1. A system, for treatment of an aneurysm, comprising:
 - a tubular-shaped device for positioning by a user within a blood vessel for treatment of an aneurysm, the device including a plurality of strands of helically-wound material in a lattice structure, wherein the device is self-expandable to a first expanded tubular configuration, such that the device engages an inner surface of a blood vessel with a surface of the device being apposed to the vessel surface, the first expanded tubular configuration having a first porosity in a first portion and in a second portion along a length of the tubular-shaped device, the second portion being adjustable, after engagement of the device with the vessel surface, along a length of the second portion to change the device into a second expanded tubular configuration based on an input by the user while the device remains engaged with the vessel surface, such that the second portion acquires a second porosity, different from the first porosity, while the first portion maintains the first porosity;
 - an elongate member configured to be positioned in the blood vessel, engage the device, and change the device from the first configuration to the second configuration based on the input;
 - wherein the input comprises movement, by the user, of the elongate member in contact with the device.
2. The system of claim 1, wherein the first porosity is lower than the second porosity and wherein flow of blood through the lattice structure at the first porosity is higher than flow of blood through the lattice structure at the second porosity.
3. The system of claim 1, wherein the first porosity is lower than the second porosity and wherein the first portion of the lattice structure is configured to overlie the aneurysm.
4. The system of claim 3, wherein the second portion of the lattice structure is configured to be spaced from the aneurysm.

5. The system of claim 4, wherein the second portion of the lattice structure is configured to abut a blood vessel lumen.
6. The system of claim 1, wherein the input comprises motion in a longitudinal direction relative to the device.
7. The system of claim 1, wherein the plurality of strands of helically-wound material comprises members.
8. The system of claim 7, wherein the helically-wound material comprises less than 16 strands of members.
9. The system of claim 7, wherein each member has a different width.
10. The system of claim 1, wherein the device is radially compressible.
11. The system of claim 1, further comprising longitudinally extending areas of different densities.
12. The system of claim 11, wherein circumferential densities of the longitudinally extending areas vary based on the areas of different densities.
13. The system of claim 1, wherein the plurality of strands of helically-wound material comprises a plurality of woven members, each said member comprising an inner surface and an outer surface configured to be positioned adjacent an inner wall of a vessel and forming a portion of an outer circumference of the device between first and second ends of the device, wherein a plurality of openings extends between the inner surface and the outer surface, the outer surface of the members comprising between about 20 percent and about 50 percent of the total circumferential area of the device.
14. The system of claim 1, wherein the lattice structure at the first porosity restricts fluid flow there through in a direction at an angle to a length of the device and the lattice

structure at the second porosity permits greater fluid flow there through relative to the lattice structure at the first porosity.

15. The system of claim 1, wherein the input comprises an applied force at a portion of the device, the applied force causing a first porosity at a first portion of the device and a second porosity at a second portion of the device.

16. The system of claim 15, wherein the applied force comprises a rotation force applied to an end portion of said device.

17. The system of claim 1, wherein at least one of the first porosity and the second porosity is adjustable based on a second input.

18. The system of claim 1, wherein the plurality of strands is braided and comprises a first plurality of strands of a first metallic material winding in a first direction; a second plurality of strands, of a second metallic material, different from the first metallic material, winding in the first direction; and a third plurality of strands, of one of the first metallic material and the second metallic material, winding in a second direction, opposite the first direction, and wherein the first metallic material comprises platinum.

19. The system of claim 18, wherein the second metallic material comprises at least one of nitinol and stainless steel.

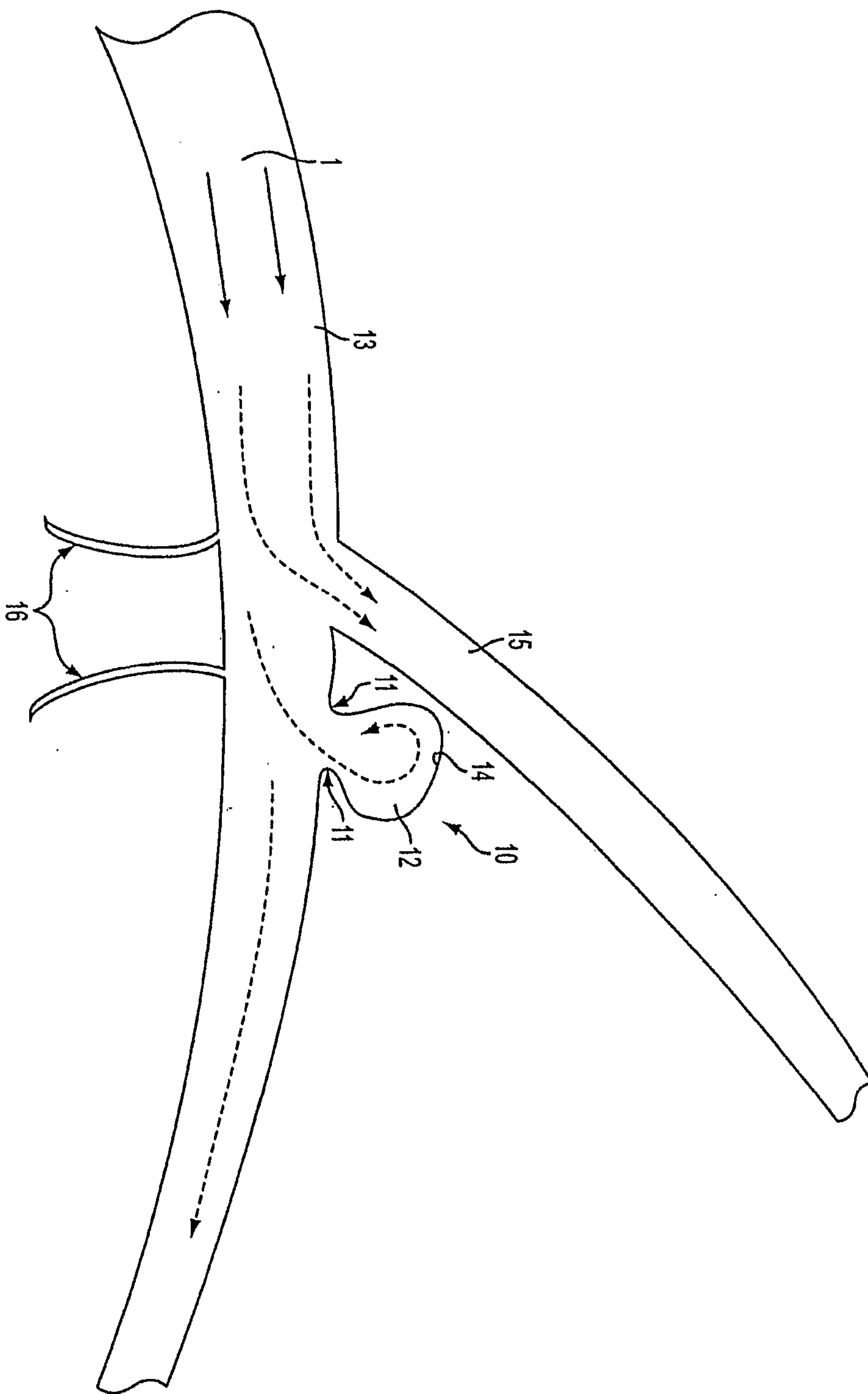

FIG. 1

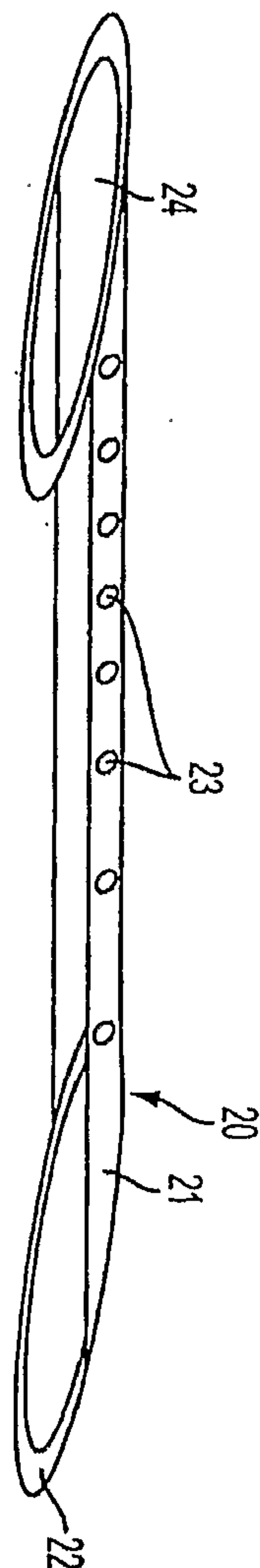

FIG. 2A

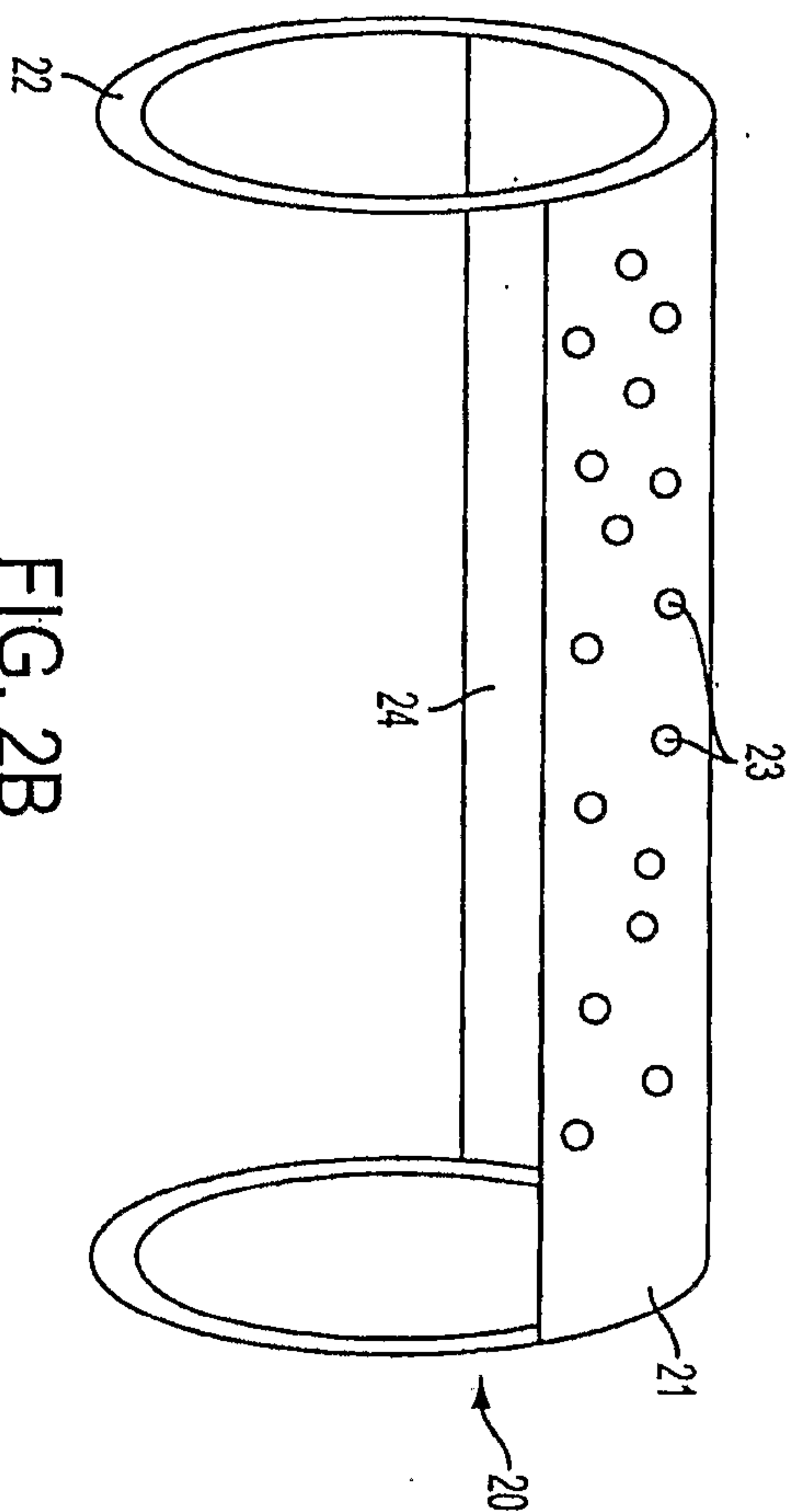

FIG. 2B

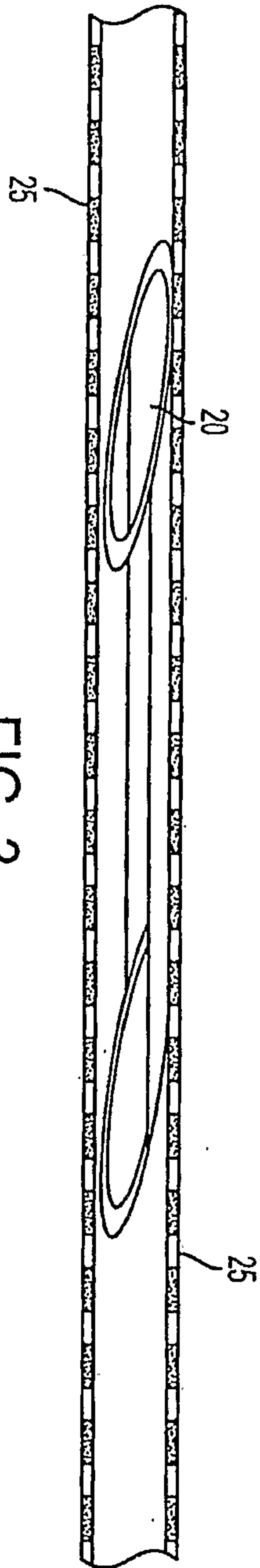

FIG. 3

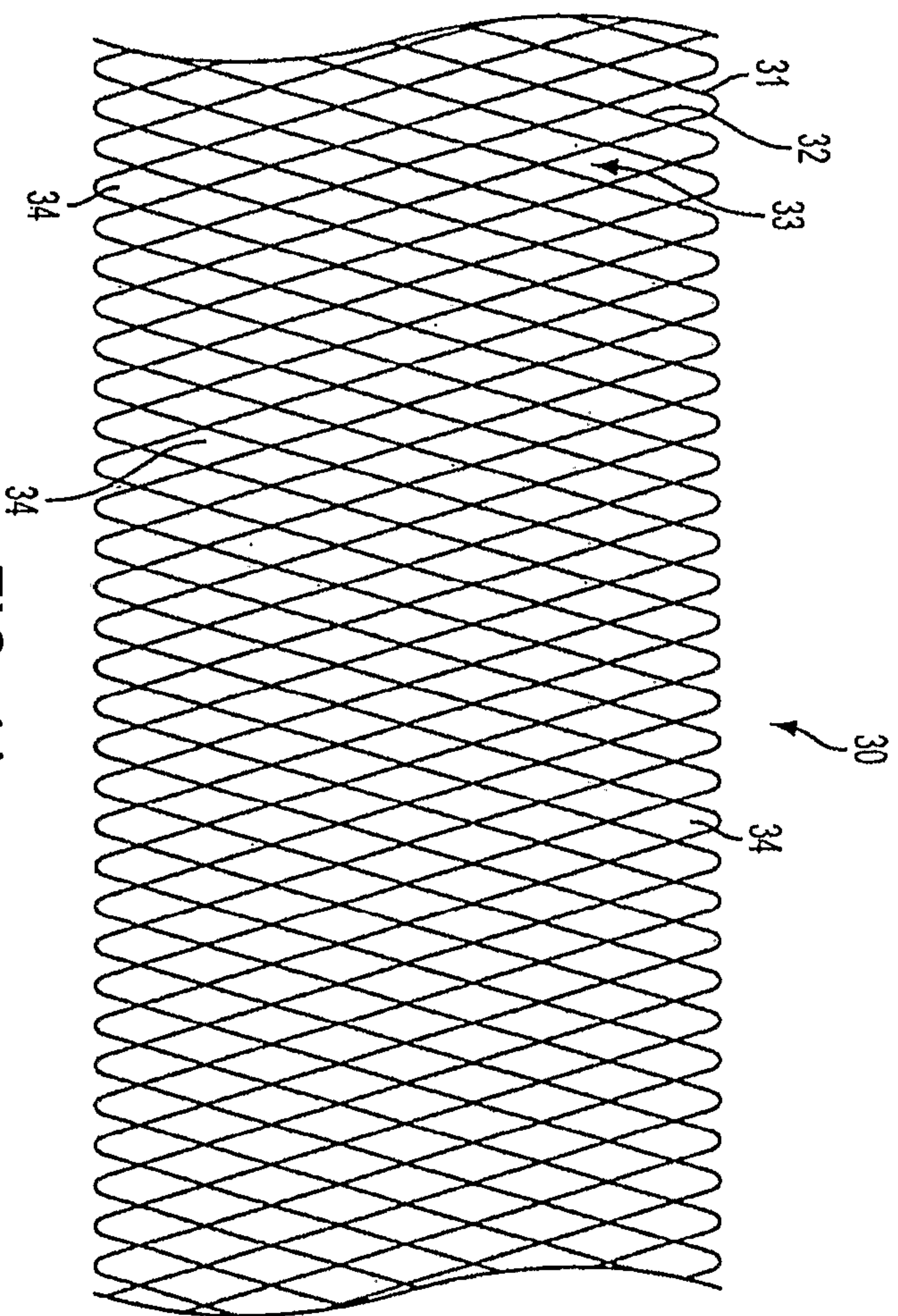

FIG. 4A



FIG. 4B

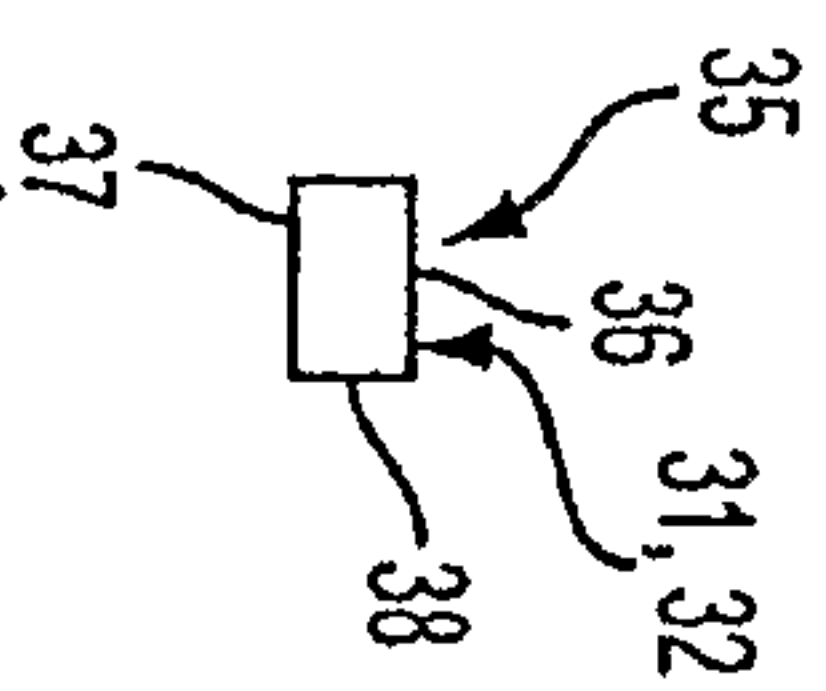

FIG. 4C

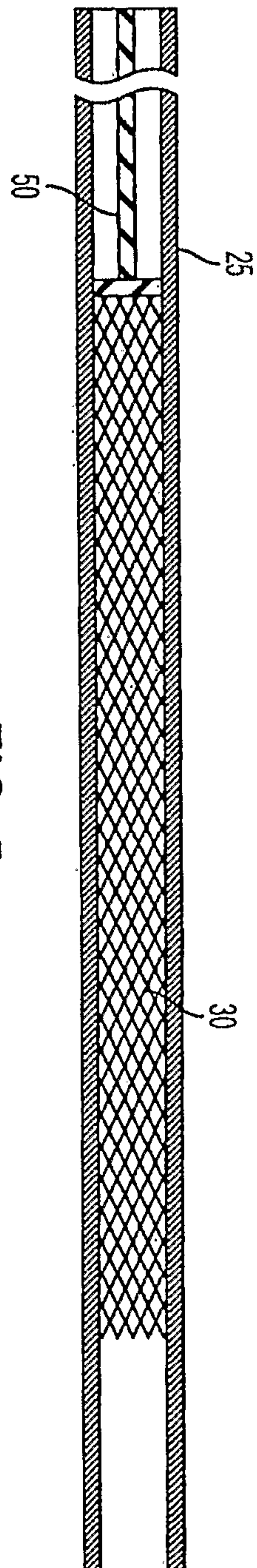

FIG. 5

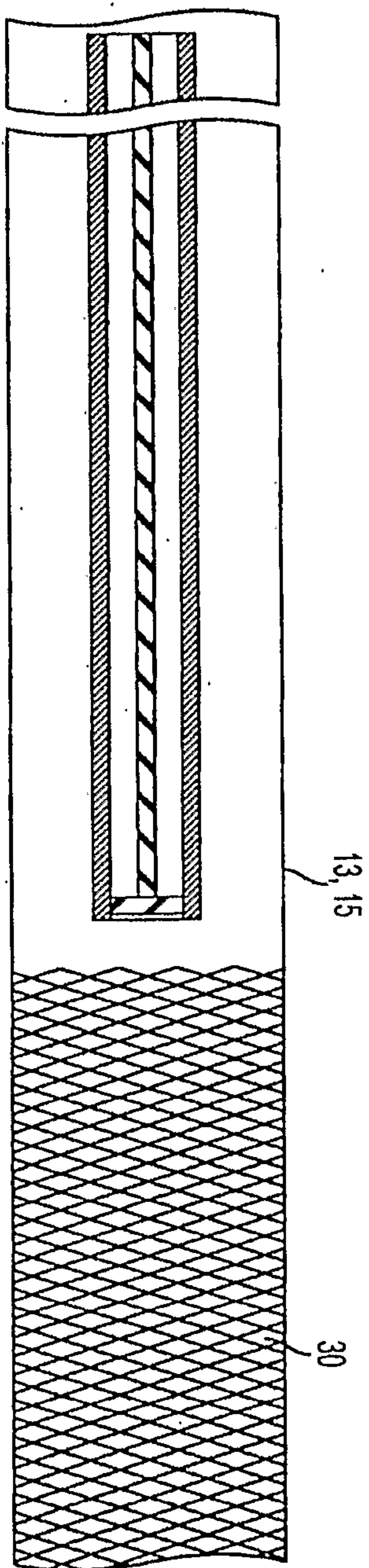

FIG. 6

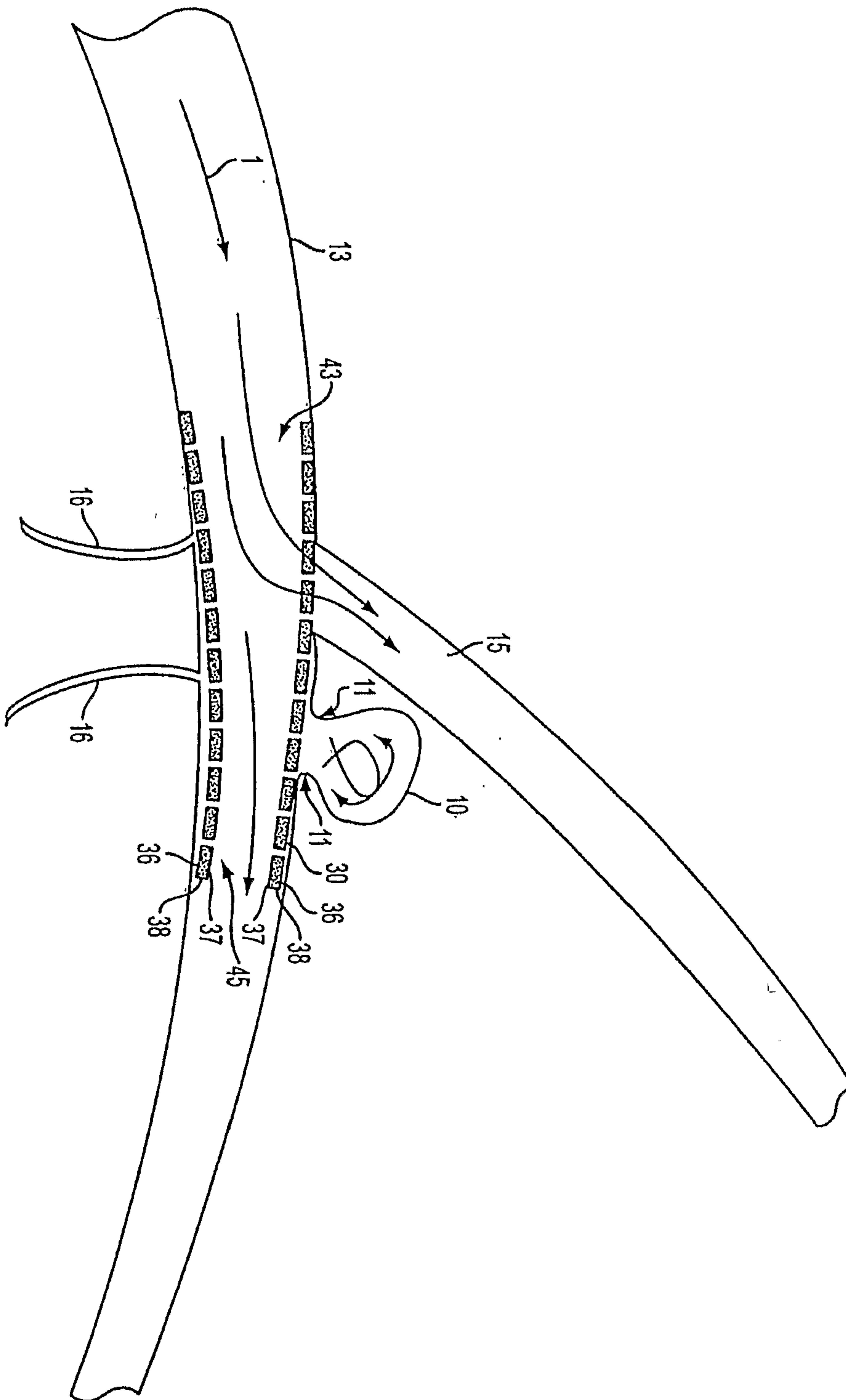

FIG. 7

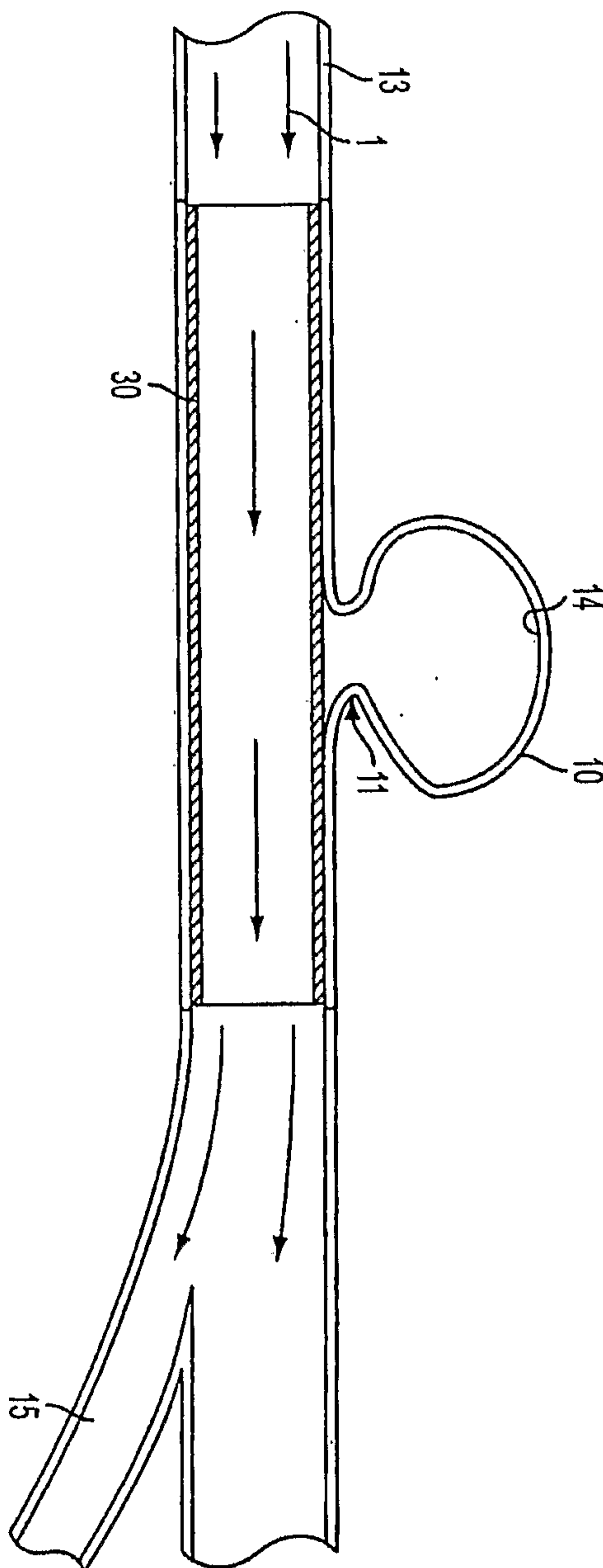
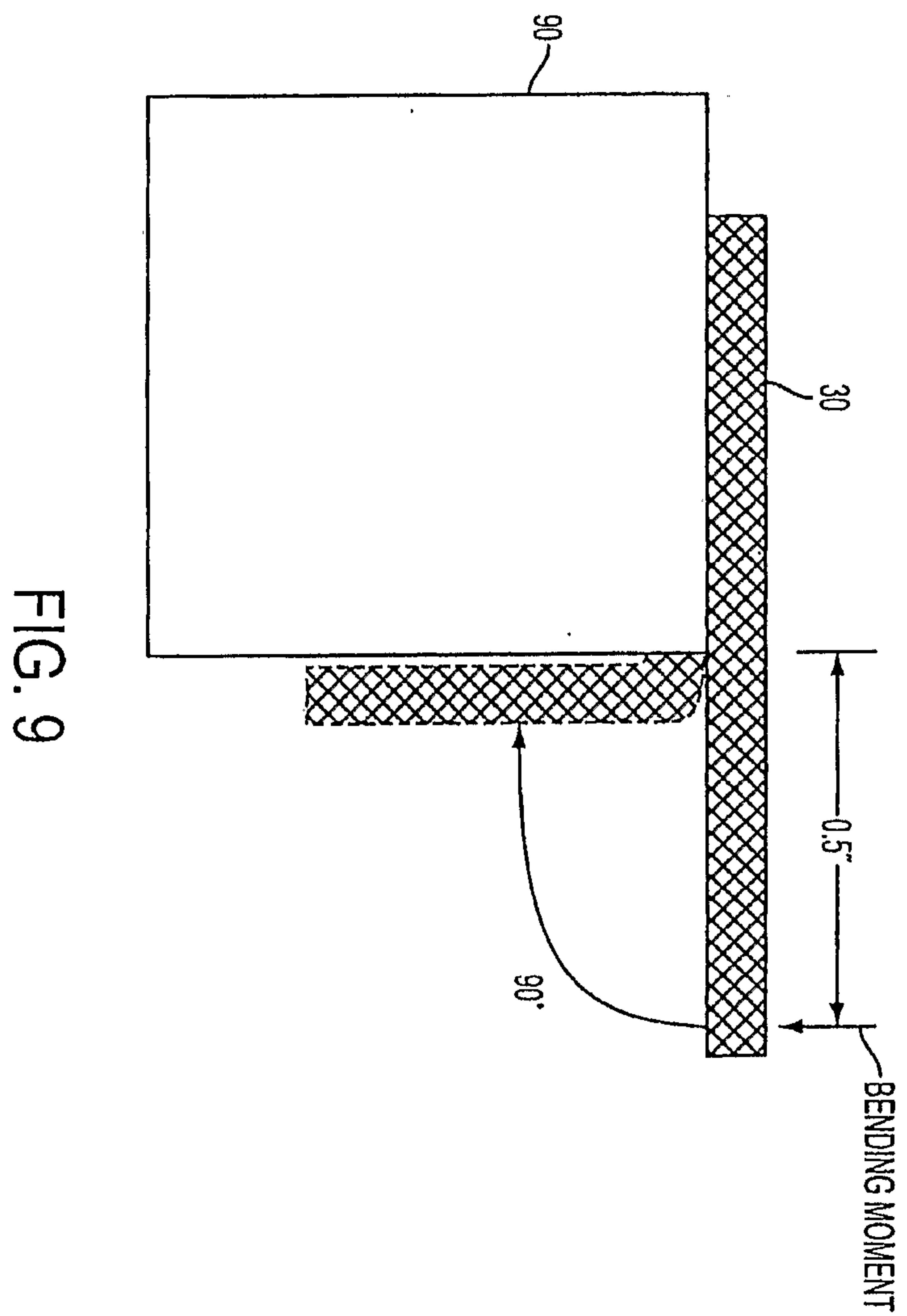
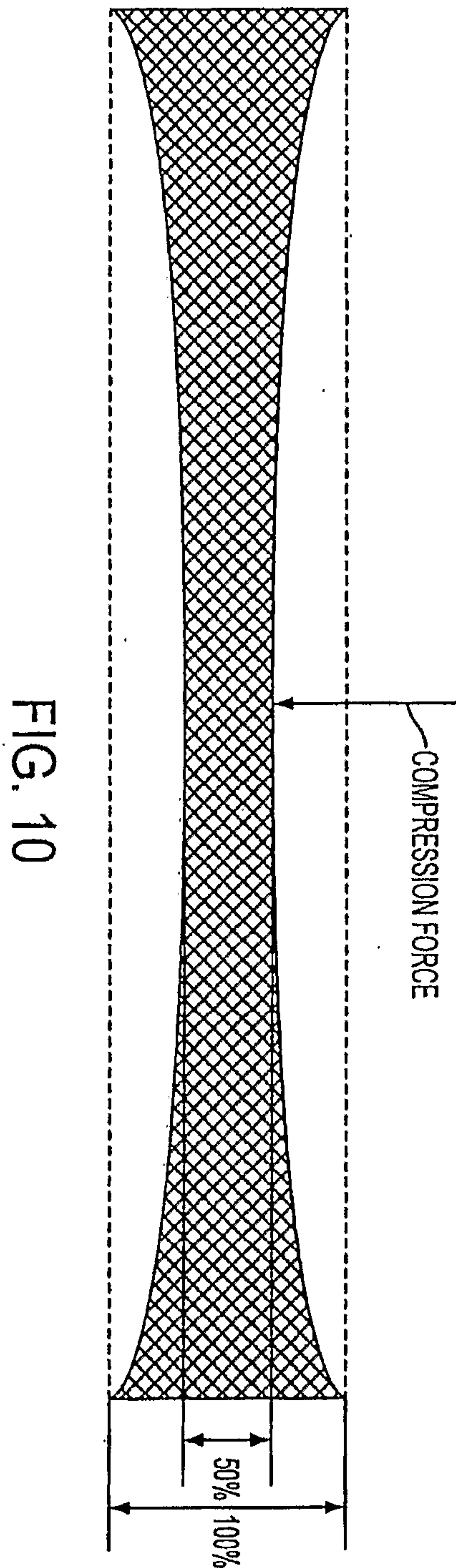
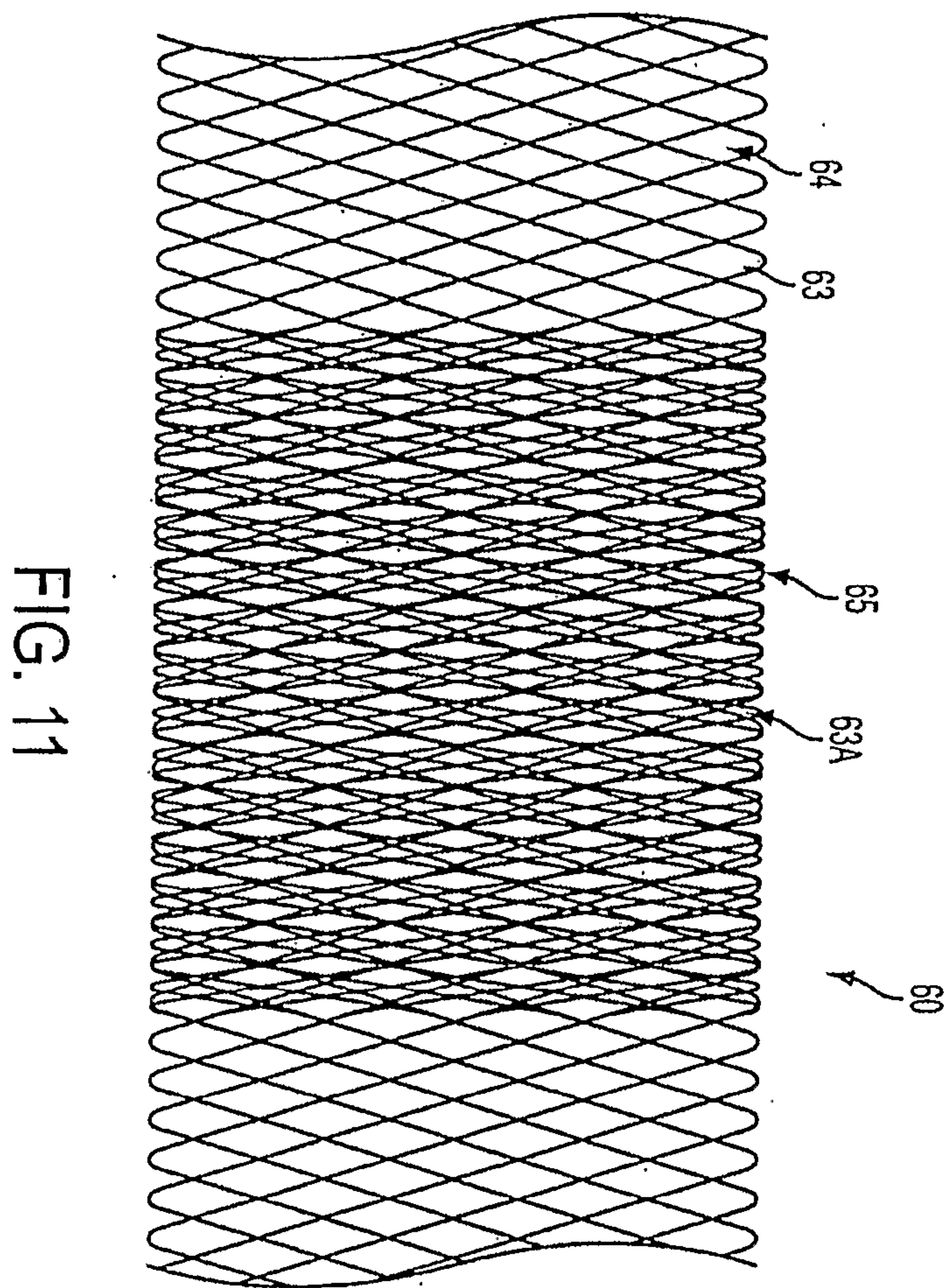

FIG. 8







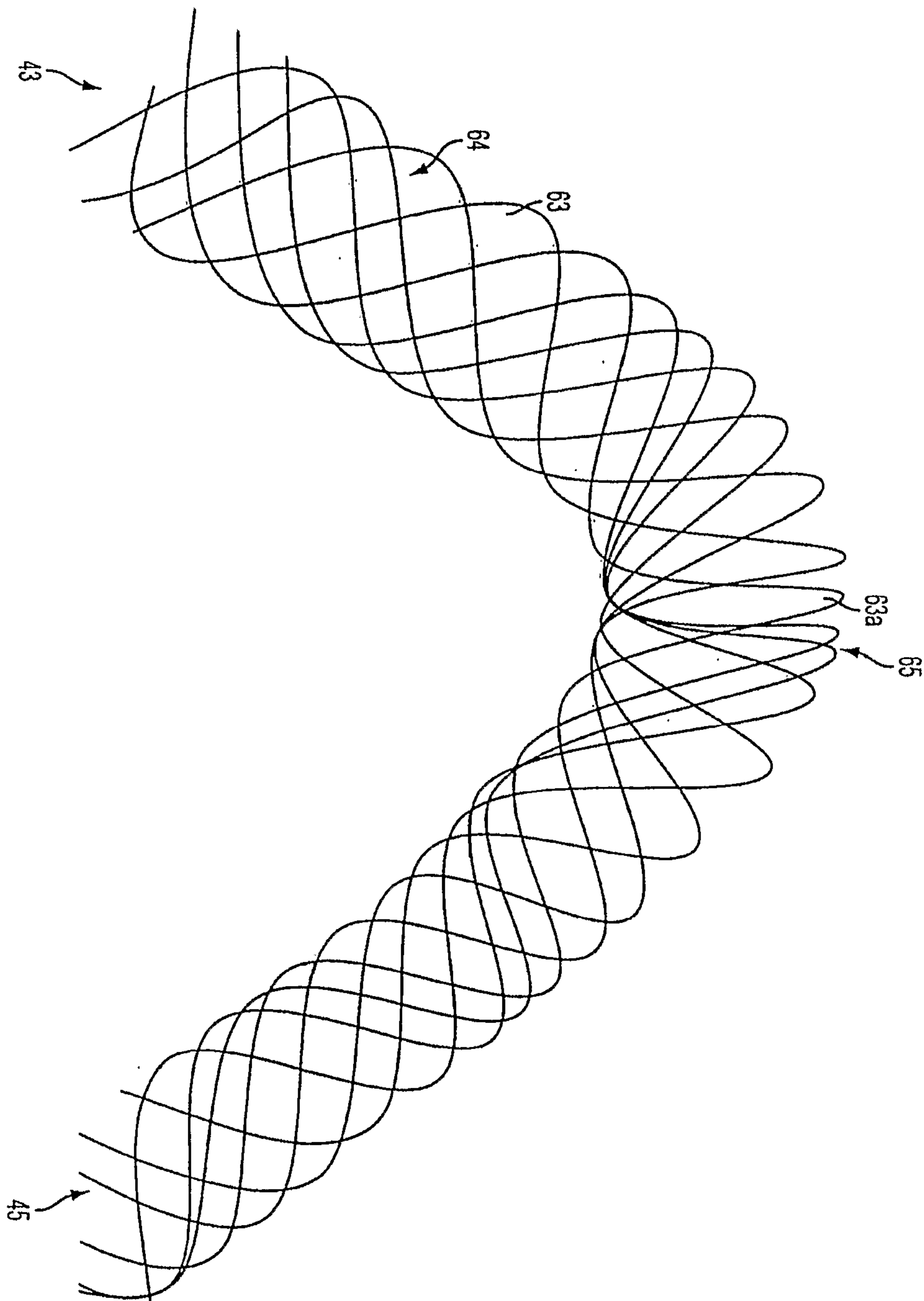

FIG. 12

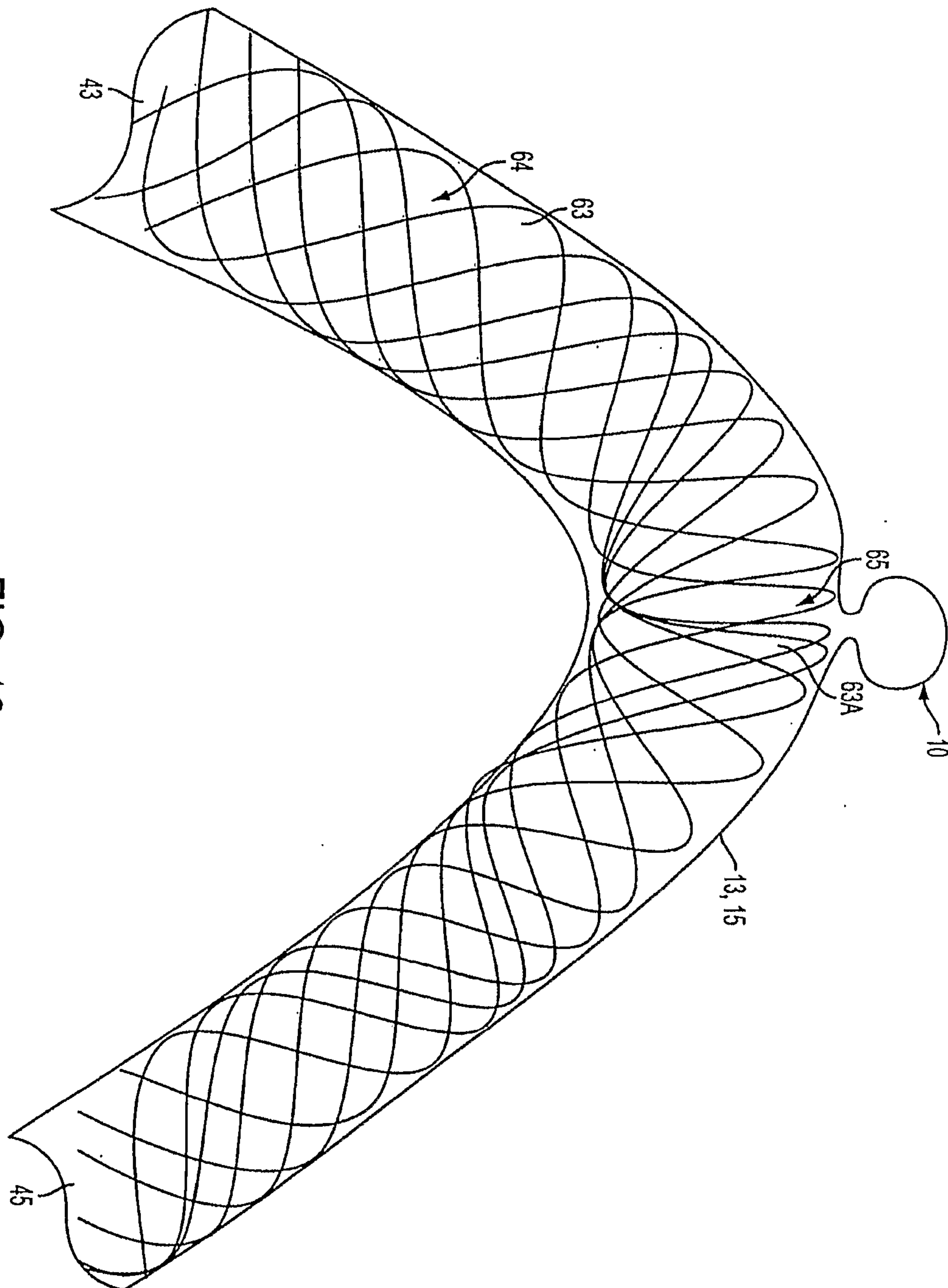

FIG. 13

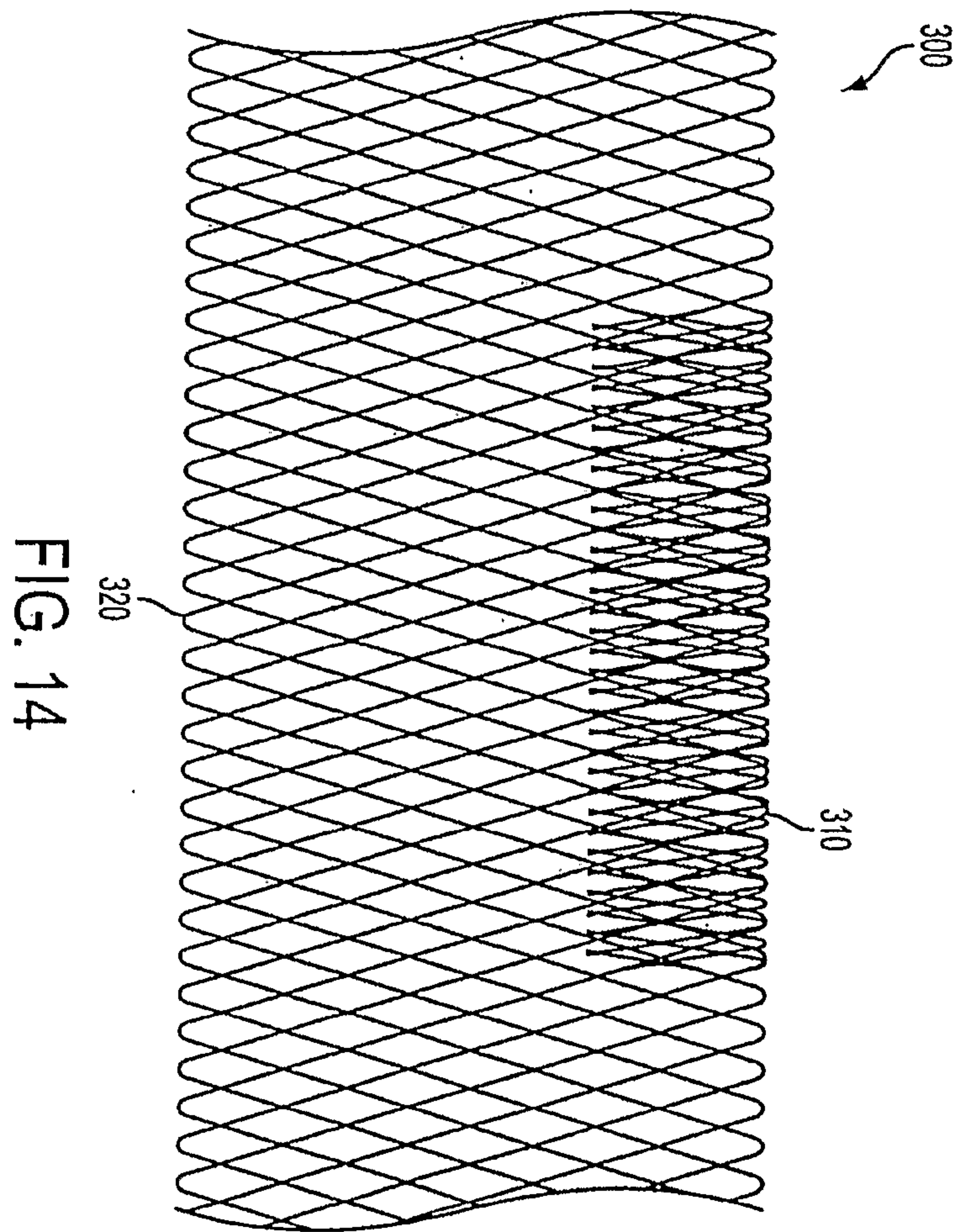

FIG. 14

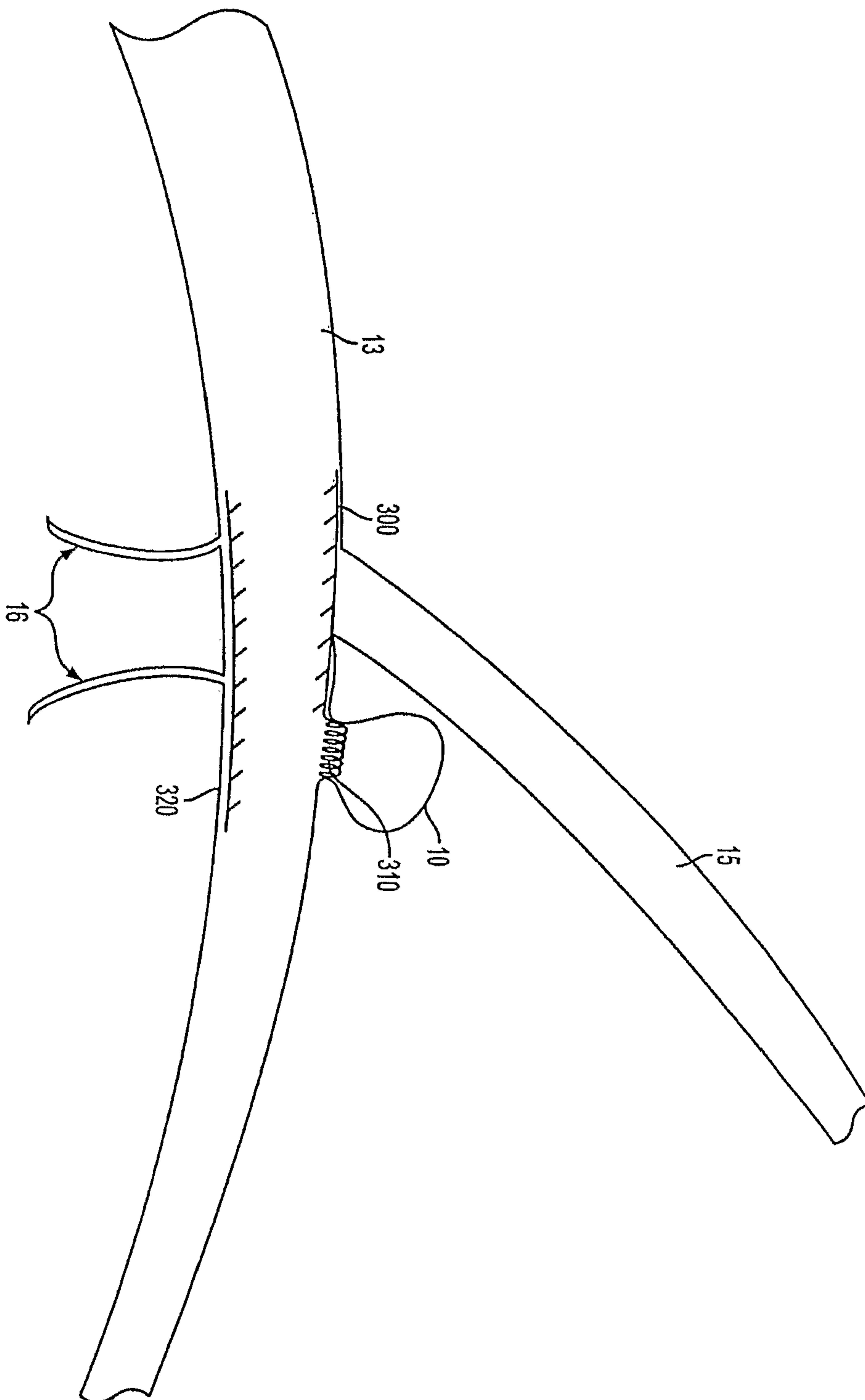

FIG. 15

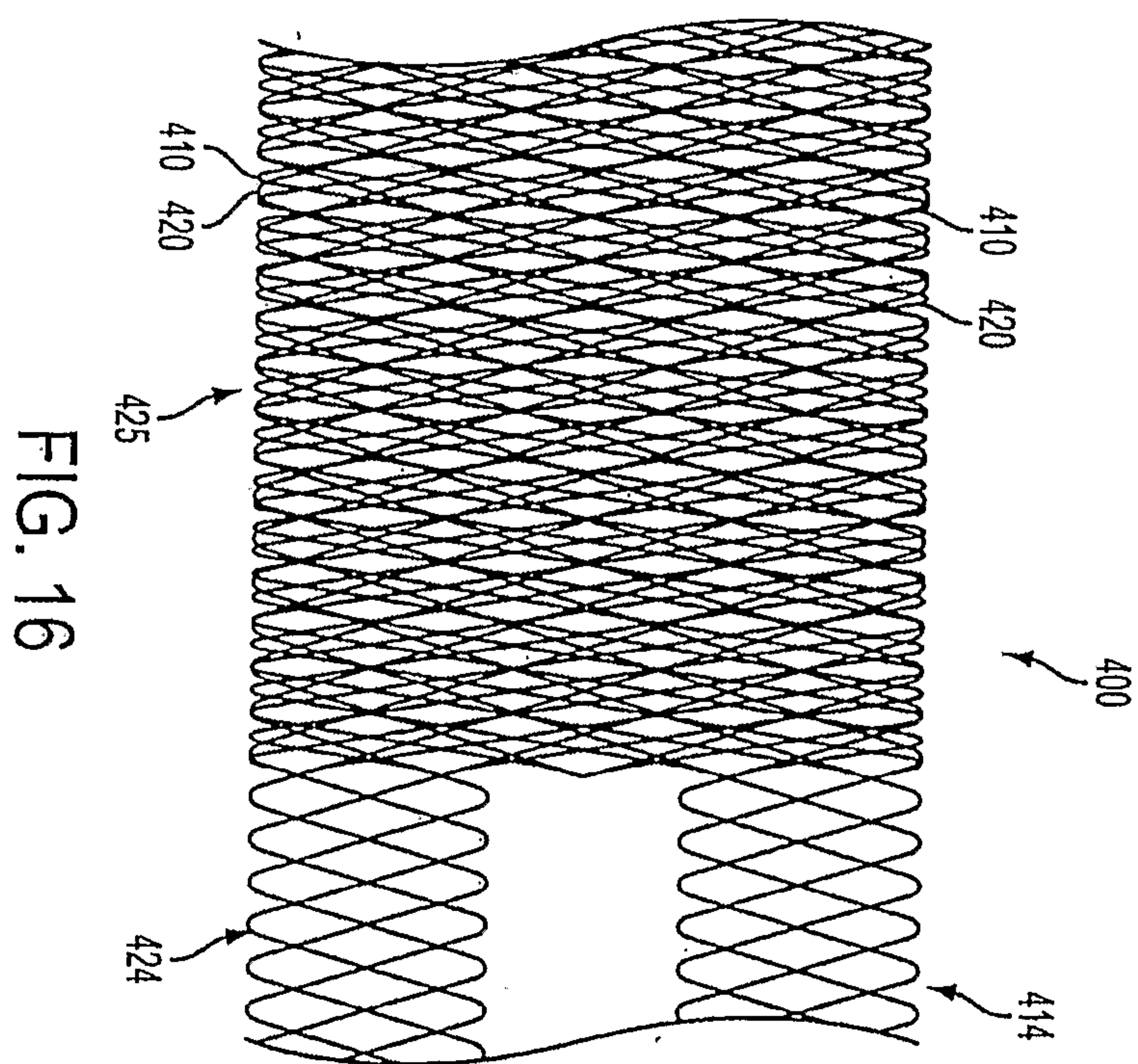

FIG. 16

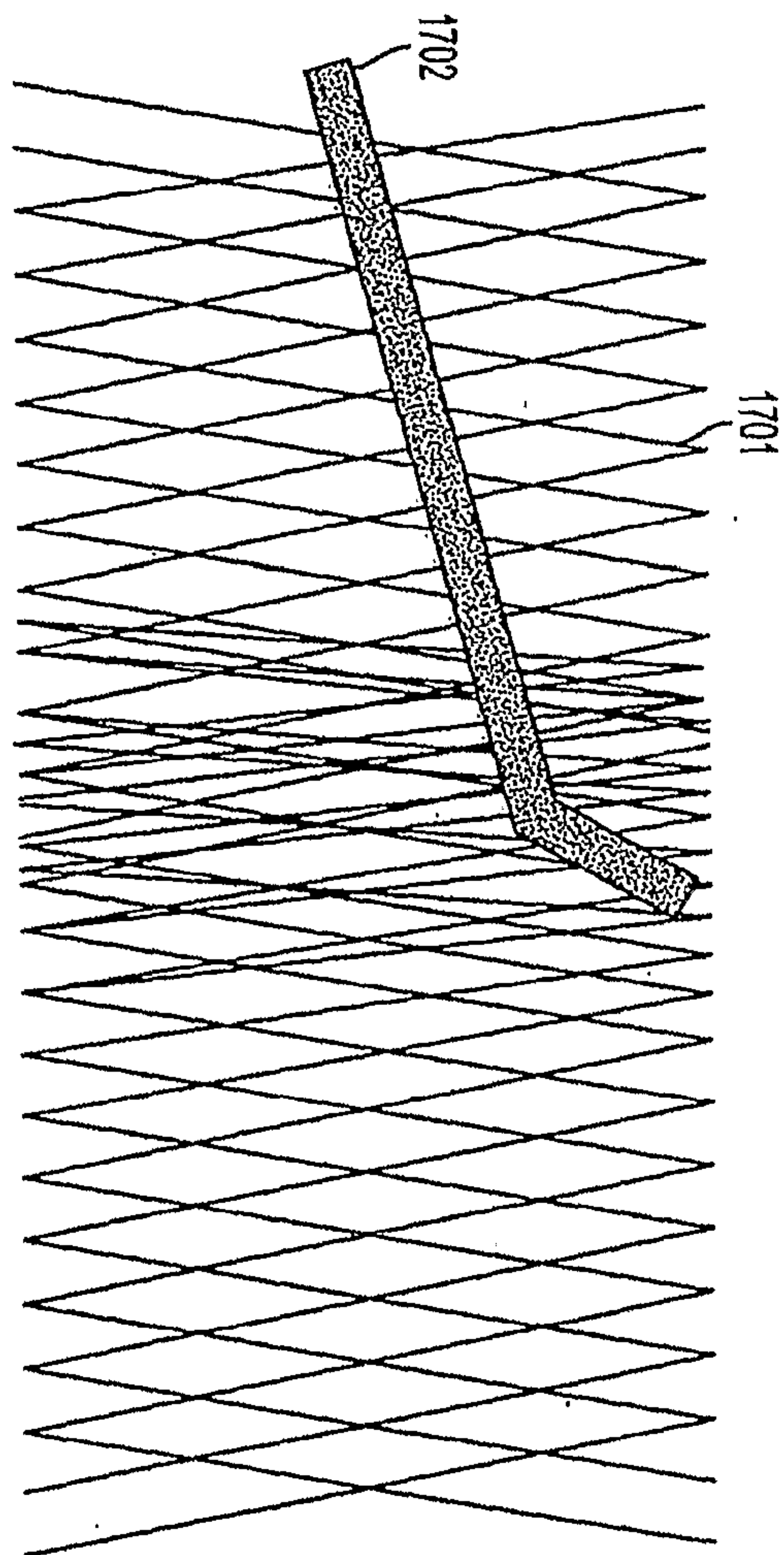

FIG. 17

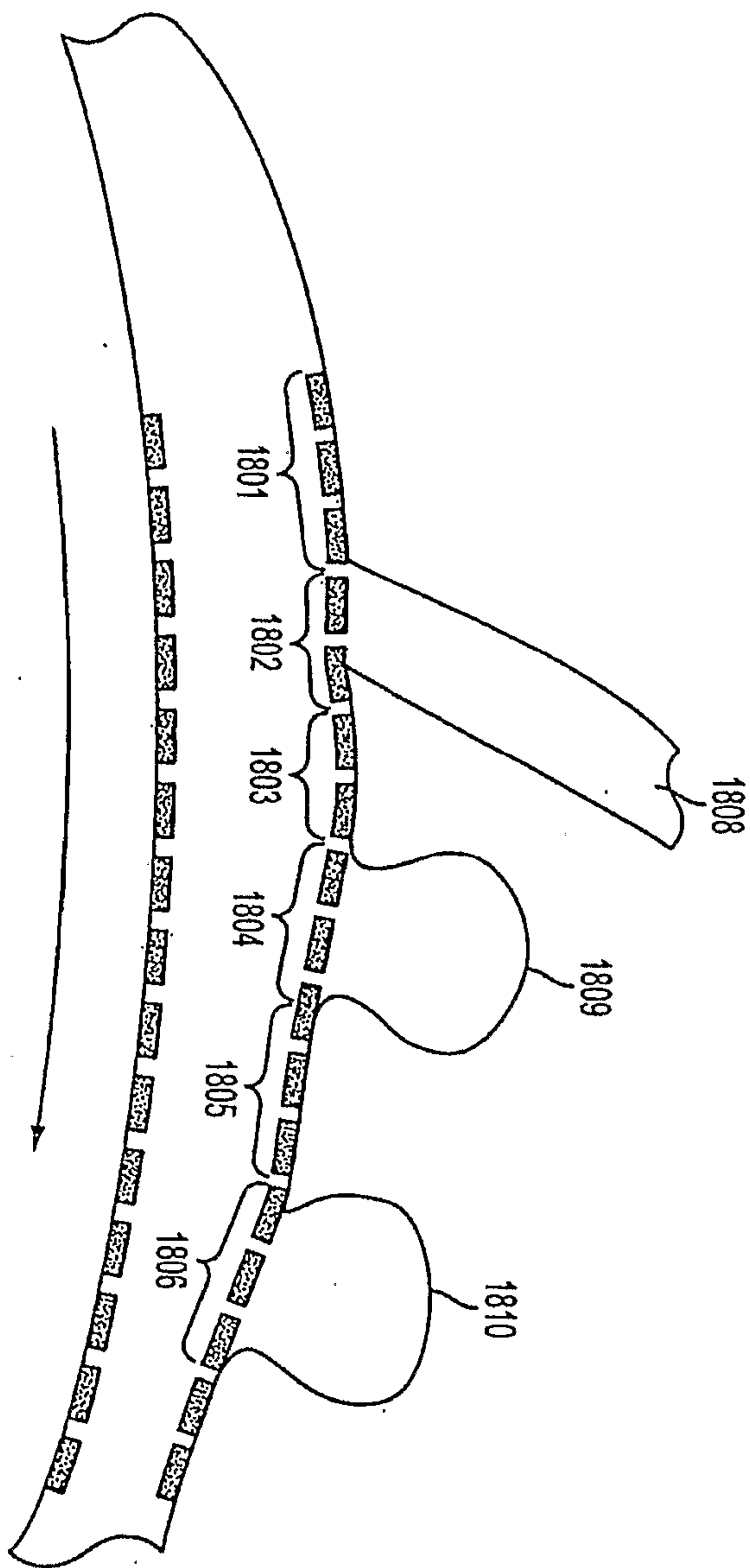

FIG. 18

