

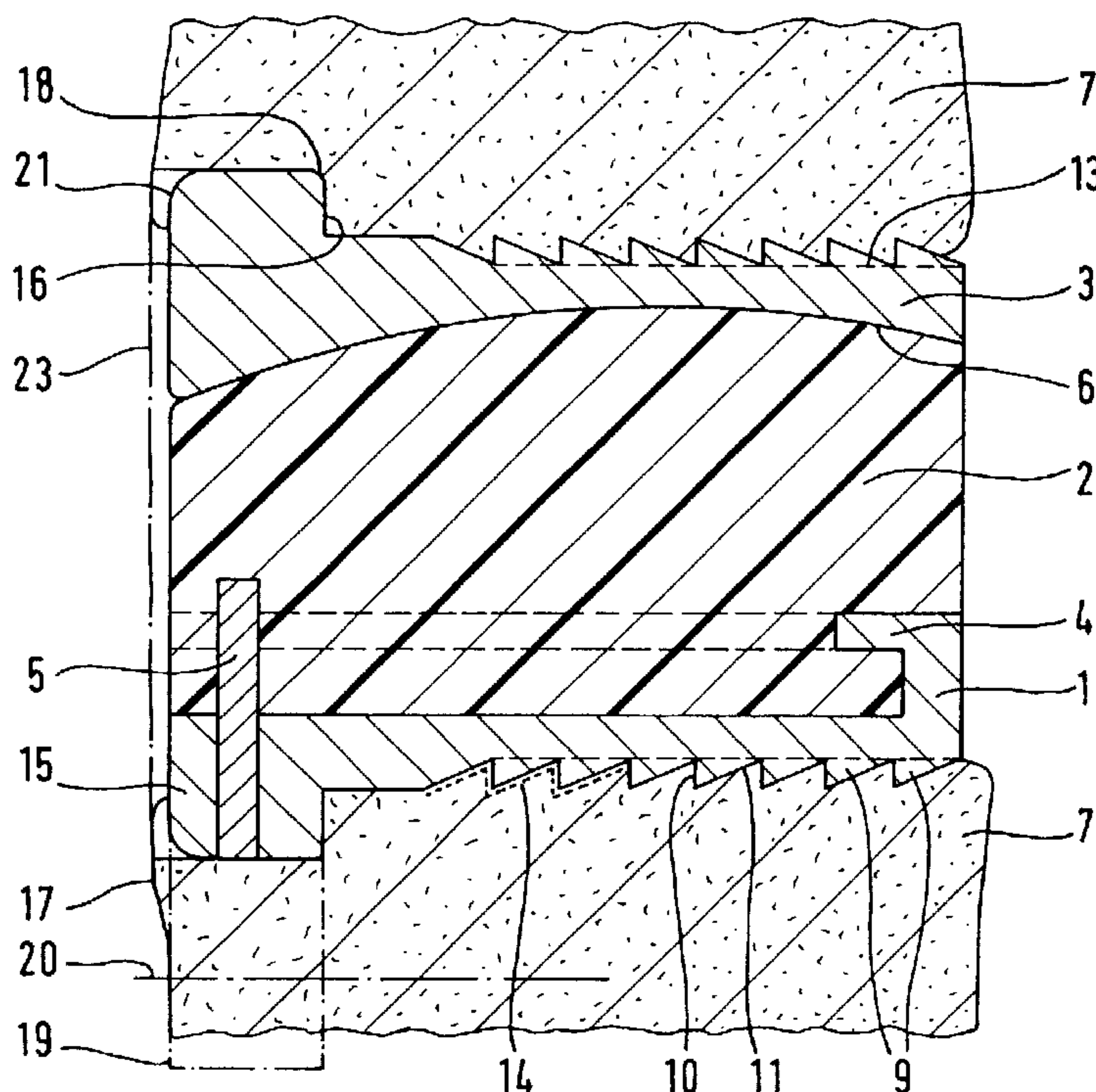

(86) Date de dépôt PCT/PCT Filing Date: 2003/02/21
 (87) Date publication PCT/PCT Publication Date: 2003/09/18
 (85) Entrée phase nationale/National Entry: 2004/08/16
 (86) N° demande PCT/PCT Application No.: EP 2003/001803
 (87) N° publication PCT/PCT Publication No.: 2003/075804
 (30) Priorités/Priorities: 2002/03/12 (02005631.3) EP;
 2003/01/23 (10/349,183) US

(51) Cl.Int.⁷/Int.Cl.⁷ A61F 2/44
 (71) Demandeur/Applicant:
 CERVITECH, INC., US
 (72) Inventeurs/Inventors:
 KELLER, ARNOLD, DE;
 MCAFEE, PAUL C., US
 (74) Agent: MARKS & CLERK

(54) Titre : PROTHESE INTERVERTEBRALE CERVICALE
 (54) Title: CERVICAL INTERVERTEBRAL PROSTHESIS



(57) Abrégé/Abstract:

The invention relates to a cervical intervertebral prosthesis comprising two covering plates that are to be connected to each one of the adjacent vertebral bodies. At least one of both covering plates (1, 3) is provided with a toothing (9), which faces the vertebral body (7) and whose teeth have a steep ventrally facing flank (10) and a less steep dorsally facing flank (11). When the prosthesis is subjected to sufficient compression between its adjacent vertebral bodies, the combination of the saw tooth-shaped toothing with the stop surface is adequate for securely holding the prosthesis in the desired position. This makes it possible, in many cases, to forgo an additional fixing using screws. The flange (15) provided with the stop surface (16) is effectively shortened whereby enabling it to be accommodated inside a recess of the bone (7), and the prosthesis does not ventrally protrude beyond the ventral flush surface of the adjacent vertebral bodies (7).

Abstract

Cervical intervertebral prosthesis with two cover plates which are to be connected in each case to one of the adjacent vertebral bodies. At least one of the two cover plates (1, 3) has a tothing (9) which faces toward the vertebral body (7) and whose teeth have a steep, ventrally directed flank (10) and a less steep, dorsally directed flank (11). When the prosthesis is fitted with sufficient pressing between its adjacent vertebral bodies, the combination of the serrated tothing and the abutment surface is sufficient to hold the prosthesis securely in the desired position. In many cases this makes it possible to dispense with additional screw fixation. The flange (15) carrying the abutment surface (16) is in this case expediently shortened so that it can be accommodated in a recess of the bone (7) and the prosthesis does not protrude ventrally beyond the ventral alignment surface of the adjacent vertebral bodies (7).

Waldemar Link (GmbH & Co.), Hamburg

LIN0739PUS

D/sq

Cervical intervertebral prosthesis

In the cervical region of the vertebral column, there is only a small amount of space available for receiving
5 intervertebral prostheses. Even a slight shifting of prosthesis parts in the dorsal direction can affect the nerves of the spinal cord. Secure fixation of the prostheses is therefore of great importance. In the case of intervertebral prostheses for the lumbar region
10 of the vertebral column, it is known for the cover plates of the prosthesis which face the adjacent vertebral bodies to be provided with ribs or projections which engage in prepared grooves in the vertebral bodies or are designed to be sharp and self-
15 cutting. This is made possible by the fact that the vertebral bodies of the lumbar vertebral column are relatively large and high, so that there is enough space available for fixation devices of this kind. This also applies to fixation flanges which are provided at
20 the ventral edge of the cover plates of the prostheses in order to receive bone screws for securing the cover plates on the associated vertebral bodies. The smallness and low height of the vertebral bodies in the cervical region often rules out the use of these
25 fixation devices or means that said fixation devices appear unsatisfactory. This is all the more so given that ventrally protruding parts of the prostheses have to be avoided, because these can lead to irritation of the esophagus lying immediately in front of them.

30

It is therefore an object of the invention to make available a cervical intervertebral prosthesis with small fixation members which take account of the confined spatial conditions and which nevertheless
35 afford sufficient safety.

The solution according to the invention lies in the

- 2 -

features of the claims. The basic concept involves the use of two fixation means acting against one another, namely, on the one hand, a serrated tothing which cooperates with the bone and which prevents a ventrally directed relative movement of the prosthesis and promotes a dorsally directed relative movement, while, on the other hand, an abutment definitively limits the dorsally directed relative movement.

10 According to Claim 1, at least one of the two cover plates belonging to the prosthesis is provided, on its surface cooperating with the associated vertebral body, with a tothing comprising at least one tooth with a steep, ventrally directed flank and a less steep, dorsally directed flank. This is generally referred to as a serration. The effect of these serrations is that, in the event of a relative movement between the cover plate and the associated vertebral body, a force is exerted on the vertebral body which tends to push it in the dorsal direction. The serrations thus secure against undesired shifting of the cover plate and of the prosthesis in the ventral direction. A multiplicity of such teeth are preferably provided in the tothing. The teeth expediently extend like ribs transversely with respect to the sagittal direction. The tothing should cover substantially the whole surface. At least it should cover approximately half of the available surface directed toward the vertebral body. The teeth must be high enough to be able to exert a sufficient effect. On the other hand, they should be as low as possible in order to take up only a small vertical space. It has proven advantageous if they have a height of between 0.2 and 0.6 mm and if their spacing in the sagittal direction is between 0.5 and 2 mm.

35

The dorsally directed force which the tothing exerts on the cover plate is effective only upon relative movement between the cover plate and the associated vertebral body. Such a relative movement is

- 3 -

undesirable, because in normal circumstances one obviously expects absolute immobilization between the cover plate and the associated vertebral body. In fact, the teeth, which can be regarded as a macroscopic roughening, normally contribute to maintaining the immobilized state between the cover plate and the associated vertebral body. This can be further promoted by providing the prosthesis surface with a coating which promotes intimate connection between bone and prosthesis surface, for example with a microporous and/or bioactive material promoting bone growth.

The force which the tothing exerts in the dorsal direction on the cover plate in the event of a relative movement is neutralized by an abutment surface which is provided at the ventral edge of the cover plate in order to cooperate with the ventral margin of the associated vertebral body. The effect of this abutment surface is that the cover plate, and thus also the prosthesis, can be moved in the dorsal direction by the force of the serrations only until the abutment surface of the cover plate bears against the ventral margin of the vertebral body. The dimensions are chosen such that the desired position of the prosthesis is reached exactly when the abutment surface bears against the ventral margin of the vertebral body.

The abutment surface is expediently formed by a flange which is arranged symmetrically at the ventral edge of the cover plate across a width which is expediently at least as great as half the mediolateral dimension of the cover plate. The result of this is that a parallel bearing of the flange on the ventral margin of the vertebral body is obtained at all times, and an inclined position of the desired sagittal axis of the prosthesis in relation to the sagittal direction of the vertebral body is ruled out.

The flange can be provided with openings for receiving

- 4 -

fixation members, for example bone screws. However, in most cases this is not necessary. A design in which there are no such screw holes and in which the flange has a smaller height in order to be able only to exert its abutment function can even be particularly advantageous. This is because it affords the possibility of forming a recess in the vertebral body, which recess receives the flange. The result of this is that the prosthesis can be pushed so far dorsally in relation to the ventral alignment surface of the adjacent vertebral bodies that it cannot cause irritation of the esophagus or of any nerves or vessels extending there. The prosthesis can even remain completely behind this alignment surface and, viewed from the ventral direction, can thus be anchored completely in the area of the vertebral bodies. Doing without the screw holes also has the advantage that the flange can be given such a low height that the implant becomes very small and can be implanted through a narrow access channel, for example of an endoscope.

If the serrations are designed as ribs extending transversely in relation to the sagittal direction, there is a possibility of the cover plate shifting relative to the associated vertebral body in the direction of these ribs. This can be avoided by providing grooves or ribs which extend transversely in relation to the direction of the tooth ribs. The grooves permit ingrowth of bone substance and thereby prevent the undesired transverse movement. Any ribs provided are expediently self-cutting so that they penetrate into the surface of the vertebral body as the prosthesis is inserted.

The abutment surface does not necessarily have to be formed by a flange. Instead, projections oriented transversely in relation to the plane of the cover plates in many cases suffice. These projections should be arranged symmetrically in a pair in order to permit

- 5 -

an orientation of the prosthesis coincident with the direction of the vertebral bodies. Forming the abutment surface on a pair of symmetrically arranged projections spaced apart from one another has the advantage that
5 the ventral center area of the vertebral bodies, which in principle is expected to be in proximity to the esophagus, is free from prosthesis parts.

All the ventral margins and edges of the prosthesis
10 should be well rounded-off in order to minimize their potential for possible irritation of adjacent organs.

The invention is explained in more detail below with reference to the in the drawing which depicts an
15 advantageous illustrative embodiments. In the drawing:

Fig. 1 shows a plan view of the upper end plate of a prosthesis to approximately true scale,

20 Fig. 2 shows the same on an enlarged scale, and

Fig. 3 shows a sagittal section in the scale corresponding to Fig. 2.

25 The prosthesis comprises a lower cover plate 1 of hard, resistant material, in particular metal, a prosthesis core 2 made of polyethylene or other plastic which has good sliding properties, and an upper cover plate 3 which is made of the same material as the lower cover
30 plate 1. The prosthesis core 2 is connected to the lower cover plate 1 firmly, albeit also detachably. The connection is effected by undercut ledges 4 on the dorsal side and both lateral sides of the lower cover plate 1, into which the prosthesis core 2 provided with
35 complementary grooves can be pushed. In the pushed-in position, it is secured by a bolt 5. The prosthesis core 2 and the upper cover plate 3 form interacting, complementary, preferably spherical slide surfaces 6.

- 6 -

Those surfaces of the cover plates 1 and 3 each facing the associated vertebral body 7 are designed the same. The greater part of their surface is covered by a multiplicity of teeth 9 which are of serrated design, namely with a steep flank 10 directed toward the ventral side, and with a less steep flank 11 directed toward the dorsal side. The steep flank is preferably approximately perpendicular to the plane of extent of the cover plates.

10

The teeth 9 are in the form of ribs which extend transversely in relation to the sagittal mid-axis 8 and which are interrupted in the middle to form a groove 12. The teeth 9 are absent in the area of the groove 12. In the example shown, the bottom surface 13 of the groove coincides with the bottom surface of the teeth and is indicated by a broken line in Fig. 3. However, the groove can also be deeper or shallower. Instead of a centrally arranged groove, a plurality of possibly narrower grooves can also be provided, distributed across the surface. A symmetrical arrangement is recommended. After insertion of the prosthesis, and in cooperation with the adjacent bone substance, the lateral end faces of the teeth 9 directed toward the groove generate a resistance to lateral shifting of the prosthesis relative to the bone. This resistance increases, during further use, as a result of the bone substance growing into the groove 12.

Instead of by a groove, this effect can also be generated by one or more ribs which extend transversely in relation to the extent of the ribs forming the teeth 9. These ribs should be narrow and sharp so that, upon insertion of the prosthesis, they can easily penetrate into the bone substance and do not impede the immediate production of a tight fit of the cover plate surface on the respectively associated bone surface.

To promote an intimate contact between prosthesis

- 7 -

surface and bone surface, the prosthesis surface can be provided with a coating 14 into whose pores the bone substance grows and/or which biologically promotes the incorporation of bone substance.

5

At the ventral edge, the cover plates 1, 3 are provided with a ridge-like projection 15 which protrudes in the cranial direction or caudal direction beyond the surface carrying the teeth 9. Because of its mostly planar extent, the projection is also referred to as a flange. For the sake of simplicity, this expression is also used when the projection has only a low height, as can be seen in Fig. 3. Upon implantation, this flange can be positioned such that its dorsally directed abutment surface 16 lies in front of the ventral limit surface 17 of the associated vertebral body 7. However, since, depending on the anatomical circumstances, such an arrangement may entail prosthesis parts protruding ventrally beyond the alignment face 23 of the adjoining vertebral bodies and there causing irritation of the esophagus or other organs, an operating technique is preferred in which the flange 15 (as is shown in Fig. 3) is recessed into the bone. In other words, a small amount of material is worked away at the ventral margin of the vertebral body so that a recess is formed whose shape and size match that of the flange 15 and which receives the flange after implantation. The abutment surface 16 of the flange then lies against the ventral end face of the this recess. In order to permit a tight bearing of the abutment surface 16 on this end face, the edge 18 of the flange can be rounded. So that the bone is not weakened too much, this requires that the flange has only a low height above the surface carrying the teeth 9. This height should be of the order of 0.5 to 2 mm, preferably between 0.8 and 1.3 mm. Expressed in fractions of the maximum dimension of the implant in the anteroposterior direction (AP direction), this means preferably 0.5 to 2 tenths.

35

- 8 -

The low height of the flange has the advantage that the size of the implant is greatly reduced compared to those embodiments in which the flange is provided with fixation members (e.g. screw holes). The reduced dimensions permit implantation through a surgical opening or an insertion channel of correspondingly reduced diameter, for example in endoscopic implantation.

10 The prosthesis according to the invention affords a very secure fit, in which the serrated teeth, which cause a dorsal "feed direction", prevent unwanted shifting in the ventral direction, while the flange limits the dorsally directed movement of the
15 prosthesis. The position chosen at the time of implantation, in which the abutment surface 16 of the flange 15 bears against a corresponding ventral face of the associated vertebral body, or of the recess formed therein, is thus maintained.

20

The safety of the prosthesis fit obtained by the teeth 9 depends on the prosthesis being fitted with sufficient pressing between the adjacent vertebral bodies. This pressing is generally sufficient if the
25 posterior longitudinal ligament is retained. If this is not possible, the physician will prefer additional securing with bone screws. For this purpose, a design is provided in which the flanges 15 have a greater height, as is indicated by the dot-and-dash line 19,
30 and contain screw holes which serve to receive a bone screw 20, indicated by dot-and-dash lines. This design may also be recommended if the operating surgeon doubts whether the bone quality is sufficient for securely anchoring the prosthesis solely by means of a press fit
35 and the teeth 9. If the version with the higher flanges is chosen, the physician will generally dispense with embedding this flange in the vertebral body by means of a recess formed in the latter, because the vertebral body could be weakened too much by doing this. Instead,

- 9 -

the prosthesis in this case is generally fitted so that the flange comes to lie in front of the ventral face of the vertebra.

5 In order in each case to avoid or minimize any irritation of adjacent organs, all the edges possibly protruding ventrally beyond the alignment face of the adjacent vertebral bodies are rounded, as can be seen for example at the edge 21.

10

The tothing 9 of the prosthesis should be so fine that the prosthesis reaches its final position relative to the adjacent vertebral bodies immediately after implantation. In other words, a situation is to be
15 avoided in which at a later stage, during the pressing which takes place between the adjacent vertebral bodies, the teeth sink to a more than negligible extent with the teeth into the vertebral bodies. This would in fact be associated with an undesired reduction
20 of the cross section of the nerve passages between the vertebrae. In this respect, a height of the teeth of between 0.2 and 0.6 mm, preferably between 0.3 and 0.5 mm, and a spacing of the tooth tips of 0.4 to 2 mm, preferably 0.6 to 1.3 mm, have proven useful.

25

The ventral abutment surface 16 does not have to extend fully across the width of the prosthesis. Instead, it can also be made up of separate, spaced-apart projections expediently arranged symmetrically. Two
30 such projections 22 are indicated in Fig. 1. If a flange-shaped abutment surface 16 is provided, the latter is expediently shaped concavely to match the ventral border of the vertebral bodies, as can be seen in Fig. 2. If the flange has no screw holes and is
35 correspondingly shortened in order to be incorporated into a recess of the vertebral body, a rectilinear abutment surface 16 may however also be expedient, because the end face of the recess cooperating with it can be shaped in any desired way, and a rectilinear

- 10 -

formation is particularly simple.

Patent claims

1. Cervical intervertebral prosthesis with two cover
5 plates (1, 3) which are to be connected in each
case to an adjacent vertebral body (7),
characterized in that at least one of the two
cover plates (1, 3) has a tothing (9) which faces
10 toward the vertebral body (7) and which has at
least one tooth (9) with a steep, ventrally
directed flank (10) and a less steep, dorsally
directed flank (11), and in that the cover plate
(1, 3) has, at its ventral edge, a dorsally
15 directed abutment surface (16) for cooperating
with a ventral surface of the vertebral body (7).
2. Intervertebral prosthesis according to Claim 1,
characterized in that both cover plates (1, 3)
20 have the stated tothing (9) and abutment surface
(16).
3. Intervertebral prosthesis according to Claim 1,
characterized in that the tothing consists of a
multiplicity of teeth (9) with a serrated form,
25 and at least half of the surface directed toward
the vertebral body (7) is covered by the tothing.
4. Intervertebral prosthesis according to Claim 3,
characterized in that substantially the whole of
30 the surface directed toward the vertebral body (7)
is covered by the tothing (9).
5. Intervertebral prosthesis according to Claim 3,
characterized in that the tooth height is between
35 0.2 and 0.8 mm.
6. Intervertebral prosthesis according to Claim 5,
characterized in that the tooth spacing is between
0.4 and 2 mm.

- 12 -

7. Intervertebral prosthesis according to Claim 3 or 4, characterized in that the teeth (9) of the tothing extend substantially transversely with respect to the sagittal direction (8).
8. Intervertebral prosthesis according to Claim 7, characterized in that the surface directed toward the vertebral body (7) has groves (12) and/or ribs which extend transversely with respect to the teeth of the tothing.
9. Intervertebral prosthesis according to Claim 3, characterized in that the teeth are provided with a coating (14) which is porous and/or promotes bone growth.
10. Intervertebral prosthesis according to Claim 1 or 2, characterized in that the abutment surface (16) is formed by a ventral flange (15) of the cover plate (1, 3).
11. Intervertebral prosthesis according to Claim 10, characterized in that the flange (15, 19) has screw holes.
12. Intervertebral prosthesis according to Claim 10, characterized in that the flange (15) has no screw holes.
13. Intervertebral prosthesis according to Claim 10, characterized in that the height of the flange (15) above the surface (13) carrying the tothing is 0.5 to 2 mm.
14. Intervertebral prosthesis according to Claim 10, characterized in that the height of the flange (15) above the surface (13) carrying the tothing (9) is not greater than a fifth of the AP

- 13 -

dimension of the cover plate.

- 5 15. Intervertebral prosthesis according to Claim 10, characterized in that the flange (15) extends across a width of at least half the width of the cover plate.
- 10 16. Intervertebral prosthesis according to Claim 1 or 2, characterized in that the abutment surface (16) is formed by two projections (22) spaced apart from one another and symmetrical with respect to the sagittal center axis (8) of the cover plate (1, 3).
- 15 17. Intervertebral prosthesis according to Claim 1 or 2, characterized in that the ventral edges are rounded.
- 20 18. Method for inserting a cervical intervertebral prosthesis which has at least one cover plate (1, 3) provided with a tothing (9) and with a ventral abutment surface (16) facing in the dorsal direction, in which method, before the intervertebral prosthesis is inserted, the vertebral body (7) with which this cover plate (1, 3) cooperates is provided at the ventral margin with a recess for receiving that part (15) of the cover plate (1, 3) carrying the abutment surface (16).
- 25 30 19. Method according to Claim 14, characterized in that the depth of the recess in the AP direction is dimensioned such that no part of the prosthesis protrudes appreciably beyond the ventral alignment surface of the adjacent vertebral bodies (7) toward the esophagus.
- 35 20. Method according to Claim 14, characterized in that it is performed endoscopically.

Fig. 2

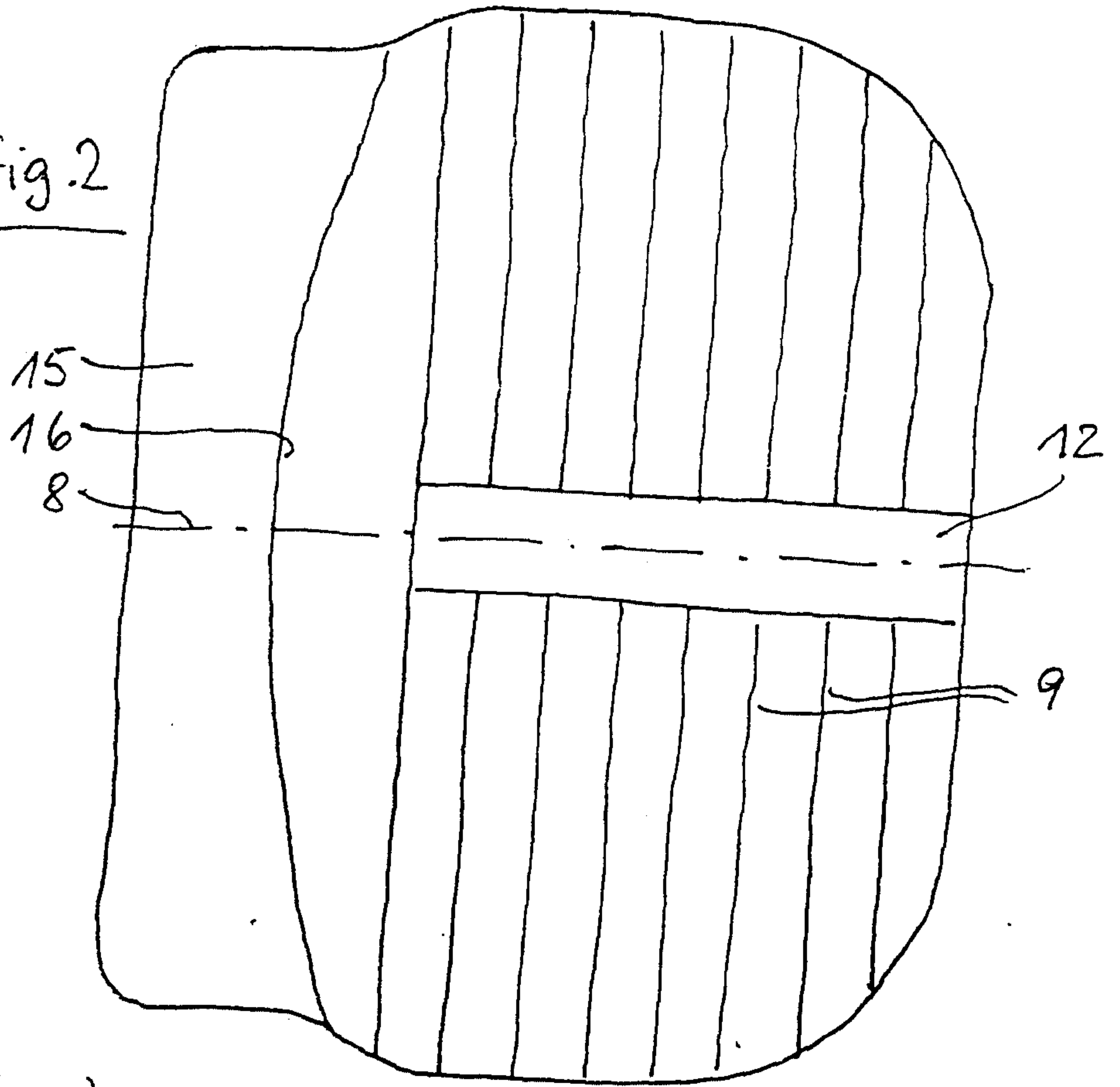

Fig. 1

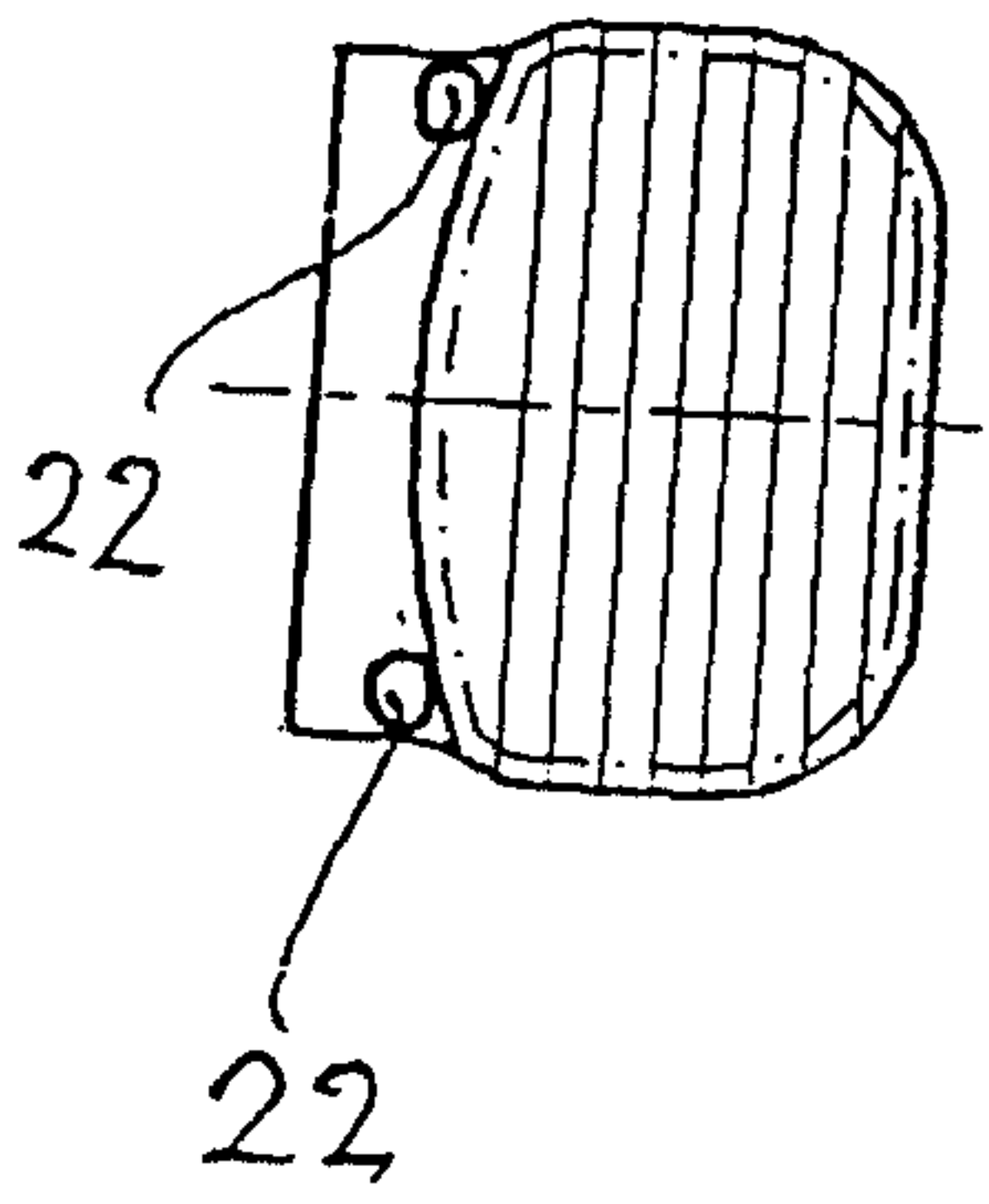

Fig. 3

