

Jan. 12, 1937.

R. H. LAWSON ET AL

2,067,877

KNITTING MACHINE

Filed Jan. 10, 1934

7 Sheets-Sheet 1

FIG. 1.

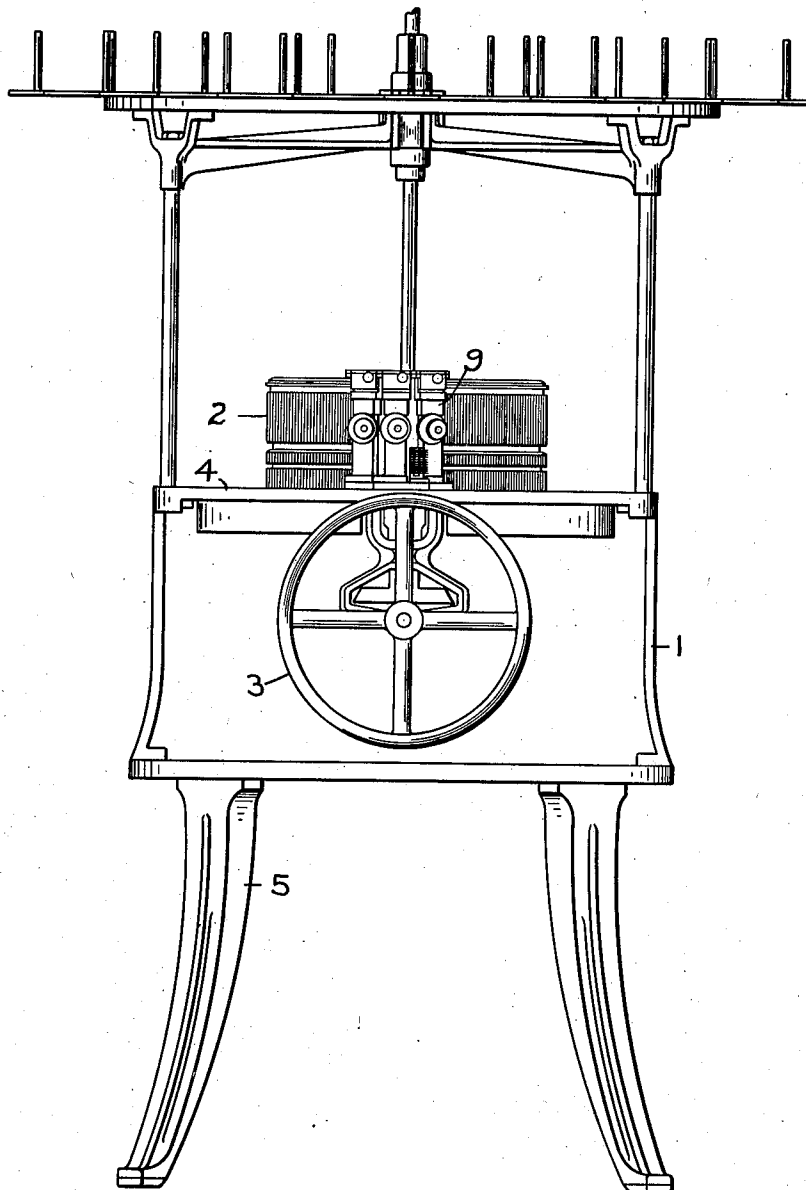

INVENTORS:
ROBERT H. LAWSON,
WILLIAM L. SMITH JR.,
By Roy F. Lovell,
ATT'Y.

Jan. 12, 1937.

R. H. LAWSON ET AL

2,067,877

KNITTING MACHINE

Filed Jan. 10, 1934

7 Sheets-Sheet 2

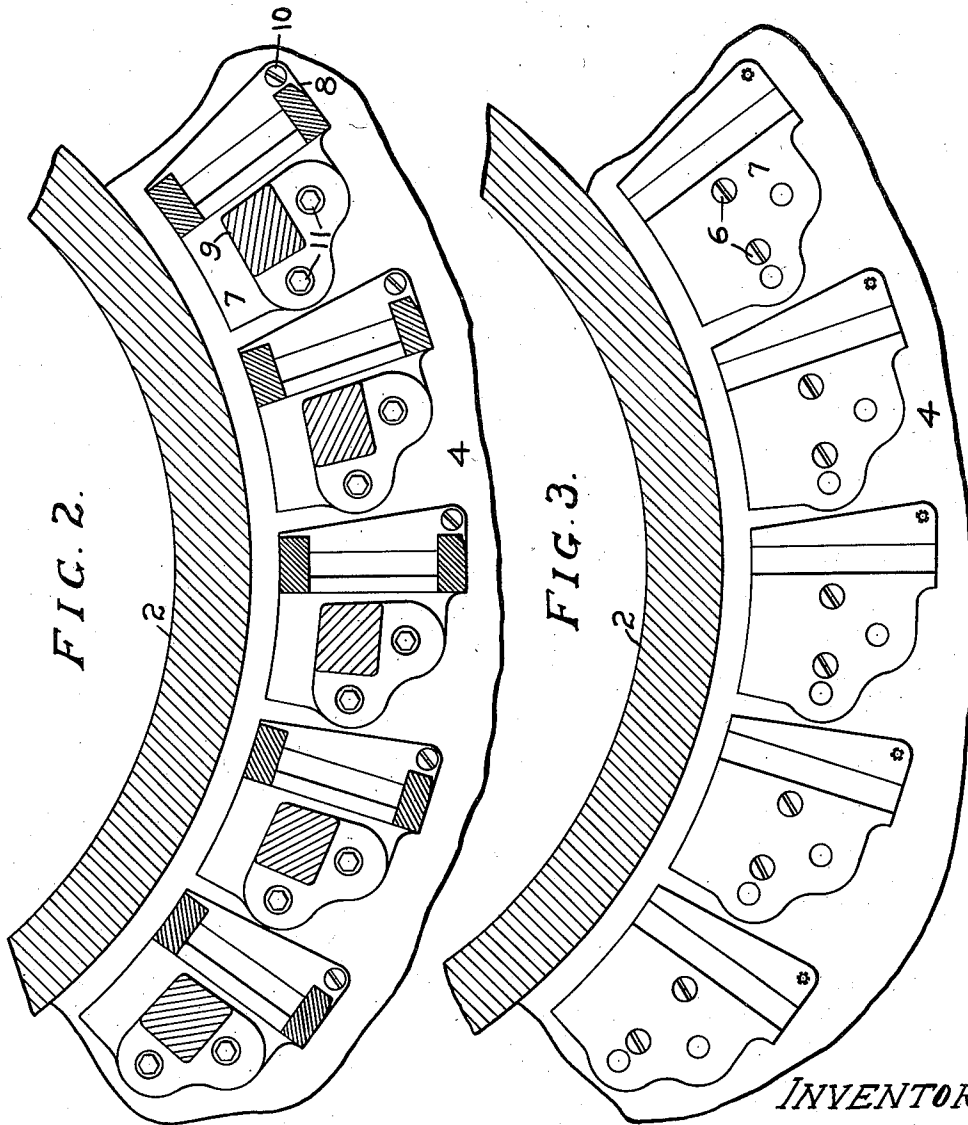

INVENTORS:
ROBERT H. LAWSON,
WILLIAM L. SMITH JR.,
BY Roy K. Lovell,
ATT'Y.

Jan. 12, 1937.

R. H. LAWSON ET AL

2,067,877

KNITTING MACHINE

Filed Jan. 10, 1934

7 Sheets-Sheet 3

FIG. 4.

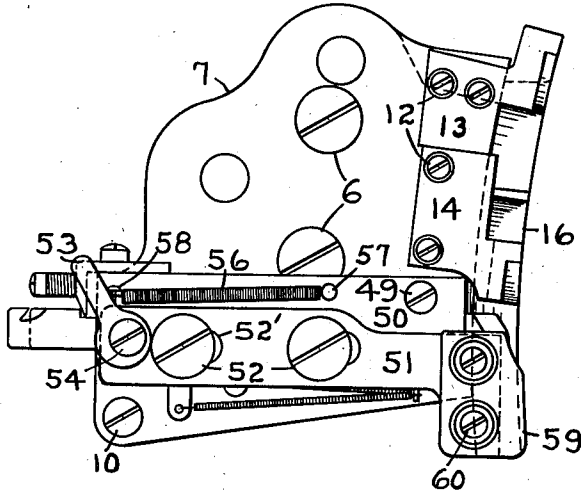

FIG. 7.

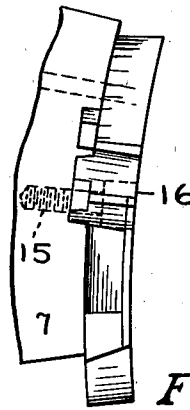

FIG. 8.

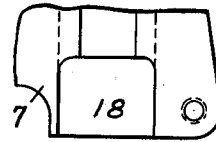

FIG. 5.

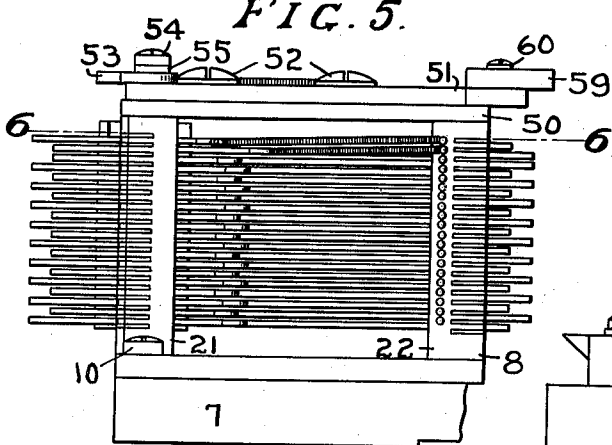

FIG. 9.

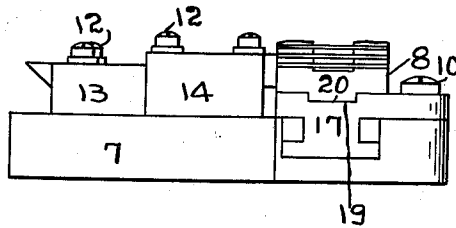

FIG. 6.

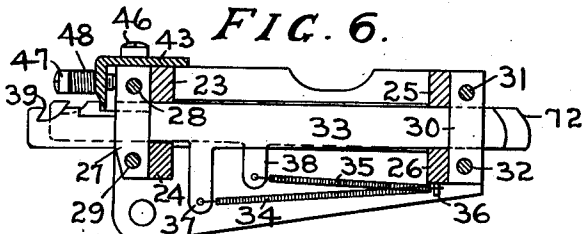
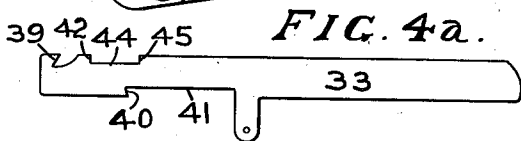

FIG. 4a.



INVENTORS:
ROBERT H. LAWSON,
WILLIAM L. SMITH JR.,
BY Roy K. Lovell,
ATTY.

Jan. 12, 1937.

R. H. LAWSON ET AL

2,067,877

KNITTING MACHINE

Filed Jan. 10, 1934

7 Sheets-Sheet 4

FIG. 10.

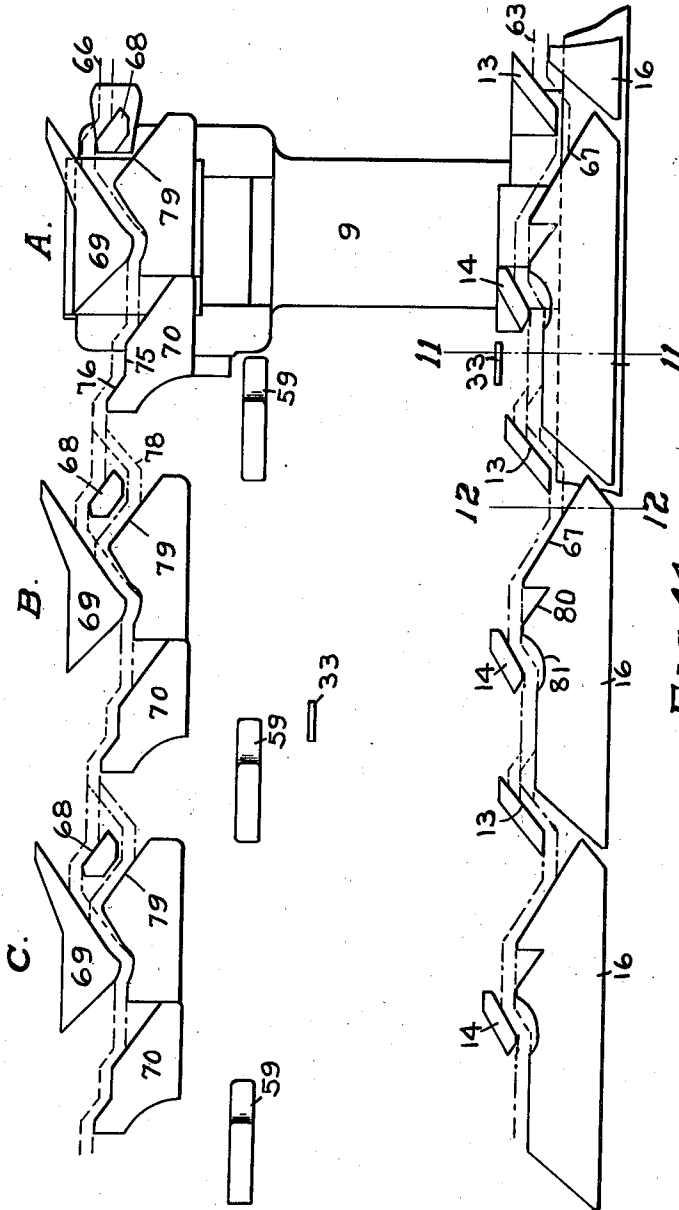

FIG. 12. FIG. 11.

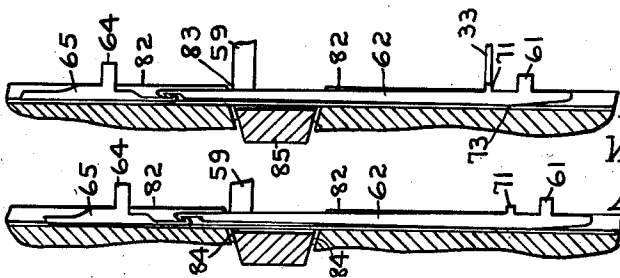
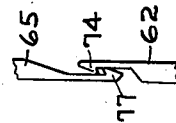

FIG. 11a.



INVENTORS:
 ROBERT H. LAWSON,
 WILLIAM L. SMITH JR.,
 BY Roy F. Lovell
 ATT'Y.

Jan. 12, 1937.

R. H. LAWSON ET AL

2,067,877

KNITTING MACHINE

Filed Jan. 10, 1934

7 Sheets-Sheet 5

FIG. 13.

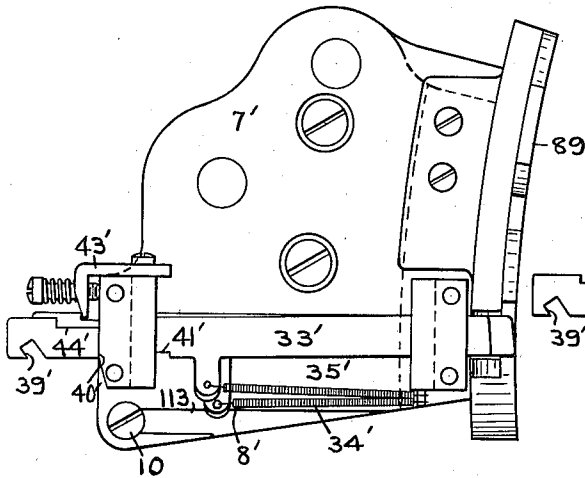

FIG. 13a.

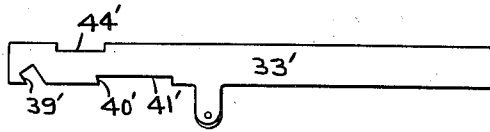
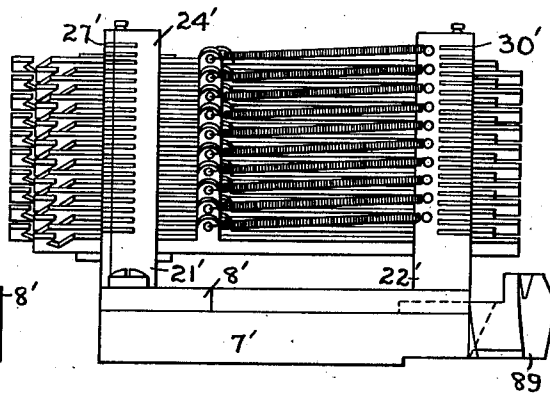
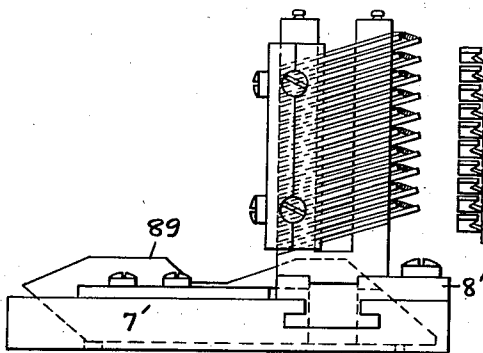

FIG. 14.

FIG. 15.



INVENTORS:
ROBERT H. LAWSON,
WILLIAM L. SMITH, JR.,
BY Roy F. Lovell,
ATT'Y.

Jan. 12, 1937.

R. H. LAWSON ET AL

2,067,877

KNITTING MACHINE

Filed Jan. 10, 1934

7 Sheets-Sheet 6

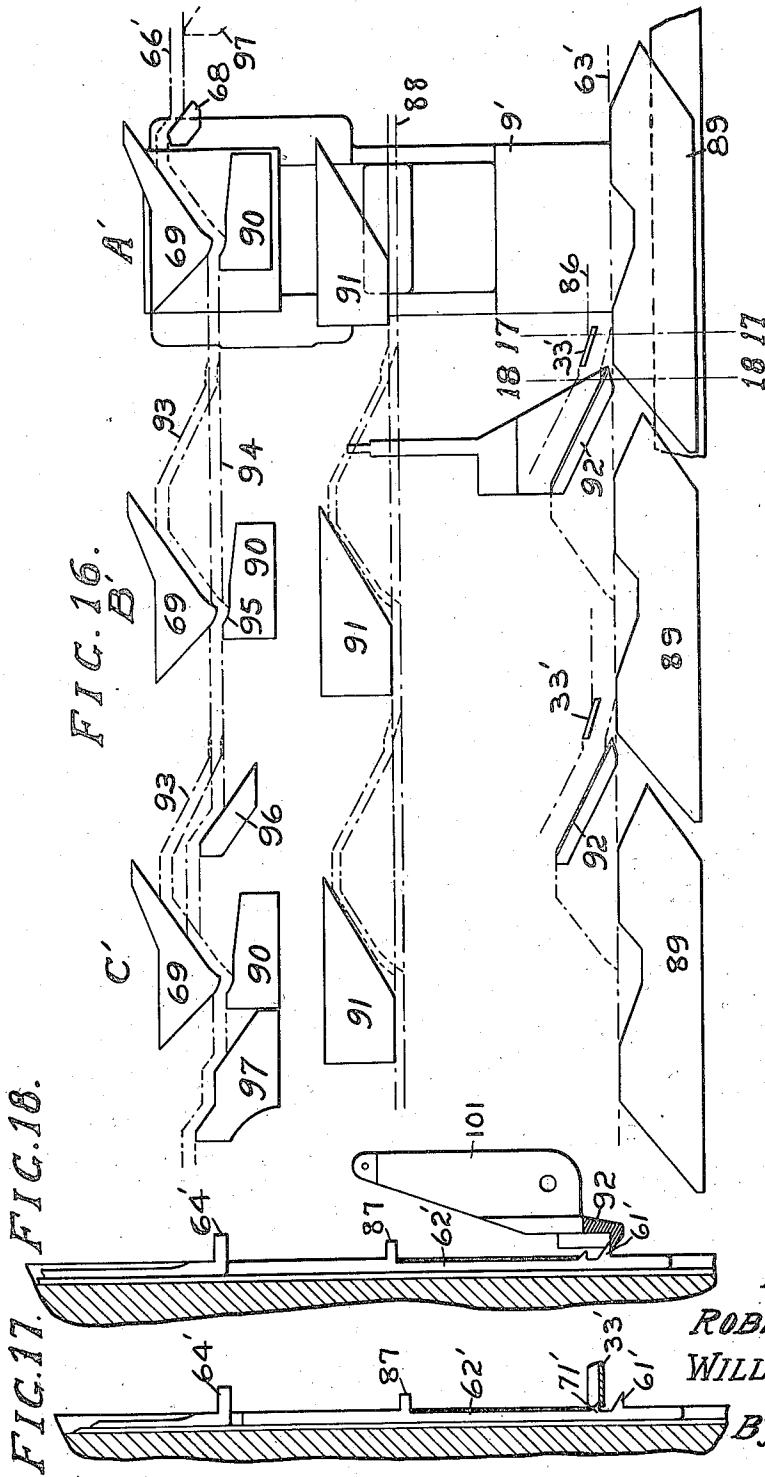

INVENTORS:
ROBERT H. LAWSON,
WILLIAM L. SMITH JR.,
By Roy J. Lovell
ATT'Y.

Jan. 12, 1937.

R. H. LAWSON ET AL

2,067,877

KNITTING MACHINE

Filed Jan. 10, 1934

7 Sheets-Sheet 7

FIG. 19.

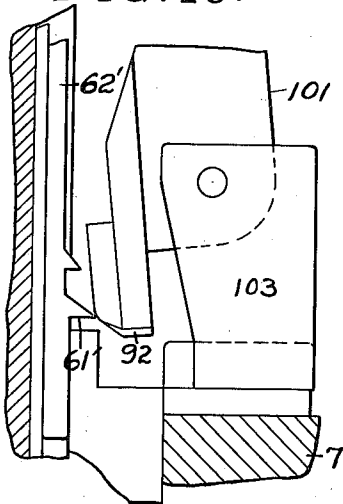

FIG. 22.

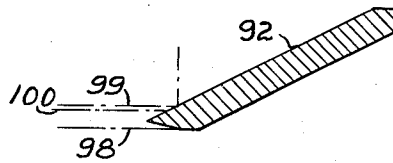

FIG. 24

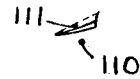

FIG. 23.

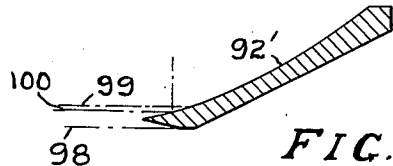

FIG. 20.

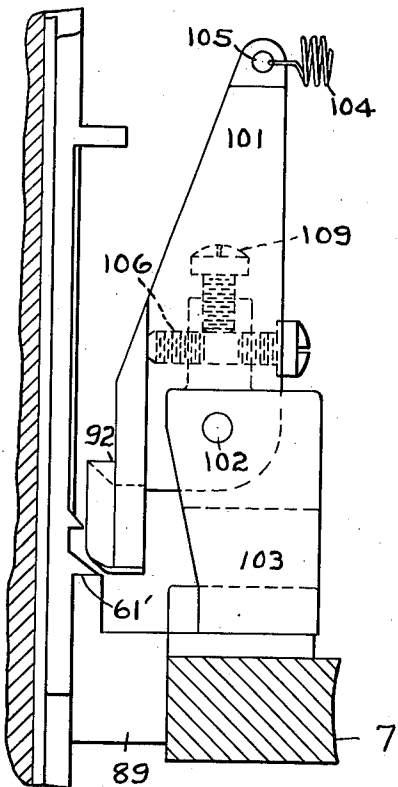
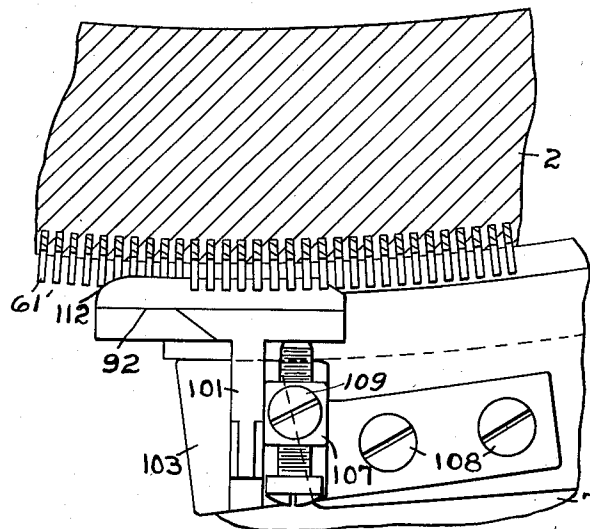

FIG. 21.



INVENTORS:
ROBERT H. LAWSON,
WILLIAM L. SMITH JR.,
By Roy F. Lovell
ATT'Y.

UNITED STATES PATENT OFFICE

2,067,877

KNITTING MACHINE

Robert H. Lawson and William L. Smith, Jr.,
Pawtucket, R. I., assignors to Hemphill Com-
pany, Central Falls, R. I., a corporation of
Massachusetts

Application January 10, 1934, Serial No. 706,082

18 Claims. (Cl. 66—50)

This invention relates to improvements in knitting machines and more especially to knitting machines having a plurality of feeding stations at each of which is a set of knitting cams.

In the drawings:

Fig. 1 is a view in elevation showing a knitting machine to which the improvements are applied;

Fig. 2 is a fragmentary plan view partly in section showing plates upon which are mounted cams for controlling jacks as well as plungers or cams for selecting the same, and cam blocks which carry the needle and sinker jack controlling cams;

Fig. 3 is a view similar to Fig. 2 but showing the plates before the plunger and cam brackets have been mounted thereon;

Fig. 4 is a plan view of one of the plates shown in Figs. 2 and 3 upon which plate is mounted the cams for controlling the movements of the jacks, and plungers for selecting the same;

Fig. 4a is a detail view of a jack selecting plunger;

Fig. 5 is an elevational view of the bracket and plungers therein shown in Fig. 4;

Fig. 6 is a view in section taken along the line 6—6, Fig. 5;

Fig. 7 is a fragmentary view, similar to Fig. 4, but showing only the jack raising cam;

Fig. 8 is a detail fragmentary view of a portion of one of the plates;

Fig. 9 is a view in rear elevation taken from the left of Fig. 4;

Fig. 10 is a view in elevation showing the several cams as they would be viewed from the interior of the needle cylinder and showing the cam paths of the butts of the jacks and needles for producing patterned fabric;

Fig. 11 is a view in section showing a needle and jack as they are at the phase of the knitting cycle indicated by the line 11—11, Fig. 10;

Fig. 11a is an enlarged detail view showing inter-engagement of a selected jack and its companion needles, Fig. 11;

Fig. 12 is a view similar to Fig. 11 at a later phase of the knitting cycle indicated by line 12—12, Fig. 10;

Fig. 13 is a plan view similar to Fig. 4 but showing a modification;

Fig. 13a is a detail view of one of the plungers shown in Fig. 13;

Fig. 14 is a view similar to Fig. 9 but of the modification shown in Fig. 13;

Fig. 15 is a view similar to Fig. 5 but of the modification shown in Fig. 13;

Fig. 16 is a view similar to Fig. 10 but showing

the needles and jacks moving in somewhat different paths for the production of another type of patterned fabric;

Fig. 17 is a sectional view showing a needle and associated jack at a certain phase of the knitting cycle, said phase of the knitting cycle being indicated by line 17—17, Fig. 16;

Fig. 18 is a view in section showing the needle and jack at a later phase in the knitting cycle as indicated by the line 18—18, Fig. 16;

Fig. 19 is a relatively enlarged fragmentary view, partly in section, similar to Fig. 18 but showing the jack raising cam in tilted position;

Fig. 20 is a relatively enlarged fragmentary view, partly in section, and similar to Fig. 18;

Fig. 21 is a fragmentary plan view, partly in section, of the parts shown in Fig. 20;

Fig. 22 is a view in section of the jack raising cam, the dotted lines representing different paths of the jack butts;

Fig. 23 is a view similar to Fig. 22 but showing a slightly modified construction of the cam; and

Fig. 24 is a fragmentary view showing the advantages of the cam shown in Fig. 23 as compared with the cam shown in Fig. 22.

The frame 1 of the machine has mounted therein for rotary movements a needle cylinder 2 which may be rotated in any suitable manner by driving mechanism (not shown), and, at times, by a hand wheel 3. Surrounding and supporting the needle cylinder 2 for rotary movements therein is a circular plate or base 4 which is connected to the frame of the machine from which depend legs 5. Mounted upon the upper surface of the base 4 and secured thereto as by screws 6 are a series of equally spaced plates 7. Upon the plates 7 are mounted plunger brackets 8, and other brackets 9 upon which are mounted the cams for controlling the movements of the knitting instrumentalities such as needles and sinkers, the brackets 8 being secured to the plates 7 as by means of a screw 10, and the brackets 9 being secured to the plates 7 as by screws 11. Also mounted on the upper surfaces of the plates 7 (Figs. 4 and 9) and secured thereto as by screws 12 are jack lowering cams 13 and 14 and secured to the forward faces of the said plates 7 as by screws 15 are jack elevating cams 16 (Fig. 7). The plunger carrying bracket 8 each consists of a plate 17 having a dove-tailed sliding connection with its bracket 7 the screw 10 serving to retain the plate 17 in assembled position. It will be noted by inspecting Fig. 8 that the cut-away portion 18 at the outer side of the bracket 7 facilitates assembly

of each plate 17 with its companion plate 7. The plates 17 are each provided with a longitudinal groove 19 within which tenons 20 are seated being fastened to the plate 17 as by screws not shown. The tenons 20 are integral with uprights 21, 22 consisting of spaced arms 23, 24, 25, 26. The arms 23, 24 are horizontally slotted and within the said slots are seated spacers 27 said spacers being retained in the slots as by means of pins 28, 29 which pass through holes in the spacers and arms 23, 24. Likewise spacers 30 are seated within slots provided in the arms 25, 26 being retained in position as by pins 31, 32. A series of flat strip-like elements or plungers 33, twenty being shown, pass between the arms 23, 24 and 25, 26 being separated by the spacers 27 and 30 which support them in a vertical sense. The said plungers 33 are urged to a position adjacent to the needle cylinder 2 as by means of springs 34, 35, the said springs being connected to pins 36 which are secured to and project laterally from arm 26, and also being secured to lugs 37, 38 which are integral with and project laterally from plungers 33. As shown, the springs 34 are longer than the springs 35 being connected to lugs 37 which are longer than the lugs 38 and are spaced a greater distance from the pins 36. The relative spacing of the lugs 37, 38 from the pins 36 and their relative lengths permits the springs 34, 35 to be spaced from one another so that the springs will not interfere with the proper functioning of adjacent springs. As just stated the springs 34, 35 normally retain the plungers 33 adjacent to the needle cylinder and if all of the plungers were in such position there would be no selective action of such plungers on butts of jacks in the manner later to be described; therefore in order to effect the selective control of jacks it is necessary that certain ones of the twenty, more or less, plungers 33 be moved to the relatively retracted position shown by the upper plunger 33, Fig. 6, the selective movement of the plungers being effected by means of a hooked shaped implement (not shown) which is manually operated to engage the hook shaped ends 39 of the plungers to move them to the left, Figs. 5 and 6. When the plungers 33 are selectively retracted as just described, detents or shoulders 40 provided in each of the said plungers by recessing them, engage the outer face of the arm 24 thus temporarily locking the moved plungers in a relatively outward position, i. e., away from the needle cylinder. The springs 34, 35 assist in the locking engagement of the detents 40 of the arm 24 by imparting a slight rocking movement to the plungers which is made possible by recessing the said plungers as at 41. When selected ones of the plungers 33, at the several feeding stations, have been moved to an outward position as just described, they effect the knitting of fabric having a certain pattern by controlling the movements of jacks as will be presently described; and consequently, the said plungers once selected are maintained in such selected position and until it is desired to change the pattern of the fabric at which time, preparatory to arranging the plungers for the knitting of another pattern, all of the said plungers or some only of them may be permitted to move through the action of the springs 34, 35 to their inward position, i. e., adjacent to the needle cylinder. Such return movement of the plungers 33 is most conveniently effected simply by pressing on the edges of the plungers opposite the hooks 39 where-

upon the springs return the plungers to their initial position adjacent to the needle cylinder. Such inward movement of the plungers 33 is limited by engagement of lugs 42 of the plungers 33 with an angle plate 43. It will be noted that the lugs 42 are formed by providing slots or recesses 44 in the plungers 33, such recesses leaving edges 45 which limit the outward movement of the plungers 33 when they are withdrawn by the hooked implements as described. The plate 43 is adjustably secured to the arm 23 by means of pins or screws 46 which pass through elongated slots (not shown) in the plate 43 and into threaded engagement with the arm 23. The plate 43 may be adjusted so as to permit the plungers 33 to move to a position closer to or farther from the needle cylinder as by means of screws 47 which are in threaded engagement with the outer portion of the angle plate 43 and contact with the outer face of the arm 23. In adjusting the said plate 43, the screws 46 are first loosened and then the screws 47 are turned either to the right or to the left as the case may be, a spring 48 serving to lock the screw 47 and prevent turning thereof. When the plate 43 is in properly adjusted position the screws 46 are tightened thus clamping the plate 43 in fixed position with respect to the arm 23.

Mounted upon the upper surface of the arm 25 as by means of a screw 49 and upon the upper surface of the arm 24 by means of a screw (not shown) is a plate 50 upon the upper surface of which is adjustably mounted a cam carrying plate 51. Adjustments of the plate 51 are effected by screws 52 which pass through elongated slots 52' in the plate 51 and into threaded engagement with the plate 50, the said screws 52 serving to hold the plate 51 to the plate 50 when once adjusted. Also mounted upon the upper surface of the plate 51 is a cam lever 53 which is adapted to be rigidly held in an adjusted position as by means of a screw 54 between which and the lever 53 is a washer 55. The plate 51 when not clamped in position with respect to the plate 50 is urged to the right, Figs. 4 and 5, by means of a coil spring 56 is attached at one end to a pin 57 upstanding from the plate 50 and at its other end to a pin 58 laterally projecting from the plate 51. In order to adjust the plate 51 with respect to the plate 50, screw 54 is loosened and the cam lever 53 turned in one direction or the other either permitting the spring 56 to move the plate 51 to the right or by engaging the head of a screw 52 to retract the plate 51 against the tension of the spring 56. In either case when the plate 51 has been moved to a properly adjusted position, the screw 54 is tightened thus locking the cam lever 53 thus effectively clamping the plate 51 to the plate 50. On the outer portion of the plate 51 is affixed a cam 59 as by means of screws 60, the function of which cam 59 will be hereinafter described.

Referring to Figs. 10, 11, 11a and 12, the cams of several adjacent feeding stations are shown as well as the paths of the jack and needle butts. The butts 61 of the jacks 62 travel along a path indicated by the dot and dash line 63 while the butts 64 of the needles 65, which may be latch needles, travel along the path indicated by the dot and dash line 66. For convenience the cams at the three feeding stations are designated by the reference letters A, B and C, the needles, as indicated by the path 66, knitting plain stitches at the feeding station A and ornamental or special stitches such as tuck stitches at the feeding 76

stations B and C. Considering, first, knitting at the feeding station A, the jack butts 61 all move along horizontally for a distance until they engage the lower face of the cam 13 which depresses all of the said jacks 62 after which they are all elevated by the cam face 67 of the cam 16, being raised to their highest position. Thereafter the lower face of the cam 14 again engages the butts 61 and partially depresses the jacks 62. While the jacks move along the path 63, as just described, the needle butts 64 move along the path 66 being first engaged and elevated by a cam 68 which is one of a series of cams carried by the supporting post 9. After being elevated by the cam 68, a second cam 69 engages the butts 64 and depresses the needles 65 to draw their stitches alone or in conjunction with other instrumentalities such as sinkers. After passing the cam 69 the butts 64 move along the path 66 being elevated by a cam 70. The movements of the jack butts along the path 63 and of the needle butts along the path 66 just described are entirely independent of one another, selective inter-engagement of the jacks 62 with their companion needles 65 which is about to be described not having been effected as by the selective plungers 33.

For the purpose of selectively controlling the movements of the needles 65 their companion jacks 62 have a series of frangible butts 71, all of the said jacks originally having as many butts as there are plungers 33. When setting up the machine for a new pattern certain ones of the frangible butts 71 are broken off, the jack 62 shown in Fig. 11 having left thereon a butt 71 at one elevation and the jack 62 shown in Fig. 12 having left thereon butt 71 at a lower elevation. Assuming that a jack 62 such as that shown in Fig. 11 has a butt 71 at a level to be engaged by the plunger 33 immediately at the left of the post 9, Fig. 10, engagement of the said butt 71 by the curved inner face 72 of such plunger causes the said jack 62 to be rocked on its fulcrum 73 which is at or about at the level of the butt 61, thereby causing its upper hook-shaped end 74 to be moved inwardly, i. e., in the direction of the needle cylinder, to the position shown in Figs. 11 and 11a. This rocking movement of the jacks 62 occurs while the butts 64 are moving along the horizontal face of the cam 70 indicated by the numeral 75, and immediately thereafter the cam face 76 of the cam 70 engages the butt 64 and causes the needle 65 to be elevated to the position shown in Fig. 12 thus effecting inter-engagement between the hook-shaped end 74 of the jack 62 and a correspondingly shaped lower end 77 of the companion needle 65. The interengagement of the jack and needle as just described precludes any possibility of the jack and needle separating. When the needles have been elevated by the cam 76 engaging their butts 64, the face of the cam 59 closest to the needle cylinder engages the jacks 62 and retains them at a position adjacent to the needle cylinder while the cam 13 engages the butts 61 of all of the jacks 62 lowering them to their lowermost position as indicated in Fig. 10. The needles which were not moved into inter-engagement with their jacks by the selective action of the plungers 33 are elevated so that their hooked ends 77 move past the hooked ends 74 of their companion jacks 62 before the cam 59 causes all of the jacks 62 to be retained in a position adjacent to the needle cylinder as shown in Figs. 11 and 12. Thus the selective action of the plungers 33 upon

the jacks 62 results in the cam 13 causing the needles companion to the selected jacks to be depressed as indicated by that portion of the path 66 designated by the numeral 78, while the butts of the needles companion to the non-selected jacks move along horizontally until they are engaged and elevated by the cam 68 appertaining to the feeding station B. Continued relative movements of the needle cylinder and cams causes the butts 64 of the selected needles to be engaged and elevated by the leading face of a cam 79. Thereafter all of the needles are lowered by the cam 69 after they have taken another strand of yarn in their hooks. One of the functions of the cam 68 (feeding station B, Fig. 10) is to cause the non-selected needles to clear their latches, if latch needles be used, while the selected needles which are not elevated to latch clearing position by the cam 68 engage a second strand of yarn in their hooks and tuck. After having been lowered by the cam 13 engaging butts 61 the previously selected needles and jacks are elevated by their respective cams 79 and 67 while the said needles and jacks are still inter-engaged; however the cam 67 is somewhat longer than the cam 79 and consequently the additional elevation of the previously selected jacks disengages the hooks 74 from their companion hooks on the needles 75. Consequently after the needles and jacks are lowered by the cams 69 and 14 respectively at the feeding station B they are ready for a new selection by a set of plungers 33 immediately in advance of the cam 14 at feeding station B.

Adjacent to the upper portion of the cam face 67 there is shown a cut-out portion in the cam 16 at 80 which avoids the possibility of a descending, previously non-selected needle striking the upper portion of its companion jack. Ordinarily when the non-selected needles are lowered by a cam 69 the beveled forward faces of the hooks 77 engage adjacent, beveled faces of the hooks 74 and causing them to spring out thus permitting the tails of the needles 65 to move down past the upper ends of their companion jacks 62, but should a jack tend to retain its position adjacent to the needle cylinder for a short interval of time either the tail on the needle or the upper portion of the companion jack or both would break unless some provision such as a recess 80 in the cam 60 were employed, such recess permitting the jacks 62 to move down a short distance after being impacted by the companion and descending needle. Each cam 16 is also provided with a second recess 81 immediately below the cam 14 for the purpose of permitting the jacks to be depressed when the butts 64 of the needles engage the upper, hooked ends 74 of the jacks 62, without bending or breaking them; in other words a provision is made for slight differences in the lengths of jacks or needles.

The selection of jacks and consequently their needles by plungers such as 33 for controlling the knitting at the following feeding station C proceeds in the same manner as hereinbefore described preparatory to knitting at feeding station B. Plungers 33 at each feeding station constitute a series of thin, flat elements which, in their active and inactive positions, are disposed in parallel juxtaposition, e. g., the said plungers are arranged one above another with their flat faces or sides arranged closely adjacent to one another.

As hereinbefore disclosed the plain feeding station A where all of the needles knit is followed

by two feeding stations B and C where special or ornamental stitches are knitted by some of the needles as a result of selective needle control. The needle station C may be followed by one or more stations, knitting tuck, or other fancy stitches, or by a feeding station like A where a plain course is knitted. Furthermore, the special arrangement of the feeding stations shown, i. e., one plain feeding station followed by two feeding stations where special or ornamental stitches are knitted, may be varied as by knitting plain fabric at every other feeding station, or by knitting ornamental courses at one or two feeding stations only.

As shown in Figs. 11 and 12 the needle walls 82 are recessed as at 83 thus permitting the cam 59 to be positioned closely adjacent to the needle cylinder. The walls 82 are beveled as at 84 being firmly retained in position by the wedging action of ring segments 85 which are likewise beveled on their faces contacting with the bevels 84. The segments 85 are connected to the needle cylinder as by screws (not shown).

Referring now to the modification disclosed in Figs. 13-18 inclusive, the plates 7' which are spaced around the needle cylinder as are the plates 7, have mounted thereon posts 9 upon which are mounted cams controlling movements of the needles and other knitting instrumentalities such as sinkers. Also mounted on each plate 7' is a bracket plate 8' and cams 89. Upon bracket plate 8' are mounted uprights 21', 22', each including spaced arms corresponding to the arms 23, 24, 25 and 26, Fig. 6. Between the several arms are received spacers 27', 30' which support for sliding movements plungers 33' which correspond in position and function to the plungers 33.

Although as just described pattern effects are obtained by tuck stitch knitting, this is not the only method of knitting patterned fabrics which can result from the use of the construction hereinbefore described.

The plungers 33' are held in a forward position adjacent to the needle cylinder as by springs 34', 35', being selectively engaged by implements that enter the notches 39' and move the said plungers 33' outwardly and against the tension of the springs 34' 35', the said plungers when moved outwardly being locked in position by detents or shoulders 40' engaging the arm 24' in the same manner as hereinbefore described in connection with the form of the invention shown in Figs. 4, 5 and 6. The inward and outward movements of the plungers 33' are limited by the plate 43' which engages the shoulders at each end of the slot 44'.

The jack selection presently to be described is effected in a manner somewhat different than that hereinbefore described and as a consequence thereof cams similar to the cams 59 are not necessary.

Referring particularly to Figs. 16, 17 and 18 where the cams adjacent to the feeding stations A', B', C' are shown, the path of the jack butts 61' is indicated by the dot and dash lines 63', the path of the needle butts 64' is indicated by the dot and dash line 66', and the path of the selective jack butts 71' is indicated by the single dot and dash line 86. As in the form shown in Figs. 11 and 12, each jack 62' is initially provided with a full complement, say twenty, frangible butts 71', some or all of which are broken off as dictated by the pattern of the fabric to be knitted. The butts 61', 71' are triangular,

their upper edges inclining downwardly and outwardly, thus permitting cams or plungers 33' more readily to enter between closely adjacent butts.

When the jacks 62' have been assembled in accordance with the pattern of the fabric to be knitted, the needles are selected by the plungers 33' which elevate the jacks and consequently their companion needles by selectively engaging the butts 71'.

The relative rotary movements of the cams and needles being such as to cause the needles and jacks to move from the right to the left, Fig. 16, the needle butts 64' travel along the path 66', the jack butts 61' travel along the path 63', the selective butts 71' travel along the path 86, and the upper jack butts 87 travel along a path indicated by the dot and dash line 88. As the cams at the feeding station A' effect the knitting of plain fabric the needles and jacks move along independent paths, the movements of the jacks not affecting the movements of their companion needles. As the needles and jacks leave their respective cams 69, 90 and 89, 91, selectively positioned plungers 33', one of which is shown immediately at the left of feeding station A', Fig. 16, engage selective butts 71' elevating jacks 62' to which they are attached a short distance sufficient to cause the butts 61' on such selected jacks to be engaged by a cam 92 which latter cam elevates the selected jacks causing the butts 64' of the selected needles to be elevated as indicated by the portion of the path 66' designated by 93. At the same time the butts 64' of the non-selected needles move horizontally at a low level 94. The described division of the needles may cause the elevated needles to knit the yarn fed to the said needles at the feeding station B' and the said yarn to float across the wales of the non-selected needles; however, the needle selection may be for the purpose of effecting the knitting of other forms of special or ornamental stitches. The cams 69, 91 thereafter engage the needle butts 64' and upper jack butts 87 of the selected needles and jacks thus causing the selected needles to draw new stitches through the stitches drawn at the feeding station A'. As the needle butts 64' leave the cam 90 a portion 95 thereof elevates the needles thus separating the needles and jacks as indicated in Fig. 17. As the needles and jacks approach the feeding station C' a plunger 33' is shown as elevating some of the jacks 62' which may be the jacks elevated preparatory to knitting at feeding station B' or other jacks. As before, the preparatory elevating movement of the jacks by the plunger 33' raises the lower butts 61' on the said jacks to be engaged by a cam 92, the raising of the jacks by the cam 92 correspondingly raising the needles as indicated at 93. The butts 61' of the non-selected jacks travel along the path 63' and as a consequence thereof do not affect the movements of their companion needles the butts 64' of which, however, engage and are elevated by a cam 96 which raises the non-selected needles to a tuck level at which level the old loops do not drop off the latches (if latch needles be used) of the needles, but the hooks of the needles are at a sufficient elevation to engage the yarn fed to the needles at the feeding station C'. After the needles are caused to draw new stitches by the cam 96 at feeding station C' their butts are engaged and the needles consequently elevated by cams 97 and 98 which raise all of the needles to a latch clear-

ing position after which they may all knit plain stitches at a feeding station corresponding to feeding station A'.

Although in the foregoing a feeding station A' at which plain stitches are knitted has been described as followed by a feeding station B' at which a float thread course is knitted and then by a feeding station C' at which tuck stitches are knitted, it should be understood that the sequence is merely illustrative, and that feeding stations such as A', B', C' may follow one another in any order, or adjacent feeding stations may be identical. Furthermore, while float stitches are knitted at feeding station B' and tuck stitches at feeding station C' it is within the scope of this invention to make other forms of special or ornamental stitches at one or more of the feeding stations.

It sometimes happens when changing patterns, i. e., reselecting the plungers 33' at the several feeding stations, that the selected jacks, the selective butts 71' of which have been partially elevated by plungers 33', have elevated the lower butts 61' to a level intermediate their upper and lower positions. The effect of such a relative positioning of the lower butts 61' with respect to a cam 92 is illustrated in Figs. 19-24 inclusive. The lower butts 61' of the non-selected jacks pass below the cam 92 when the needle cylinder 2 is again rotated after a pattern has been changed, the position of the said butts being shown in Fig. 20 and the path of the said butts being also illustrated at 98, Figs. 22 and 23. Furthermore, the jacks that have been fully raised by the plungers 33', upon resumption of knitting move along a path 99, Figs. 22 and 23. Accordingly the jacks whose butts, upon resumption of knitting move along paths 98 and 99 cause no trouble; however, the butts 61' that have, as just described, been partially elevated only by the withdrawn jacks which were active in accordance with the previous pattern, upon resumption of knitting will move along an intermediate path such as 100, Figs. 22 and 23. As knitting is resumed and the needle cylinder recommences to rotate, such butts 61' move along the dotted line paths 100, Figs. 22 and 23, towards the respective cams 92 and 92' and if the cam 92 or the cam 92' were held in a rigid position adjacent to the needle cylinder the butts 61' advancing along the paths 100 would strike the cam 92 or 92', as the case may be, at its leading edge but below the proper level 99 to engage the upper face of the cam and be elevated thereby; in other words, the butts 61' of such jacks would be broken. To avoid any such occurrence the cam 92 is pivotally mounted so that it may be swung away from the needle cylinder by a butt 61' advancing along an intermediate path 100 as indicated in Fig. 19.

The cam 92 is mounted upon cam plate 101 which is pivotally connected at 102 to an upstanding bracket 103 which is mounted upon and attached to the circular plate 4 through plate 7. A coil spring 104 is connected to the upper end of the cam plate 101 at 105 and at its other end is connected to a block 9', the said spring serving to maintain the cam yieldably in the position shown in Fig. 20. The movement of the cam 92 toward the needle cylinder is limited by means of stop screw or pin 106 which passes through an upwardly extending arm 107 of a bracket which is fastened to the circular base 4 of the machine as by screw 108. The pin or screw 106 is locked in adjusted position as by means of a second screw 109

which passes downwardly through the arm 107 and into contact with the screw 106.

Although the cam 92 shown in Fig. 22 is pivotally mounted as just described to swing away from the needle cylinder thus avoiding the breaking of butts 61', it is desirable that a butt the jack of which is to select its needle for the new pattern, which butt is adjacent to a butt travelling along an intermediate path 100, be permitted upon resumption of knitting, to engage and be elevated by the upper face of the cam 92. This desirable object is not always attained when using the cam 92 having a straight, inclined surface such as shown in Fig. 22, and it is with the purpose of overcoming the possibility of certain of the butts 61' not being elevated upon the resumption of knitting, that the cam 92' is used. The advantages inherent in the cam 92' as compared with the cam 92, will be obvious by inspection of Fig. 24. In this figure the dotted line represents the upper surface of the cam 92, Fig. 22, and the curved line immediately adjacent thereto represents the upper surface of the cam 92'. In the said Fig. 24 an intermediately positioned butt 61' is shown at 110 and an immediately adjacent butt 61', the jack of which has been selected according to the new pattern, is indicated at 111. It will be evident that if the straight cam 92 be used and assuming the cam 92 to be in the position shown in Fig. 19, that the butt indicated at 111 would pass back of the cam 92 before the said cam would be released to swing to a position adjacent to the needle cylinder such as shown in Fig. 20, and as a consequence thereof the said butt indicated at 111 would pass back of the cam and would hold the said cam in an outer position which would also prevent adjacent and following butts 61' being elevated by the cam 92. Now considering the cam 92' as indicated in Fig. 24 by a full line: the curving or cutting away of the upper face of cam 92' adjacent to its leading end permits the immediately following butt 61' indicated at 111, to be engaged and elevated by the upper surface of the said cam 92'. In other words, the cutting away of the portion of the cam 92' as compared with the cam 92 delays the interval of time which must elapse before a butt such as that indicated at 111 will be engaged and elevated.

It will be noted that the leading edges of the cams 92, 92' are curved as at 112 thereby to permit the intermediately positioned butts 61' to swing the cam to the position shown in Fig. 19; otherwise the said butts would be broken by the said leading edge of the cam.

To permit withdrawal of the brackets 8, Fig. 5, it is necessary to remove the screw 10. As shown in Fig. 13 a loosening of the screw 10 permits the bracket 8' to be removed from the machine, this being due to the provision of a slot 113 in the bracket 8' within which slot the shank of the screw 10 seats when the bracket 8' is in an assembled position.

Although a rotary needle cylinder type of machine has been illustrated obviously the cams could rotate in which event the needle cylinder would be stationary. Furthermore, it is not essential that the needles be arranged in a circle.

Pattern effects in a knitted fabric are ordinarily produced by, more or less, selective control of knitting instrumentalities which include needles, sinkers, jacks, pressers, etc., and wherever in the description or claims knitting instrumentalities are referred to it is the intention thereby to include any or all of the knitting instrumentalities that cooperate in the knitting of

plain or special stitches such as float or tuck stitches, the knitting of which has hereinbefore been described.

The hereinbefore described arrangement of plungers or elements and the control of the same provide a construction that permits quick changes in the positions of the said plungers so that changes can be readily effected manually and at any time at one or more of the feeding stations to the end that relatively short lengths of fabric having different patterns or other distinguishing characteristics can be set up and knitted in a relatively short length of time as compared with the time required when employing automatically controlled means for producing an equivalent output.

Although in the foregoing description specific terms have been employed and reference has been made to specific combinations of elements and arrangements thereof, such description taken in conjunction with the showing in the drawings has been merely illustrative and not with any intention of limiting the invention otherwise than required by the specific recitations in the claims themselves.

We claim:

1. An instrumentality selecting means for attachment to a knitting machine, including an upright support having two slotted and upstanding members, members mounted to slide in the slots aforesaid, spring means attached to the support and to the members for maintaining the members yieldingly in a forward position where they may act upon knitting instrumentalities, the said members being recessed on one edge thereof and means on the support adapted to seat within the mentioned recesses to hold the members in a retracted position where they do not act upon the said knitting instrumentalities.

2. Pattern mechanism for attachment to a knitting machine including a support and a series of thin, flat elements which, in their active and inactive positions are disposed in parallel juxtaposition, said elements being movably mounted in the support to move to and from an active position where they selectively act upon knitting instrumentalities, the said movements being effected manually, and spring means for yieldingly acting upon the said elements selectively to maintain them in one of their said positions.

3. Pattern mechanism for attachment to a knitting machine including a support and a series of thin, flat elements which, in their active and inactive positions are disposed in parallel juxtaposition, said elements being slidably mounted in the support to move to and from an active position where they selectively act upon knitting instrumentalities, the said movements being effected manually, and spring means for yieldingly acting upon the said elements selectively to maintain them in one of their said positions.

4. Pattern mechanism for attachment to a knitting machine including a support and a series of thin, flat elements which, in their active and inactive positions are disposed in parallel juxtaposition, said elements being movably mounted in the support to move to and from an active position where they selectively act upon knitting instrumentalities, the said movements being effected manually, and spring means for yieldingly acting upon the said elements selectively to move the said elements to a position to act upon the said knitting instrumentalities.

5. Pattern mechanism for attachment to a knitting machine including a support and a series

of thin, flat elements which, in their active and inactive positions are disposed in parallel juxtaposition, said elements being movably mounted in the support to move to and from an active position where they selectively act upon knitting instrumentalities, the said movements being effected manually, spring means for yieldingly acting upon the said elements selectively to move the said elements to a position to act upon the said knitting instrumentalities, and locking means to retain said members in inactive position.

6. Pattern mechanism for attachment to a knitting machine including a support and a series of thin, flat elements which, in their active and inactive positions are disposed in parallel juxtaposition, said elements being movably mounted in the support to move to and from an active position where they selectively act upon knitting instrumentalities, the said movements being effected manually, spring means for yieldingly acting upon the said elements selectively to move the said elements to a position to act upon the said knitting instrumentalities, and means for locking the said elements in an inactive position including shoulders on the elements adapted to engage the support, the locking engagement between the elements and support being effected by a rocking movement imparted to the elements as they are retracted.

7. A multi-feed knitting machine having a circular bank of knitting instrumentalities including needles, and cam means for imparting independent movements to the needles, there being relative rotary movement between the needles and the cam means, a plurality of feeding stations at each of which yarn is fed to some of the knitting instrumentalities, means individual to each of a plurality of said feeding stations acting in conjunction with the cam means and stationary with respect thereto, for acting upon the knitting instrumentalities to effect the knitting of variations in the fabric, the means last mentioned at each of said plurality of feeding stations including a plurality of thin, juxtaposed, like elements, said elements being individually movable to and from a position to affect the operations of the knitting instrumentalities, the said movements being effected by manual operation, said elements being maintained in their position to affect the operation of the knitting instrumentalities and when moved to their other position being ineffective upon the knitting instrumentalities, whereby quick and manual changes in the positions of the said elements can be readily effected at any time at desired ones of the means individual to each of a plurality of said feeding stations, so that relatively short lengths of fabric having different patterns or other distinguishing characteristics, can be set up and knitted in a relatively short length of time as compared with the time required when employing automatically controlled means for producing an equivalent output.

8. A multi-feed knitting machine having a circular bank of needles and cam means for imparting independent movements to the needles, there being relative rotary movement between the needles and the cam means, a plurality of feeding stations at each of which yarn is fed to the needles of the knitting machine, means individual to each of a plurality of said feeding stations acting in conjunction with the cam means and stationary with respect thereto, for acting upon the needles to effect the knitting of variations in the fabric, the means last mentioned at each of said plurality of feeding stations includ-

ing a plurality of thin, juxtaposed, like elements, said elements being movable to and from a position to effect the operations of the needles, the said movements being effected by manual operation, said elements being maintained in their position to effect the operation of the needles and when moved to their other position being ineffective upon the needles, whereby quick and manual changes in the positions of the said elements can be readily effected at any time at desired ones of the means individual to each of a plurality of said feeding stations, so that relatively short lengths of fabric having different patterns or other distinguishing characteristics, can be set up and knitted in a relatively short length of time as compared with the time required when employing automatically controlled means for producing an equivalent output.

9. A multi-feed knitting machine having a circular bank of knitting instrumentalities including needles, and cam means for imparting independent movements to the needles, there being relative rotary movement between the needles and the cam means, a plurality of feeding stations at each of which yarn is fed to some of the knitting instrumentalities, means individual to each of a plurality of said feeding stations acting in conjunction with the cam means and stationary with respect thereto, for acting upon the knitting instrumentalities to effect the knitting of variations in the fabric, the means last mentioned at each of said plurality of feeding stations including a plurality of thin, juxtaposed, like elements, said elements being individually movable to and from a position to affect the operations of the knitting instrumentalities, the said movements being effected by manual operation, and spring means for moving the said elements to one of their said positions, said elements being maintained in their position to affect the operation of the knitting instrumentalities and when moved to their other position being ineffective upon the knitting instrumentalities, whereby quick and manual changes in the positions of the said elements can be readily effected at any time at desired ones of the means individual to each of a plurality of said feeding stations, so that relatively short lengths of fabric having different patterns or other distinguishing characteristics, can be set up and knitted in a relatively short length of time as compared with the time required when employing automatically controlled means for producing an equivalent output.

10. A multi-feed knitting machine having a circular bank of knitting instrumentalities including needles, and cam means for imparting independent movements to the needles, there being relative rotary movement between the needles and the cam means, a plurality of feeding stations at each of which yarn is fed to some of the knitting instrumentalities, means individual to each of a plurality of said feeding stations acting in conjunction with the cam means and stationary with respect thereto, for acting upon the knitting instrumentalities to effect the knitting of variations in the fabric, the means last mentioned at each of said plurality of feeding stations including a plurality of thin, juxtaposed, like elements, said elements being individually movable to and from a position to effect the operations of the knitting instrumentalities, the said movements being effected by manual operation, and spring means for moving the said elements to a position to affect the operations of knitting instrumentalities, said elements being maintained

in their position to affect the operation of the knitting instrumentalities and when moved to their other position being ineffective upon the knitting instrumentalities, whereby quick and manual changes in the positions of the said elements can be readily effected at any time at desired ones of the means individual to each of a plurality of said feeding stations, so that relatively short lengths of fabric having different patterns or other distinguishing characteristics, can be set up and knitted in a relatively short length of time as compared with the time required when employing automatically controlled means for producing an equivalent output.

11. A multi-feed knitting machine having a circular bank of knitting instrumentalities including needles and jacks, and cam means for imparting independent movements to the needles and jacks, there being relative rotary movement between the needles, the jacks and the cam means, a plurality of feeding stations at each of which yarn is fed to some of the knitting instrumentalities, means individual to each of a plurality of said feeding stations acting in conjunction with the cam means and stationary with respect thereto, for acting upon the jacks, which jacks act upon their companion needles to effect the knitting of variations in the fabric, the means last mentioned at each of said plurality of feeding stations including a plurality of thin juxtaposed, like elements, said elements being individually movable to and from a position to affect the operations of the knitting instrumentalities, the said movements being effected by manual operation, said elements being maintained in their position to affect the operation of the knitting instrumentalities and when moved to their other position being ineffective upon the knitting instrumentalities, whereby quick and manual changes in the positions of the said elements can be readily effected at any time at desired ones of the means individual to each of a plurality of said feeding stations, so that relatively short lengths of fabric having different patterns or other distinguishing characteristics, can be set up and knitted in a relatively short length of time as compared with the time required when employing automatically controlled means for producing an equivalent output.

12. A multi-feed knitting machine having a circular bank of knitting instrumentalities including needles and jacks, and cam means for imparting independent movements to the needles and jacks, there being relative rotary movement between the needles, the jacks and the cam means, a plurality of feeding stations at each of which yarn is fed to some of the knitting instrumentalities, means individual to each of a plurality of said feeding stations acting in conjunction with the cam means and stationary with respect thereto, for acting upon the jacks, which jacks are rocked to act upon their companion needles to affect the knitting of variations in the fabric, the means last mentioned at each of said plurality of feeding stations including a plurality of thin juxtaposed, like elements, said elements being individually movable to and from a position to affect the operations of the knitting instrumentalities, the said movements being effected by manual operation, said elements being maintained in their position to affect the operation of the knitting instrumentalities and when moved to their other position being ineffective upon the knitting instrumentalities, whereby quick and manual changes in the positions of the

said elements can be readily effected at any time at desired ones of the means individual to each of a plurality of said feeding stations, so that relatively short lengths of fabric having different

5 patterns or other distinguishing characteristics, can be set up and knitted in a relatively short length of time as compared with the time required when employing automatically controlled means for producing an equivalent output.

10 13. A multi-feed knitting machine having a circular bank of knitting instrumentalities including needles and cam means for imparting independent movements to the needles, the circular bank of needles rotating and the cam means

15 being stationary during knitting, a plurality of feeding stations at each of which yarn is fed to some of the knitting instrumentalities, means individual to each of a plurality of said feeding stations acting in conjunction with the cam means

20 and stationary with respect thereto, for acting upon the knitting instrumentalities to effect the knitting of variations in the fabric, the means last mentioned at each of said plurality of feeding stations including a plurality of thin, juxtaposed, like elements, said elements being

25 individually movable to and from a position to affect the operations of the knitting instrumentalities, the said movements being effected by manual operation, said elements being maintained in their position to affect the operation of the knitting instrumentalities, and when moved to their other position being ineffective upon the knitting instrumentalities, whereby quick and manual changes in the positions of the said elements can be readily effected at any time at desired ones of the means individual to each of a plurality of said feeding stations, so that relatively short lengths of fabric having different patterns or other distinguishing characteristics, can be set up and knitted in a relatively short length of time as compared with the time required when employing automatically controlled means for producing an equivalent output.

40 14. A multi-feed knitting machine having a circular bank of needles and cam means for imparting independent movements to the needles, the circular bank of needles rotating and the cam means being stationary during knitting, a plurality of feeding stations at each of which yarn

45 is fed to the needles of the knitting machine, means individual to each of a plurality of said feeding stations acting in conjunction with the cam means and stationary with respect thereto, for acting upon the needles to effect the knitting

50 of variations in the fabric, the means last mentioned at each of said plurality of feeding stations including a plurality of thin, juxtaposed, like elements, said elements being movable to and from a position to affect the operations of the needles, the said movements being effected by manual operation, said elements being maintained in their position to affect the operation of the needles and when moved to their other position being ineffective upon the needles, whereby quick and manual changes in the positions of the said elements can be readily effected at any time at desired ones of the means individual to each of a plurality of said feeding stations, so that relatively short lengths of fabric having different patterns or other distinguishing characteristics, can be set up and knitted in a relatively short length of time as compared with the time required when employing automatically controlled means for producing an equivalent output.

15 A multi-feed knitting machine having a circular bank of knitting instrumentalities including needles, and cam means for imparting independent movements to the needles, the circular bank of needles rotating and the cam

5 means being stationary during knitting, a plurality of feeding stations at each of which yarn is fed to some of the knitting instrumentalities, means individual to each of a plurality of said feeding stations acting in conjunction with the

10 cam means and stationary with respect thereto, for acting upon the knitting instrumentalities to effect the knitting of variations in the fabric, the means last mentioned at each of said plurality of feeding stations including a plurality of thin,

15 juxtaposed, like elements, said elements being individually movable to and from a position to affect the operations of the knitting instrumentalities, the said movements being effected by manual operation, and spring means for moving the said

20 elements to one of their said positions, said elements being maintained in their position to affect the operation of the knitting instrumentalities and when moved to their other position being ineffective upon the knitting instrumentalities,

25 whereby quick and manual changes in the positions of the said elements can be readily effected at any time at desired ones of the means individual to each of a plurality of said feeding stations, so that relatively short lengths of fabric having different patterns or other distinguishing characteristics, can be set up and knitted in a relatively short length of time as compared with the time required when employing automatically controlled means for producing an equivalent output.

30 16. A multi-feed knitting machine having a circular bank of knitting instrumentalities including needles, and cam means for imparting independent movements to the needles, the circular bank of needles rotating and the cam means being stationary during knitting, a plurality of feeding stations at each of which yarn is fed to some of the knitting instrumentalities, means individual to each of a plurality of said feeding

45 stations acting in conjunction with the cam means and stationary with respect thereto, for acting upon the knitting instrumentalities to effect the knitting of variations in the fabric, the means last mentioned at each of said plurality of feeding stations including a plurality of thin,

50 juxtaposed, like elements, said elements being individually movable to and from a position to effect the operations of the knitting instrumentalities, the said movements being effected by manual operation, and spring means for moving the said elements to a position to affect the operations of knitting instrumentalities, said elements being maintained in their position to affect the operation of the knitting instrumentalities and when moved to their other position being ineffective upon the knitting instrumentalities, whereby quick and manual changes in the positions of the said elements can be readily effected at any time at desired ones of the means individual to each of a plurality of said feeding stations, so that relatively short lengths of fabric having different patterns or other distinguishing characteristics, can be set up and knitted in a relatively short length of time as compared with the time required when employing automatically controlled means for producing an equivalent output.

70 17. A multi-feed knitting machine having a circular bank of knitting instrumentalities, in-

75

cluding needles and jacks, and cam means for imparting independent movements to the needles, the circular bank of needles rotating and the cam means being stationary during knitting, a plurality of feeding stations at each of which yarn is fed to some of the knitting instrumentalities, means individual to each of a plurality of said feeding stations acting in conjunction with the cam means and stationary with respect thereto, for acting upon the jacks, which jacks act upon their companion needles to effect the knitting of variations in the fabric, the means last mentioned at each of said plurality of feeding stations including a plurality of thin, juxtaposed, like elements, said elements being individually movable to and from a position to affect the operations of the knitting instrumentalities, the said movements being effected by manual operation, said elements being maintained in their position to affect the operation of the knitting instrumentalities and when moved to their other position being ineffective upon the knitting instrumentalities, whereby quick and manual changes in the positions of the said elements can be readily effected at any time at desired ones of the means individual to each of a plurality of said feeding stations, so that relatively short lengths of fabric having different patterns or other distinguishing characteristics, can be set up and knitted in a relatively short length of time as compared with the time required when employing automatically controlled means for producing an equivalent output.

18. A multi-feed knitting machine having a circular bank of knitting instrumentalities, including needles and jacks, and cam means for

imparting independent movements to the needles and jacks, the circular bank of needles rotating and the cam means being stationary during knitting, a plurality of feeding stations at each of which yarn is fed to some of the knitting instrumentalities, means individual to each of a plurality of said feeding stations acting in conjunction with the cam means and stationary with respect thereto, for acting upon the jacks, which jacks are rocked to act upon their companion needles to affect the knitting of variations in the fabric, the means last mentioned at each of said plurality of feeding stations including a plurality of thin, juxtaposed, like elements, said elements being individually movable to and from a position to affect the operations of the knitting instrumentalities, the said movements being effected by manual operation, said elements being maintained in their position to affect the operation of the knitting instrumentalities and when moved to their other position being ineffective upon the knitting instrumentalities, whereby quick and manual changes in the positions of the said elements can be readily effected at any time at desired ones of the means individual to each of a plurality of said feeding stations, so that relatively short lengths of fabric having different patterns or other distinguishing characteristics, can be set up and knitted in a relatively short length of time as compared with the time required when employing automatically controlled means for producing an equivalent output.

WILLIAM L. SMITH, Jr.
ROBERT H. LAWSON.

35