

J. M. BATCHELDER.

Improvement in Electro-Magnetic Watch-Clocks.

No. 130,971.

Patented Sep. 3, 1872.

Figure II-

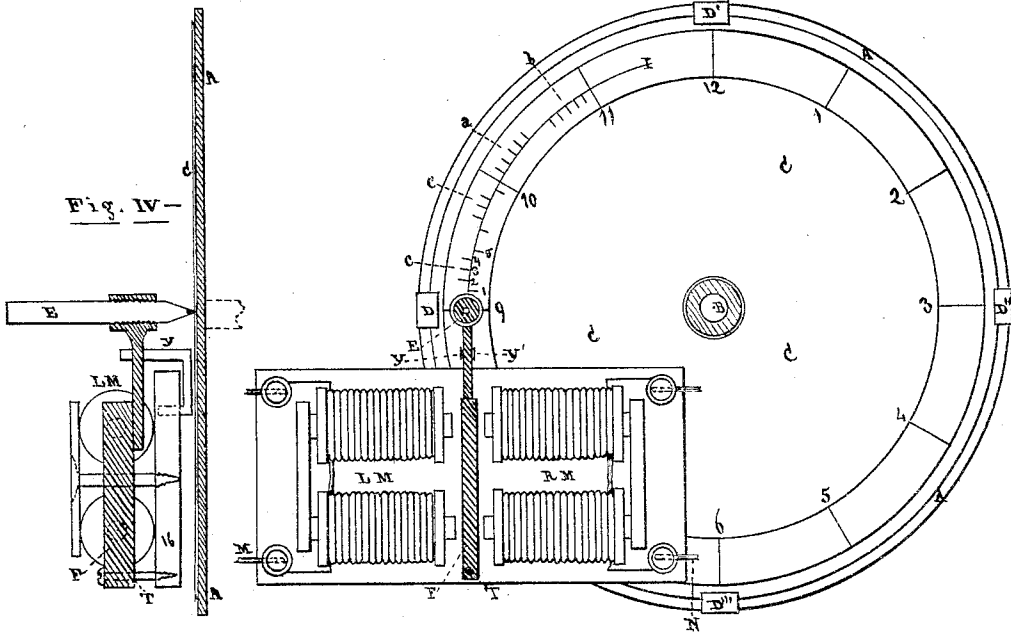

Fig. IV-

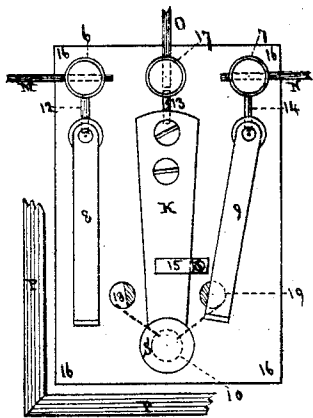
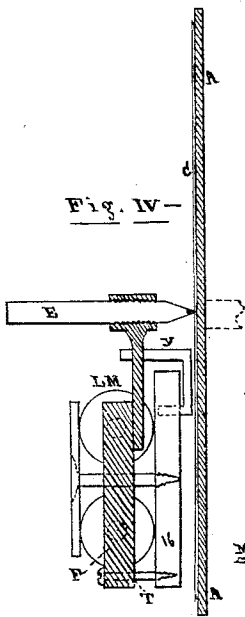

Figure III.-

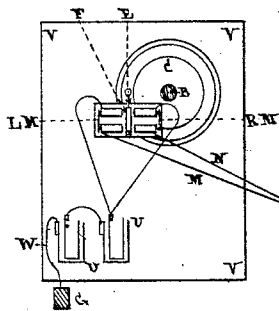
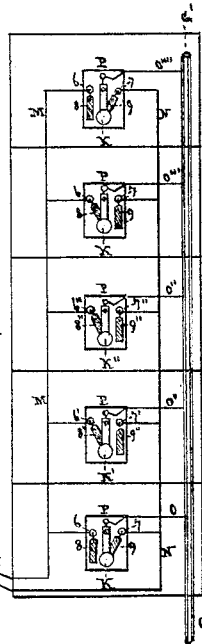

Figure I.-



Witnesses.
 Franklin Hunt.
 Henry S. Rowe

Inventor
 John M. Batchelder.

UNITED STATES PATENT OFFICE.

JOHN M. BATCHELDER, OF CAMBRIDGE, MASSACHUSETTS.

IMPROVEMENT IN ELECTRO-MAGNETIC WATCH-CLOCK.

Specification forming part of Letters Patent No. 130,571, dated September 3, 1872.

To all whom it may concern:

Be it known that I, JOHN M. BATCHELDER, of Cambridge, in the county of Middlesex and State of Massachusetts, have invented a new and useful Improvement in "Electro-Magnetic Watch-Clocks;" and I do hereby declare that the following is a full and exact description thereof, reference being had to the accompanying drawing making a part of this specification.

This instrument is intended to show whether a watchman or guard makes his rounds or traverses his beat with regularity, and visits the several stations at the required time. The motive force is electro-magnetism; and the system or method adopted is such that only two conducting or line-wires are required between the premises or stations that are to be watched and the office or room in which the record-clock is kept. The watchman has no access to the record-clock, or to the interior of the boxes containing the connecting-keys that are placed at the several stations. The only mechanical movements are the depression of a telegraph-key at the station, and the direct action of a single armature placed between two electro-magnets at the record-clock, no circuit-breaker being required. In this description the line is supposed to be worked on an open circuit.

In Figure I the relative position of the record-clock, the conducting-wires, the batteries, and the key-boxes are represented. Fig. II is an elevation or front view of the record-clock; Fig. IV, side view of the same. Fig. III is a plan of the key-box, the key, and the double switch.

The dial A, Fig. II, is a plain circular disk, fastened to the hour-hand arbor B of a common clock. This has a face, C, of paper, held to it by suitable clamps, D, and receives the marks of a pencil, E, that is secured to the vertical armature F of two electro-magnets, L M and R M, placed opposite to each other near the lower half of the dial. When the right-hand magnet R M is charged the armature F, which has its center of motion at T, is drawn to the right, and the pencil E makes a short mark to the right, as at 1, and when the left-hand magnet L is charged the pencil makes a short mark to the left, as at 2. When no current is passing, and neither of the magnets is

charged, the armature remains in a vertical position between the two magnets, being held in this position by the springs Y Y'. The central adjustment of the armature is effected by means of these springs. When the armature is vertical the point of the pencil E, in contact with the paper dial C, traces the continuous line I as the clock-face revolves, which forms a base or point of departure for the short record lines 1 2 3 4 5. The paper dial is printed with the hour spaces from one to twelve, with division marks of five minutes each. It is to be removed daily, and filed as a record of the fact that the watchman has or has not visited the stations in the required manner. The key-boxes P P, Fig. III, in each station or room are numbered. The knobs S S of the circuit-keys K K project through the cover of the box, which is locked so that the watchman can have no access to the interior. The knob may be protected by a cap or shield at hours when the clock is not in use. The flexible signal-key K is affixed to a back-board, 16, at one end, and has, at the other end, a knob, S, the depression of which brings the metallic key in contact with the anvil 10 just below it. A guard, 15, limits the action of the spring. The fixed end of the key is connected, by the wire 13, with the screw-cup 17, that holds the ground-wire O. The position of the switch-connections is shown by the heavy dotted lines. The fixed plate 18 on the left side of the key connects with the anvil 10, and the switch 8, when turned into contact with it, connects, through the wire 12 and screw-cup 6, with the line-wire M. On the right side of the key the fixed plate 19 connects with the anvil 10, and receives the end of the switch 9 that connects, through the wire 14 and screw-cup 7, with the line-wire N. When the switch 9 is in the position shown in Fig. III the current flows through the right magnet R M; and when it is removed from the plate 19, and the switch 8 is turned upon the plate 18, the current flows through the left magnet L M. The relative position of the clock, the magnets, the two line-wires, and the key-stations or premises that are to be guarded, is shown in Fig. I.

The battery U may be placed in the office or central station, which is supposed to be within the boundary lines V V. A wire, W, leading to one of the poles of the battery, is connected

with the ground by soldering it to a water or gas pipe; or the wire may lead to a ground-plate, G. From the other pole of the battery the line-wire M leads through the electro-magnet L M, and thence to the key-box P in the first room or station, where it enters the screw-cup 6 of the signal-key. From the same pole of the battery the line-wire N leads through the opposite electro-magnet R M, and thence to the key-box P in the first room or station, where it enters the screw-cup 7. The line-wire M, leading from the left-hand magnet L M, is continued to each of the screw-cups 6 6' 6'', &c., at each station; and the line-wire N, leading from the right-hand magnet R M, is continued to each of the screw-cups 7 7' 7'', &c. The fixed end of each station-key K is connected, by the wire 13, the screw-cup 17, and the wires 0 0' 0'', &c., with a gas or water pipe, or with a ground-plate, G'.

If all the switches 8 8' 8'' at the left hand are in connection with the signal-keys K K' K'', the marks made on the paper dial C of the clock will appear as shown at *a* on the left of the curved line I, Fig. II; and if all of the switches 9 9' 9'', at the right hand, are in connection with the signal-key, the marks appear as at *b* upon the right of the curved line I. If the switches are placed as in Fig. I, the marks are as shown at *c*, Fig. II, the first one being on the right side; then three marks on the left side, and then one on the right side of the curved line. Each group of marks is the record of one entire "round" of the watchman, and has a peculiar and distinctive character, in correspondence with the variable position of the series of switches 8 and 9. By changing the position of the switches at either of the stations a great variety in the position of the groups of radial lines is obtained, any

one of which may be used by the manager, and changed daily or weekly at his discretion. If there are five stations, the number of varieties of groups that may be made is 32. If there are six stations, 64; seven stations, 128; if ten stations, 1024, &c. Each group of marks *cc*, constituting one round of the watchman, is constantly repeated, unless a change is made in the position of one or more of the switches of the signal-key. A mark shows the time of contact, and a space shows the time occupied by the watchman in passing from one station to another. The sound made by the contact or touch of the knob S and key K is the same whether the right or the left switch is in use.

I claim—

1. The combination of a double electro-magnet and a central armature, carrying a pencil, arranged so that marks may be made upon one side or the other of a central line upon the recording-disk, substantially as herein specified.

2. I claim, in combination with the above, the two independent circuits and adjustable switches L and R, whereby the position and grouping of the marks made may be varied, substantially as specified.

3. I claim the two independent circuits from each station to the recording apparatus, for the purpose of varying the mark made from each station, substantially as specified.

4. I claim, in combination with such circuits, the switches, for throwing the current from one to the other of the magnets of the double electro-magnet, substantially as specified.

JOHN M. BATCHELDER. [L. s.]

In presence of—

FRANKLIN HUNT,
HENRY S. ROWE.