

(No Model.)

W. VON BOKERN.
BOTTLE.

No. 524,694.

Patented Aug. 14, 1894.

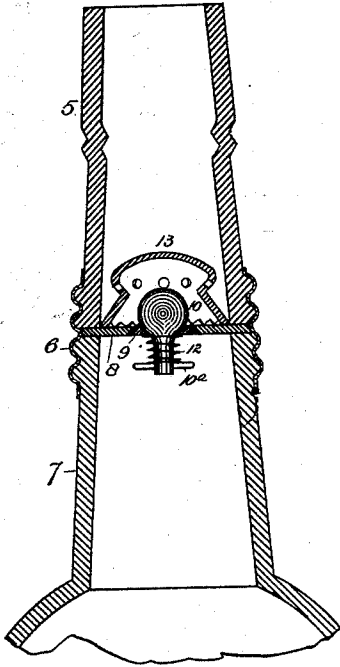

Fig. 2.

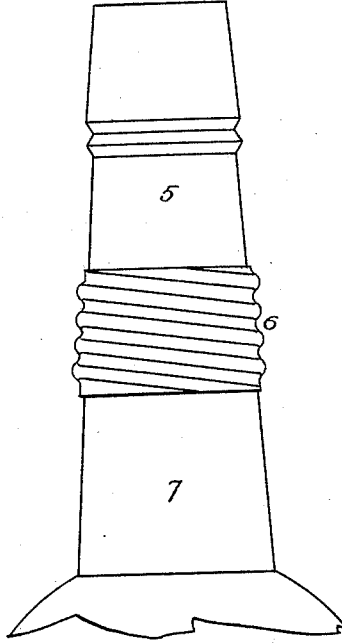

Fig. 1.

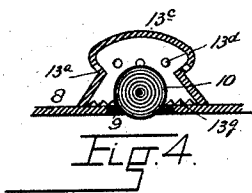

Fig. 4.

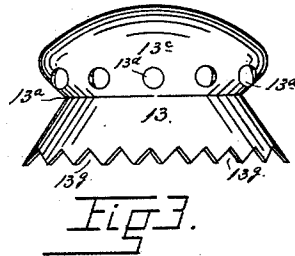

Fig. 3.

WITNESSES:

J. J. O'Connell.
Chas. E. Dawson.

INVENTOR
William Von Bokern
BY *A. J. Brien*
ATTORNEY

UNITED STATES PATENT OFFICE.

WILLIAM VON BOKERN, OF DENVER, COLORADO, ASSIGNOR OF ONE-HALF
TO HERBERT HEATLEY, OF SAME PLACE.

BOTTLE.

SPECIFICATION forming part of Letters Patent No. 524,694, dated August 14, 1894.

Application filed December 8, 1893. Serial No. 493,084. (No model.)

To all whom it may concern:

Be it known that I, WILLIAM VON BOKERN, a citizen of the United States of America, residing at Denver, in the county of Arapahoe and State of Colorado, have invented certain new and useful Improvements in Bottles; and I do declare the following to be a full, clear, and exact description of the invention, such as will enable others skilled in the art to which it appertains to make and use the same, reference being had to the accompanying drawings, and to the figures of reference marked thereon, which form a part of this specification.

My invention relates to improvements in bottles, and the object of the improvement is to prevent the refilling without destroying the original label. Bottles of ordinary construction, originally filled with superior goods and bearing appropriate labels may be refilled with inferior goods, thus defrauding the manufacturer whose label the bottle bears, and at the same time imposing upon the public or purchasers of the inferior goods. To overcome this difficulty and provide a bottle which cannot be refilled without leaving marks whereby the fraud may be detected, I have invented the bottle hereinafter described and claimed, and which will be fully understood by reference to the accompanying drawings in which is illustrated an embodiment thereof.

In the drawings, Figure 1 is an elevation of the upper part or neck of the bottle, the lower part or body thereof being broken away. Fig. 2 is a longitudinal section taken through the neck of the bottle. Fig. 3 is a detail view of the safety cap covering the valve. Fig. 4 is a vertical section taken through the safety cap and valve seat, showing a modified form of valve.

Similar reference characters indicating corresponding parts in the views, let the numeral 5 designate the detachable nozzle of the bottle which is connected with the integral neck portion 7 of the body by a screw sleeve 6, the parts 5 and 7 being correspondingly threaded to receive the connecting sleeve. Between the parts 5 and 7 is placed an apertured disk 8 which is held in place by the adjacent edges of the engaging parts which are suitably fashioned to retain the disk. This

disk may be composed of any suitable material which may be found practicable; cork is believed preferable. Within the central aperture of the cork disk, there may be inserted a separate valve seat 9 preferably composed of glass, and pressed tightly into the aperture of the disk, whereby it will retain its position under all circumstances. The valve 10 is composed of the enlarged ball-shaped upper portion and the reduced lower stem portion which projects through the apertured valve seat, and is preferably provided with the retaining pin 10^a which forms a stop to prevent the valve stem from passing entirely through the seat. The stem may also be surrounded by a weak coil spring 12. The strength of the spring must be so regulated, that when the bottle is tipped to a suitable position for discharging its contents, the spring will yield to the weight of the enlarged ball-shaped upper part of the valve, and allow the contents of the bottle to pass readily through the aperture in the seat. The valve 10 is preferably formed of glass, though it may be formed of any material which may be found suitable. The valve and seat should be so constructed that when the bottle is in the upright position, they will fit perfectly and form a tight or close joint against the entrance of liquid poured into the nozzle.

In Fig. 4 I have shown a ball valve which may be employed in connection with the safety cap.

Inserted in the nozzle of the bottle, and covering the valve in such a manner as to protect it from being tampered with from the outside, is the cap 13, the bottom of which is made of such size as to fit nicely within the nozzle and engage the disk 8 at the same time. The nozzle of the bottle should be so constructed that it diminishes slightly in size from the disk 8 upward, whereby the cap will be retained securely in position by virtue of the shape of the nozzle.

The cap 13 is apertured to allow the escape of the liquid, but the apertures are so formed and located that they do not permit access to the valve through the agency of any instrument inserted from the outside.

In the drawings, I have illustrated a circular cap formed largest at its bottom or lower edge and diminishing in size to a point 13^a from

which it enlarges into a top 13^c, which, however, must not be of sufficient size to fill the nozzle. I have shown in the cap two avenues of escape for the liquid, namely; the apertures 13^d and the notches 13^e formed in the lower part of the cap whose edge is toothed as illustrated. Either or both of these avenues may be employed.

After the bottle is filled, the valve mechanism and safety cap are placed in position, and the nozzle attached by means of the screw sleeve. The label is then so applied as to cover the sleeve and extend both above and below it, whereby the nozzle cannot be removed without destroying the label or trademark of the manufacturer.

Having thus described my invention, what I claim is—

1. In a bottle, the combination of the body part provided with the integral threaded neck portion, the nozzle threaded to correspond with the neck portion, the screw sleeve for connecting the nozzle and neck portions, the apertured disk, the valve adapted to engage the aperture in the disk which forms its seat, and the apertured safety cap covering the valve, substantially as described.

2. In a bottle, the combination of the body part having an integral neck portion, the detachable nozzle, suitable means for connecting the nozzle and neck, the apertured disk located between the neck and the nozzle, the valve having the enlarged upper portion and the stem projecting through the aperture in the disk, and the apertured safety cap adapted to fit within the nozzle or neck and protect the valve, substantially as described.

3. In a bottle, the combination of the body

part having the integral neck portion, the detachable nozzle, means for connecting the nozzle with the integral neck, the apertured disk located between the neck and nozzle, the valve having the enlarged top and a stem projecting through the aperture in the disk and provided with a stop below the disk, and the safety cap whose lower edge is adapted to fit within the nozzle or neck, its upper portion being somewhat smaller to permit the escape of the liquid through the apertures below, substantially as described.

4. In a bottle, the combination of the body portion having the integral neck, the detachable nozzle, means for connecting the neck and nozzle, the apertured disk located between the neck and nozzle, the separate valve seat inserted in the aperture of the disk, the valve adapted to engage the seat, and the apertured safety cap, substantially as described.

5. In a bottle, the combination of the body part provided with the integral neck, the detachable nozzle, means for connecting the neck and nozzle, the apertured disk located at the joint between the nozzle and neck, the valve provided with the stem projecting through the aperture in the disk and provided with a stop below the disk, the coil-spring surrounding the stem and located between the stop and disk, and the apertured safety cap located above the disk and covering the valve, substantially as described.

In testimony whereof I affix my signature in the presence of two witnesses.

WILLIAM VON BOKERN.

Witnesses:

G. J. ROLLANDET,
CHAS. E. DAWSON.