

No. 653,003.

Patented July 3, 1900.

S. EVANS.
ILLUMINATED SIGN.

(Application filed Mar. 14, 1900.)

(No Model.)

3 Sheets—Sheet 1.

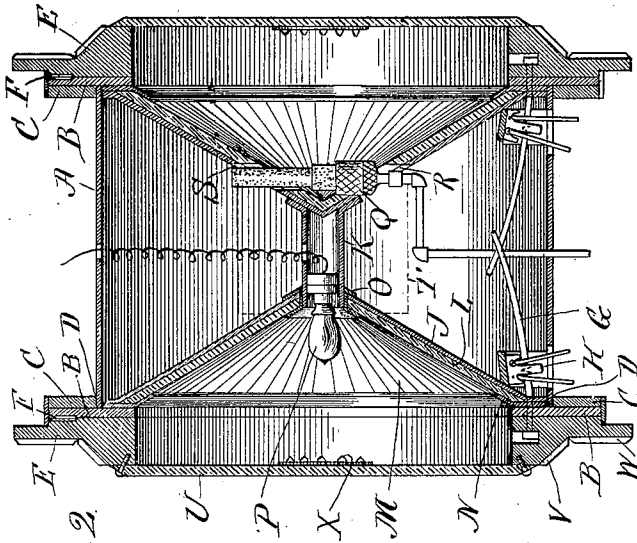

Fig. 2.

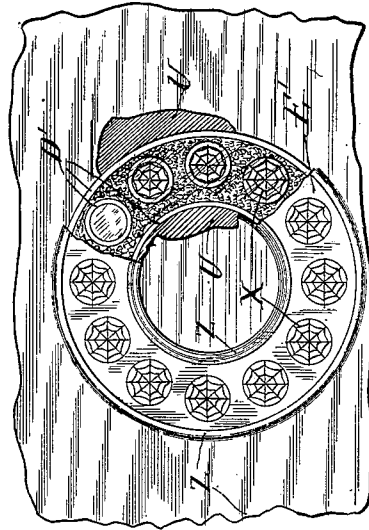

Fig. 3.

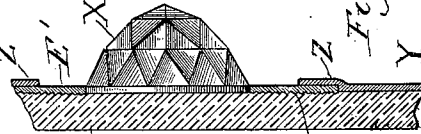

Fig. 4.

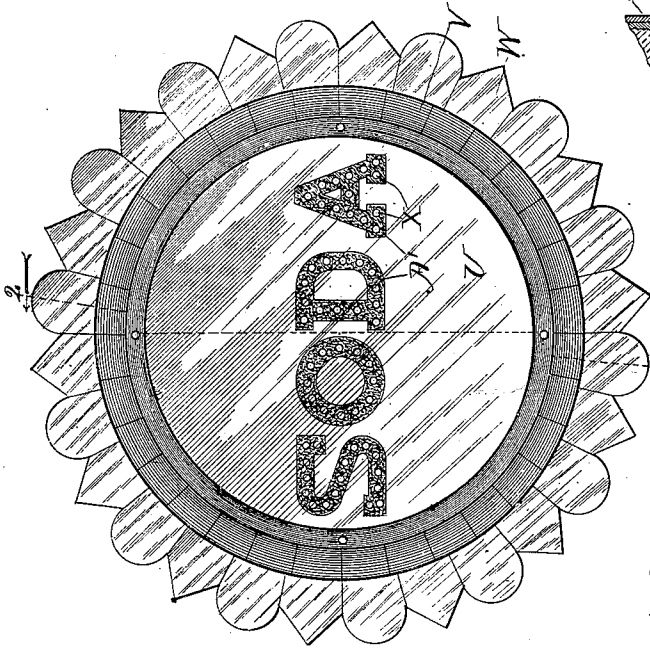

Fig. 1.

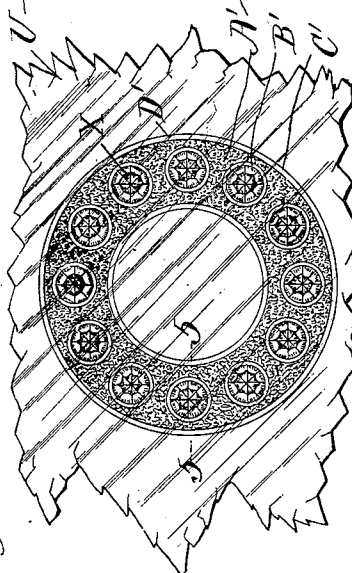

Fig. 5.

Witnesses:
W. C. Cooley
Wm. Geiger

Inventor:
Samuel Evans
By Coburn, Hibben & McClroy,
Attorneys

No. 653,003.

Patented July 3, 1900.

S. EVANS.
ILLUMINATED SIGN.

(No Model.)

(Application filed Mar. 14, 1900.)

3 Sheets—Sheet 2.

Fig 6

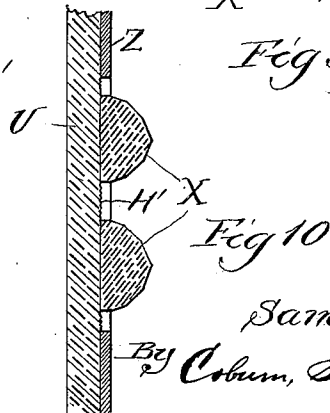
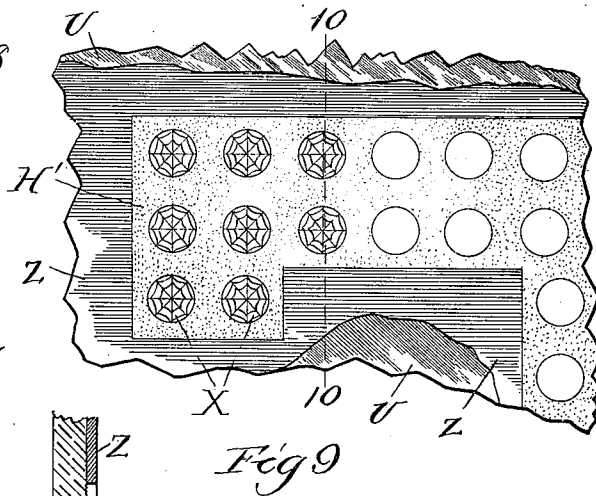
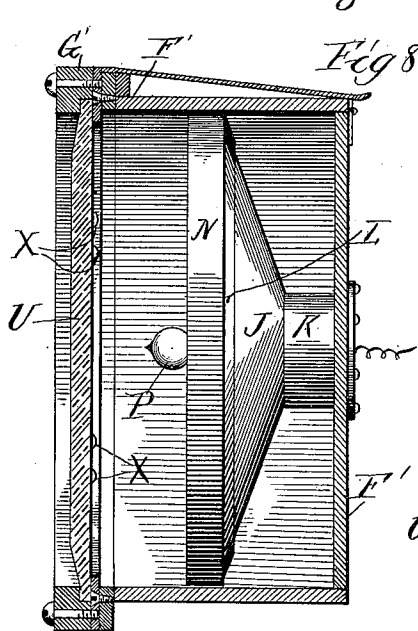
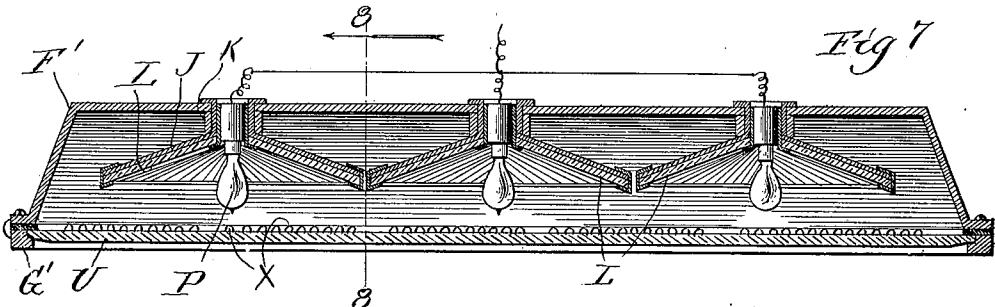
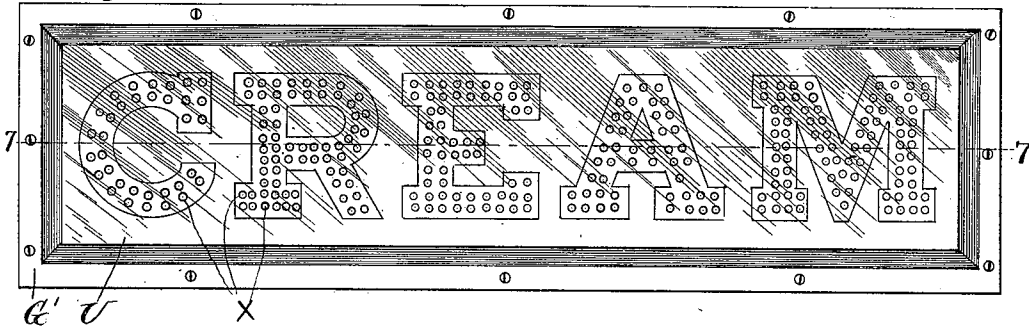

Witnesses:
W. C. Corlies
Wm. Geiger

Inventor:
Samuel Evans
 By *Coburn, Hibben & McCloy,*
Attys.

No. 653,003.

Patented July 3, 1900.

S. EVANS.

ILLUMINATED SIGN.

(Application filed Mar. 14, 1900.)

(No Model.)

3 Sheets—Sheet 3.

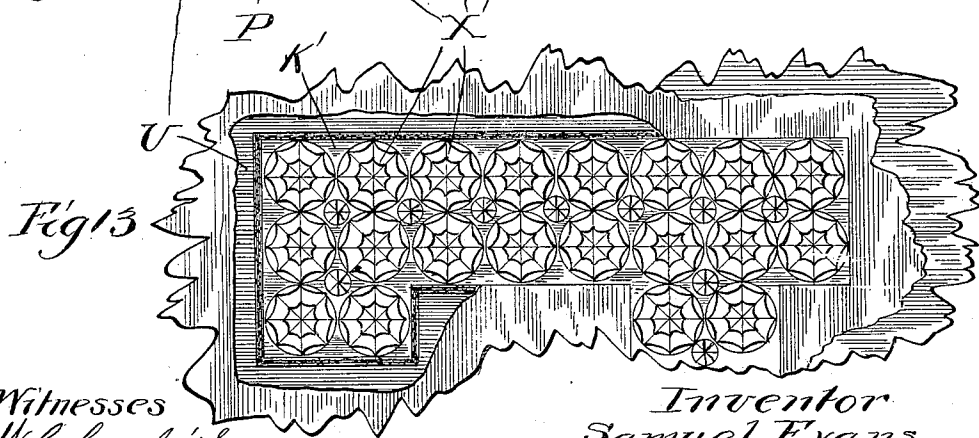
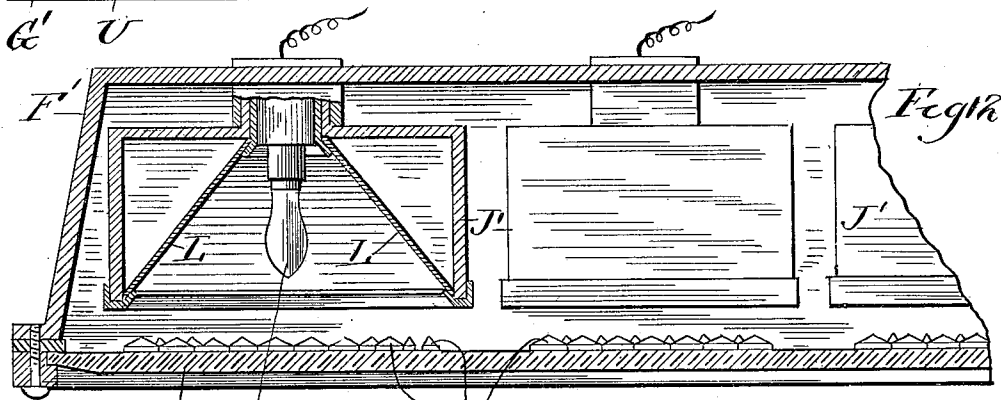
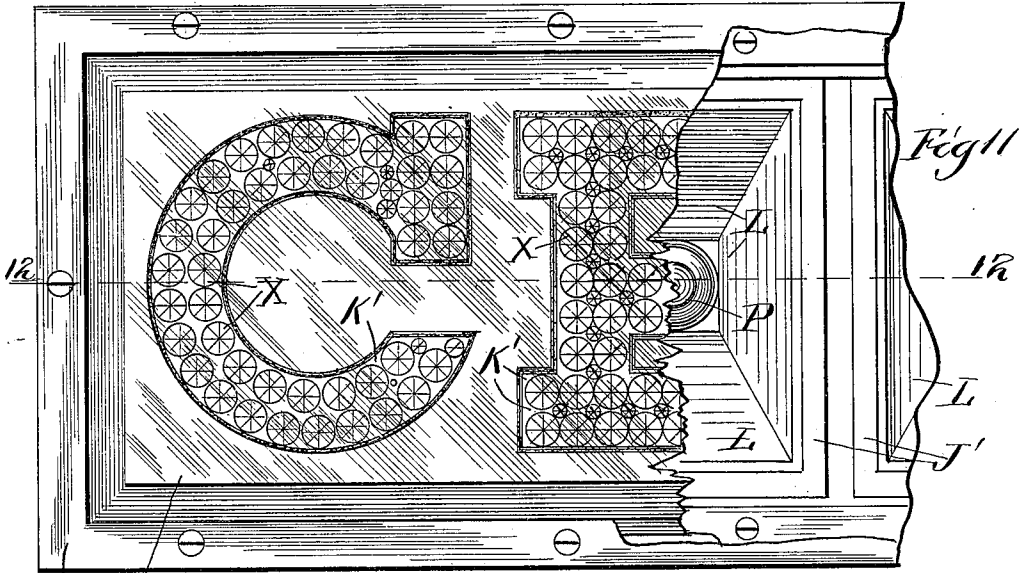

Witnesses
W. B. Coates
Wm. Geiger

Inventor
Samuel Evans

By Coburn, Hibben & McCloy, Attys

UNITED STATES PATENT OFFICE.

SAMUEL EVANS, OF CHICAGO, ILLINOIS, ASSIGNOR OF ONE-HALF TO CHARLES L. RAWSON, OF SAME PLACE.

ILLUMINATED SIGN.

SPECIFICATION forming part of Letters Patent No. 653,003, dated July 3, 1900.

Application filed March 14, 1900. Serial No. 8,573. (No model.)

To all whom it may concern:

Be it known that I, SAMUEL EVANS, a resident of Chicago, in the county of Cook and State of Illinois, have invented certain new and useful Improvements in Illuminated Signs, of which the following is a specification.

My invention relates to certain new and useful improvements in illuminated signs; and it is designed, primarily, to produce a sign which at night can be illuminated at a slight expense, so as to render the design thereof readily perceived at a considerable distance and which during the day-time shall present a brilliant, striking, and artistic effect. I attain these objects by certain novel constructions, which will be fully described in the following specification and the essential features thereof set out in the claims.

Referring to the three sheets of drawings, in which I have shown three specific forms of my invention, the same letters of reference are used to designate identical parts in all the views, Figures 1 to 5 on the first sheet representing one form, Figs. 6 to 10 on the second sheet another form, and Figs. 11 to 13 on the third sheet another and preferred form.

Fig. 1 is a front elevation of one form of my improved sign. Fig. 2 is a section on the line 2 2 of Fig. 1. Fig. 3 is an enlarged detail of one of the characters seen from the front. Fig. 4 is a view similar to Fig. 3 seen from the rear and with some of the parts or coatings broken away to more clearly disclose the construction. Fig. 5 is a sectional view, on a larger scale, as on the line 5 5 of Fig. 3, showing the mounting of one of the jewels. Fig. 6 is a front elevation of another form of my improved sign. Fig. 7 is a plan view thereof in section on the line 7 7 of Fig. 6. Fig. 8 is a sectional view, on an enlarged scale, on the line 8 8 of Fig. 7. Fig. 9 is a rear elevation, on a still larger scale, of a portion of one of the letters with some of the coatings broken away to more clearly illustrate the construction. Fig. 10 is a sectional view, on a still larger scale, on the line 10 10 of Fig. 9. Fig. 11 is a front elevation of a portion of a modified form of the sign with a portion of the front thereof broken away to show the interior construction. Fig. 12 is a horizontal section on the line 12 12 of Fig.

11, and Fig. 13 is a fragmentary view of the rear side of the front plate on an enlarged scale.

A is a cylinder which may be conveniently constructed of sheet metal and which furnishes a framework of the desired shape when a double circular sign is to be employed, as in the first form shown. This cylinder A is furnished with suitable supports (not shown) and has at its ends the annuli B and C, which may be conveniently made of wood and secured together so as to form the offsets at D by reason of the inner diameter of the annulus C being the greater, and by which offsets they are conveniently placed upon the cylinder A, to which they are secured in any desired manner. Outside of each of these annuli B is another annulus E, which may also be conveniently constructed of wood and of the cross-section shown in Fig. 2. Each of these annuli E is conveniently hinged at its top by the hinge F to its cooperating annulus, the hinge being for the purpose of swinging the annulus E away from the annulus B and permitting a ready access to the interior of the sign. As a convenient construction for holding the annulus E closed or in any desired position to which it may be opened I employ the rod G, which is bent on a curve, with the pivot of the hinge F as a center, and has one end secured in the annulus E at a point opposite to the hinge F. This rod G passes through the annulus B into the interior of the cylinder A, where it is held by any form of clamping mechanism that may be desired; but I have shown it as held by an ordinary transom-clamp H, which cooperates with the rod G in any desired position. Secured at the edges of the cylinder A are the inverted conical-shaped disks J, which are conveniently constructed of sheet metal and which may be connected at their centers by the tube K, which is also conveniently constructed of metal. Just outside of the disk J, I place a reflector L, which may be conveniently formed of a plurality of elongated triangular strips M of cheap mirror-glass. These strips are secured at their inner and outer ends by the annuli N and O, respectively, these annuli being shaped to hold the parts in position, as will be clearly seen, and the

annulus O being secured to the tube K, as seen on the right-hand half of Fig. 2. For the purpose of illumination I may employ an incandescent electric light, as P, as seen at the left-hand side of Fig. 2, or I may employ a Welsbach or other gas-burner, as seen at Q on the right-hand side of the figure, which burner of course will be connected with some suitable supply of gas by the tube shown. Where the gas-burner is employed, it will necessitate some changes in the construction of the central portion of the reflector, as the apertures R and S must be made therein to accommodate the burner and its chimney. A door T may be formed in the cylinder A to permit of access to the central portion thereof to manipulate the lighting apparatus.

The visible portion of the sign I preferably form of glass, although it will be understood that it might be constructed of other transparent or highly-translucent materials, so far as the illuminating feature of it is concerned. The central portion U is constructed of a sheet of glass, preferably plate, which is secured to the outer portion of the annulus E by screws in the customary manner. An ornamental edge may be employed, if desired, although it forms no feature of my invention, and in the one shown I employ the facets V, consisting of rectangular pieces of plate-glass, which may have beveled edges and a mirror-backing and be secured upon the inclined surface of the annulus E by screws or in any other convenient manner. The extreme outer portion of the edge is shown as formed by the facets W, which may be of different shapes and are formed of plate-glass, which may have beveled edges and have designs on the back thereof in chipped glass, which is silvered or gilded in the customary manner to give a brilliant effect. As previously stated, the front portion U is of plain glass, and the principal design therein is formed by some kind of ornamentation on the back thereof that will contrast vividly in the day-time with the background, which is ordinarily black or some dark color, against which the design stands out prominently. I might make this ornamentation of the design by merely employing a material such as silvering or gilding, or any other material contrasting with the main color forming the background, on plain glass. In case the design is in glass chipped to a line, as in the form under consideration, where the word "Soda" is shown, I preferably gild or silver it, as that contrasts forcibly with almost any color of background in the day-time.

Centrally located throughout the letters are the rows of jewels X, which may be constructed of glass cut in the shape of plano-convex lenses, but which I preferably give the shape of rose diamonds and which are in either case fastened with the flat side against the rear portion of the glass, which at these points is not chipped or ground, but is preferably clear to permit the free passage of the light used

for illumination. Of course the jewels are permanently connected to the glass by a cement which should be perfectly transparent and unaffected by heat or moisture and which completely covers the flat side of the jewels, all of which side is, as said, against the glass. I ordinarily use clear glass jewels, although it will be understood that colored jewels might be used, except that they are not so efficient in making the design stand out prominently, the white light transmitted by them being best for this purpose. As previously stated, the background, as at Y, of the sign is preferably painted black or some other dark color upon the rear surface of the glass. Referring to Figs. 3 to 5, which show the details of the construction of one of the letters, Y, as before, represents the dark background, which is formed by a coat of paint, as Z. The chipped surface A', as well as the rings B' and C', of clear glass, which may be used to form the outlines of the letters and the boundaries around the jewels, are coated with a layer D' of silvering or gilding, as the case may be, which in turn is preferably protected by a coating E' of tin or lead foil, in which the jewels X are inserted. The entire rear surface of the plate U is then painted over, excepting the surface of the jewels X, so as to be completely impervious to the light except where it is permitted to pass through the jewels. Of course it will be understood that it is not necessary to paint over the tin or lead foil, as it, while intact, prevents the passage of light.

The operation of the illuminating portion of my sign will be readily apparent. The single incandescent light located at the center of the reflector serves to throw a flood of light on the convex surface of the jewels X, which on account of the generally-convex shape of the portions exposed to the light can receive and transmit through the clear glass on which they are placed a much larger amount of light than if no jewels were employed, and as a result with the comparatively-feeble illumination of a single incandescent light or lamp the outlines of the letters or design stand out with great prominence, and the jewels present an additional beautiful effect by reason of the optical illusion which makes them appear to be on the outer surface of the glass, and the light passing therethrough shows the outlines of the facets when cut jewels are employed.

In Figs. 6 to 10 I show another form of my design operating on the same principle, but with slightly-different details of construction, as will be more fully set out. When an elongated sign is employed, as in the present case, I form a box-like casing F', in the back of which are secured the reflectors L, which may be of the construction which I have previously set out. I conveniently place these reflectors side by side, as near together as they can be placed, and in the design shown each reflector, with its light P, is located so as to furnish the illumination for two letters, al-

though any desired proportion may be used, and by means of the employment of the reflectors the illumination is practically the same for all parts of the letters. The box-like casing is suitably supported and has the front plate U secured therein in any desired manner, it being shown as secured by the rectangular framework G', screwed onto the main frame F' and overlapping the plate U.

In this form of sign I illustrate a slightly-different construction, where instead of having the main portion or letters of the design formed by the use of an opaque coloring contrasting with the main portion of the background I make the contrast by grinding the letters, as at H', except, of course, the portions which are covered by the jewels X. The employment of the ground-glass letter does not make so vivid a contrast with the background in the day-time as one in which the background of the letter is formed by some opaque material contrasting vividly with the color of the main background; but when the sign is illuminated at night the ground-glass body of the letter permits the passage of a mellow light in which the design appears very boldly by the action of the light passing through the jewels and the clear-glass portions in front of them, the effect produced by this combination being very striking and pleasing. In Fig. 9 I have shown a portion of the rear side of the plate U with the coating of paint Z broken away at the edges to show the clear glass upon which it is placed and with some of the jewels X removed, so as to show the clear-glass circles upon which they are placed contrasting with the ground-glass surface H' surrounding them. In the design shown I have made a variation by placing the jewels in double rows instead of in a single row, as shown in the previous sheet.

In Figs. 11 to 13 I have shown the preferred form of my invention, and I have shown a sign of the same general design shown in Figs. 6 to 10. In this form the modifications are in the construction of the reflectors, which I preferably make of a rectangular form, one to each character of the ordinary size, and instead of making the reflectors circular and of a large number of pieces I form them of the four quadrilateral sheets L of mirror-glass, which are suitably supported in the boxes J'. The principal feature of the modification, however, is found in the construction of the letters, in which the body portions of the letters, entirely up to the boundaries thereof, are formed of clear glass, as at K', and instead of having the letters composed of crystals inserted in the chipped or ground glass portion I fill the clear-glass body portions as full of the jewels as is possible, and in order to facilitate this I preferably employ jewels of different sizes, as clearly shown in Figs. 11 and 13, the smaller sizes of the jewels fitting in between the spaces between the larger ones. These jewels, large and small, are cemented to the clear portion of the glass in the customary

manner shown in the other forms, and the background of the sign is made opaque, the same as in the other forms. With this form the largest possible amount of light consistent with the confining of the illumination to the letters is allowed to pass out of the sign and a greater brilliancy is secured than in the other forms. The large number of jewels in the sign adds to the brilliancy thereof, both by day and night.

As will be readily perceived, my sign is adapted to take the place of the very expensive signs now in use, in which the outlines of the design are formed by incandescent electric-light bulbs; but the expense of operating these is almost prohibitive for certain purposes, whereas the expense of operating my sign is comparatively trifling. My invention forms, with the plate-glass construction described, a sign that is extremely beautiful by day and effective by night and one that can be readily cleaned, as the only portions of it which are exposed are smooth glass, which can be readily wiped off and kept entirely clean. Another advantage of my structure over the incandescent-light sign previously mentioned, constructed with projecting bulbs and any similar form of sign, is the fact that by reason of not having any projecting surfaces to furnish illumination my sign can be read at any angle to it, no matter how acute, whereas with the electric-light sign formed as above indicated several degrees on either side of it are entirely unavailable for reading or seeing the design.

While I have shown and described my improvements as constructed in the form which I at present consider best adapted to carry out the purposes of my invention, it will be understood that it is capable of some modifications and that I do not desire to be limited in the interpretation of the following claims except as may be necessitated by the state of the art.

What I claim, and desire to secure by Letters Patent of the United States, is—

1. In a sign, the combination of the front plate formed of glass or some similar translucent substance, with the thin opaque background placed on the rear side of the front plate and having openings therein, the jewels arranged on the back of said front plate in the openings in said background so as to form a design, a chamber back of said front plate, and a source of illumination in said chamber and in the rear of the jewels, which are arranged so as to have their convex sides extending through said opaque background and into the chamber, substantially as described.

2. In a sign, the combination of the front plate formed of glass or some similar translucent substance, with the thin opaque background placed on the rear side of the front plate and having openings therein, the jewels arranged on the back of said front plate in the openings in said background so as to

form a design, a chamber back of said front plate, with a reflector back of the jewels, and a source of illumination in said chamber interposed between the reflector and the jewels which are arranged so as to have their convex sides extending through said opaque background and into the chamber, substantially as and for the purpose described.

3. In a sign, the combination of the front plate consisting of a sheet of glass having a clear outer surface, and having the jewels arranged on the back thereof to form a design, with a layer of opaque material over the back of said glass, except the portion covered by the jewels, a chamber back of the front plate, and a source of illumination in said chamber and in the rear of the jewels, which are arranged so as to have their convex sides extending through said opaque material and into the chamber, substantially as and for the purpose described.

4. In a sign, the combination of the front plate consisting of a sheet of plate-glass having a clear outer surface, and having the jewels arranged on the back thereof to form a design, with a layer of opaque material over the clear portions of the back of said glass except those covered by the jewels, with a reflector back of the jewels, and a light interposed between the jewels and the reflector, said jewels being arranged so as to have their convex sides extending through said opaque material and

into the chamber, substantially as and for the purpose described.

5. In a sign, the combination of the front plate consisting of a sheet of glass, having a clear outer surface, and having the jewels arranged on the back thereof over clear portions to form portions of a design chipped or etched on said back, with a layer of opaque material over the back of said glass except the portion covered by the design, a chamber back of the front plate, and a source of illumination in said chamber and in the rear of the jewels.

6. In a sign, the combination of the front plate consisting of a sheet of glass having a clear outer surface, and having the jewels arranged on the back thereof over clear portions to form part of a design chipped or etched on said back, with a layer of opaque material over the back of said glass except the portion covered by the design, and another layer of opaque material over the portion of the back of the glass forming the design except that covered by the jewels, the colors of said layers being contrasted, a chamber back of the front plate, and a source of illumination in said chamber and in the rear of the jewels, substantially as described.

SAMUEL EVANS.

Witnesses:

LOUISE E. SERAGE,
HATTIE O. HALVORSON.