



US00RE48922E

(19) **United States**  
(12) **Reissued Patent**  
**Dong et al.**

(10) **Patent Number:** **US RE48,922 E**  
(45) **Date of Reissued Patent:** **Feb. 1, 2022**

(54) **LINEAR LED ILLUMINATION DEVICE WITH IMPROVED COLOR MIXING**

FOREIGN PATENT DOCUMENTS

(71) Applicant: **Lutron Technology Company LLC**,  
Coopersburg, PA (US)

CN 1291282 4/2001  
CN 1396616 2/2003  
(Continued)

(72) Inventors: **Fangxu Dong**, Austin, TX (US); **Craig T. Phillips**, San Marcos, TX (US)

OTHER PUBLICATIONS

(73) Assignee: **Lutron Technology Company LLC**,  
Coopersburg, PA (US)

International Search Report & Written Opinion, PCT/US2010/000219, dated Oct. 12, 2010.

(21) Appl. No.: **16/001,523**

(Continued)

(22) Filed: **Jun. 6, 2018**

*Primary Examiner* — Angela M Lie

**Related U.S. Patent Documents**

(74) *Attorney, Agent, or Firm* — Condo Roccia Koptiw LLP

Reissue of:

(64) Patent No.: **9,360,174**  
Issued: **Jun. 7, 2016**  
Appl. No.: **14/097,339**  
Filed: **Dec. 5, 2013**

(57) **ABSTRACT**

(51) **Int. Cl.**  
**F21V 7/00** (2006.01)  
**F21V 7/04** (2006.01)  
(Continued)

A linear multi-color LED illumination device that produces uniform color throughout the output light beam without the use of excessively large optics or optical losses is disclosed herein. Embodiments for improving color mixing in the linear illumination device include, but are not limited to, a shallow dome encapsulating a plurality of emission LEDs within an emitter module, a unique arrangement of a plurality of such emitter modules in a linear light form factor, and special reflectors designed to improve color mixing between the plurality of emitter modules. In addition to improved color mixing, the illumination device includes a light detector and optical feedback for maintaining precise and uniform color over time and/or with changes in temperature. The light detector is encapsulated within the shallow dome along with the emission LEDs and is positioned to capture the greatest amount of light reflected by the dome from the LED having the shortest emission wavelength.

(52) **U.S. Cl.**  
CPC ..... **H05B 45/22** (2020.01); **F21K 9/62** (2016.08); **F21V 7/0083** (2013.01); **F21V 7/048** (2013.01);  
(Continued)

(58) **Field of Classification Search**  
CPC ..... F21K 9/54; F21V 7/0083; F21V 7/048; F21V 7/06; F21V 21/30; H05B 33/0803; H05B 33/0854; H05B 33/0857  
See application file for complete search history.

(56) **References Cited**

**U.S. PATENT DOCUMENTS**

4,029,976 A 6/1977 Fish et al.  
4,402,090 A 8/1983 Gfeller et al.  
(Continued)

**35 Claims, 12 Drawing Sheets**

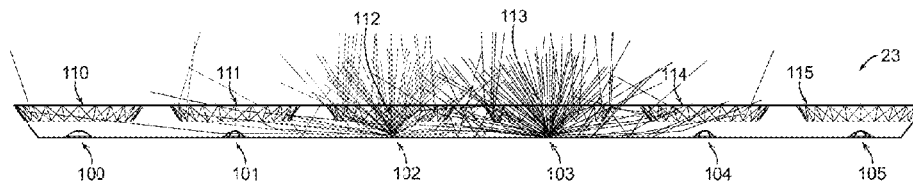

Amended

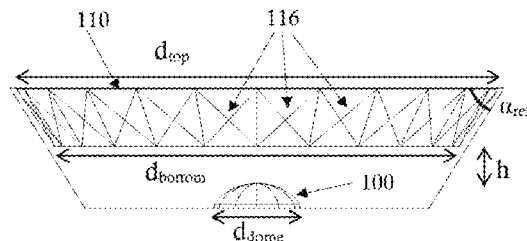

(51)	<b>Int. Cl.</b>								
	<i>F21V 7/06</i>	(2006.01)		6,636,003	B2	10/2003	Rahm et al.		
	<i>F21V 13/04</i>	(2006.01)		6,639,574	B2	10/2003	Scheibe		
	<i>H05B 33/08</i>	(2020.01)		6,664,744	B2	12/2003	Dietz		
	<i>F21K 99/00</i>	(2016.01)		6,692,136	B2	2/2004	Marshall et al.		
	<i>F21V 21/30</i>	(2006.01)		6,741,351	B2	5/2004	Marshall et al.		
	<i>H05B 45/22</i>	(2020.01)		6,753,661	B2	6/2004	Muthu et al.		
	<i>F21K 9/62</i>	(2016.01)		6,788,011	B2	9/2004	Mueller et al.		
	<i>H05B 45/00</i>	(2020.01)		6,806,659	B1	10/2004	Mueller et al.		
	<i>H05B 45/20</i>	(2020.01)		6,831,569	B2	12/2004	Wang et al.		
	<i>H05B 45/10</i>	(2020.01)		6,831,626	B2	12/2004	Nakamura et al.		
	<i>F21Y 105/12</i>	(2016.01)		6,853,150	B2	2/2005	Clauberg et al.		
	<i>F21Y 113/17</i>	(2016.01)		6,879,263	B2	4/2005	Pederson et al.		
	<i>F21Y 103/10</i>	(2016.01)		6,965,205	B2	11/2005	Piepgras et al.		
	<i>F21Y 105/10</i>	(2016.01)		6,969,954	B2	11/2005	Lys		
	<i>F21Y 115/10</i>	(2016.01)		6,975,079	B2	12/2005	Lys et al.		
	<i>F21Y 103/00</i>	(2016.01)		7,006,768	B1	2/2006	Franklin		
				7,014,336	B1	3/2006	Ducharme et al.		
				7,038,399	B2	5/2006	Lys et al.		
				7,046,160	B2	5/2006	Pederson et al.		
				7,072,587	B2	7/2006	Dietz et al.		
				7,088,031	B2	8/2006	Brantner et al.		
(52)	<b>U.S. Cl.</b>			7,119,500	B2	10/2006	Young		
	CPC .....	<i>F21V 7/06</i> (2013.01); <i>F21V 13/04</i>		7,135,824	B2	11/2006	Lys et al.		
		(2013.01); <i>F21V 21/30</i> (2013.01); <i>H05B</i>		7,161,311	B2	1/2007	Mueller et al.		
		<i>45/00</i> (2020.01); <i>H05B 45/10</i> (2020.01);		7,166,966	B2	1/2007	Naugler, Jr. et al.		
		<i>H05B 45/20</i> (2020.01); <i>F21Y 2103/00</i>		7,194,209	B1	3/2007	Robbins et al.		
		(2013.01); <i>F21Y 2103/10</i> (2016.08); <i>F21Y</i>		7,233,115	B2	6/2007	Lys		
		<i>2105/10</i> (2016.08); <i>F21Y 2105/12</i> (2016.08);		7,233,831	B2	6/2007	Blackwell		
		<i>F21Y 2113/17</i> (2016.08); <i>F21Y 2115/10</i>		7,252,408	B2	8/2007	Mazzochette et al.		
		(2016.08)		7,255,458	B2	8/2007	Ashdown		
				7,256,554	B2	8/2007	Lys		
				7,262,559	B2	8/2007	Tripathi et al.		
				7,294,816	B2	11/2007	Ng et al.		
				7,315,139	B1	1/2008	Selvan et al.		
				7,319,298	B2	1/2008	Jungwirth et al.		
				7,329,998	B2	2/2008	Jungwirth		
				7,330,002	B2	2/2008	Joung		
				7,330,662	B2	2/2008	Zimmerman		
				7,352,972	B2	4/2008	Franklin		
				7,358,706	B2	4/2008	Lys		
				7,359,640	B2	4/2008	Onde et al.		
				7,362,320	B2	4/2008	Payne et al.		
				7,372,859	B2	5/2008	Hall et al.		
				7,400,310	B2	7/2008	LeMay		
				7,445,340	B2	11/2008	Conner et al.		
				7,511,695	B2	3/2009	Furukawa et al.		
				7,525,611	B2	4/2009	Zagar et al.		
				7,554,514	B2	6/2009	Nozawa		
				7,573,210	B2	8/2009	Ashdown et al.		
				7,583,901	B2	9/2009	Nakagawa et al.		
				7,606,451	B2	10/2009	Morita		
				7,607,798	B2	10/2009	Panotopoulos		
				7,619,193	B2	11/2009	Deurenberg		
				7,649,527	B2	1/2010	Cho et al.		
				7,659,672	B2	2/2010	Yang		
				7,683,864	B2	3/2010	Lee et al.		
				7,701,151	B2	4/2010	Petrucci et al.		
				7,737,936	B2	6/2010	Daly		
				7,828,479	B1	11/2010	Aslan et al.		
				8,013,538	B2	9/2011	Zampini et al.		
				8,018,135	B2	9/2011	Van De Ven et al.		
				8,040,299	B2	10/2011	Kretz et al.		
				8,044,899	B2	10/2011	Ng et al.		
				8,044,918	B2	10/2011	Choi		
				8,057,072	B2*	11/2011	Takenaka .....	<i>F21K 9/00</i>	
								257/98	
				8,075,182	B2	12/2011	Dai et al.		
				8,076,869	B2	12/2011	Shatford et al.		
				8,159,150	B2	4/2012	Ashdown et al.		
				8,174,197	B2	5/2012	Ghanem et al.		
				8,174,205	B2	5/2012	Myers et al.		
				8,283,876	B2	10/2012	Ji		
				8,287,150	B2*	10/2012	Schaefer .....	<i>F21V 5/007</i>	
								362/237	
				8,299,722	B2	10/2012	Melanson		
				8,362,707	B2	1/2013	Draper et al.		
				8,471,496	B2	6/2013	Knapp		
				8,521,035	B2	8/2013	Knapp et al.		
(56)	<b>References Cited</b>								
	<b>U.S. PATENT DOCUMENTS</b>								
	4,713,841	A	12/1987	Porter et al.					
	4,745,402	A	5/1988	Auerbach					
	4,809,359	A	2/1989	Dockery					
	5,018,057	A	5/1991	Biggs et al.					
	5,103,466	A	4/1992	Bazes					
	5,181,015	A	1/1993	Marshall et al.					
	5,193,201	A	3/1993	Tymes					
	5,218,356	A	6/1993	Knapp					
	5,299,046	A	3/1994	Spaeth et al.					
	5,317,441	A	5/1994	Sidman					
	5,541,759	A	7/1996	Neff et al.					
	5,619,262	A	4/1997	Uno					
	5,657,145	A	8/1997	Smith					
	5,797,085	A	8/1998	Beuk et al.					
	5,905,445	A	5/1999	Gurney et al.					
	6,016,038	A	1/2000	Mueller et al.					
	6,067,595	A	5/2000	Lindenstruth					
	6,069,929	A	5/2000	Yabe et al.					
	6,084,231	A	7/2000	Popat					
	6,094,014	A	7/2000	Bucks et al.					
	6,094,340	A	7/2000	Min					
	6,108,114	A	8/2000	Gilliland et al.					
	6,127,783	A	10/2000	Pashley et al.					
	6,147,458	A	11/2000	Bucks et al.					
	6,150,774	A	11/2000	Mueller et al.					
	6,234,645	B1	5/2001	Borner et al.					
	6,234,648	B1	5/2001	Borner et al.					
	6,250,774	B1	6/2001	Begemann et al.					
	6,333,605	B1	12/2001	Grouev et al.					
	6,344,641	B1	2/2002	Blalock et al.					
	6,356,774	B1	3/2002	Bernstein et al.					
	6,359,712	B1	3/2002	Kamitani					
	6,384,545	B1	5/2002	Lau					
	6,396,815	B1	5/2002	Greaves et al.					
	6,414,661	B1	7/2002	Shen et al.					
	6,441,558	B1	8/2002	Muthu et al.					
	6,448,550	B1	9/2002	Nishimura					
	6,495,964	B1	12/2002	Muthu et al.					
	6,498,440	B2	12/2002	Stam et al.					
	6,513,949	B1	2/2003	Marshall et al.					
	6,577,512	B2	6/2003	Tripathi et al.					
	6,617,795	B2	9/2003	Bruning					

(56)		References Cited					
		U.S. PATENT DOCUMENTS					
				2007/0109239	A1	5/2007	den Boer et al.
				2007/0132592	A1	6/2007	Stewart et al.
				2007/0139957	A1	6/2007	Haim et al.
				2007/0248180	A1	10/2007	Bowman et al.
8,546,842	B2 *	10/2013	Higuma ..... H01L 33/641 257/100	2007/0254694	A1	11/2007	Nakagwa et al.
8,556,438	B2	10/2013	McKenzie et al.	2007/0268429	A1	11/2007	So
8,569,974	B2	10/2013	Chobot	2007/0279346	A1	12/2007	den Boer et al.
8,595,748	B1	11/2013	Haggerty et al.	2008/0061717	A1	3/2008	Bogner et al.
8,633,655	B2	1/2014	Kao et al.	2008/0078733	A1 *	4/2008	Nearman ..... G09F 9/33 211/189
8,643,043	B2 *	2/2014	Shimizu ..... F21S 8/04 257/88	2008/0107029	A1	5/2008	Hall et al.
8,646,940	B2 *	2/2014	Jang ..... F21V 7/0008 362/235	2008/0120559	A1	5/2008	Yee
8,653,758	B2	2/2014	Radermacher et al.	2008/0136334	A1	6/2008	Robinson et al.
8,657,463	B2 *	2/2014	Lichten ..... F21S 8/063 362/231	2008/0136770	A1	6/2008	Peker et al.
8,680,787	B2	3/2014	Veskovic	2008/0136771	A1	6/2008	Chen et al.
8,704,666	B2	4/2014	Baker, Jr.	2008/0150864	A1	6/2008	Bergquist
8,721,115	B2 *	5/2014	Ing ..... G09F 13/14 362/241	2008/0186898	A1	8/2008	Petite
8,749,172	B2	6/2014	Knapp	2008/0222367	A1	9/2008	Co
8,773,032	B2	7/2014	May et al.	2008/0235418	A1	9/2008	Werthen et al.
8,791,647	B2	7/2014	Kesterson et al.	2008/0253766	A1	10/2008	Yu et al.
8,807,792	B2 *	8/2014	Cho ..... F21V 7/0058 362/235	2008/0265799	A1	10/2008	Sibert
8,816,600	B2	8/2014	Elder	2008/0296589	A1	12/2008	Speier et al.
8,820,962	B2 *	9/2014	Kang ..... F21V 3/00 362/236	2008/0297070	A1	12/2008	Kuenzler et al.
8,911,160	B2 *	12/2014	Seo ..... G02F 1/133603 359/642	2008/0304833	A1	12/2008	Zheng
9,004,724	B2 *	4/2015	Gao ..... F21V 3/00 313/113	2008/0309255	A1	12/2008	Myers et al.
9,074,751	B2 *	7/2015	Son ..... F21V 14/006	2008/0317475	A1	12/2008	Pederson et al.
9,247,605	B1	1/2016	Ho et al.	2009/0026978	A1	1/2009	Robinson
9,557,214	B2	1/2017	Ho et al.	2009/0040154	A1	2/2009	Scheibe
9,578,724	B1	2/2017	Knapp et al.	2009/0049295	A1	2/2009	Erickson et al.
9,651,632	B1	5/2017	Knapp et al.	2009/0051496	A1	2/2009	Pahlavan et al.
9,736,903	B2	8/2017	Lewis et al.	2009/0121238	A1	5/2009	Peck
9,769,899	B2	9/2017	Ho et al.	2009/0171571	A1	7/2009	Son et al.
2001/0020123	A1	9/2001	Diab et al.	2009/0174331	A1	7/2009	Tanaka
2001/0030668	A1	10/2001	Erten et al.	2009/0196282	A1	8/2009	Fellman et al.
2002/0014643	A1	2/2002	Kubo et al.	2009/0245101	A1	10/2009	Kwon et al.
2002/0033981	A1	3/2002	Keller et al.	2009/0278789	A1	11/2009	Declercq et al.
2002/0047624	A1	4/2002	Stam et al.	2009/0284511	A1	11/2009	Takasugi et al.
2002/0049933	A1	4/2002	Nyu	2009/0303972	A1	12/2009	Flammer, III et al.
2002/0134908	A1	9/2002	Johnson	2010/0005533	A1	1/2010	Shamir
2002/0138850	A1	9/2002	Basil et al.	2010/0054748	A1	3/2010	Sato
2002/0171608	A1	11/2002	Kanai et al.	2010/0061734	A1	3/2010	Knapp
2003/0103413	A1	6/2003	Jacobi, Jr. et al.	2010/0096447	A1	4/2010	Kwon et al.
2003/0122749	A1	7/2003	Booth, Jr. et al.	2010/0134021	A1	6/2010	Ayres
2003/0133491	A1	7/2003	Shih	2010/0134024	A1	6/2010	Brandes
2003/0179721	A1	9/2003	Shurmantine et al.	2010/0141159	A1	6/2010	Shiu et al.
2004/0044709	A1	3/2004	Cabrera et al.	2010/0182294	A1	7/2010	Roshan et al.
2004/0052076	A1	3/2004	Mueller et al.	2010/0188443	A1	7/2010	Lewis et al.
2004/0052299	A1	3/2004	Jay et al.	2010/0188972	A1	7/2010	Knapp
2004/0101312	A1	5/2004	Cabrera	2010/0194299	A1	8/2010	Ye et al.
2004/0136682	A1	7/2004	Watanabe	2010/0213856	A1	8/2010	Mizusako
2004/0201793	A1	10/2004	Anandan et al.	2010/0272437	A1	10/2010	Yoon et al.
2004/0220922	A1	11/2004	Lovison et al.	2010/0301777	A1	12/2010	Kraemer
2004/0257311	A1	12/2004	Kanai et al.	2010/0327764	A1	12/2010	Knapp
2005/0004727	A1	1/2005	Remboski et al.	2011/0031894	A1	2/2011	Van De Ven
2005/0030203	A1	2/2005	Sharp et al.	2011/0044343	A1	2/2011	Sethuram et al.
2005/0030267	A1	2/2005	Tanghe et al.	2011/0052214	A1	3/2011	Shimada et al.
2005/0053378	A1	3/2005	Stanchfield et al.	2011/0062874	A1	3/2011	Knapp
2005/0077838	A1	4/2005	Blumel	2011/0063214	A1	3/2011	Knapp
2005/0110777	A1	5/2005	Geaghan et al.	2011/0063268	A1	3/2011	Knapp
2005/0169643	A1	8/2005	Franklin	2011/0068699	A1	3/2011	Knapp
2005/0200292	A1	9/2005	Naugler, Jr. et al.	2011/0069094	A1	3/2011	Knapp
2005/0207157	A1	9/2005	Tani	2011/0069960	A1	3/2011	Knapp et al.
2005/0242742	A1	11/2005	Cheang et al.	2011/0133654	A1	6/2011	McKenzie et al.
2005/0265731	A1	12/2005	Keum et al.	2011/0148315	A1	6/2011	Van Der Veen et al.
2006/0145887	A1	7/2006	McMahon	2011/0150028	A1	6/2011	Nguyen et al.
2006/0164291	A1	7/2006	Gunnarsson	2011/0248640	A1	10/2011	Welten
2006/0198463	A1	9/2006	Godin	2011/0253915	A1	10/2011	Knapp
2006/0220990	A1	10/2006	Coushaine et al.	2011/0299854	A1	12/2011	Jonsson et al.
2006/0227085	A1	10/2006	Boldt, Jr. et al.	2011/0309754	A1	12/2011	Ashdown et al.
2007/0040512	A1	2/2007	Jungwirth et al.	2012/0056545	A1	3/2012	Radermacher et al.
				2012/0153839	A1	6/2012	Farley et al.
				2012/0229032	A1	9/2012	Van De Ven et al.
				2012/0299481	A1	11/2012	Stevens
				2012/0306370	A1	12/2012	Van De Ven et al.
				2013/0016978	A1	1/2013	Son et al.
				2013/0088522	A1	4/2013	Gettemy et al.
				2013/0201690	A1 *	8/2013	Vissenberg et al. .... E04B 9/34 362/296.07
				2013/0257314	A1	10/2013	Alvord et al.

(56)

**References Cited**

## U.S. PATENT DOCUMENTS

2013/0293147 A1 11/2013 Rogers et al.  
 2014/0028377 A1 1/2014 Rosik et al.  
 2015/0022110 A1 1/2015 Sisto

## FOREIGN PATENT DOCUMENTS

CN	1573881	2/2005
CN	1650673	8/2005
CN	1849707	10/2006
CN	101083866	12/2007
CN	101150904	3/2008
CN	101331798	12/2008
CN	101458067	6/2009
DE	102008016095 A1	10/2009
DE	102008064397 A1	6/2010
EP	0196347	10/1986
EP	0456462	11/1991
EP	2273851	1/2011
EP	2426405 A2	3/2012
EP	2573451 A1	3/2013
GB	2307577	5/1997
JP	06-302384	10/1994
JP	08-201472	8/1996
JP	11-025822	1/1999
JP	2001-514432	9/2001
JP	2004-325643	11/2004
JP	2005-539247	12/2005
JP	2006-260927	9/2006
JP	2007-266974	10/2007
JP	2007-267037	10/2007
JP	2008-507150	3/2008
JP	2008-300152	12/2008
JP	2009-134877	6/2009
WO	00/37904	6/2000
WO	03/075617	9/2003
WO	2005/024898	3/2005
WO	2006/033031 A2	3/2006
WO	2007/069149	6/2007
WO	2008/065607	6/2008
WO	2008/129453	10/2008
WO	2010/124315	11/2010
WO	2012/005771	1/2012
WO	2012/042429	4/2012
WO	2013/142437	9/2013

## OTHER PUBLICATIONS

International Search Report & Written Opinion, PCT/US2010/002171, dated Nov. 24, 2010.  
 International Search Report & Written Opinion, PCT/US2010/004953, dated Mar. 22, 2010.  
 International Search Report & Written Opinion, PCT/US2010/001919, dated Feb. 24, 2011.  
 U.S. Appl. No. 12/924,628, filed Sep. 30, 2010.  
 Office Action dated May 12, 2001 for U.S. Appl. No. 12/360,467.  
 Final Office Action dated Nov. 28, 2011 for U.S. Appl. No. 12/360,467.  
 Notice of Allowance dated Jan. 20, 2012 for U.S. Appl. No. 12/360,467.  
 Office Action dated Feb. 1, 2012 for U.S. Appl. No. 12/584,143.  
 Final Office Action dated Sep. 12, 2012 for U.S. Appl. No. 12/584,143.  
 Office Action dated Aug. 2, 2012 for U.S. Appl. No. 12/806,114.  
 Office Action dated Oct. 2, 2012 for U.S. Appl. No. 12/806,117.  
 Office Action dated Jul. 11, 2012 for U.S. Appl. No. 12/806,121.  
 Final Office Action dated Oct. 11, 2012 for U.S. Appl. No. 12/806,121.  
 Office Action dated Dec. 17, 2012 for U.S. Appl. No. 12/806,118.  
 Office Action dated Oct. 9, 2012 for U.S. Appl. No. 12/806,126.  
 Office Action dated Jul. 10, 2012 for U.S. Appl. No. 12/806,113.  
 Notice of Allowance dated Oct. 15, 2012 for U.S. Appl. No. 12/806,113.

International Search Report & Written Opinion dated Sep. 19, 2012 for PCT/US2012/045392.  
 Partial International Search Report dated Nov. 16, 2012 for PCT/US2012/052774.  
 Office Action dated Nov. 4, 2013 for CN Application No. 201080032373.7.  
 Office Action dated Dec. 4, 2013 for U.S. Appl. No. 12/803,805.  
 Notice of Allowance dated Jan. 28, 2014 for U.S. Appl. No. 13/178,686.  
 Notice of Allowance dated Feb. 21, 2014 for U.S. Appl. No. 12/806,118.  
 Office Action dated Apr. 22, 2014 for U.S. Appl. No. 12/806,114.  
 International Search Report & Written Opinion for PCT/US2012/052774 dated Feb. 4, 2013.  
 Notice of Allowance dated Feb. 4, 2013 for U.S. Appl. No. 12/809,113.  
 Notice of Allowance dated Feb. 25, 2013 for U.S. Appl. No. 12/806,121.  
 Notice of Allowance dated May 3, 2013 for U.S. Appl. No. 12/806,126.  
 International Search Report & Written Opinion, PCT/US2013/027157, dated May 16, 2013.  
 Office Action dated Jun. 10, 2013 for U.S. Appl. No. 12/924,628.  
 Office Action dated Jun. 27, 2013 for U.S. Appl. No. 13/178,686.  
 Final Office Action dated Jul. 9, 2013 for U.S. Appl. No. 12/806,118.  
 Final Office Action dated Jun. 14, 2013 for U.S. Appl. No. 12/806,117.  
 Johnson, "Visible Light Communications," CTC Tech Brief, Nov. 2009, 2 pages.  
 Chonko, "Use Forward Voltage Drop to Measure Junction Temperature," © 2013 Penton Media, Inc., 5 pages.  
 Office Action dated Oct. 24, 2013 for U.S. Appl. No. 12/806,117.  
 Notice of Allowance dated Oct. 31, 2013 for U.S. Appl. No. 12/924,628.  
 Office Action dated Nov. 12, 2013 for U.S. Appl. No. 13/231,077.  
 Final Office Action dated Jun. 18, 2014 for U.S. Appl. No. 13/231,077.  
 Notice of Allowance dated Aug. 21, 2014 for U.S. Appl. No. 12/584,143.  
 Office Action dated Jun. 23, 2014 for U.S. Appl. No. 12/806,117.  
 Office Action dated Sep. 10, 2014 for U.S. Appl. No. 12/803,805.  
 Office Action dated Jan. 28, 2015 for U.S. Appl. No. 12/806,117.  
 Office Action dated Feb. 2, 2015 for CN Application 201080035731.  
 Office Action dated Jul. 1, 2014 for JP Application 2012-520587.  
 Office Action dated Feb. 17, 2015 for JP Application 2012-520587.  
 Office Action dated Mar. 11, 2014 for JP Application 2012-523605.  
 Office Action dated Sep. 24, 2014 for JP Application 2012-523605.  
 Office Action dated Mar. 25, 2015 for U.S. Appl. No. 14/305,472.  
 Notice of Allowance dated Mar. 30, 2015 for U.S. Appl. No. 14/097,355.  
 Office Action dated Apr. 8, 2015 for U.S. Appl. No. 14/305,456.  
 Notice of Allowance dated May 22, 2015 for U.S. Appl. No. 14/510,212.  
 Office Action dated May 27, 2015 for U.S. Appl. No. 12/806,117.  
 Partial International Search Report dated Mar. 27, 2015 for PCT/US2014/068556.  
 International Search Report & Written Opinion for PCT/US2014/068556 dated Jun. 22, 2015.  
 Final Office Action for U.S. Appl. No. 12/803,805 dated Jun. 23, 2015.  
 Office Action for U.S. Appl. No. 13/970,964 dated Jun. 29, 2015.  
 Office Action for U.S. Appl. No. 14/510,243 dated Jul. 28, 2015.  
 Office Action for U.S. Appl. No. 14/510,283 dated Jul. 29, 2015.  
 Office Action for U.S. Appl. No. 14/510,266 dated Jul. 31, 2015.  
 Office Action for U.S. Appl. No. 13/970,990 dated Aug. 20, 2015.  
 Partial International Search Report for PCT/US2015/037660 dated Aug. 21, 2015.  
 Final Office Action for U.S. Appl. No. 13/773,322 dated Sep. 2, 2015.  
 Notice of Allowance for U.S. Appl. No. 13/970,944 dated Sep. 11, 2015.  
 Notice of Allowance for U.S. Appl. No. 14/604,886 dated Sep. 25, 2015.  
 Notice of Allowance for U.S. Appl. No. 14/604,881 dated Oct. 9, 2015.

(56)

**References Cited**

## OTHER PUBLICATIONS

International Search Report & Written Opinion for PCT/US2015/037660 dated Oct. 28, 2015.

Office Action for U.S. Appl. No. 14/573,207 dated Nov. 4, 2015.

Notice of Allowance for U.S. Appl. No. 14/510,243 dated Nov. 6, 2015.

Notice of Allowance for U.S. Appl. No. 12/806,117 dated Nov. 18, 2015.

Partial International Search Report for PCT/US2015/045252 dated Nov. 18, 2015.

Office Action dated Mar. 6, 2015 for U.S. Appl. No. 13/733,322.

Extended European Search Report for EP Application EP Application 21152323.8, dated Jul. 26, 2021, 8 pages.

Office Action for U.S. Appl. No. 13/970,990 mailed Aug. 20, 2015.

Partial International Search Report for PCT/US2015/037660 mailed Aug. 21, 2015.

Final Office Action for U.S. Appl. No. 13/773,322 mailed Sep. 2, 2015.

Notice of Allowance for U.S. Appl. No. 13/970,944 mailed Sep. 11, 2015.

Notice of Allowance for U.S. Appl. No. 14/604,886 mailed Sep. 25, 2015.

Notice of Allowance for U.S. Appl. No. 14/604,881 mailed Oct. 9, 2015.

Office Action mailed Mar. 11, 2014 for JP Application 2012-523605.

Office Action mailed Sep. 24, 2014 for JP Application 2012-523605.

Office Action mailed Mar. 25, 2015 for U.S. Appl. No. 14/305,472.

Notice of Allowance mailed Mar. 30, 2015 for U.S. Appl. No. 14/097,355.

Office Action mailed Apr. 8, 2015 for U.S. Appl. No. 14/305,456.

Notice of Allowance mailed May 22, 2015 for U.S. Appl. No. 14/510,212.

Office Action mailed May 27, 2015 for U.S. Appl. No. 12/806,117.

Partial International Search Report mailed Mar. 27, 2015 for PCT/US2014/068556.

Office Action mailed Apr. 22, 2014 for U.S. Appl. No. 12/806,114.

Final Office Action mailed Jun. 18, 2014 for U.S. Appl. No. 13/231,077.

Office Action mailed Jun. 23, 2014 for U.S. Appl. No. 12/806,117.

"LED Fundamentals, How to Read a Datasheet (Part 2 of 2) Characteristic Curves, Dimensions and Packaging," Aug. 19, 2011, OSRAM Opto Semiconductors, 17 pages.

International Search Report & Written Opinion for PCT/US2014/068556 mailed Jun. 22, 2015.

Final Office Action for U.S. Appl. No. 12/803,805 mailed Jun. 23, 2015.

Office Action for U.S. Appl. No. 13/970,964 mailed Jun. 29, 2015.

Office Action for U.S. Appl. No. 14/510,243 mailed Jul. 28, 2015.

Office Action for U.S. Appl. No. 14/510,283 mailed Jul. 29, 2015.

Office Action for U.S. Appl. No. 14/510,266 mailed Jul. 31, 2015.

Notice of Allowance mailed Aug. 21, 2014 for U.S. Appl. No. 12/584,143.

Office Action mailed Sep. 10, 2014 for U.S. Appl. No. 12/803,805.

"Color Management of a Red, Green, and Blue LED Combinational Light Source," Avago Technologies, Mar. 2010, pp. 1-8.

Final Office Action mailed Jan. 28, 2015 for U.S. Appl. No. 12/806,117.

Office Action mailed Mar. 6, 2015 for U.S. Appl. No. 13/773,322.

Office Action mailed Feb. 2, 2015 for CN Application 201080035731.X.

Office Action mailed Jul. 1, 2014 for JP Application 2012-520587.

Office Action mailed Feb. 17, 2015 for JP Application 2012-520587.

Hall et al., "Jet Engine Control Using Ethernet with a BRAIN (Postprint)," AIAA/ASME/SAE/ASEE Joint Propulsion Conference and Exhibition, Jul. 2008, pp. 1-18.

Kebemou, "A Partitioning-Centric Approach for the Modeling and the Methodical Design of Automotive Embedded System Architectures," Dissertation of Technical University of Berlin, 2008, 176 pages.

O'Brien et al., "Visible Light Communications and Other Developments in Optical Wireless," Wireless World Research Forum, 2006, 26 pages.

Zalewski et al., "Safety Issues in Avionics and Automotive Databases," IFAC World Congress, Jul. 2005, 6 pages.

"Visible Light Communication: Tutorial," Project IEEE P802.15 Working Group for Wireless Personal Area Networks (WPANs), Mar. 2008.

Johnson, "Visible Light Communications," CTC Tech Brief, Nov. 2009, 2 pages.

Chonko, "Use Forward Voltage Drop to Measure Junction Temperature," Dec. 2005, (c) 2013 Penton Media, Inc., 5 pages.

International Search Report & Written Opinion, PCT/US2010/000219, mailed Oct. 12, 2010.

Notice of Allowance mailed Feb. 4, 2013 for U.S. Appl. No. 12/806,113.

Final Office Action mailed Jun. 14, 2013 for U.S. Appl. No. 12/806,117.

Office Action mailed Dec. 4, 2013 for U.S. Appl. No. 12/803,805.

Office Action mailed Nov. 4, 2013 for CN Application No. 201080032373.7.

Notice of Allowance mailed Jan. 28, 2014 for U.S. Appl. No. 13/178,686.

Notice of Allowance mailed Feb. 21, 2014 for U.S. Appl. No. 12/806,118.

Bouchet et al., "Visible-light communication system enabling 73 Mb/s data streaming," IEEE Globecom Workshop on Optical Wireless Communications, 2010, pp. 1042-1046.

International Search Report & Written Opinion for PCT/US2015/037660 mailed Oct. 28, 2015.

Office Action for U.S. Appl. No. 14/573,207 mailed Nov. 4, 2015.

Notice of Allowance for U.S. Appl. No. 14/510,243 mailed Nov. 6, 2015.

Notice of Allowance for U.S. Appl. No. 12/806,117 mailed Nov. 18, 2015.

Partial International Search Report for PCT/US2015/045252 mailed Nov. 18, 2015.

\* cited by examiner

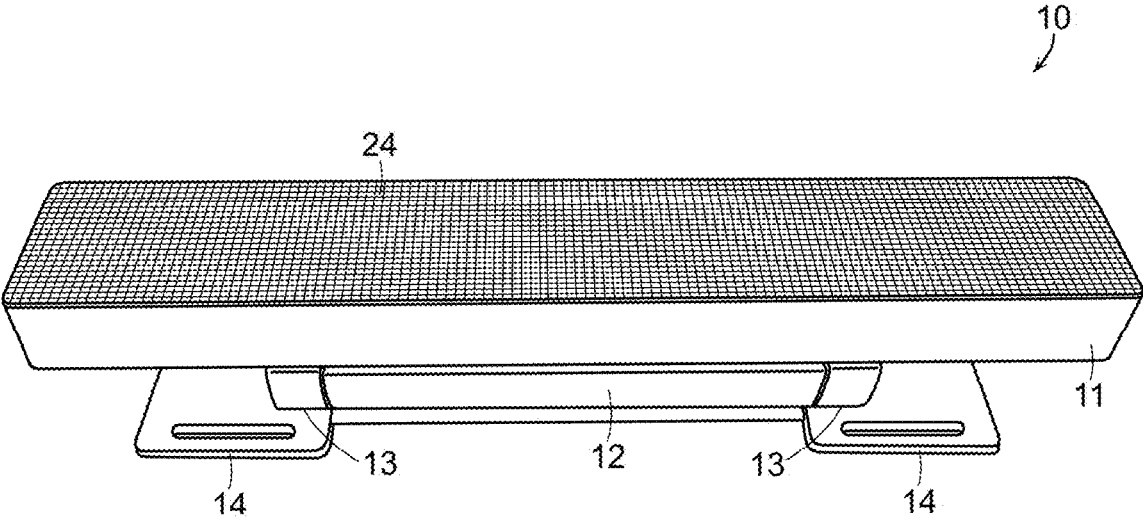

FIG. 1

Amended

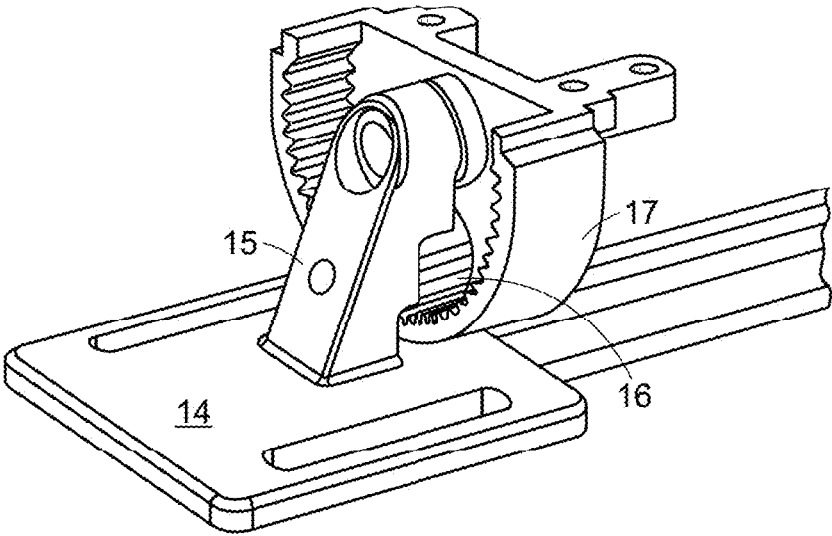

FIG. 2

Amended

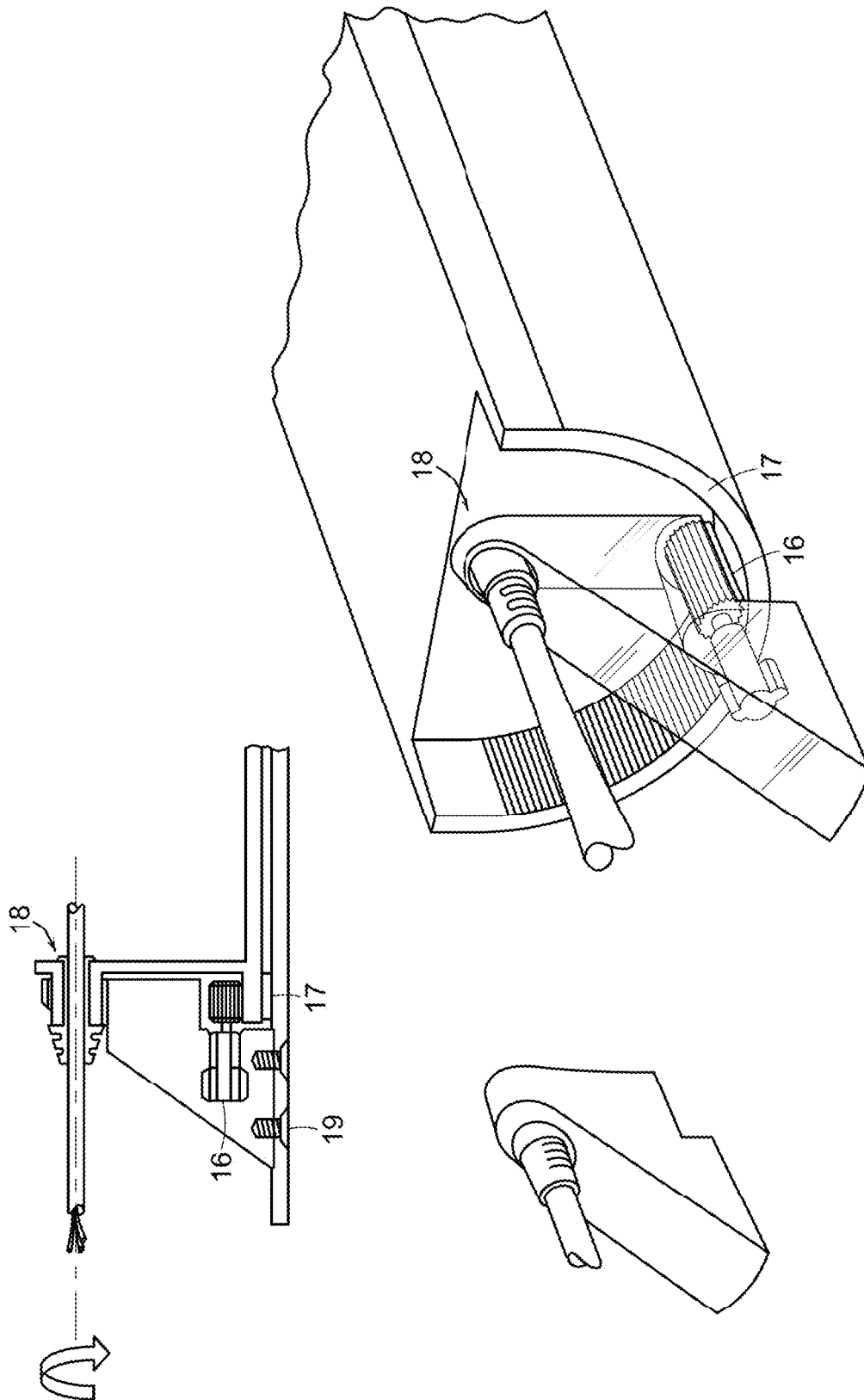

FIG. 3

Amended

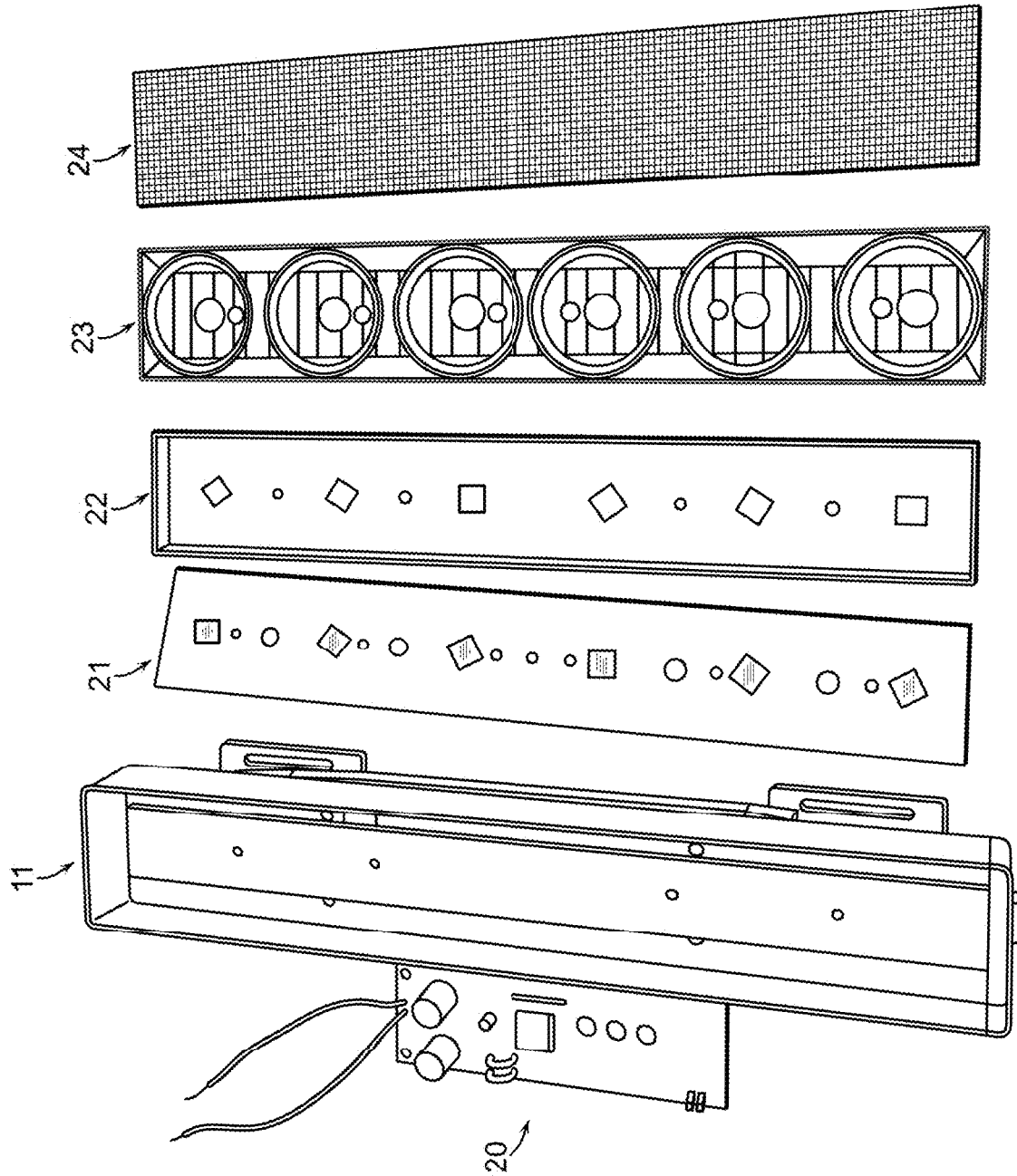

FIG. 4

Amended

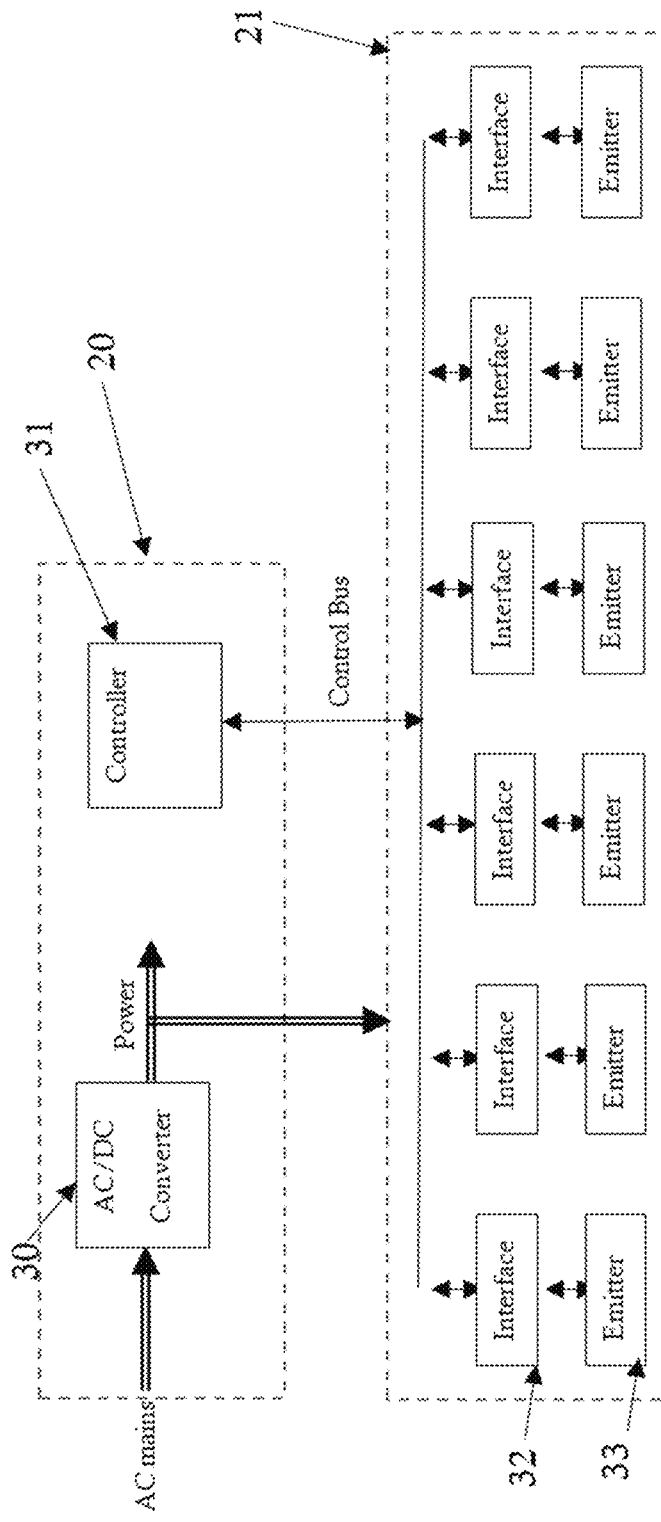

Fig. 5

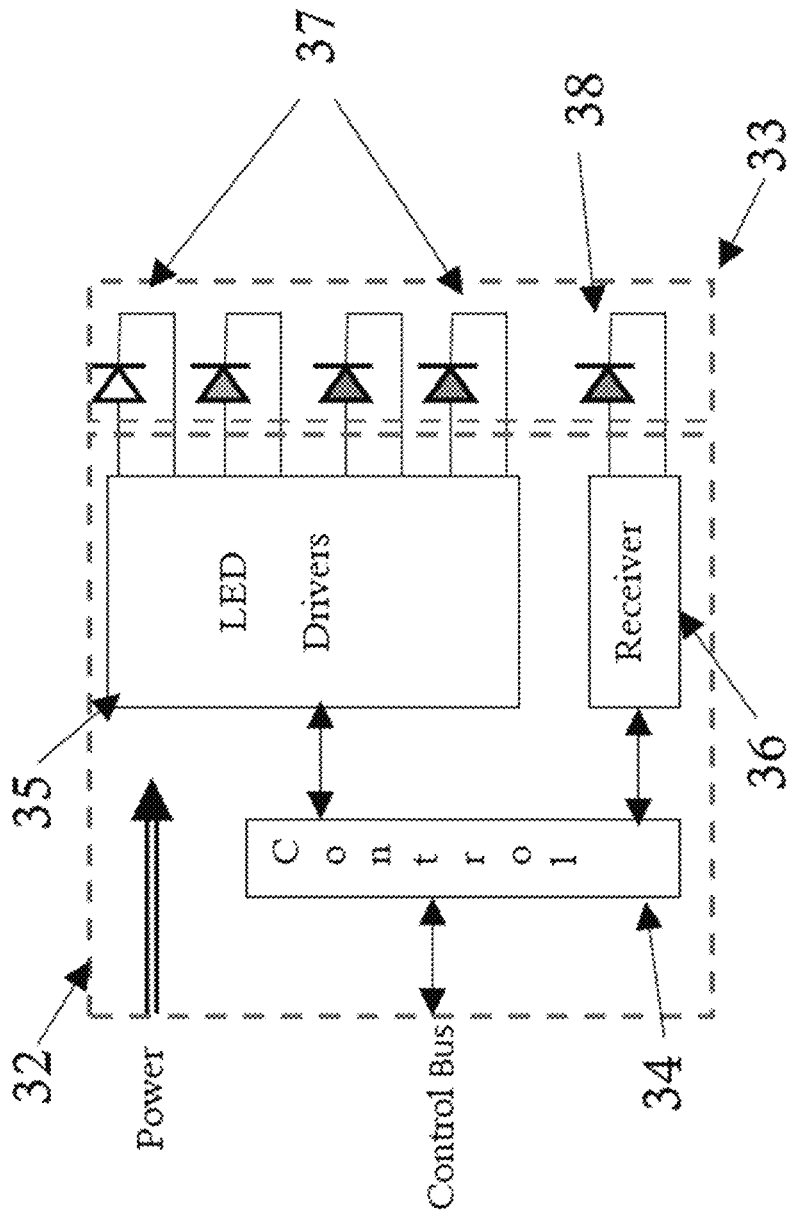

Fig. 6

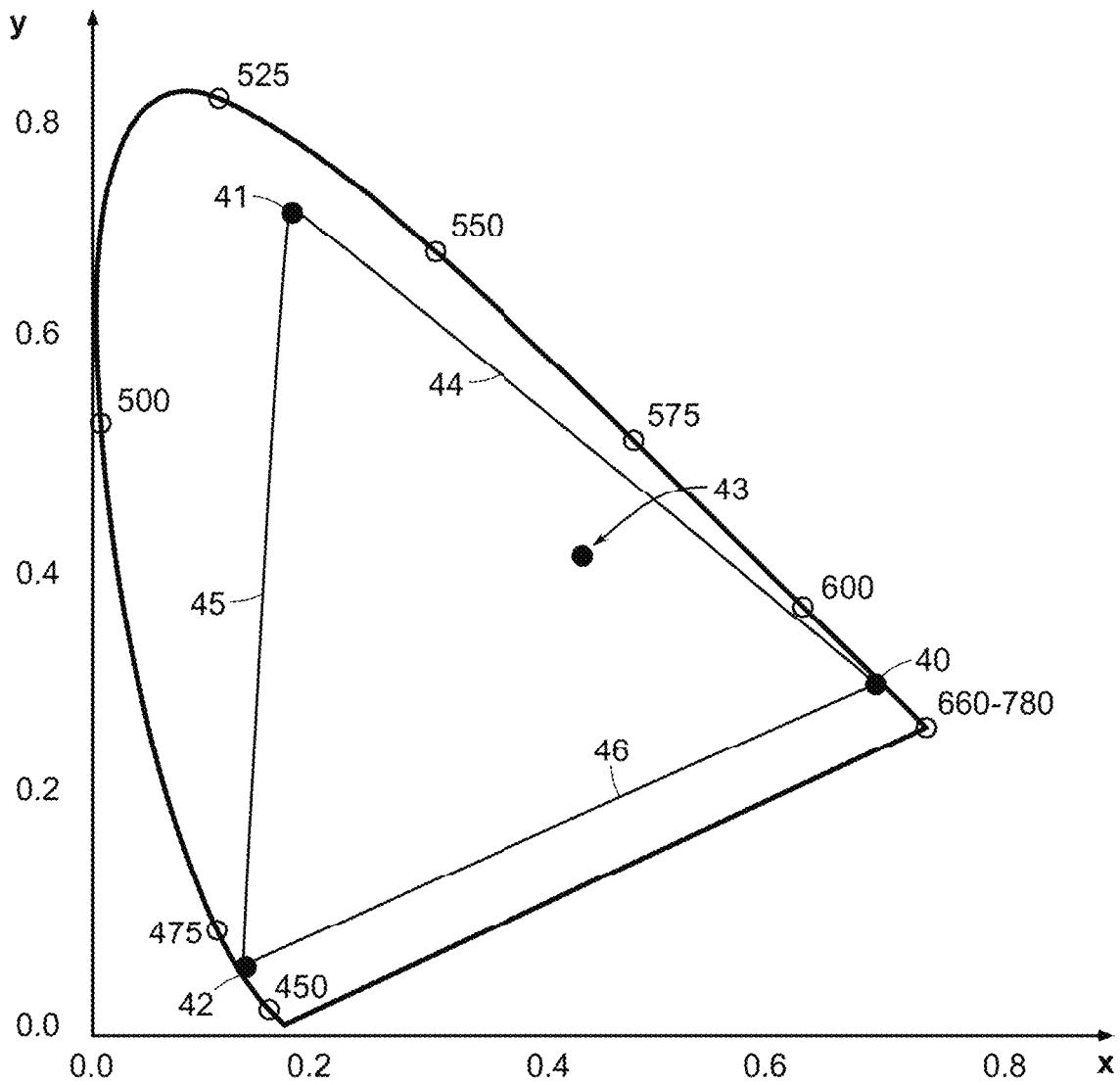

FIG. 7

Amended

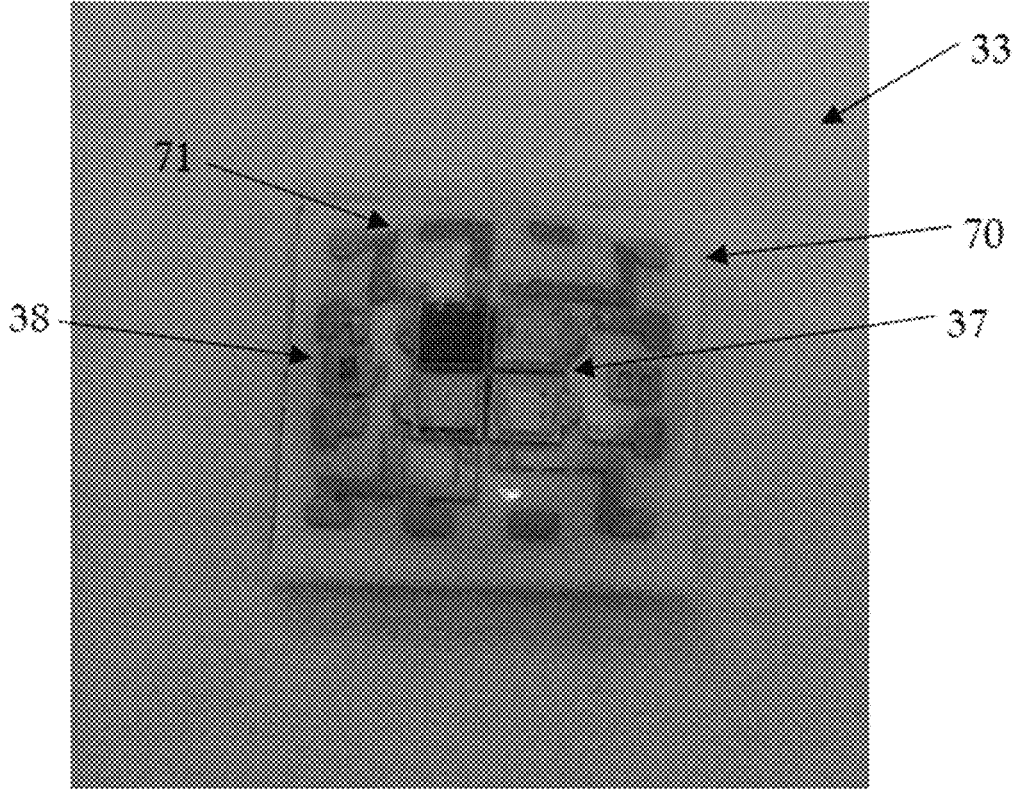

Fig. 8

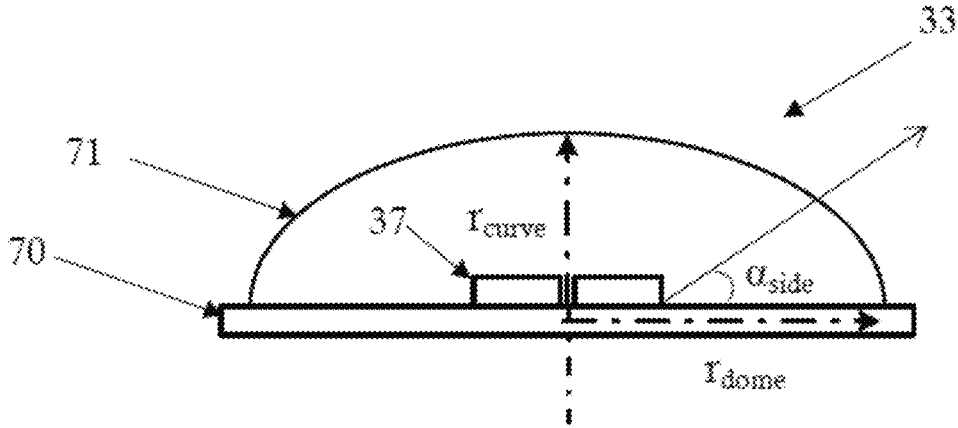

Fig. 9

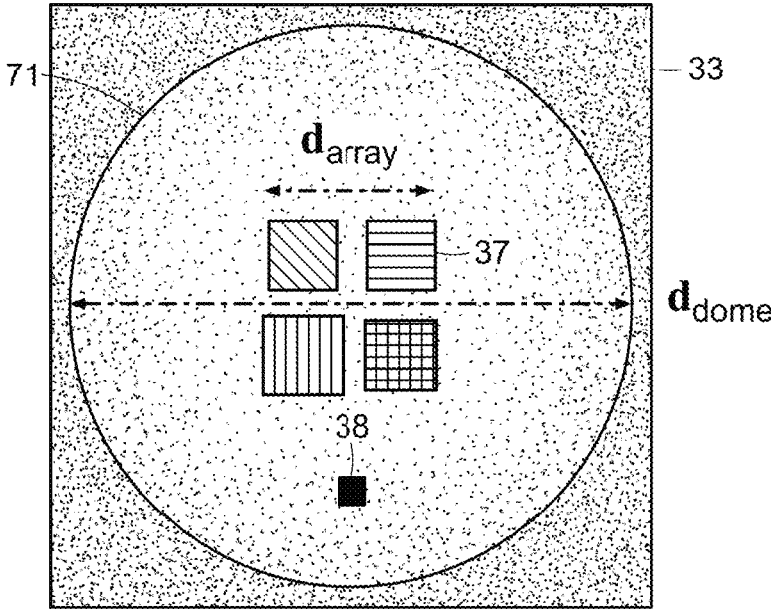

FIG. 10A

Amended

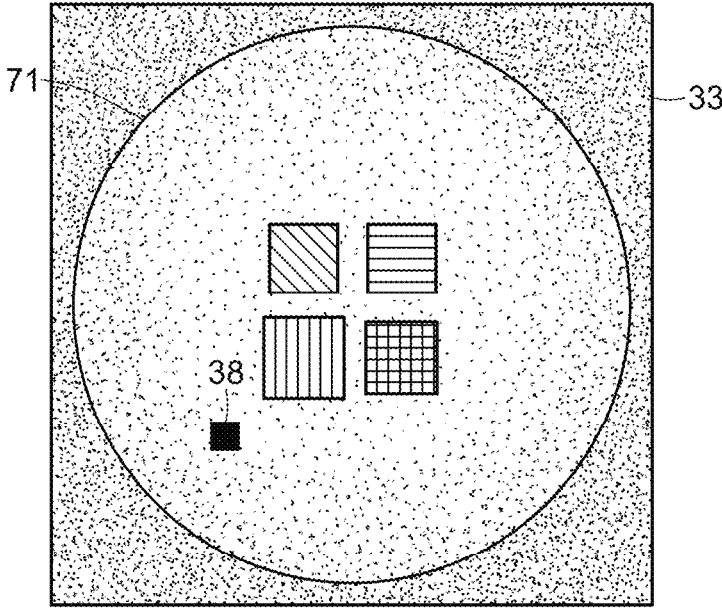

FIG. 10B

Amended

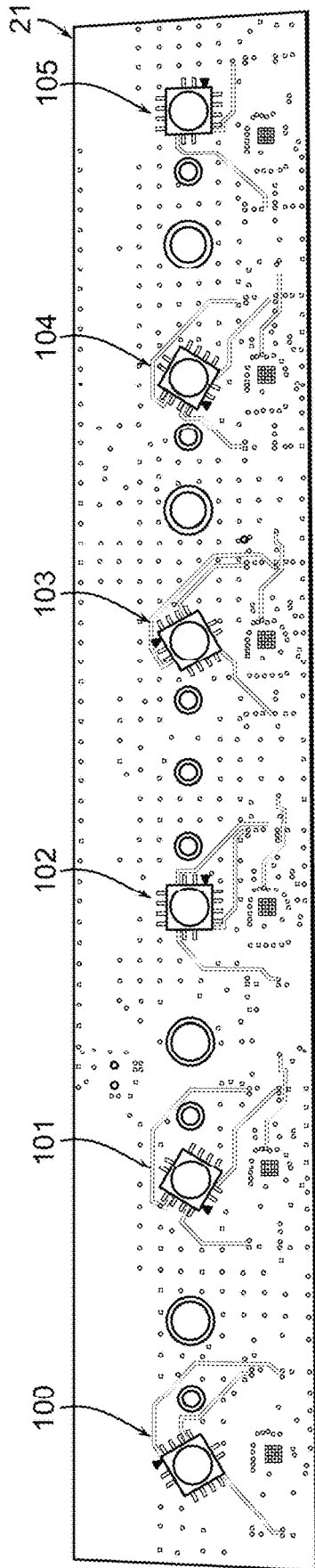

FIG. 11

Amended

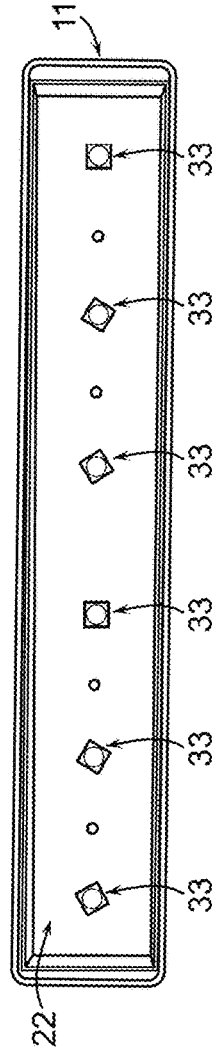

FIG. 12

Amended

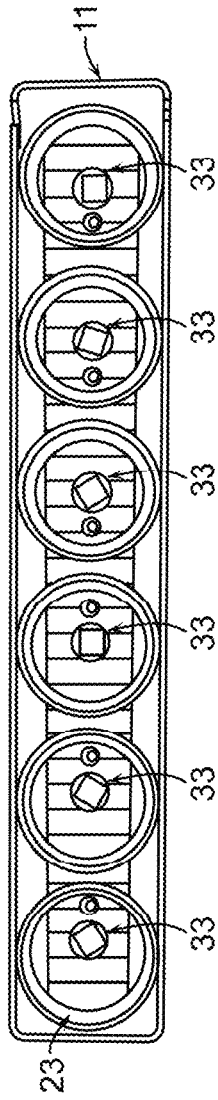

FIG. 13

Amended

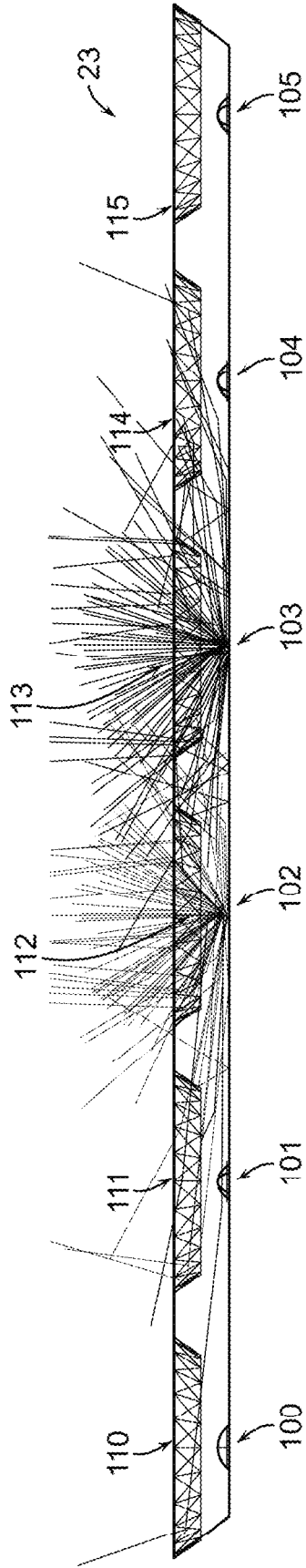

FIG. 14

Amended

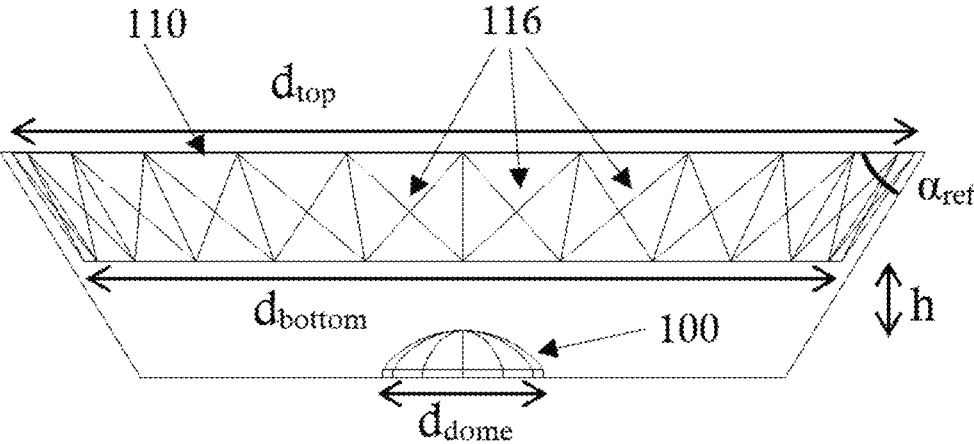

Fig. 15

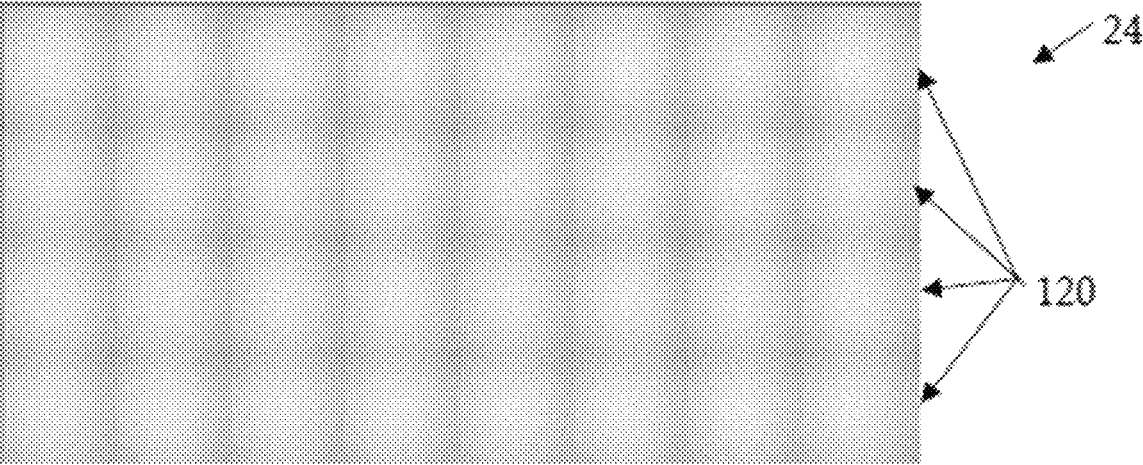

Fig. 16

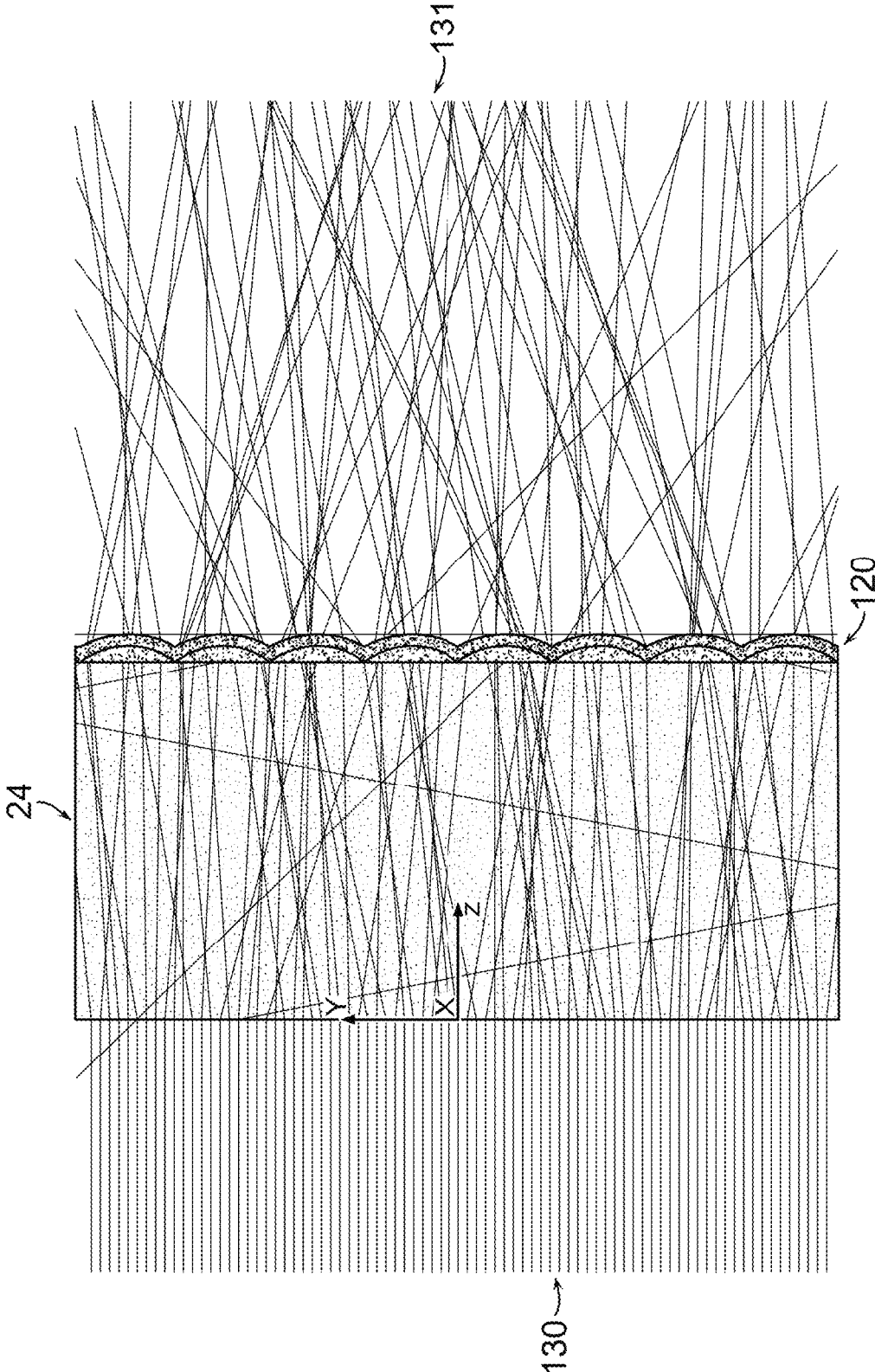

FIG. 17

Amended

## LINEAR LED ILLUMINATION DEVICE WITH IMPROVED COLOR MIXING

**Matter enclosed in heavy brackets [ ] appears in the original patent but forms no part of this reissue specification; matter printed in italics indicates the additions made by reissue; a claim printed with strikethrough indicates that the claim was canceled, disclaimed, or held invalid by a prior post-patent action or proceeding.**

### CROSS-REFERENCE TO RELATED APPLICATIONS

*The present application is a reissue of U.S. Pat. No. 9,360,174, issued on Jun. 7, 2016 from U.S. application Ser. No. 14/097,339, filed Dec. 5, 2013, which is hereby incorporated by reference herein in its entirety.*

### RELATED APPLICATIONS

This application is related to the following applications: U.S. patent application Ser. No. 14/097,355, now U.S. Pat. No. 9,146,028; U.S. patent application Ser. Nos. 13/970,944; now issued as U.S. Pat. No. 9,237,620; 13/970,964; 13/970,990; 12/803,805; and 12/806,118 now issued as U.S. Pat. No. 8,772,336; each of which is hereby incorporated by reference in its entirety.

### BACKGROUND

#### 1. Field of the Invention

The invention relates to the addition of color mixing optics and optical feedback to produce uniform color throughout the output light beam of a multi-color linear LED illumination device.

#### 2. Description of Related Art

Multi-color linear LED illumination devices (also referred to herein as lights, luminaires or lamps) have been commercially available for many years. Typical applications for linear LED illumination devices include wall washing in which a chain of lights attempt to uniformly illuminate a large portion of a wall, and cove lighting in which a chain of lights typically illuminates a large portion of a ceiling. Multi-color linear LED lights often comprise red, green, and blue LEDs, however, some products use some combination of red, green, blue, white, and amber LEDs.

A multi-color linear LED illumination device typically includes one or more high power LEDs, which are mounted on a substrate and covered by a hemispherical silicone dome in a conventional package. The light output from the LED package is typically lambertian, which means that the LED package emits light in all directions. In most cases, Total Internal Reflection (TIR) secondary optical elements are used to extract the light emitted from a conventional LED package and focus that light into a desired beam. In order to extract the maximum amount of light, the TIR optics must have a specific shape relative to the dome of the LED package. Other dimensions of the TIR optics determine the shape of the emitted light beam.

Some multi-color linear LED light products comprise individually packaged LEDs and individual TIR optics for each LED. In order for the light emitted from the different colored LED emitters to mix properly, the light beams from each individual color LED must overlap. However, because the LEDs are spaced centimeters apart, the beams will overlap and the colors will mix only in the far field, at some

distance away from the linear light. At a very close range to the linear light, the beams will be separate and the different colors are clearly visible. Although such a product may exhibit good color mixing in the far field, it does not exhibit good color mixing in the near field.

Other multi-color linear LED light products use red, green, and blue LEDs packaged together with a single TIR optic attached to each RGB LED package. These RGB LED packages typically comprise an array of three or four LEDs, which are placed as close together as possible on a substrate and the entire array is covered by one hemispherical dome. In products that use one TIR optical element for each multi-color LED package, there is not necessarily a need for the beams from the different TIR optical elements to overlap for the colors to mix. Therefore, such products tend to have better near field color mixing than products that use individually packaged LEDs.

However, depending on the size of the primary and secondary optics, the far field color mixing may actually be worse in products that package multiple colors of LEDs together. Since the different colored LEDs are in physically different locations within the hemispherical silicone dome, the light radiated from the dome, and therefore, from the TIR optical element will not be perfectly mixed. Although larger domes and larger TIR optical elements may be used to provide better color mixing, there are practical limits to the size of these components, and consequently, to the near and far field color mixing provided by such an approach.

An alternative optical system, although not commonly used, for color mixing and beam shaping in multi-color LED linear lights uses reflectors. In some cases, the light from a plurality of multi-colored LED emitter packages are mixed by a diffusion element and shaped by a concave reflector that redirects the light beams down a wall. The diffusion element could be combined with an exit lens or could be a shell diffuser placed over the multi-color emitter packages, for instance. Alternatively, the system could use a shell diffuser and a diffused exit lens. Although such systems can achieve very good color mixing in both the near and the far field, there is a tradeoff between color mixing and optical efficiency. As the amount of diffusion increases, the color mixing improves, but the optical efficiency decreases as the diffuser absorbs and scatters more light.

As LEDs age, the light output at a given drive current changes. Over thousands of hours, the light output from any individual LED may decrease by approximately 10-25% or more. The amount of degradation varies with drive current, temperature, color, and random defect density. As such, the different colored LEDs in a multi-color LED light will age differently, which changes the color of the light produced by the illumination device over time. A high quality multi-color LED light that can maintain precise color points over time should have the means to measure the light output from each color component, and adjust the drive current to compensate for changes. Further, a multi-color linear light should have the means to measure the light produced by each set of colored LEDs independent from other sets to prevent part of the linear light from producing a different color than other parts.

Multi-color LED linear lights with TIR optics on each individual LED cannot achieve good color mixing in the near field. Multi-color LED linear lights that combine a multi-color LED package with a TIR optical element require a large TIR optical element to achieve good color mixing in the near and far fields. Multi-color LED linear lights that use conventional diffusers and reflectors to achieve good color mixing in both the near and the far field suffer optical losses.

As such, there is a need for an improved optical system for multi-color LED linear lights that provides good color mixing in the near and far fields, is not excessively large and expensive, and has good optical efficiency. Further, there is a need for an optical feedback system to maintain precise color in such linear lights. The invention described herein provides a solution.

#### SUMMARY OF THE INVENTION

A linear multi-color LED illumination device that produces a light beam with uniform color throughout the output beam without the use of excessively large optics or optical losses is disclosed herein. In addition to improved color mixing, the illumination device includes a light detector and optical feedback for maintaining precise and uniform color over time and/or with changes in temperature. The illumination device described herein may also be referred to as a light, luminaire or lamp.

Various embodiments are disclosed herein for improving color mixing in a linear multi-color LED illumination device. These embodiments include, but are not limited to, a uniquely configured dome encapsulating a plurality of emission LEDs and a light detector within an emitter module, a unique arrangement of the light detector relative to the emission LEDs within the dome, a unique arrangement of a plurality of such emitter modules in a linear light form factor, and reflectors that are specially designed to improve color mixing between the plurality of emitter modules. The embodiments disclosed herein may be utilized together or separately, and a variety of features and variations can be implemented, as desired, to achieve optimum color mixing results. In addition, related systems and methods can be utilized with the embodiments disclosed herein to provide additional advantages or features. Although the various embodiments disclosed herein are described as being implemented in a linear light form factor, certain features of the disclosed embodiments may be utilized in illumination devices having other form factors to improve the color mixing in those devices.

According to one embodiment, an illumination device is disclosed herein as including a plurality of LED emitter modules, which are spaced apart from each other and arranged in a line. Each emitter module may include a plurality of emission LEDs whose output beams combine to provide a wide color gamut and a wide range of precise white color temperatures along the black body curve. For example, each emitter module may include four different colors of emission LEDs, such as red, green, blue, and white LEDs. In such an example, the red, green, and blue emission LEDs may provide saturated colors, while a combination of light from the RGB LEDs and a phosphor converted white LED provide a range of whites and pastel colors. However, the emitter modules described herein are not limited to any particular number and/or color of emission LEDs, and may generally include a plurality of emission LEDs, which include at least two different colors of LEDs. The plurality of LEDs may be arranged in a two-dimensional array (e.g., a square array), mounted on a substrate (e.g., a ceramic substrate), and encapsulated within a dome.

In some embodiments, the linear illumination device may comprise six emitter modules per foot, and each emitter module may be rotated approximately 120 degrees relative to the next adjacent emitter module. The rotation of subsequent emitters in the line improves color mixing between adjacent emitter modules to some degree. Although such an arrangement has been shown to provide sufficient lumen

output, efficacy, and color mixing, one skilled in the art would understand how the inventive concepts described herein can be applied to other combinations of LED numbers/colors per emitter module, alternative numbers of LED emitter modules per foot, and other angular rotations between emitter modules without departing from the scope of the invention.

In general, an illumination device in accordance with the present invention may include at least a first emitter module, a second emitter module, and a third emitter module arranged in a line, wherein the second emitter module is spaced equally distant between the first and third emitter modules. To improve color mixing, the second emitter module may be rotated X degrees relative to the first emitter module, and the third emitter module may be rotated 2X degrees relative to the first emitter module. X may be substantially any rotational angle equal to 360 degrees divided by an integer N, where N is greater than or equal to 3.

In some embodiments, color mixing may be further improved by covering each emitter module with an optically transmissive dome, whose shallow or flattened shape allows a significant amount of light emitted by the LED array to escape out of the side of the emitter module. For example, a shallow dome may be formed with a radius in a plane of the LED array that is about 20-30% larger than the radius of the curvature of the shallow dome. Such a shape may enable approximately 40% of the light emitted by the LED array to exit the shallow dome at small angles (e.g., approximately 0 to 30 degrees) relative to the plane of the LED array.

In some embodiments, color mixing may be further improved by the inclusion of a specially designed reflector, which is suspended above the plurality of emitter modules. The reflector comprises a plurality of louvers, each of which may be centered upon and suspended a spaced distance above a different one of the emitter modules. These louvers comprise a substantially circular shape with sloping sidewalls, which are angled so that a top diameter of the louver is substantially larger than a bottom diameter of the louver. The louvers are configured to focus a majority of the light emitted by the emitter modules into an output beam by configuring the bottom diameter of the louvers to be substantially larger than the diameter of the emitter modules. In some cases, the sloping sidewalls of the louvers may include a plurality of planar facets, which randomize the direction of light rays reflected from the planar facets.

By suspending the louvers a spaced distance above the emitter modules, the louvers allow the portion of the light that emanates sideways from adjacent emitter modules to mix underneath the louvers before that light is redirected out of the illumination device through an exit lens. In some embodiments, the louvers may be suspended approximately 5 mm to approximately 10 mm above the emitter modules. Other distances may be appropriate depending on the particular design of the emitter modules and the louvers.

In some embodiments, an exit lens may be provided with a combination of differently textured surfaces and/or patterns on opposing sides of the lens to further promote color mixing. For example, an internal surface of the exit lens may comprise a flat roughened surface that diffuses the light passing through the exit lens. An external surface of the exit lens may comprise an array of micro-lenses, or lenslets, to further scatter the light rays and shape the output beam.

In some embodiments, each emitter module may also comprise a detector, which is configured to detect light emitted by the emission LEDs. The detector is mounted onto the substrate and encapsulated within the shallow dome,

along with the emission LEDs, and may be an orange, red or yellow LED, in one embodiment. Regardless of color, the detector LED is preferably placed so as to receive the greatest amount of reflected light from the emission LED having the shortest wavelength. For example, the emission LEDs may include red, green, blue and white LEDs arranged in a square array, in one embodiment. In this embodiment, the detector LED is least sensitive to the shortest wavelength emitter LED, i.e., the blue LED. For this reason, the detector LED is positioned on the side of the array that is furthest from the blue LED, so as to receive the greatest amount of light reflected off the dome from the blue LED. In some cases, the dome may have a diffuse or textured surface, which increases the amount of light that is reflected off the surface of the dome back towards the detector LED.

In addition to the emitter modules, the illumination device described herein includes a plurality of driver circuits coupled to the plurality of LEDs for supplying drive currents thereto. During a compensation period, the plurality of driver circuits are configured to supply drive currents to the plurality of emission LEDs, one LED at a time, so that the detector LED can detect the light emitted by each individual LED. A receiver is coupled to the detector LED for monitoring the light emitted by each individual LED and detected by the detector LED during the compensation period. In some embodiments, the receiver may comprise a transimpedance amplifier that detects the amount of light produced by each individual LED. Control logic is coupled to the receiver and the driver circuits for controlling the drive currents produced by the driver circuits based on the amount of light detected from each LED. In some embodiments, the control logic may use optical and/or temperature measurements obtained from the emission LEDs to adjust the color and/or intensity of the light produced by the illumination device over time and/or with changes in temperature.

Various other patents and patent applications assigned to the assignee, including U.S. Publication No. 2010/0327764, describe means for periodically turning all but one emission LED off during the compensation period, so that the light produced by each emission LED can be individually measured. Other patent applications assigned to the assignee, including U.S. patent application Ser. Nos. 13/970,944; 13/970,964; and 13/970,990 describe means for measuring a temperature of the LEDs and adjusting the intensity of light emitted by the LEDs to compensate for changes in temperature. These commonly assigned patents and patent applications are incorporated by reference in their entirety. The invention described herein utilizes the assignee's earlier work and improves upon the optical measurements by placing the detector LED within the dome, and away from the shortest wavelength LED, to ensure the light for all emission LEDs is properly detected.

Any detector in a multi-color light source with optical feedback should be placed to minimize interference from external light sources. This invention places the detectors within the silicone dome to prevent interference from external sources and other emitter modules within the linear light. The detectors are preferably red, orange or yellow LEDs, but could comprise silicon diodes or any other type of light detector. However, red, orange or yellow detector LEDs are preferable over silicon diodes, since silicon diodes are sensitive to infrared as well as visible light, while LEDs are sensitive to only visible light.

In some embodiments, the illumination device may further include an emitter housing, a power supply housing coupled to the emitter housing and at least one mounting

bracket for mounting the illumination device to a surface (e.g., a wall or ceiling) The emitter modules, the reflector and the driver circuits described above reside within the emitter housing. The exit lens is mounted above the reflector and attached to sidewalls of the emitter housing. In some embodiments, the power supply housing may be coupled to a bottom surface of the emitter housing and comprises an orifice through which a power cable may be routed and connected to a power converter housed within the power supply housing. In some embodiments, a special hinge mechanism may be coupled between the emitter housing and the at least one mounting bracket. As described in the commonly assigned co-pending U.S. application Ser. No. 14/097,335, the hinge mechanism allows the emitter housing to rotate approximately 180 degrees relative to the mounting bracket around a rotational axis of the hinge mechanism. The co-pending application is hereby incorporated in its entirety.

#### DESCRIPTION OF THE DRAWINGS

Other objects and advantages of the invention will become apparent upon reading the following detailed description and upon reference to the accompanying drawings.

FIG. 1 is a picture of an exemplary full color gamut linear LED light.

FIG. 2 is an exemplary illustration of the rotating hinges shown in FIG. 1.

FIG. 3 provides additional illustration of the rotating hinge components.

FIG. 4 is a picture of exemplary components that may be included within the full color gamut linear LED light of FIG. 1.

FIG. 5 is an exemplary block diagram of circuitry that may be included on the driver board and the emitter board of the exemplary full color gamut linear LED light of FIG. 1.

FIG. 6 is an exemplary block diagram of the interface circuitry and emitter module of FIG. 5.

FIG. 7 is an illustration of an exemplary color gamut that may be produced by the linear LED light on a CIE1931 color chart.

FIG. 8 is a photograph of an exemplary LED emitter module comprising a plurality of emission LEDs and a detector LED mounted on a substrate and encapsulated in a shallow dome.

FIG. 9 is a side view drawing of the LED emitter module of FIG. 8.

FIG. 10A is a drawing of an exemplary LED emitter module depicting a desirable placement of the emission LEDs and the detector LED within the dome, according to one embodiment.

FIG. 10B is a drawing of an exemplary LED emitter module depicting another desirable placement of the emission LEDs and the detector LED within the dome, according to another embodiment.

FIG. 11 is a photograph of an exemplary emitter board comprising a plurality of LED emitter modules, wherein sets of the modules are rotated relative to each other to promote color mixing.

FIG. 12 is a photograph of an exemplary emitter board, emitter housing and reflector for a full color gamut linear LED light with a 120 degree beam angle.

FIG. 13 is a photograph of an exemplary emitter board, emitter housing and a reflector for a full color gamut linear LED light with a 60 degree beam angle.

FIG. 14 is an exemplary ray diagram illustrating how the shallow dome of the emitter modules and the reflector of FIG. 13 enable light rays from adjacent emitter modules to mix together to promote color mixing.

FIG. 15 is an exemplary drawing providing a close up view of one of the emitter modules and floating louvers shown in FIG. 14.

FIG. 16 is an exemplary drawing of an exit lens comprising a plurality of lenslets formed on an external surface of the lens, according to one embodiment.

FIG. 17 is an exemplary ray diagram illustrating the effect that the exit lens shown in FIG. 16 has on the output beam when the plurality of lenslets formed on the external surface is combined with a textured internal surface.

While the invention is susceptible to various modifications and alternative forms, specific embodiments thereof are shown by way of example in the drawings and will herein be described in detail. It should be understood, however, that the drawings and detailed description thereto are not intended to limit the invention to the particular form disclosed, but on the contrary, the intention is to cover all modifications, equivalents and alternatives falling within the spirit and scope of the present invention as defined by the appended claims.

#### DETAILED DESCRIPTION OF THE INVENTION

Turning now to the drawings, FIG. 1 is a picture of a linear LED lamp 10, according to one embodiment of the invention. As described in more detail below, linear LED lamp 10 produces light over a wide color gamut, thoroughly mixes the color components within the output beam, and uses an optical feedback system to maintain precise color over LED lifetime, and in some cases, with changes in temperature. The linear LED lamp 10 shown in FIG. 1 is powered by the AC mains, but may be powered by alternative power sources without departing from the scope of the invention. The light beam produced by LED lamp 10 can be symmetric or asymmetric, and can have a variety of beam angles including, but not limited to, 120×120, 60×60, and 60×30. If an asymmetric beam is desired, the asymmetric beam typically has a wider beam angle across the length of the lamp.

In general, LED lamp 10 comprises emitter housing 11, power supply housing 12, and rotating hinges 13. As shown more clearly in FIG. 4, and discussed below, emitter housing 11 comprises a plurality of LED driver circuits, a plurality of LED emitter modules and a reflector, which is mounted a spaced distance above the emitter modules for focusing the light emitted by the emitter modules. The power supply housing 12 comprises an AC/DC converter powered by the AC mains, in one embodiment. Rotating hinges 13 allow both emitter housing 11 and power supply housing 12 to rotate 180 degrees relative to a pair of mounting brackets 14, which provides installation flexibility. Although a pair of mounting brackets 14 are shown in FIG. 1, alternative embodiments of the LED lamp may include a greater or lesser number of brackets, as desired.

In linear lighting fixtures, such as LED lamp 10, one major design requirement is to have the power cable enter and exit through the axis of rotation. This requirement allows adjacent lighting fixtures to be independently adjusted, while maintaining a constant distance between connection points of adjacent lighting fixtures. However, this requirement complicates the design of the rotational hinges used in linear lighting, as it prevents the hinges from

both rotating and passing power through the same central axis. LED lamp 10 solves this problem by moving the rotational components of the hinge off-axis, and joining the rotational components to the central axis with a swing arm to a rack and pinion gear assembly. An embodiment of such a solution is shown in FIGS. 2-3 and described below.

As shown in FIG. 2, each rotating hinge 13 may include a swing arm 15, an end cap 17 and a hinge element 16. The end cap 17 may be configured with a flat upper surface for attachment to the emitter housing 11 and a semi-circular inner surface comprising a plurality of teeth. One end of the swing arm 15 is securely mounted onto the mounting bracket 14 of the linear LED lamp 10. In some embodiments, the swing arm 15 can be secured to the mounting bracket 14 by way of screws 19, as shown in FIG. 3. However, alternative means of attachment may be used in other embodiments of the invention. An opposite end of the swing arm 15 is coupled near the flat upper surface of the end cap 17 and is centered about the rotational axis of the hinge mechanism. The opposite end of the swing arm comprises a cable exit gland 18, which is aligned with the orifice of the power supply housing for routing the power cable into the power supply housing at the rotational axis of the hinge mechanism.

As shown in FIGS. 2 and 3, swing arm 15 houses a hinge element 16 that provides an amount of resistance needed to secure the lamp 10 in substantially any rotational position within a 180 degree range of motion. The hinge element 16 extends outward from within the swing arm 15 and generally comprises a position holding gear, which is configured to interface with the toothed end cap 17 of the linear LED lamp 10. In some embodiments, the hinge element 16 may further comprise a constant torque element that provides a substantially consistent amount of torque to the position holding gear, regardless of whether the position holding gear is stationary or in motion. In other embodiments, the constant torque element may be replaced with a high static energy/low kinetic energy rotational element to enable easier rotational adjustment, while still providing the necessary resistance to hold the lamp 10 in the desired rotational position.

The rotating hinge 13 shown in FIGS. 2-3 enables electrical wiring (e.g., a power cable) to be routed through the rotational axis of the rotating hinge 13 and to enter/exit the hinge at the cable exit gland 18. In some embodiments, a strain relief member (e.g., a nylon bushing) may be provided at the cable exit gland 18 to reduce the amount of strain applied to the electrical wiring in response to rotational movement about the rotational axis.

Unlike conventional lighting devices, the present invention provides both power and rotation through the same axis by positioning the rotational components of the hinge 13 (i.e., the hinge element 16 and end cap 17) away from the rotational axis of the hinge mechanism. This is achieved, in one embodiment, by positioning the position holding gear of the hinge element 16 so that it travels around the semi-circular inner surface of the end cap 17 in an arc, whose radius is a fixed distance (d) away from the rotational axis of the hinge 13.

FIG. 4 is a photograph of various components that may be included within LED lamp 10, such as a power supply board 20, emitter housing 11, emitter board 21, 120×120 degree reflector 22, 60×60 degree reflector 23, and exit lens 24. Although two reflectors are shown in the photograph of FIG. 4, the assembled LED lamp 10 would include either the 120×120 degree reflector 22 or the 60×60 degree reflector 23, but not both. Power supply board 20 connects the LED lamp 10 to the AC mains (not shown) and resides in power

supply housing 12 (shown in FIG. 1). Power supply board 20 provides DC power and control to emitter board 21, which comprises the emitter modules and driver circuits. Emitter board 21 resides inside emitter housing 11 and is covered by either reflector 22 or reflector 23. The exit lens 24 is mounted above the reflector 22/23 and attached to the sidewalls of the emitter housing 11. As shown in FIG. 1, the exit lens 24 is configured such that the external surface of the lens is substantially flush with the top of the sidewalls of the emitter housing. As described in more detail below, exit lens 24 may comprise an array of small lenses (or lenslets) on the external surface of the exit lens to improve color mixing and beam shape.

FIGS. 1 and 4 illustrate one possible set of components for a linear LED lamp 10, in accordance with the present invention. Other embodiments of linear LED lights could have substantially different components and/or dimensions for different applications. For instance, if LED lamp 10 was used for outdoor wall washing, the mechanics, optics and dimensions could be significantly different than those shown in FIGS. 1 and 4. As such FIGS. 1 and 4 provide just one example of a linear LED lamp.

FIG. 5 is an exemplary block diagram for the circuitry included on power supply board 20 and emitter board 21. Power supply board 20 comprises AC/DC converter 30 and controller 31. AC/DC converter 30 converts AC mains power to a DC voltage of typically 15-20V, which is then used to power controller 31 and emitter board 21. Each such block may further regulate the DC voltage from AC/DC converter 30 to lower voltages as well. Controller 31 communicates with emitter board 21 through a digital control bus, in this example. Controller 31 could comprise a wireless, powerline, or any other type of communication interface to enable the color of LED lamp 10 to be adjusted. In the illustrated embodiment, emitter board 21 comprises six emitter modules 33 and six interface circuits 32. Interface circuits 32 communicate with controller 31 over the digital control bus and produce the drive currents supplied to the LEDs within the emitter modules 33.

FIG. 6 illustrates exemplary circuitry that may be included within interface circuitry 32 and emitter modules 33. Interface circuitry 32 comprises control logic 34, LED drivers 35, and receiver 36. Emitter module 33 comprises emission LEDs 37 and a detector 38. Control logic 34 may comprise a microcontroller or special logic, and communicates with controller 31 over the digital control bus. Control logic 34 also sets the drive current produced by LED drivers 35 to adjust the color and/or intensity of the light produced by emission LEDs 37, and manages receiver 36 to monitor the light produced by each individual LED 37 via detector 38. In some embodiments, control logic 34 may comprise memory for storing calibration information necessary for maintaining precise color, or alternatively, such information could be stored in controller 31.

According to one embodiment, LED drivers 35 may comprise step down DC to DC converters that provide substantially constant current to the emission LEDs 37. Emission LEDs 37, in this example, may comprise white, blue, green, and red LEDs, but could include substantially any other combination of colors. LED drivers 35 typically supply different currents (levels or duty cycles) to each emission LED 37 to produce the desired overall color output from LED lamp 10. In some embodiments, LED drivers 35 may measure the temperature of the emission LEDs 37 through mechanisms described, e.g., in pending U.S. patent application Ser. Nos. 13/970,944; 13/970,964; 13/970,990; and may periodically turn off all LEDs but one to perform

optical measurements during a compensation period. The optical and temperature measurements obtained from the emission LEDs 37 may then be used to adjust the color and/or intensity of the light produced by the linear LED lamp 10 over time and with changes in temperature.

FIG. 7 is an illustration of an exemplary color gamut produced with the red, green, blue, and white emission LEDs 37 included within linear LED lamp 10. Points 40, 41, 42, and 43 represent the color produced by the red, green, blue, and white LEDs 37 individually. The lines 44, 45, and 46 represent the boundaries of the colors that this example LED lamp 10 could produce. All colors within the triangle formed by 44, 45, and 46 can be produced by LED lamp 10.

FIG. 7 is just one example of a possible color gamut that can be produced with a particular combination of multi-colored LEDs. Alternative color gamuts can be produced with different LED color combinations. For instance, the green LED within LEDs 37 could be replaced with another phosphor converted LED to produce a higher lumen output over a smaller color gamut. Such phosphor converted LEDs could have a chromaticity in the range of (0.4, 0.5) which is commonly used in white plus red LED lamps. Additionally, cyan or yellow LEDs could be added to expand the color gamut. As such, FIG. 7 illustrates just one exemplary color gamut that could be produced with LED lamp 10.

Detector 38 may be any device, such as a silicon photodiode or an LED, that produces current indicative of incident light. In at least one embodiment, however, detector 38 is preferably an LED with a peak emission wavelength in the range of approximately 550 nm to 700 nm. A detector 38 with such a peak emission wavelength will not produce photocurrent in response to infrared light, which reduces interference from ambient light. In at least one preferred embodiment, detector 38 may comprise a small red, orange or yellow LED.

Referring back to FIG. 6, detector 38 is connected to a receiver 36. Receiver 36 may comprise a trans-impedance amplifier that converts photocurrent to a voltage that may be digitized by an ADC and used by control logic 34 to adjust the drive currents, which are supplied to the emission LEDs 37 by the LED drivers 35. In some embodiments, receiver 36 may further be used to measure the temperature of detector 38 through mechanisms described, e.g., in pending U.S. patent application Ser. Nos. 13/970,944, 13/970,964, 13/970,990. This temperature measurement may be used, in some embodiments, to adjust the color and/or intensity of the light produced by the linear LED lamp 10 over changes in temperature.

FIG. 5 and FIG. 6 are just examples of many possible block diagrams for power supply board 20, emitter board 21, interface circuitry 32, and emitter module 33. In other embodiments, interface circuitry 32 could be configured to drive more or less LEDs 37, or may have multiple receiver channels. In yet other embodiments, emitter board 21 could be powered by a DC voltage, and as such, would not need AC/DC converter 30. Emitter module 33 could have more or less LEDs 37 configured in more or less chains, or more or less LEDs per chain. As such, FIG. 5 and FIG. 6 are just examples.

FIGS. 8-9 depict an exemplary emitter module 33 that may be used to improve color mixing in the linear LED lamp 10. As shown in FIG. 8, emitter module 33 may include an array of four emission LEDs 37 and a detector 38, all of which are mounted on a common substrate 70 and encapsulated in a dome 71. In one embodiment, the substrate 70 may be a ceramic substrate formed from an aluminum nitride or an aluminum oxide material (or some other

reflective material) and may generally function to improve output efficiency by reflecting light back out of the emitter module **33**.

The dome **71** may comprise substantially any optically transmissive material, such as silicone or the like, and may be formed through an overmolding process, for example. In some embodiments, a surface of the dome **71** may be lightly textured to increase light scattering and promote color mixing, as well as to reflect a small amount (e.g., about 5%) of the emitted light back toward the detector **38** mounted on the substrate **70**. The size of the dome **71** (i.e., the diameter of the dome in the plane of the LEDs) is generally dependent on the size of the LED array. However, it is generally desired that the diameter of the dome be substantially larger (e.g., about 1.5 to 4 times larger) than the diameter of the LED array to prevent occurrences of total internal reflection. As described in more detail below, the size and shape (or curvature) of the dome **71** is specifically designed to enhance color mixing between the plurality of emitter modules **33**.

FIG. **9** depicts a side view of the emitter module **33** to illustrate a desired shape of the dome **71**, according to one embodiment of the invention. As noted above, conventional emitter modules typically include a dome with a hemispherical shape, in which the radius of the dome in the plane of the LED array is the same as the radius of the curvature of dome. As shown in FIG. **9**, dome **71** does not have the conventional hemispherical shape, and instead, is a much flatter or shallower dome. In general, the radius ( $r_{dome}$ ) of the shallow dome **71** in the plane of the LED array is approximately 20-30% larger than the radius ( $r_{curve}$ ) of the curvature of dome **71**.

In one example, the radius ( $r_{dome}$ ) of the shallow dome **71** in the plane of the LEDs may be approximately 4.8 mm and the radius ( $r_{curve}$ ) of the dome curvature may be approximately 3.75 mm. The ratio of the two radii (4.8/3.75) is 1.28, which has been shown to provide the best balance between color mixing and efficiency for at least one particular combination and size of LEDs. However, one skilled in the art would understand how alternative radii and ratios may be used to achieve the same or similar color mixing results.

By configuring the dome **71** with a substantially flatter shape, the dome **71** shown in FIGS. **8-9** allows a larger portion of the emitted light to emanate sideways from the emitter module **33**. Stated another way, a shallower dome **71** allows a significant portion of the emitted light to exit the dome at small angles ( $\alpha_{side}$ ) relative to the horizontal plane of the LED array. In one example, the shallower dome **71** may allow approximately 40% of the light emitted by the array of LEDs **37** to exit the shallow dome at approximately 0 to 30 degrees relative to the horizontal plane of the LED array. In comparison, a conventional hemispherical dome may allow only 25% (or less) of the emitted light to exit between 0 and 30 degrees. As described in more detail below with reference to FIGS. **14-15**, the shallow dome **71** shown in FIGS. **8-9** improves color mixing in the linear LED lamp **10** by allowing a significant portion (e.g., 40%) of the light emitted from the sides of adjacent emitter modules to intermix before that light is reflected back out of the lamp.

FIGS. **10A-10B** are exemplary drawings of the emitter module **33** shown in FIGS. **8-9** including emission LEDs **37** and detector **38** within shallow dome **71**. As shown in FIGS. **10A-10B**, the four differently colored (e.g., red, green, blue and white) emission LEDs **37** are arranged in a square array and are placed as close as possible together in the center of the dome **71**, so as to approximate a centrally located point source. As noted above, it is generally desired that the

diameter ( $d_{dome}$ ) of the dome **71** in the plane of the LEDs is substantially larger than the diameter ( $d_{array}$ ) of the LED array to prevent occurrences of total internal reflection. In one example, the diameter ( $d_{dome}$ ) of the dome **71** in the plane of the LEDs may be approximately 7.5 mm and the diameter ( $d_{array}$ ) of the LED array may be approximately 2.5 mm. Other dimensions may be appropriate in other embodiments of the invention.

FIGS. **10A-10B** also illustrate exemplary placements of the detector **38** relative to the array of emission LEDs **37** within the shallow dome **71**. As shown in the embodiment of FIG. **10A**, the detector **38** may be placed closest to, and in the middle of, the edge of the array that is furthest from the short wavelength emitters. In this example, the short wavelength emitters are the green and blue LEDs positioned at the top of the array, and the detector **38** is an orange LED, which is least sensitive to blue light. Although somewhat counterintuitive, it is desirable to place the detector **38** as far away as possible from the blue LED so as to gather the most light reflected off the surface of the shallow dome **71** from the blue LED. As noted above, a surface of the dome **71** may be lightly textured, in some embodiments, so as to increase the amount of emitted light that is reflected back to the detector **38**.

FIG. **10B** illustrates an alternative placement for the detector **38** within the shallow dome **71**. In some embodiments, the best place for the detector **38** to capture the most light from the blue LED may be on the other side of the array, and diagonally across from, the blue LED. In the embodiment shown in FIG. **10B**, the detector **38** is preferably placed somewhere between the dome **71** and a corner of the red LED. Since the green LED produces at least 10x the photocurrent as the blue LED on the orange detector, FIG. **10B** represents an ideal location for an orange detector **38** in relation to the particular RGBW array **37** described above. However, the detector **38** may be positioned as shown in FIG. **10A**, without sacrificing detection accuracy, if there is insufficient space between the dome **71** and the corner of the red LED, as shown in FIG. **10B**.

FIG. **11** illustrates an exemplary emitter board **21** comprising six emitter modules **100, 101, 102, 103, 104,** and **105** arranged in a line. Each of the emitter modules shown in FIG. **11** may be identical to the emitter module **33** shown in FIGS. **8-10** and described above. FIG. **11** illustrates a preferred method for altering the orientation of emitter modules, or sets of emitter modules, to further improve color mixing there between. In the embodiment of FIG. **11**, the orientation of emitter modules **102** and **105** (i.e., a first set of emitter modules) is the same, the orientation of emitter modules **101** and **104** (i.e., a second set of emitter modules) is the same, and the orientation of emitter modules **100** and **103** (i.e., a third set of emitter modules) is the same. However, the orientation of the second set of emitter modules **101** and **104** is rotated 120 degrees from that of the first set of emitter modules **102** and **105**. Likewise, the orientation of the third set of emitter modules **100** and **103** is rotated 120 degrees from that of the second set of emitter modules **101** and **104**, and 240 degrees from the first set of emitter modules **102** and **105**. This rotation in combination with the shallow curvature of dome **71** enables the various colors of light produced by the plurality of emitter modules **100, 101, 102, 103, 104,** and **105** to thoroughly mix.

FIG. **11** is just one example of an emitter board **21** that may be used to improve color mixing in a linear LED lamp **10**. Although the emitter board **21** is depicted in FIG. **11** with six emitter modules spaced approximately 2 inches apart, an emitter board **21** in accordance with the present invention

## 13

could have substantially any number of emitter modules spaced substantially any distance apart. In embodiment shown in FIG. 11, three sets of emitter modules are rotated 120 degrees from each other. In other embodiments, however, one or more of the emitter modules could be rotated by any amount provided that the emitter modules on the emitter board 21 make an integer number of rotations along the length of emitter board 21.

For example, each emitter module may be rotated an additional X degrees from a preceding emitter module in the line. Generally speaking, X is a rotational angle equal to 360 degrees divided by an integer N, where N is greater than or equal to 3. The number N is dependent on the number of emitter modules included on the emitter board. For instance, with six emitter modules, each module could be rotated 60 or 120 degrees from the preceding emitter module. With eight emitter modules, each module could be rotated an additional 45 or 90 degrees. For best color mixing, the rotational angle X should be equal to 360 degrees divided by three or four depending on how many emitter modules are included on the emitter board 21.

FIG. 12 is a photograph of the emitter board 21 and reflector 22 placed within the emitter housing 11 of the linear LED lamp 10. In particular, FIG. 12 illustrates an exemplary placement of the emitter modules 33 and reflector 22 within emitter housing 11 for 120×120 degree beam applications. As noted above with regard to FIG. 11, each set of emitter modules 33 (e.g., modules 102/105, 101/104 and 100/103 shown in FIG. 11) may be rotated 120 degrees relative to each other to improve color mixing. In the embodiment of FIG. 12, the reflector 22 comprises a highly reflective material (e.g., vacuum metalized aluminum) that covers the entire inside of the emitter housing 11 except for the emitter modules 33. The reflector 22 used in this embodiment improves the overall optical efficiency of the lamp 10 by reflecting light scattered off the exit lens. The rotation of the emitter modules 33, the shallow dome 71, and the shape of the exit lens 24 (discussed below) all contribute to produce thorough color mixing throughout the 120×120 beam in this example.

FIG. 13 is a photograph of the emitter board 21 and reflector 23 placed within the emitter housing 11. In particular, FIG. 13 illustrates an exemplary placement of the emitter modules 33 and reflector 23 within emitter housing 11 for 60×60 degree beam applications. As in FIG. 12, the sets of emitter modules 33 may be rotated 120 degrees relative to each other to improve color mixing. Like reflector 22, reflector 23 also comprises a highly reflective material (e.g., vacuum metalized aluminum) to improve optical efficiency, however, reflector 23 additionally includes a plurality of louvers, each of which is centered around and suspended above a different one of the emitter modules 33. As depicted more clearly in FIGS. 14-15, the louvers are attached to the reflector 23 only on the sides and ends, and are open below. The space between the emitter modules 33 and the bottom of the louvers allows light emitted sideways from the emitter modules 33 to intermix to improve color uniformity in the output beam.

FIG. 14 is an exemplary ray diagram illustrating the color mixing effect between emitter modules 100-105 and reflector 23. As shown in FIG. 14, louvers 110, 111, 112, 113, 114, and 115 are individually centered upon and positioned above a majority of the light emitted from the emitter modules 100-105 into an output beam, but allow some of the light that emanates from the side of the emitter modules 100-105 to mix with light from other emitter modules. For example,

## 14

louver 112 focuses most of the light emitted from emitter module 102 into the output beam, however, some rays from emitter module 102 are reflected by louvers 111, 113, and 115. Likewise, louver 113 focuses most of the light emitted from emitter module 103; however, some rays from emitter module 103 are reflected by louvers 110, 112, and 114. The exemplary ray diagram of FIG. 14 illustrates only a limited number of rays. In reality, each louver 110-115 reflects some light from all emitter modules 100-105, which significantly improves color mixing in the resulting beam.

FIG. 15 illustrates a cross section of a portion of the exemplary 60×60 degree reflector 23 comprising louver 110 and emitter module 100. Louver 110 is attached to both lateral sides of reflector 23. The same is true for louvers 111-115. Additionally, louvers 110 and 115 are attached to the ends of reflector 23. In some embodiments, the louvers 110-115 may be attached to the sidewalls and ends of the reflector 23 by forming the louvers and reflector as one integral piece (e.g., by a molding process). Other means for attachment may be used in other embodiments of the invention.

The overall shape and size of the louvers 110-115 determine the shape, and to some extent the color, of the output beam. As shown in FIGS. 13-15, each louver has a substantially round or circular shape with sloping sidewalls. As shown in FIG. 15, the sidewalls of the louvers are angled outward, such that the diameter at the bottom of the louver ( $d_{bottom}$ ) is substantially smaller than the diameter at the top of the louver ( $d_{top}$ ). It is generally desired that the louvers 110-115 be substantially larger than the emitter modules 100-105, so that the louvers may focus a majority of the light emitted by the emitter modules into an output beam. As noted above, the diameter of the emitter module ( $d_{emit}$ ) may be about 7.5 mm, in one embodiment. In such an embodiment, the bottom diameter ( $d_{bottom}$ ) of the louver may be about 35 mm and the top diameter ( $d_{top}$ ) of the louver may be about 42 mm. Other dimensions and shapes may be appropriate in other embodiments of the invention. In one alternative embodiment, for example, the louvers may alternatively be configured with a substantially parabolic shape, as would be appropriate in 30×60 beam applications.

As further depicted in FIG. 15, the angle ( $\alpha_{ref}$ ) of the sidewalls of reflector 23 is substantially the same as the angle ( $\alpha_{ref}$ ) of the sidewalls of the louvers 110-115. According to one embodiment, the angle of the sidewall surfaces of the reflector 23 and the angle of the louvers 110-115 may be approximately 60 degrees. In the illustrated embodiment, the shape and size of the reflector and louvers are chosen for 60×60 beam applications. One skilled in the art would understand how alternative shapes and sizes may be used to produce other beam shapes. As such, FIGS. 13-15 are just example illustrations of the invention.

As further shown in FIG. 15, the louvers (e.g., 110) are formed so as to include a plurality of planar facets, or lunes 116, in the sidewalls. Lunes 116 are flattened segments in the otherwise round louvers 110-115. The lunes 116 generally function to randomize the direction of the light rays and improve color mixing. FIG. 15 further depicts how the louvers (e.g., 110) are suspended some height (h) above the emitter modules (e.g., 100). The height (h) is generally dependent on the shape of the shallow dome 71 and the configuration of the lunes 116. According to one embodiment, the louvers 110-115 may be suspended approximately 5 mm to approximately 10 mm above the emitter modules 100-105 to allow a sufficient amount of light to mix underneath the louvers.

15

In addition the features described above (e.g., the flattened dome shape, the rotated emitter modules, the reflector with floating louvers, etc.), the exit lens **24** of the linear LED lamp **10** provides an additional measure of color mixing and beam shaping for the output beam. In general, the exit lens **24** is preferably configured with some combination of differently textured surfaces and/or patterns on opposing sides of the exit lens. The exit lens **24** preferably comprises injection modeled PMMA (acrylic), but could comprise substantially any other optically transparent material.

FIGS. **16** and **17** illustrate one exemplary embodiment of an exit lens **24** comprising an internal surface having a flat roughened surface that diffuses the light passing through the exit lens, and an array of micro-lenses or lenslets **120** formed on an external surface of the lens. As shown in FIG. **16**, the lenslets **120** may be rectangular or square-shaped domes, and may be approximately 1 mm square, but could have a variety of other shapes and sizes. The curvature of lenslets **120** is defined by the radius of the arcs that create the lenslets. In one embodiment, the radius of the lenslets **120** is about 1 mm. Although any combination of size, shape and curvature of lenslets **120** is possible, such dimensions have been shown to provide optimum color mixing and beam shaping performance.

FIG. **16** is just one example of an exit lens **24**. One skilled in the art would understand how an exit lens may be alternatively configured to produce the same or similar color mixing results. In other embodiments, for example, the pattern on the exterior surface of the exit lens could be hexagonal instead of rectangular, and/or the diameter of the lenslets **120** could be different. Likewise, the curvature of the lenslets **120** could change significantly and still achieve the desired results. In general, the exit lens **24** described herein may provide improved color mixing with substantially any shape, any diameter, and any lenslet curvature by providing an array of lenslets on at least one side of the exit lens **24**. In some embodiments, an array of similarly or differently configured lenslets may also be provided on the interior surface of the exit lens.

FIG. **17** illustrates a ray diagram for the exemplary exit lens **24** shown in FIG. **16**. In this example, the light rays **130** from the emitter modules **33** enter the exit lens **24** through the flat roughened internal side and are diffused within the exit lens **24**. The scattered light rays within the exit lens **24** are further randomized by the array of lenslets **120** formed on the external side of the exit lens to produce an output beam **131** with substantially uniform color throughout the beam.

It will be appreciated to those skilled in the art having the benefit of this disclosure that this invention is believed to provide color mixing optics and optical feedback to produce uniform color throughout the output light beam of a multi-color linear LED illumination device. More specifically, the invention provides an emitter module comprising a plurality of emission LEDs and a detector LED, all of which are mounted on a substrate and encapsulated in a shallow dome. The shallow dome allows a significant portion of the emitted light to emanate from the side of the emitter module, where it can mix with light from other emitter modules to improve color mixing. The invention further improves color mixing within a multi-color linear LED illumination device by rotating sets of the emitter modules relative to each other and providing a reflector comprising a plurality of floating louvers, which are centered upon and suspended above each of the emitter modules. The floating louvers allow a portion of the light emitted from each emitter module to mix with light from other emitter modules to produce uniform color

16

throughout the resulting output beam. Further modifications and alternative embodiments of various aspects of the invention will be apparent to those skilled in the art in view of this description. It is intended that the following claims be interpreted to embrace all such modifications and changes and, accordingly, the specification and drawings are to be regarded in an illustrative rather than a restrictive sense.

What is claimed is:

**1.** An illumination device, comprising:

a plurality of emitter modules spaced apart from each other and arranged in a line, wherein each emitter module comprises an array of at least two different colors of light emitting diodes (LEDs), which are mounted on a substrate and encapsulated within a shallow dome, and wherein a flattened shape of the shallow dome allows a greater portion of light emitted by the array of LEDs to emanate sideways from the emitter module than a hemispherical shaped dome; and a reflector comprising a plurality of louvers, wherein each louver is centered upon and suspended a spaced distance above a different one of the emitter modules to focus a majority of light emitted by that emitter module into an output beam, and wherein each louver is configured to reflect the portion of the light that emanates sideways from adjacent emitter modules to improve color mixing in the output beam.

**2.** The illumination device as recited in claim **1**, wherein a radius of the shallow dome in a plane of the array of LEDs is 20-30% larger than a radius of a curvature of the shallow dome, so that the portion of the light that emanates sideways from the emitter module exits the shallow dome at small angles relative to a plane of the LED array.

**3.** The illumination device as recited in claim **2**, wherein approximately 40% of the light emitted by the array of LEDs exits the shallow dome at approximately 0 to 30 degrees relative to the plane of the LED array.

**4.** The illumination device as recited in claim **1**, wherein a top diameter of each louver is substantially larger than a bottom diameter of the louver.

**5.** The illumination device as recited in claim **4**, wherein the plurality of louvers each comprise a substantially circular shape with sloping sidewalls.

**6.** The illumination device as recited in claim **4**, wherein the plurality of louvers each comprise sidewalls with a substantially parabolic shape.

**7.** The illumination device as recited in claim **4**, wherein the louvers are configured to focus the majority of the light emitted by the emitter modules into the output beam by configuring the bottom diameter of the louvers to be substantially larger than a diameter of the emitter modules.

**8.** The illumination device as recited in claim **4**, wherein the sloping sidewalls of the louvers include a plurality of planar facets, which are configured to randomize a direction of light reflected from the planar facets.

**9.** The illumination device as recited in claim **4**, wherein the louvers are suspended approximately 5 mm to approximately 10 mm above the emitter modules to allow the portion of the light that emanates sideways from the emitter modules to mix underneath the louvers.

**10.** The illumination device as recited in claim **1**, wherein the plurality of emitter modules comprise at least a first emitter module, a second emitter module, and a third emitter module, and wherein:

the second emitter module is spaced equally distant between the first and third emitter modules;

the second emitter module is rotated X degrees relative to the first emitter module;

17

the third emitter module is rotated 2X degrees relative to the first emitter module; and  
 wherein X is a rotational angle equal to 360 degrees divided by an integer N, where N is greater than or equal to 3.

11. The illumination device as recited in claim 1, wherein the array of LEDs comprises at least four LEDs, which are mounted on the substrate close together and arranged in a square pattern near a center of the shallow dome.

12. The illumination device as recited in claim 11, wherein the array of LEDs comprises a red LED, a green LED, a blue LED and a white LED.

13. The illumination device as recited in claim 1, further comprising:

- an emitter housing, wherein the plurality of emitter modules and the reflector reside within the emitter housing; and
- an exit lens mounted above the reflector and attached to sidewalls of the emitter housing.

14. The illumination device as recited in claim 13, wherein an internal surface of the exit lens comprises a flat roughened surface that scatters light rays passing through the exit lens, and wherein an external surface of the exit lens comprises an array of lenslets that randomizes the scattered light rays.

15. *An illumination device, comprising:*  
*an emitter module comprising:*  
*at least two light emitting diodes (LEDs) mounted on a substrate; and*  
*a dome that encapsulates the at least two LEDs;*  
*wherein a radius of the dome in a plane of the LEDs is greater than a radius of curvature of the dome; and*  
*a reflector comprising a louver that is suspended a distance above the emitter module.*

16. The illumination device of claim 15, further comprising a plurality of emitter modules including the emitter module, wherein the plurality of emitter modules are spaced apart from each other and arranged in a line.

17. The illumination device of claim 15, wherein the at least two LEDs comprise a two by two array of LEDs.

18. The illumination device of claim 15, wherein the distance of the louver above the emitter module is within a range of approximately 5 mm to approximately 10 mm.

19. The illumination device of claim 18, wherein the louver comprises sloped sidewalls, and wherein the sloped sidewalls include a plurality of planar facets.

20. The illumination device of claim 15, wherein the radius of the dome in the plane of the LEDs is greater than the radius of curvature of the dome by 20-30%.

21. The illumination device of claim 20, wherein approximately 40% of light emitted by the at least two LEDs exits the dome at approximately 0 to 30 degrees relative to the plane of the LEDs.

22. The illumination device of claim 16, wherein the plurality of emitter modules comprise at least a first emitter module, a second emitter module, and a third emitter module, and wherein:

18

- the second emitter module is between the first emitter module and third emitter module;*
- the second emitter module is rotated X degrees relative to the first emitter module;*
- the third emitter module is rotated 2X degrees relative to the first emitter module; and*
- X is a rotational angle.*

23. The illumination device of claim 15, wherein the louver comprises sloped sidewalls, and wherein the sloped sidewalls include a plurality of planar facets.

24. The illumination device of claim 15, wherein a top diameter of the louver is larger than a bottom diameter of the louver.

25. The illumination device of claim 24, wherein the louver comprises a substantially circular shape.

26. The illumination device of claim 24, wherein the louver comprises a substantially parabolic shape.

27. The illumination device of claim 24, wherein the bottom diameter of the louver is larger than a diameter of the emitter module.

28. The illumination device of claim 24, wherein the louver comprises sloped sidewalls, and wherein the sloped sidewalls include a plurality of planar facets.

29. The illumination device of claim 15, further comprising an exit lens mounted above the reflector, wherein an internal surface of the exit lens comprises a flat roughened surface that scatters light rays passing through the exit lens, and wherein an external surface of the exit lens comprises an array of lenslets that randomizes the scattered light rays.

30. The illumination device of claim 29, further comprising a plurality of emitter modules including the emitter module.

31. The illumination device of claim 30, wherein the plurality of emitter modules are spaced apart from each other and arranged in a line, wherein the plurality of emitter modules comprise at least a first emitter module, a second emitter module, and a third emitter module, and wherein:

- the second emitter module is between the first emitter module and third emitter module;*
- the second emitter module is rotated X degrees relative to the first emitter module;*
- the third emitter module is rotated 2X degrees relative to the first emitter module; and*
- X is a rotational angle.*

32. The illumination device of claim 31, wherein the distance of the louver above the emitter module is within a range of approximately 5 mm to approximately 10 mm.

33. The illumination device of claim 32, wherein the radius of the dome in the plane of the LEDs is greater than the radius of curvature of the dome by 20-30%.

34. The illumination device of claim 33, wherein a top diameter of the louver is larger than a bottom diameter of the louver.

35. The illumination device of claim 34, wherein the bottom diameter of the louver is larger than a diameter of the emitter module.

\* \* \* \* \*