

(No Model.)

E. C. FASOLDT.  
VALVE OPERATING MECHANISM FOR ENGINES.

No. 485,579.

Patented Nov. 1, 1892.

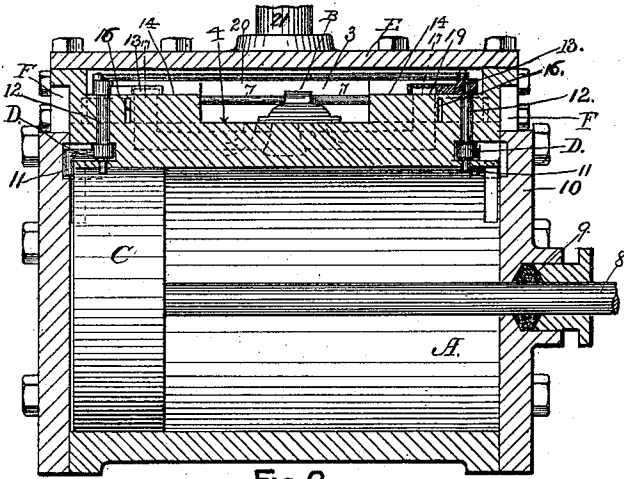

Fig. 2.

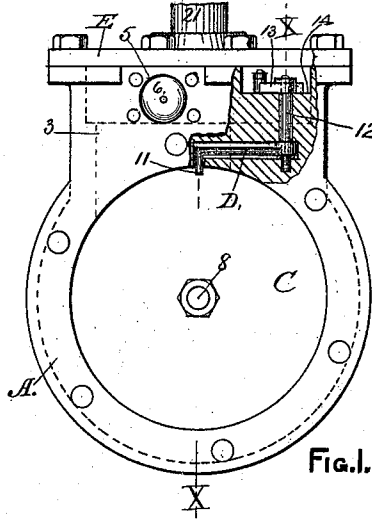

Fig. 1.

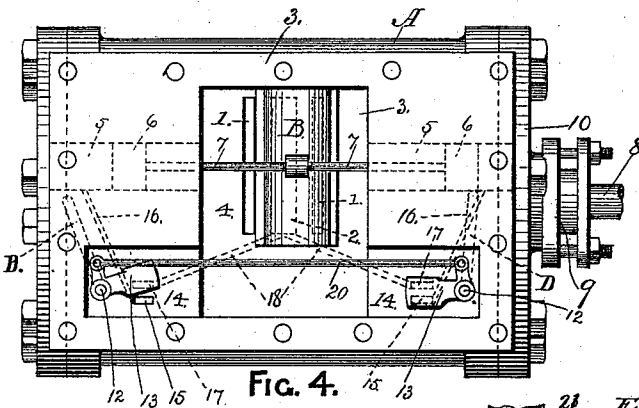

Fig. 4.

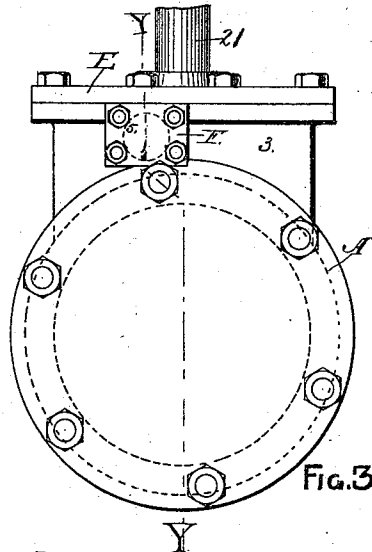

Fig. 3.

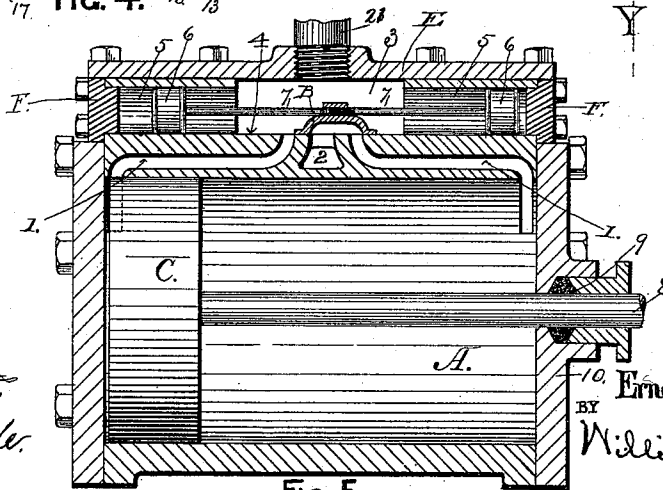

Fig. 5.

Witnesses:  
*S. B. Brown,*  
*J. E. Marble.*

Inventor:  
Ernest C. Fasoldt,  
BY  
*William H. Low,*  
Attorney.

# UNITED STATES PATENT OFFICE.

ERNEST C. FASOLDT, OF ALBANY, NEW YORK, ASSIGNOR OF ONE-HALF TO  
JOHN BOYD THACHER, OF SAME PLACE.

## VALVE-OPERATING MECHANISM FOR ENGINES.

SPECIFICATION forming part of Letters Patent No. 485,579, dated November 1, 1892.

Application filed July 20, 1892. Serial No. 440,651. (No model.)

*To all whom it may concern:*

Be it known that I, ERNEST C. FASOLDT, of the city and county of Albany, in the State of New York, have invented new and useful  
5 Improvements in Valve-Operating Mechanisms for Steam-Engines, of which the following is a specification.

My invention consists of the mechanism herein described, and shown in the accompanying drawings, for automatically operating  
10 the valves which control the admission and emission of steam into and out of the cylinders of steam-engines, steam-pumps, and other similar machinery.

15 In the accompanying drawings, which are herein referred to and form part of this specification, Figure 1 is an end elevation of a steam-cylinder from which the cylinder-head has been removed and parts broken away to  
20 expose certain parts that would be otherwise concealed. Fig. 2 is a longitudinal section of Fig. 1 at the irregular line X X. Fig. 3 is an end elevation of said steam-cylinder with the cylinder-head and bonnets fixed thereon.  
25 Fig. 4 is a plan view of said steam-cylinder with the steam-chest cover removed therefrom, and Fig. 5 is a longitudinal section of said steam-cylinder at the line Y Y on Fig. 3.

As represented in the drawings, A designates a steam-cylinder provided with my  
30 improvements and having the usual steam-passages 1 and exhaust-passage 2. On one side of said cylinder there is a steam-chest 3, which incloses a valve-seat 4, and two supplementary steam-cylinders 5, which are arranged  
35 opposite to each other in a longitudinal line. Each of said supplementary steam-cylinders is provided with an independent piston 6, which is fitted to reciprocate therein, and each  
40 of said pistons is provided with a piston-rod 7, having one end secured to the corresponding piston and the opposite end secured to a slide-valve B, which governs the admission of steam into the cylinder A and the exhaustion  
45 of the steam from said cylinder.

C designates a piston that is fitted to reciprocate in the bore of the cylinder A in the usual manner. Said piston is secured to a piston-rod 8, which passes through a stuffing-  
50 box 9, formed on a cylinder-head 10, in the old and well-known method of construction, and

said piston-rod may be connected to a cross-head of ordinary construction, or it may form a connection with the piston-rod of a water-cylinder, as in the ordinary construction of steam-  
55 pumps.

D designates a pair of crank-arms, of which one is fixed at opposite ends of the cylinder A, and each is provided with a pin 11, that is arranged perpendicularly to said arm and is  
60 fitted to extend into the path of the piston C, so that when the latter is near the completion of its movement in either direction it will take against the pin 11 at the corresponding  
65 end of the cylinder for the purpose of imparting a movement in a corresponding direction to the movement of said piston to the arm which is thus brought in contact with the piston. Each arm is secured to separate  
70 pivots 12, which are journaled at opposite ends of the cylinder A within the body of the latter, and to the outer end of each of said pivots a valve 13 is secured. Said valve is fitted to vibrate on a valve-seat 14, formed at  
75 opposite ends of the steam-chest 3. Leading from each of said valve-seats there is an induction-port 15, which communicates with the outer end of the bore of the corresponding  
80 auxiliary steam-cylinder 5 by means of a steam-passage 16. (Shown in Fig. 2 and indicated by dotted lines in Fig. 4.) Said valve-seats are each provided with an exhaust-port 17, (indicated by dotted lines in Figs. 2 and  
85 4.) which communicate with the exhaust-passage 2 of the main cylinder A by means of passages 18. (Indicated by dotted lines in Fig. 4.) Each valve 13 is provided with a chamber 19, that forms a communication between the induction-port 15 and exhaust-port  
90 17 when the valve is moved over to cover both of said ports. The two valves 13 are connected together by means of a rod 20, so that their movements, which are made simultaneously, will be in opposite directions.

E designates the steam-chest bonnet, which  
95 is fitted to cover over said steam-chest and its contained valves B and 13 and is provided with a steam-supply pipe 21, which conveys the steam from a suitable generator or into said steam-chest and thence into the cylinder  
100 A.

F designates bonnets or heads which form

closures for the outer end of the bore of the supplementary steam-cylinders 5.

My invention operates in the following manner: Assuming that the piston C has reached one extremity of its movement in the cylinder A, as shown in Fig. 2, so as to operate the arm D at the end of cylinder to which said piston has attained, whereby the valves 13 will be moved into the positions shown in the figure last referred to, thereby opening the induction-port 15 at that end of the cylinder A, to which the piston C has moved, thereby steam will be admitted into the supplementary steam-cylinder 5 at the corresponding end of the cylinder A to force the piston of said supplementary cylinder toward the middle of the main cylinder, and thereby the slide-valve B will be moved to uncover the steam-induction port for the steam-passage 1, with which said port communicates, by the admission of steam through said steam-passage. The piston C will be forced toward the opposite end of the cylinder A to take against the crank-arm D at that end of the cylinder, and thereby the valves 13 will be moved to permit the steam to enter the supplementary steam-cylinder at the end of the cylinder last referred to to effect a movement of the slide-valve B, that will cause the piston C to make a stroke in a direction reversed to the one it has previously made, and in this

manner the operation can be continued as long as the steam flows into the steam-chest E.

What I claim as my invention, and desire to secure by Letters Patent, is—

The combination, with a principal steam-cylinder provided with induction and eduction passages of the usual forms, supplementary steam-cylinders on the side of said principal cylinder and having their center lines arranged parallel to that of the principal cylinder, each of said supplementary cylinders being provided with a piston which is connected to a slide-valve which governs the admission of steam into the principal cylinder, and a piston fitted to move reciprocally in said principal cylinder, of a pair of crank-arms arranged at opposite ends of said principal cylinder and having their free ends lying in the path of the piston of said cylinder, said arms being secured to arbors fitted to oscillate in the body of said cylinder, said arbors being each provided with a vibratile valve which governs induction and eduction ports leading into and from said supplementary cylinders, as and for the purpose herein specified.

ERNEST C. FASOLDT.

Witnesses:

WM. H. LOW,  
S. B. BREWER.