

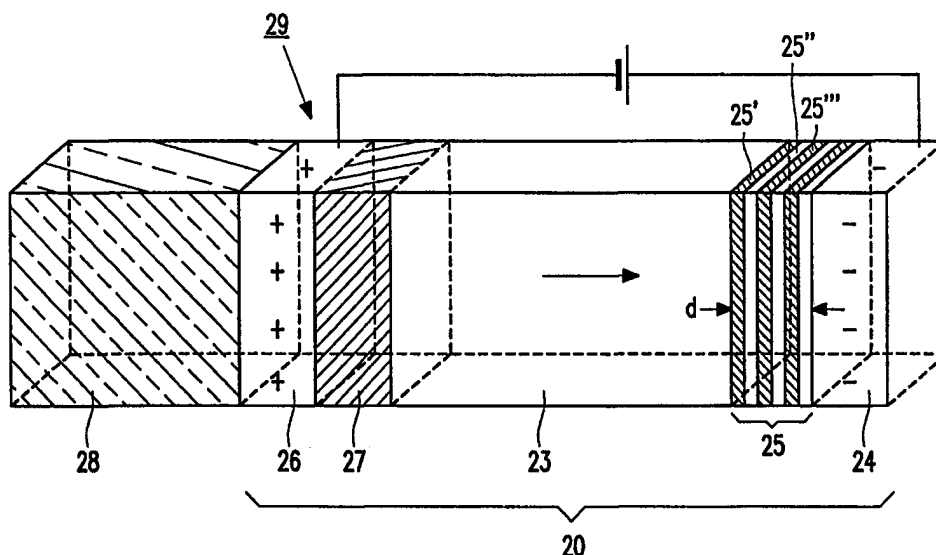

INTERNATIONAL APPLICATION PUBLISHED UNDER THE PATENT COOPERATION TREATY (PCT)

<p>(51) International Patent Classification ⁶ : G02F 1/153</p>	<p>A1</p>	<p>(11) International Publication Number: WO 98/48323</p> <p>(43) International Publication Date: 29 October 1998 (29.10.98)</p>
<p>(21) International Application Number: PCT/IB98/00329</p> <p>(22) International Filing Date: 12 March 1998 (12.03.98)</p> <p>(30) Priority Data: 97201146.4 18 April 1997 (18.04.97) EP (34) Countries for which the regional or international application was filed: NL et al.</p> <p>(71) Applicant: KONINKLIJKE PHILIPS ELECTRONICS N.V. [NL/NL]; Groenewoudseweg 1, NL-5621 BA Eindhoven (NL).</p> <p>(71) Applicant (for SE only): PHILIPS AB [SE/SE]; Kottbygatan 7, Kista, S-164 85 Stockholm (SE).</p> <p>(72) Inventors: VINK, Teunis, Johannes; Prof. Holstlaan 6, NL-5656 AA Eindhoven (NL). BOONEKAMP, Erik, Paul; Prof. Holstlaan 6, NL-5656 AA Eindhoven (NL). VERBEEK, Roy, Gerardus, Franciscus, Antonius; Prof. Holstlaan 6, NL-5656 AA Eindhoven (NL).</p> <p>(74) Agent: KOPPEN, Jan; Internationaal Octrooibureau B.V., P.O. Box 220, NL-5600 AE Eindhoven (NL).</p>		<p>(81) Designated States: JP, European patent (AT, BE, CH, DE, DK, ES, FI, FR, GB, GR, IE, IT, LU, MC, NL, PT, SE).</p> <p>Published <i>With international search report.</i></p>

(54) Title: ELECTROCHROMIC ELEMENT, A DISPLAY DEVICE PROVIDED WITH SAME AND A METHOD OF MANUFACTURING AN ELECTROCHROMIC LAYER



(57) Abstract

The electrochromic element (20) comprises a substrate (28) and an electrochromic layer (25) having a thickness d on the basis of a metal oxide selected from the group formed by tungsten oxide, molybdenum oxide, niobium oxide, manganese oxide and zirconium oxide, or combinations thereof. The electrochromic layer (25) is characterized in that the oxygen content in the layer (25) varies across the thickness d of the layer (25). Preferably, the variation of the oxygen content in the layer (25) comprises at least two local maxima and a local minimum. Preferably, the electrochromic layer (25) is composed of a plurality of sub-layers (25', 25'', 25'''), with the variation of the oxygen content in the layer (25) occurring predominantly at the location of transitions between two sub-layers. Preferably, the electrochromic layer (25) comprises the metal oxide tungsten oxide WO_x . The electrochromic element may be provided on the display screen of a display device. A description is given of a method of manufacturing the electrochromic layer (25).

FOR THE PURPOSES OF INFORMATION ONLY

Codes used to identify States party to the PCT on the front pages of pamphlets publishing international applications under the PCT.

AL	Albania	ES	Spain	LS	Lesotho	SI	Slovenia
AM	Armenia	FI	Finland	LT	Lithuania	SK	Slovakia
AT	Austria	FR	France	LU	Luxembourg	SN	Senegal
AU	Australia	GA	Gabon	LV	Latvia	SZ	Swaziland
AZ	Azerbaijan	GB	United Kingdom	MC	Monaco	TD	Chad
BA	Bosnia and Herzegovina	GE	Georgia	MD	Republic of Moldova	TG	Togo
BB	Barbados	GH	Ghana	MG	Madagascar	TJ	Tajikistan
BE	Belgium	GN	Guinea	MK	The former Yugoslav Republic of Macedonia	TM	Turkmenistan
BF	Burkina Faso	GR	Greece	ML	Mali	TR	Turkey
BG	Bulgaria	HU	Hungary	MN	Mongolia	TT	Trinidad and Tobago
BJ	Benin	IE	Ireland	MR	Mauritania	UA	Ukraine
BR	Brazil	IL	Israel	MW	Malawi	UG	Uganda
BY	Belarus	IS	Iceland	MX	Mexico	US	United States of America
CA	Canada	IT	Italy	NE	Niger	UZ	Uzbekistan
CF	Central African Republic	JP	Japan	NL	Netherlands	VN	Viet Nam
CG	Congo	KE	Kenya	NO	Norway	YU	Yugoslavia
CH	Switzerland	KG	Kyrgyzstan	NZ	New Zealand	ZW	Zimbabwe
CI	Côte d'Ivoire	KP	Democratic People's Republic of Korea	PL	Poland		
CM	Cameroon	KR	Republic of Korea	PT	Portugal		
CN	China	KZ	Kazakstan	RO	Romania		
CU	Cuba	LC	Saint Lucia	RU	Russian Federation		
CZ	Czech Republic	LI	Liechtenstein	SD	Sudan		
DE	Germany	LK	Sri Lanka	SE	Sweden		
DK	Denmark	LR	Liberia	SG	Singapore		
EE	Estonia						

Electrochromic element, a display device provided with same and a method of manufacturing an electrochromic layer.

The invention relates to an electrochromic element comprising a substrate and an electrochromic layer having a thickness d on the basis of a metal oxide selected from the group consisting of tungsten oxide, molybdenum oxide, niobium oxide, manganese oxide and zirconium oxide or combinations thereof, the transmission properties of the electrochromic layer in the visible range being governed by an applied voltage difference across the electrochromic layer.

The invention also relates to a display device provided with a display screen and an electrochromic element.

The invention further relates to a display device comprising a plurality of pixels including an electrochromic element.

The invention further relates to a method of manufacturing an electrochromic layer on the basis of a metal oxide selected from the group composed of tungsten oxide, molybdenum oxide, niobium oxide, manganese oxide and zirconium oxide or combinations thereof, the transmission properties of the electrochromic layer in the visible range being governed by an applied voltage difference across the electrochromic layer, said electrochromic layer being provided by means of a sputter-deposition process in an evacuated chamber.

Electrochromic elements for varying the transmission of light are used to influence the transmission and/or reflection of (visible) light, for example, of lamps, of rear view mirrors and of sunroofs for cars, or of windows for buildings (smart windows), or of lenses, or of spectacle lenses for (sun) glasses. They are also used on the viewing side of display windows of (flat-panel) display devices, such as cathode ray tubes (CRTs), plasma display panels (PDPs) and liquid-crystal display devices (LCDs, LC-TVs and plasma-addressed LCDs) to improve the contrast of the image reproduced. By virtue thereof, the feasibility of readily bringing the light transmission to a desired value is increased and, for example, the necessity of changing the glass composition of the display window of a display device is avoided.

The electrochromic elements mentioned in the opening paragraph influence the intensity of reflected ambient light and the intensity of light originating from an

(internal) light source, such as the phosphors in a CRT. Incident ambient light passes through the electrochromic element and is reflected at the substrate or at the phosphors of color filters in a CRT, whereafter the reflected light passes through the electrochromic element again. If the transmission of the electrochromic element amounts to T , the intensity of the reflected ambient light decreases by a factor of T^2 . Light originating from the internal light source(s), however, passes through the electrochromic element only once, so that the intensity of this light decreases only by a factor of T . The combination of these effects leads to an increase of the contrast by a factor of T^{-1} .

Oxides of specific transition metals are capable of accepting guest atoms such as hydrogen and alkali-metal atoms. If the oxide forms part of an electrochemical cell (the electrochromic element), the guest atoms can be accepted and released again in a reversible manner. In general, an electrochromic element comprises a first (transparent, conductive) electrode which is connected to an electrochromic layer, the so-called work electrode, and a second (transparent, conductive) electrode, the so-called counter electrode, which contains a material which serves as a source and as an acceptor for the guest atoms, and an ion-conducting (liquid, polymeric or solid) material, the so-called electrolyte, being present between said two electrodes. The transmission properties of the electrochromic element in the visible range undergo a change when a voltage difference is applied across the electrochromic element. As the variation in light is often detected via a light sensor provided in the vicinity of the electrochemical cell, this is referred to as an indirect response to a variation in light.

An electrochromic element of the type mentioned in the opening paragraph is disclosed in United States patent specification US 4,824,222. In said specification, a description is given of an electrochromic element which comprises an electrochromic layer containing molybdenum oxide (MoO_3), tungsten oxide (WO_3), zirconium oxide (ZrO_2) or niobium oxide (Nb_2O_5), or combinations thereof, as the electrochromic metal oxide.

Such electrochromic elements often have the disadvantage that their transmission spectrum is not color neutral when the voltage difference is applied across the electrochromic layer (the so-called "colored" state).

It is an object of the invention to provide, inter alia, an electrochromic element which comprises an electrochromic layer of the type mentioned in the opening paragraph, and the color neutrality of which is improved. The invention further aims at providing a simple method of manufacturing such an electrochromic layer.

5 To achieve this, the electrochromic element in accordance with the invention is characterized in that the oxygen content in the electrochromic layer varies across the thickness of said electrochromic layer.

As, in accordance with the measure of the invention, the oxygen content of the electrochromic layer varies across the thickness d of the layer (this is brought about by
10 varying the oxygen content in the course of the manufacture of the layer), a metal oxide which is not stoichiometric is obtained. For example, if a stoichiometric metal oxide has the structural formula MO_3 , a non-stoichiometric metal oxide MO_x has an average oxygen content below three, in other words, in the structural formula MO_x , x has a value < 3 . By varying the oxygen content of the electrochromic layer across the thickness d of the layer, a
15 change in the so-called band gap of the metal oxide is brought about, which leads to a change of the spectral transmission of the metal oxide. The surprising result of the measure in accordance with the invention is that, in the colored state (when the voltage difference is applied across the electrochromic element and the layer is intercalated), the metal oxide is not (dark-)colored (for example, in the colored state, electrochromic tungsten oxide exhibits a
20 characteristic (deep-)blue color) but is of a color-neutral grey color instead.

In the known electrochromic element, appropriate concentrations of suitable guest materials (for example oxides of (transition) metals such as V_2O_5 or TiO_2) are added to the metal oxide to reduce the undesirable coloration of the metal oxide in the colored state. Such additions have the disadvantage that the materials added are relatively
25 expensive, the incorporation of same in the metal oxide requires additional process steps and, in addition, that such additions to the metal oxide reduce the transmission of the electrochromic element in the uncolored state. Besides, in general, prolonged investigations are necessary to find out which concentration of which materials yields the desired effect.

An embodiment of the electrochromic element in accordance with the
30 invention is characterized in that the variation of the oxygen content in the electrochromic layer comprises at least two local maxima and a local minimum. A variation of the oxygen content in the electrochromic layer means that, if the structural formula of the metal oxide is indicated by MO_x , in which, for example, $x = 3$ corresponds to the stoichiometric form of the metal oxide, the value of x varies across the layer. The variation of x across the

electrochromic layer goes from a maximum, where the oxygen content is relatively high (for example $x \approx 3$ or $x \approx 2.5$) via a minimum, where the oxygen content is relatively low (for example $x \approx 2$ or $x \approx 1$) to a further maximum, where the oxygen content is high again.

The electrochromic layer comprises, as it were, a (local) region in which the oxygen content is lower than in the surrounding regions. Preferably, the variation of the oxygen content in the electrochromic layer comprises at least a plurality of local maxima alternated with an (at least substantially corresponding) number of local minima.

An embodiment of the electrochromic element in accordance with the invention is characterized in that the layer comprises a plurality of sub-layers in which the oxygen content varies from sub-layer to sub-layer. By (regularly) varying the oxygen content (during the manufacture of the layer), an electrochromic layer on the basis of the metal oxide is obtained, in which the oxygen content of the layer varies (regularly). The spectral properties of the layer can be influenced in a desirable manner by periodically varying the composition of the electrochromic layer across the thickness d of the layer. Preferably, the layer exhibits a reduced oxygen content, predominantly, at the location of the transitions between two sub-layers. In this manner, a stack of sub-layers is formed, which sub-layers themselves comprise, predominantly, at least substantially stoichiometric metal oxide (for example MO_3), while the metal oxide at (or in the vicinity of) the transitions between the sub-layers comprises non-stoichiometric metal oxide (MO_x , wherein $x < 3$). In this manner, the transitions between the layers form a region in which, locally, the oxygen content of the electrochromic layer is lower (for example as a result of an oxygen depletion during the manufacture of the layer). In this manner, a thicker layer of electrochromic metal oxide is reproducibly obtained, which layer exhibits the desired color-neutral properties in the colored state.

Preferably, the metal oxide comprises tungsten oxide. Upon the application of the voltage difference (referred to as "intercalating") across the electrochromic layer, the known electrochromic tungsten oxide (WO_3) undergoes a reversible change from (colorless) transparent in the so-called bleached state to dark-colored blue in the so-called colored state. The inventors have recognized that the measure in accordance with the invention ensures that, upon the application of a voltage difference, a reversible change from (colorless) transparent in the bleached state to color-neutral grey in the colored state occurs. As a result, the incorporation of other metal oxides (such as vanadium oxide and titanium oxide) in the electrochromic tungsten oxide to reduce the characteristic blue color of the tungsten oxide in the colored state has become superfluous.

An embodiment of the electrochromic element in accordance with the invention is characterized in that upon the application of the voltage difference, the electrochromic layer exhibits such a spectral characteristic that the difference between the maximum transmission T_{\max} and the minimum transmission T_{\min} of the electrochromic layer in the visible range is less than 35% of the sum of T_{\max} and T_{\min} , that is, in formulated form:

$$\frac{T_{\max} - T_{\min}}{T_{\max} + T_{\min}} \leq 0,35.$$

The degree to which the color neutrality of the metal oxide in the colored state is expressed is determined, in this application, by measuring the spectral characteristic of the metal oxide (tungsten oxide) when the voltage difference is applied. For this purpose, in particular, the variation of the transmission curve of the metal oxide in the visible range is experimentally measured. In general, the visible range comprises the following wavelength range: $400 \leq \lambda \leq 780$ nm, wherein λ is the wavelength of the light. In general, the measured transmission curve exhibits a maximum value T_{\max} and a minimum value T_{\min} in the visible range. In order to obtain a measure of the flatness of the transmission curve, which is relatively independent of the average transmission value in the visible range, the ratio ΔT_{rel} of the difference between the maximum and the minimum transmission to the sum of the maximum and the minimum transmission is determined, that is, in formulated form:

$$\Delta T_{\text{rel}} = \frac{T_{\max} - T_{\min}}{T_{\max} + T_{\min}}.$$

The known tungsten oxide, which, in the colored state, exhibits the characteristic blue color, said ratio ΔT_{rel} generally exceeds 0.4. For example, in the case of a measurement in the colored state of stoichiometric WO_3 , the following values are found: $T_{\max} \approx 0.3$ and $T_{\min} \approx 0.1$, so that $\Delta T_{\text{rel}} \approx 0.5$. In this case, the maximum value of the transmission (evidently) occurs on the "blue side" of the visible range ($\lambda \approx 400$ nm), while the transmission from said "side" decreases gradually in the direction of the "red side" of the visible range ($\lambda \approx 780$ nm), where the transmission is minimal. Such a variation in spectral characteristic of the known electrochromic element, used to reduce the reflection of visible light, causes the color rendition of an image passed by the electrochromic element to be disturbed. In particular, the color rendition of the skin of persons is adversely influenced thereby, resulting in an "unhealthy" appearance of these persons.

By contrast, an electrochromic element in accordance with the above

embodiment of the invention has a relatively good color-neutral appearance in the colored state as said ratio ΔT_{rel} is below 0.35. For example, if use is made of the non-stoichiometric WO_x in accordance with the invention, the following maximum and minimum transmission values are measured: $T_{max} \approx 0.2$ and $T_{min} \approx 0.1$. Consequently, $\Delta T_{rel} \approx 0.3$. In this case, 5 the maximum value of the transmission in the visible range occurs at a wavelength $\lambda \approx 500$ nm, while the transmission is minimal at approximately $\lambda \approx 750$ nm.

A further improvement of the color neutrality of the electrochromic element is obtained if the difference between the maximum transmission T_{max} and the minimum transmission T_{min} of the electrochromic layer in the visible range is less than 20% 10 of the sum of T_{max} and T_{min} , in other words, $\Delta T_{rel} \leq 0.2$. As a result, the transmission curve in the visible range, in the colored state, becomes at least substantially "flat". For example, if use is made of non-stoichiometric WO_x in accordance with the invention, the following maximum and minimum transmission values are measured: $T_{max} \approx 0.15$ and $T_{min} \approx 0.1$. Consequently, $\Delta T_{rel} \approx 0.14$. In this case, the maximum value of the transmission in the 15 visible range occurs at a wavelength $\lambda \approx 500$ nm, while the transmission is minimal at approximately $\lambda \approx 750$ nm. Such a variation in spectral characteristic of such an electrochromic element which is used to reduce the reflection of visible light of a display device leads to an excellent color rendition, for example, of the image displayed on the display window of the display device, and, in particular, also the color rendition of the skin 20 of persons being such that the desired "healthy" appearance is achieved in the image displayed.

A further embodiment of the electrochromic element in accordance with the invention is characterized in that the oxygen content of the WO_x ranges between $0 \leq x \leq 3$. The stoichiometry of the WO_x may vary over a wide range. A precondition 25 which must be met is that the electrochromic character of the layer is preserved. The variation in stoichiometry may signify that a part of the WO_x layer does not comprise oxygen ($x = 0$) and that another part of the WO_x layer comprises stoichiometric oxygen ($x = 3$). Preferably, the oxygen content of the WO_x ranges between $1 \leq x \leq 3$. Undesirable absorption of (visible) light by the electrochromic layer is precluded by avoiding parts in the 30 layer which do not, or hardly, contain oxygen ($x < 1$).

It is desirable that, depending on the applied voltage difference across the electrochromic layer in accordance with the invention, said electrochromic layer should have a color-neutral appearance at all stages between (colorless) transparent in the bleached state (transmission of the layer $\approx 90\%$) and (color-neutral) (dark-)grey in the (maximally) colored

state (transmission of the layer $\geq 10\%$).

The object of providing a simple method of manufacturing an electrochromic layer on the basis of a metal oxide selected from the group formed by tungsten oxide, molybdenum oxide, niobium oxide, manganese oxide and zirconium oxide, or combinations thereof, with said electrochromic layer being provided by means of a sputter-deposition process in an evacuated chamber, is achieved by a method as described in the opening paragraph, which method is characterized in that during the provision of the electrochromic layer, the oxygen content in the chamber is varied.

In general, such electrochromic layers are manufactured in a so-called sputter-deposition process. In a sputter-deposition process, a mixture of ions is used in an (evacuated) deposition chamber to bombard a so-called target from which atom-scale particles are released whose energy content is sufficient to reach the substrate. Oxidation of the layers is brought about by admitting the desirable quantity of oxygen to the deposition chamber during sputtering (reactive sputtering). The desirable non-stoichiometric properties of the metal oxide are obtained by varying the oxygen content during the provision of the layer in a controlled manner, the electrochromic layer manufactured in accordance with the invention exhibiting the desired spectral characteristic of the electrochromic layer.

Preferably, during the deposition process, the oxygen content is varied, in such a manner that the variation of the oxygen content in the electrochromic layer comprises at least two local maxima and a local minimum. Preferably, the electrochromic layer provided during the deposition process comprises tungsten oxide WO_x .

In an embodiment of the method in accordance with the invention, the oxygen content is varied, during the manufacture of the WO_x , in such a manner that the oxygen content of the layer varies between $0 \leq x \leq 3$. Preferably, the oxygen content of the layer ranges between $1 \leq x \leq 3$.

By (regularly) varying the oxygen content during the manufacture of the layer, an electrochromic layer on the basis of tungsten oxide is formed in which the oxygen content varies (regularly). In this manner, a stack of sub-layers is obtained which are partly stoichiometric and partly non-stoichiometric. Preferably, the oxygen content is varied in such a manner that the layer exhibits a reduced oxygen content predominantly at the location of the transitions from a sub-layer to a subsequent sub-layer. In this manner, a stack of sub-layers is obtained, which sub-layers themselves predominantly comprise at least substantially stoichiometric WO_3 , while the tungsten oxide at (or in the vicinity of) the transitions between the sub-layers comprises non-stoichiometric WO_x . By varying the oxygen content in the

evacuated chamber in a regular manner during the manufacture of the electrochromic layer, sufficient non-stoichiometric WO_x is obtained to preclude undesirable color effects during the transition from the bleached state to the colored state.

These and other aspects of the invention will be apparent from and
5 elucidated with reference to the embodiments described hereinafter.

In the drawings:

Fig. 1A is a partly cut-away view of a display device comprising a
10 cathode ray tube provided with an optical element in accordance with the invention;

Fig. 1B is a cross-sectional view of a detail of Fig. 1A;

Fig. 2A is an example of a display device comprising a plurality of pixels
including an electrochromic element in accordance with the invention;

Fig. 2B is a further example of a display device comprising a plurality of
15 pixels including an electrochromic element in accordance with the invention;

Fig. 3 is a partly perspective view of an example of an electrochromic
element comprising an electrochromic layer in accordance with the invention;

Fig. 4 shows the transmission spectra, as a function of the wavelength λ
in the visible range, of an electrochromic element in the colored state which is made from
20 the known tungsten oxide and from tungsten oxide in accordance with the invention;

Figs. 5A and 5B show, in a C.I.E. 1931 color triangle, the color co-
ordinates of an optical element which comprises an electrochromic element of the known
tungsten oxide and of tungsten oxide in accordance with the invention, and

Figs. 6A and 6B show the negative logarithm of the transmission as a
25 function of the intercalated charge of electrochromic tungsten oxide in accordance with the
invention in different intercalation states.

The Figures are purely diagrammatic and not drawn to scale. Particularly
for clarity, some dimensions are exaggerated strongly. Similar components in the Figures
bear identical reference numerals, where possible.

30 Fig. 1A is a schematic, cut-away view of a display device comprising a
cathode ray tube (CRT) 1 having a glass envelope 2 including a display window 3, a cone 4
and a neck 5. An electron gun 6 for generating one or more electron beams is situated in
said neck. Said electron beam(s) is (are) focused on a phosphor layer 7 on the inner surface
of the display window 3 and is (are) deflected across said display window 3 in two mutually

perpendicular directions by means of a deflection coil system 8. On the outer surface, the display window 3 of the display device 1 is provided with an electrochromic element 9 in accordance with the invention. Preferably, the electrochromic element is directly provided on the outer surface of the display window of the display device (see Fig. 1A). In an alternative
5 embodiment, the optical element is provided on a (flat) so-called front panel which is arranged on the viewing side of the display device in front of the display window.

Such optical elements can also be used on the viewing side of display windows of other (flat) (picture) display devices, such as plasma display panels (PDPs) and liquid-crystal display devices (LCDs, LC-TVs and plasma-addressed LCDs) to improve the
10 contrast of the image reproduced.

Fig. 1B is a cross-sectional view of a detail of Fig. 1A, in which the phosphor layer 7 on the inner surface of the display window 3 comprises a regular pattern of (electro-)luminescent spots 19R, 19G, 19B. Said spots 19R, 19G, 19B each contain a suitable phosphor of the right color: red 19R, green 19G or blue 19B. Preferably, the outer surface
15 of the display window 3 is provided with an electrochromic element 9 having a variable transmission. Element 9 at least comprises an electrochromic layer 10 in accordance with the invention on the basis of tungsten oxide WO_x . One of the properties of the electrochromic element 9 is that the transmission properties in the visible range vary indirectly as a result of variations in ambient light (indirect response to a variation in light). The layer 10 may
20 comprise one or more layers.

In order to be able to react rapidly to variations in the intensity of ambient light, a change in the transmission of the electrochromic layer 10 of the electrochromic element 9 as a result of a variation in the intensity of ambient light, takes place in less than 5 minutes, preferably less than 1 minute. Preferably, the electrochromic layer 10 (in the state
25 in which the transmission of the layer is high) is insensitive to luminous flux densities below 10 lux, preferably below 100 lux.

Fig. 2A is a very schematic view of a display device comprising a plurality of pixels including an electrochromic element in accordance with the invention. In this example, the display device comprises an array of 5 x 7 pixels 41, 41', 41"; 42; 47
30 which are provided on a substrate 40 (for example a pyrex glass plate) and arranged in accordance with a regular (rectangular) pattern. Each one of the pixels comprises an electrochromic element with an electrochromic layer in accordance with the invention and is connected via conductor paths, which are not shown in Fig. 2A, to electric contacts 31, 31'; 36, 36' via which the desired voltage is applied across the electrochromic element. If a

voltage difference is applied across one of the electrochromic elements, the electrochromic layer switches to the colored state (color-neutral black/grey) or the electrochromic layer is decolorized to the bleached (transparent) state. In this manner, by simultaneously selecting a number of electrochromic elements all letters of the alphabet and the arabic numerals can be formed.

Fig. 2B shows an alternative display device comprising a plurality of pixels including an electrochromic element in accordance with the invention. In this example, the display device comprises an array of 7+1 pixels 51, 51', 51"; 55 which are provided on a substrate 50. Each one of the pixels comprises an electrochromic element having an electrochromic layer in accordance with the invention and is connected, via conductor paths which are not shown in Fig. 2B, to electric contacts 61, 61'; 66, 66' via which the desired voltage is applied across the electrochromic element. In this manner, by simultaneously selecting a number of the electrochromic elements 51, 51', 51" all arabic numerals, including a point (element 55) can be formed.

The advantage of the embodiments shown in Figs. 2A and 2B is that switching of the electrochromic elements can be brought about with relatively low voltages (± 1.5 V). A good memory effect of the electrochromic element enables, after switching of the relevant pixel, the voltage to be switched off until a subsequent display on the display device is desired. As the switching times between the bleached and the colored state are less than 1 minute, such displays can very suitably be used to display data-graphic information (for example in arrival or departure halls of railway stations or airports, or as means for displaying different messages/advertisements).

Fig. 3 is a very schematic, partly perspective view of an example of an electrochromic element 20 comprising an electrochromic layer 25 in accordance with the invention. Said electrochromic element includes two half cells, which are interconnected ("laminated") via an electrolyte 23. The first half cell comprises a transparent conductor 24, for example ITO (indium tin oxide) and an electrochromic layer 25 in accordance with the invention, which layer predominantly comprises a metal oxide of the group formed by tungsten oxide, molybdenum oxide, niobium oxide, manganese oxide and zirconium oxide, and which layer is also referred to as work electrode. In the example shown in Fig. 3, it is schematically indicated that the electrochromic layer 25 is composed of a plurality of sub-layers 25', 25", 25"', in which the oxygen content in accordance with the invention varies from sub-layer to sub-layer. Preferably, in particular, the transitions from one sub-layer to the next sub-layer exhibit a reduced oxygen content, and the central part of the sub-layers

comprises at least substantially stoichiometric WO_3 .

The second half cell comprises a transparent substrate 28, for example glass, which supports a transparent conductor 26, for example ITO, and a so-called ion storage layer 27, also referred to as counter electrode. A voltage difference is applied
5 between the transparent conductors 24 and 26 (typically ± 1.5 V). The counter electrode 27 generally is responsible only for storing and releasing guest ions, such as hydrogen ions (H^+) and alkali-metal ions, such as Li^+ ions and usually does not contribute, or only to a small extent, to the change in color of the electrochromic element (for example if the counter electrode 27 comprises the material cerium oxide (CeO_x)). The ion conductor is responsible
10 for a rapid transfer of the guest ions and, preferably, has a high resistance to electroconduction by electrons (in Fig. 3, the movement of the ions is indicated by an arrow). The metal oxide in the electrochromic layer 25 serves to ensure that the transmission properties, upon applying a voltage difference across the element, undergo a reversible change from (colorless) transparent to (color-neutral) dark-colored.

15 If the two half cells are laminated via a polymeric electrolyte 23, for example a mixture of poly-ethylene-oxide (PEO), poly-methyl-metha-acrylate (PMMA) and a specific quantity of LiClO_4 , the thickness of the polymeric electrolyte 23 is approximately 1-1000 μm . In a so-called "all solid-state" electrochromic element, the electrolyte 23 is formed by a (coating) layer of a transition metal, such as Ta_2O_5 or LiNbO_3 . In the case of a
20 solid-state electrochromic element, said element can be provided in the form of a system of (coating) layers on the substrate 28 by means of known techniques, and the thickness of the electrolyte is, for example, 0.3 μm . Said known deposition techniques include spinning, sol-gel processing, CVD (chemical vapor deposition), vapor deposition (PVD physical vapor deposition) and (reactive) sputtering, and combinations thereof.

25 Fig. 4 shows the transmission spectra (T in %), as a function of the wavelength λ (λ in nm) in the visible range, of an electrochromic element in the colored state, in which Figure, curve 1 shows the known tungsten oxide and curve 2 shows tungsten oxide in accordance with the invention. The known tungsten oxide (curve 1) exhibits a transmission spectrum with the characteristic deep-blue color ($T_{\text{max}} \approx 0.27$, $T_{\text{min}} \approx 0.04$,
30 $\Delta T_{\text{rel}} \approx 0.74$). In this example, the tungsten oxide WO_x in accordance with the invention (curve 2) has a $T_{\text{max}} \approx 0.14$, $T_{\text{min}} \approx 0.11$, so that $\Delta T_{\text{rel}} \approx 0.12$, which is below the upper limit of $\Delta T_{\text{rel}} < 0.35$ and below the preferred limit of $\Delta T_{\text{rel}} < 0.2$.

Fig. 5A shows in a C.I.E. 1931 color triangle, the color co-ordinates (x ; y) of an optical element comprising an electrochromic element, in which Figure,

curve 1 shows the known tungsten oxide and curve 2 shows the tungsten oxide in accordance with the invention. The numbers which correspond to the circles on the edge of the color triangle correspond to the wavelengths of monochromatic visible light in nm. The so-called "white" point (not shown in Fig. 5A) is the point in the center of the color triangle which corresponds to a color co-ordinate of (0.333; 0.333). For clarity, Fig. 5B shows a region in the color triangle around $0.2 \leq (x;y) \leq 0.4$ on an enlarged scale.

In Figs. 5A and 5B, the color points (open squares) situated on curve 1 correspond to the color co-ordinates of the known tungsten oxide. In the bleached state (indicated by b in curve 1), the color point of the known electrochromic WO_3 layer substantially coincides with the "white" point of the color triangle. During the application of the voltage difference across the known electrochromic layer (referred to as intercalating) the transmission of the WO_3 layer decreases and the layer assumes a dark-blue color (see "colored state", indicated by c in curve 1). In Figs. 5A and 5B, the color points (open circles) situated on curve 2 correspond to the color co-ordinates of the tungsten oxide in accordance with the invention. In the bleached state (indicated by b in curve 2), the color point of the electrochromic WO_3 layer in accordance with the invention substantially coincides with the "white" point of the color triangle. During the application of the voltage difference across the electrochromic layer in accordance with the invention (referred to as intercalating) the transmission of the WO_3 layer decreases and the color point remains in the so-called white region around the "white" point (see "colored state", indicated by c in curve 2).

The electrochromic layer in accordance with the invention is sufficiently color neutral at all stages if the electrochromic layer exhibits such a spectral characteristic that, as a result of the application of the voltage difference across the layer, color co-ordinates (x;y) of the electrochromic layer vary in such a manner that a line interconnecting the color co-ordinates (x;y) in a C.I.E. 1931 color triangle is partly situated in an elliptical area with middle point (0.333; 0.333) in the color triangle, which ellipse has a long axis and a short axis, with the long axis terminating in (0.30; 0.28) and (0.36; 0.38), and the ratio of the length of the long axis to the length of the short axis ranging between 2 and 3.

Fig. 6A shows the negative logarithm of the transmission (-log T) as a function of the intercalated charge q (q in mC) of the electrochromic tungsten-oxide WO_x in accordance with the invention. Li^+ is intercalated into the tungsten oxide until the grey point is reached. The transmission of the electrochromic layer is determined at the following wavelengths $\lambda_1 = 400$ nm (open triangles), $\lambda_2 = 600$ nm (open squares), and $\lambda_3 = 1000$ nm

(open circles). The three transmission curves substantially coincide at a point (the so-called "grey point") indicated by $q_{cn} \approx 75$ mC, at which value the layer is (perfectly) color neutral (cn). The maximum absorption in the electrochromic layer occurs at an (imaginary) vertical line which is indicated in Fig. 6A by $q_{max} \approx 50$ mC, at which value (after conversion)

5 $T_{max} \approx 0.45$ and $T_{min} \approx 0.26$, so that $\Delta T_{rel} \approx 0.27$, which is situated below the upper limit of $\Delta T_{rel} < 0.35$.

If the electrochromic layer is subject to intercalation more than once, the grey point shifts to a lower value of the intercalated charge and the color neutrality of the electrochromic layer in accordance with the invention is improved throughout the charged

10 region. Fig. 6B shows the same dependencies as Fig. 6A, in which former case the film is once again intercalated to a value of 100 mC. This results in a color-neutral point ("grey point") which is indicated by $q_{cn} \approx 60$ mC. The maximum absorption in the electrochromic layer occurs at an (imaginary) vertical line which is indicated, in Fig. 6B, by $q_{max} \approx 40$ mC, at which value (after conversion) $T_{max} \approx 0.50$ and $T_{min} \approx 0.35$, so that $\Delta T_{rel} \approx 0.18$, which

15 is situated below the preferred limit of $\Delta T_{rel} < 0.20$.

Example

An example of an electrochromic element 20 is formed by the following system of layers (see Table I and Fig. 3):

- 20 a so-called "all solid-state" electrochromic element 20 comprising five layers, namely:
- a first transparent conductor 24 of ITO (indium tin oxide) (thickness $\approx 0.3 \mu\text{m}$, refractive index ≈ 2.0),
 - a work electrode 25 of WO_x in accordance with the invention (thickness $\approx 0.4 \mu\text{m}$, refractive index ≈ 2.0),

25

 - a solid-state electrolyte 23 of Ta_2O_5 (thickness $\approx 0.2 \mu\text{m}$, refractive index ≈ 2.0),
 - a counter electrode 27 of NiO (thickness $\approx 0.3 \mu\text{m}$, refractive index ≈ 2.0),
 - a second transparent conductor 26 of ITO (indium tin oxide)

30 (thickness $\approx 0.3 \mu\text{m}$, refractive index ≈ 2.0).

Table I Electrochromic element

substrate	ITO	NiO	Ta ₂ O ₅	WO ₃	ITO	air
n ~ 1,5	n ~ 2	n ~ 2	n ~ 2	n ~ 2	n ~ 2	n ~ 1
	~0,3 μm	~0,3 μm	~0,2 μm	~0,4 μm	~0,3 μm	

5

To reduce undesirable specular reflections, an anti-reflective layer of Al₂O₃ (optical thickness $\approx 1/4\lambda$, geometric thickness $\approx 0.1 \mu\text{m}$) may be situated (not shown in Fig. 2) between the electrochromic element 20 and the substrate 28. Further undesirable reflections can be precluded by providing a further anti-reflective layer of SiO₂ (optical thickness $\approx 1/4\lambda$) (not shown in Fig. 3) on the outer surface of the electrochromic element 20.

The electrochromic element is preferably provided on the viewing side of a (display) window (substrate) of a display device. The optical element described in this example is preferably provided by means of sputtering, and the above-mentioned (coating) layers being successively deposited on the substrate in one coating operation. In a sputtering process, a mixture of ions (argon, oxygen; at a characteristic pressure of approximately 1 Pa) is used to bombard a so-called target (for example metallic tungsten, tantalum, nickel, etc.), from which small particles (atomic scale) are released whose energy content is sufficient to reach the substrate (for example the window of a display device). In general, the substrate does not have to be heated to obtain layers having the desired mechanical properties. Oxidation of the layers is brought about by admitting the proper quantity of oxygen to the evacuated deposition chamber during sputtering (reactive sputtering). The target may alternatively consist of metal oxides.

The construction of an electrochromic element is similar to that of a battery, that is, they both comprise two electrodes and an electrolyte sandwiched therebetween (3 active layers). The transmission of the electrochromic element is controlled by applying a voltage difference across the element ($\pm 1.5 \text{ V}$). The transmission can be controlled via a light sensor (automatically via a control circuit) or via a remote control operated by the viewer. An electrochromic element can react to light originating from a natural light source as well as to light originating from an artificial light source. If the display device is in the off position (stand-by), the electrochromic element can be set at a specific transmission (for example a minimum transmission to improve the appearance of the display device).

The overall thickness of the electrochromic element 20 described in this example is approximately $1.5 \mu\text{m}$. The overall transmission T_t of the electrochromic element 20 varies in the range from 0.1 to 0.9 ($10 \leq T_t \leq 90\%$). To make the best use of the extremely great dynamic range of the electrochromic element when it is used in (picture) display devices, it is desirable that the transparency of the substrate (display window) should be as high as possible. To achieve this, the transmission of the (display) window of the (picture) display device comprising the electrochromic element is preferably higher than 90%.

It will be obvious that, within the scope of the invention, many variations are possible to those skilled in the art. For example, the electrochromic element can also be combined with anti-reflective, anti-scratch and/or anti-static layers.

Claims:

1. An electrochromic element (20) comprising a substrate (28) and an electrochromic layer (25) having a thickness d on the basis of a metal oxide selected from the group consisting of tungsten oxide, molybdenum oxide, niobium oxide, manganese oxide and zirconium oxide or combinations thereof, the transmission properties of the electrochromic layer in the visible range being governed by an applied voltage difference across the electrochromic layer, characterized in that the oxygen content in the electrochromic layer (25) varies across the thickness of said electrochromic layer.
2. An electrochromic element as claimed in claim 1, characterized in that the variation of the oxygen content in the electrochromic layer (25) comprises at least two local maxima and a local minimum.
3. An electrochromic element as claimed in claim 1 or 2, characterized in that the electrochromic layer (25) comprises a plurality of sub-layers (25', 25'', 25'''), with the variation of the oxygen content in the electrochromic layer (25) occurring predominantly at the location of transitions between two sub-layers.
4. An electrochromic element as claimed in claim 1, characterized in that the metal oxide comprises tungsten oxide WO_x .
5. An electrochromic element as claimed in claim 4, characterized in that upon the application of the voltage difference, the electrochromic layer (25) exhibits such a spectral characteristic that the difference between the maximum transmission T_{max} and the minimum transmission T_{min} of the electrochromic element (20) in the visible range is less than 35% of the sum of T_{max} and T_{min} ,

$$\frac{T_{max} - T_{min}}{T_{max} + T_{min}} \leq 0,35.$$
6. An electrochromic element as claimed in claim 4 or 5, characterized in that the oxygen content of tungsten oxide WO_x ranges between $x = 0$ and $x = 3$.
7. A display device (1) comprising a display screen (3) and an electrochromic element (9; 20), as claimed in claim 1.
8. A display device comprising a plurality of pixels (41, 41', 41"; 42, 47),

which pixels comprise an electrochromic element (20) as claimed in claim 1.

9. A method of manufacturing an electrochromic layer (25) on the basis of a metal oxide selected from the group formed by tungsten oxide, molybdenum oxide, niobium oxide, manganese oxide and zirconium oxide, or combinations thereof, the transmission
5 properties of the electrochromic layer in the visible range being governed by an applied voltage difference across the electrochromic layer, said electrochromic layer being provided by means of a sputter-deposition process in an evacuated chamber, characterized in that during the provision of the electrochromic layer (25), the oxygen content in the chamber is varied.

10 10. A method as claimed in claim 9, characterized in that, during the deposition process, the oxygen content is varied in such a manner that the variation of the oxygen content in the electrochromic layer (25) comprises at least two local maxima and a local minimum.

11. A method as claimed in claim 9 or 10, characterized in that the
15 electrochromic layer (25) provided during the deposition process comprises tungsten oxide WO_x .

12. A method as claimed in claim 9 or 10, characterized in that during the deposition process, a plurality of sub-layers (25', 25'', 25''') is formed, with the variation of the oxygen content in the electrochromic layer (25) occurring predominantly at the location
20 of transitions between two sub-layers.

1/6

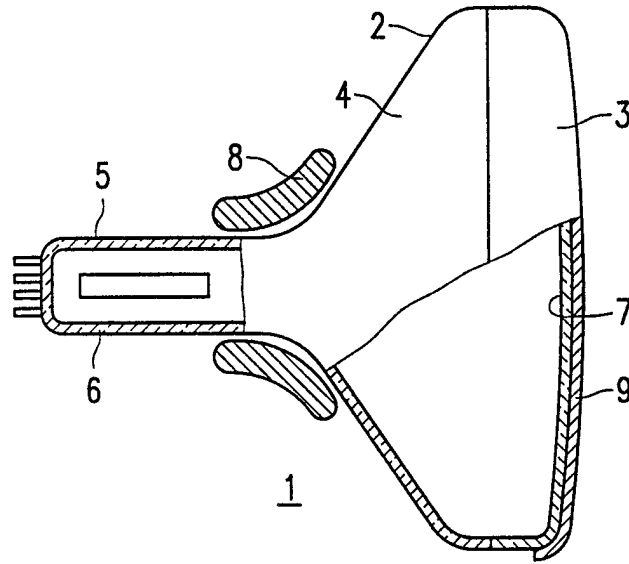

FIG. 1A

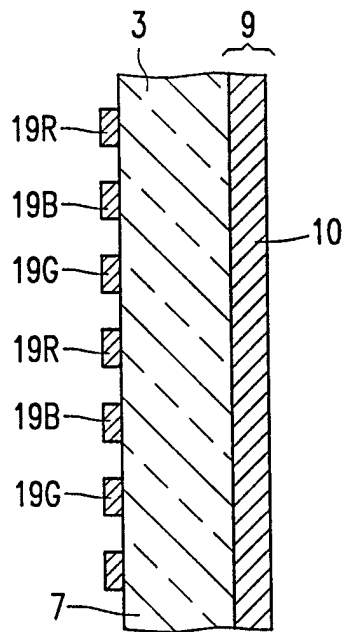

FIG. 1B

2/6

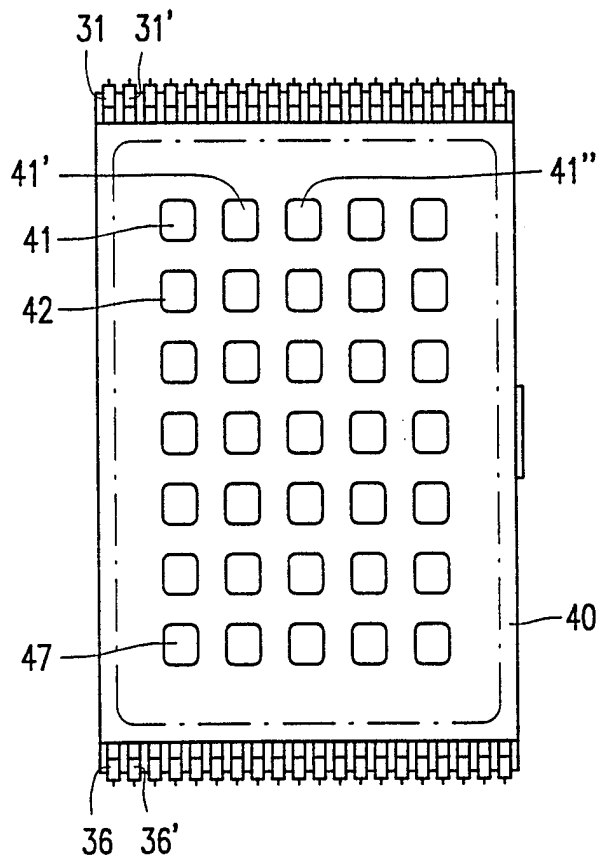

FIG. 2A

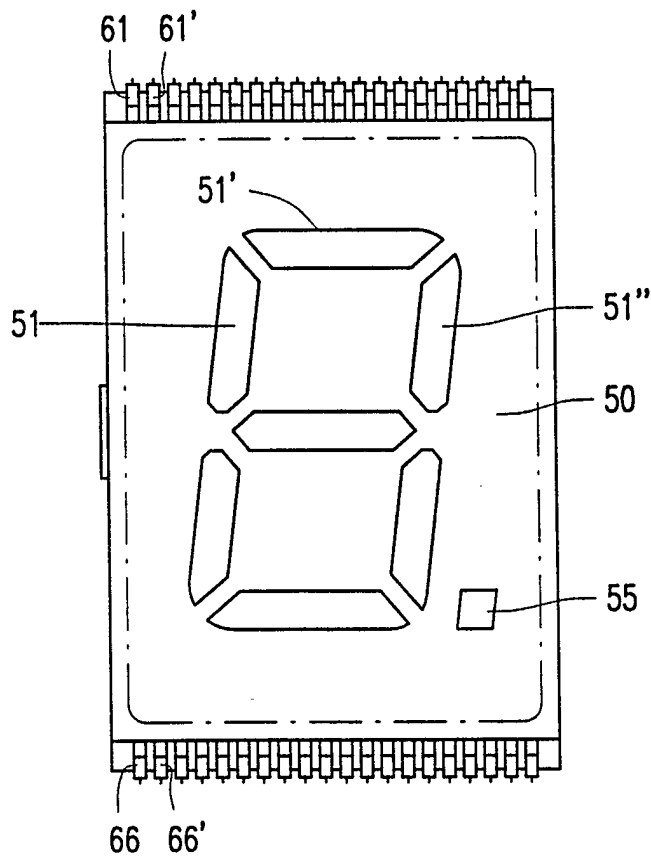

FIG. 2B

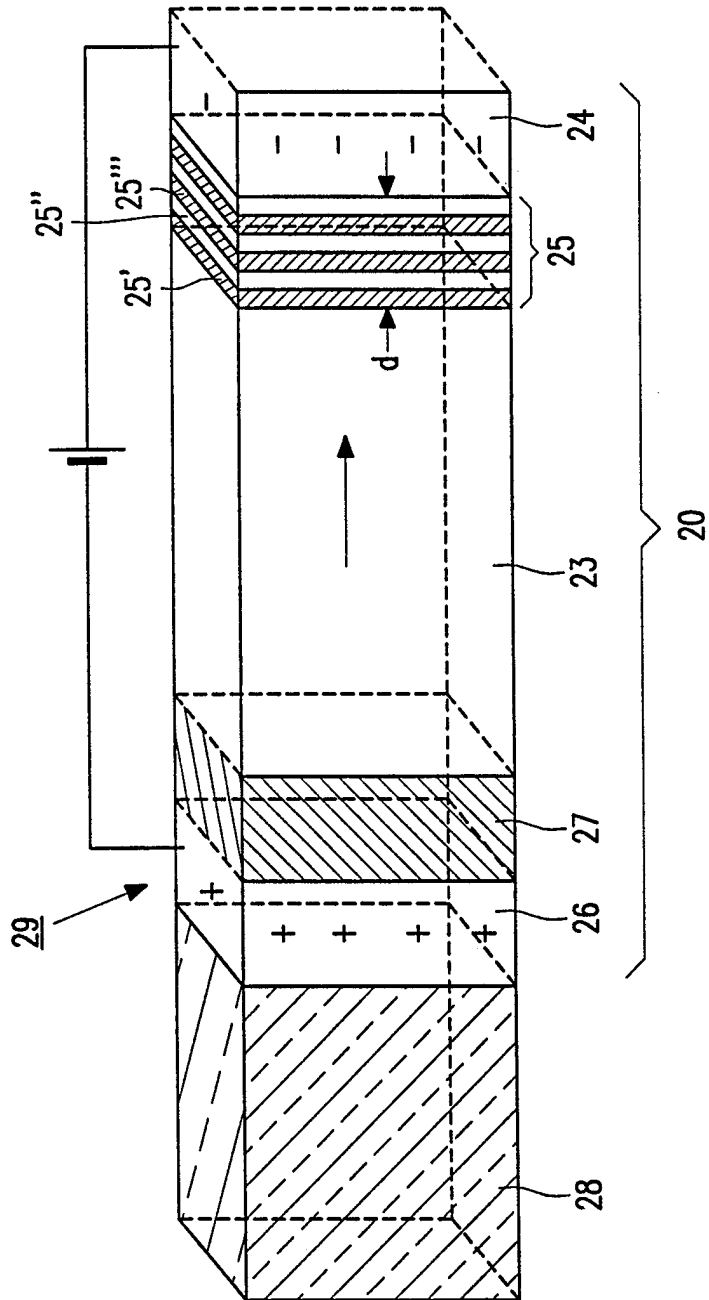

FIG. 3

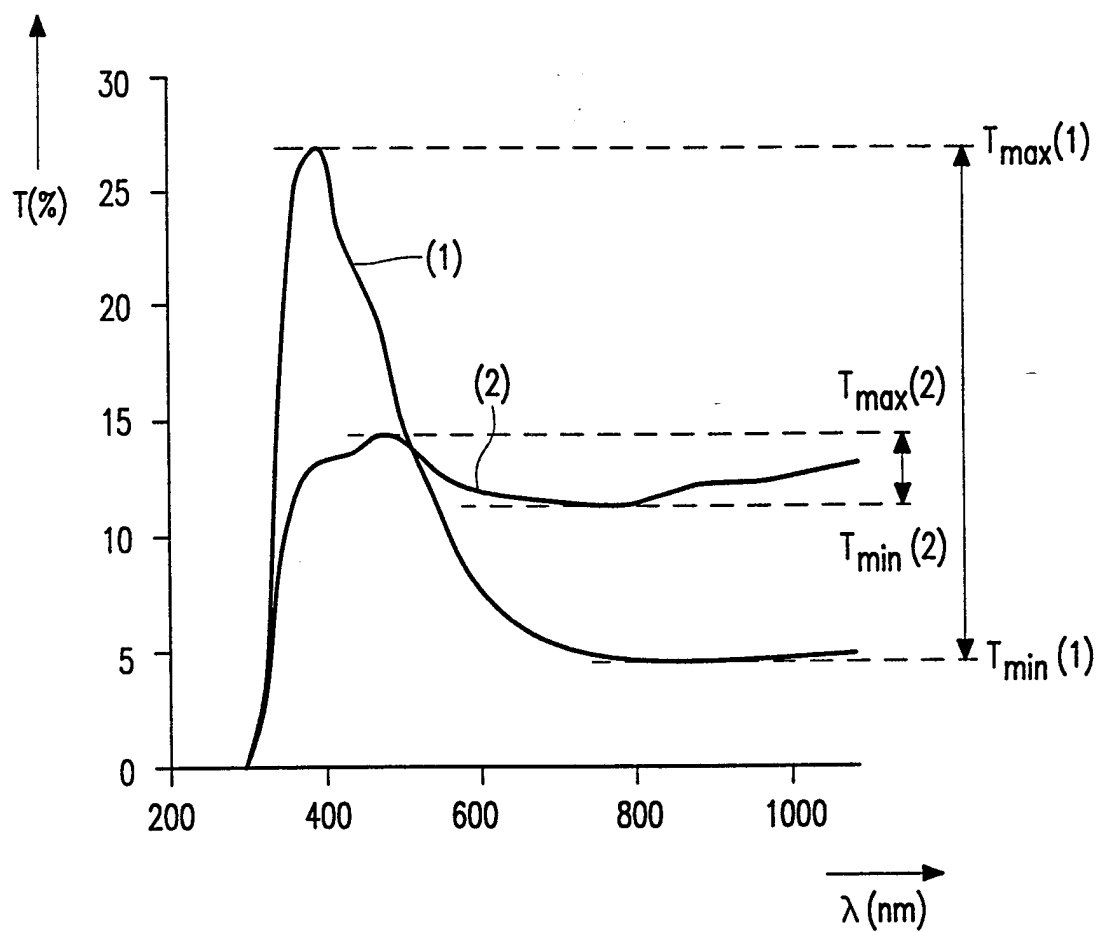

FIG. 4

5/6

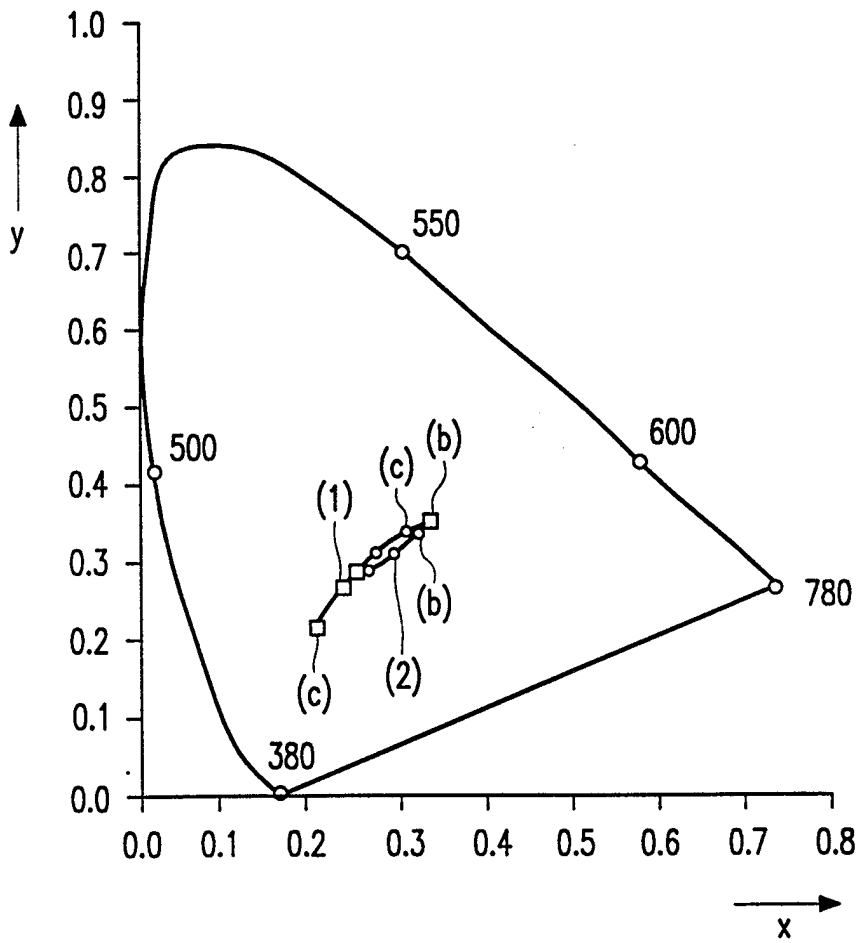

FIG. 5A

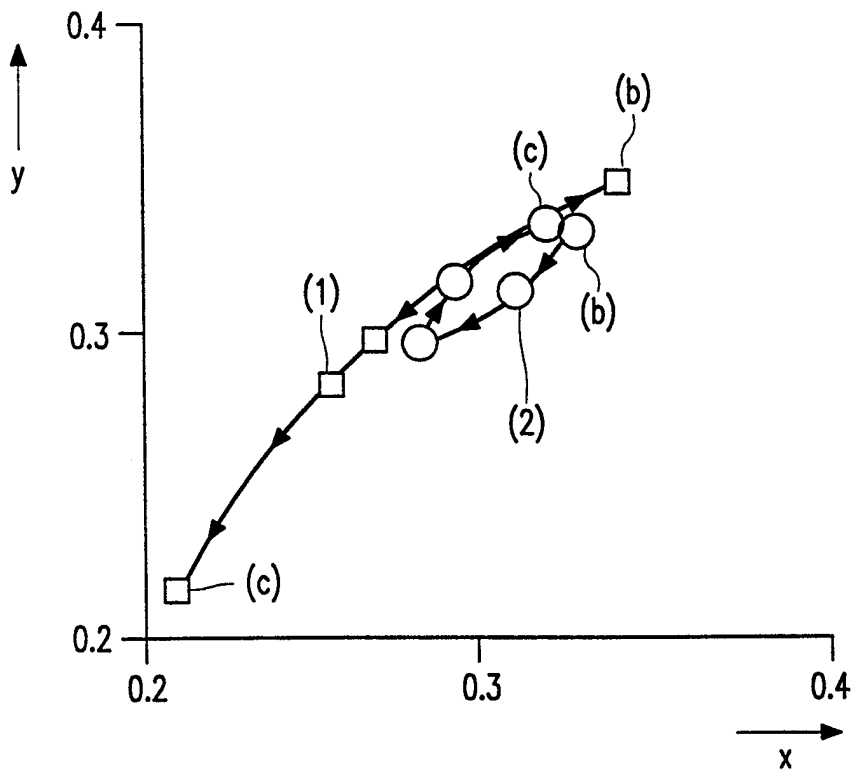

FIG. 5B

6/6

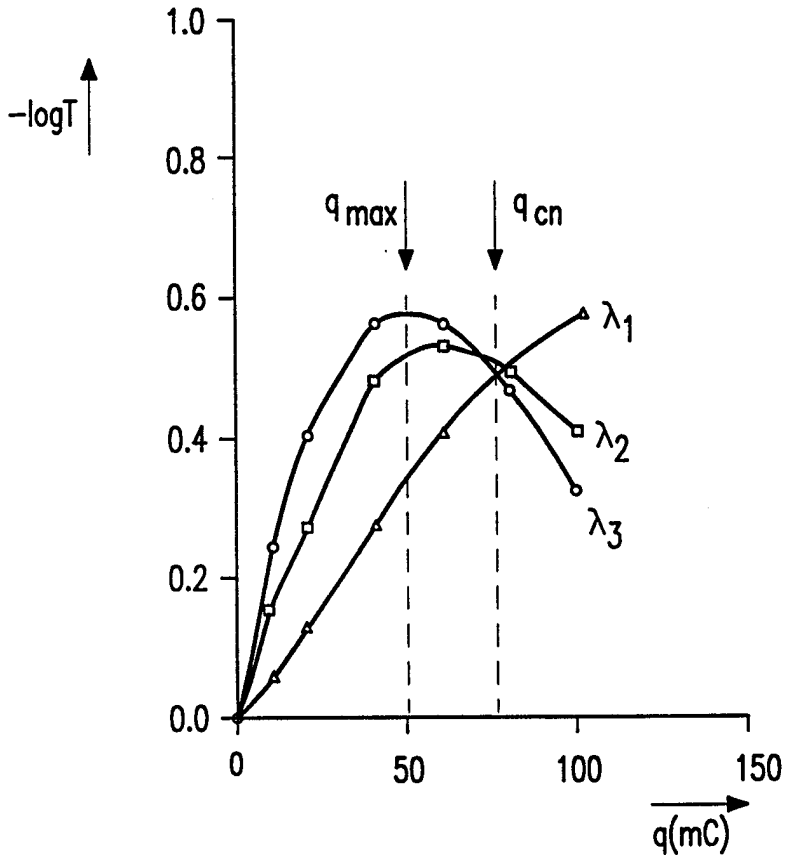

FIG. 6A

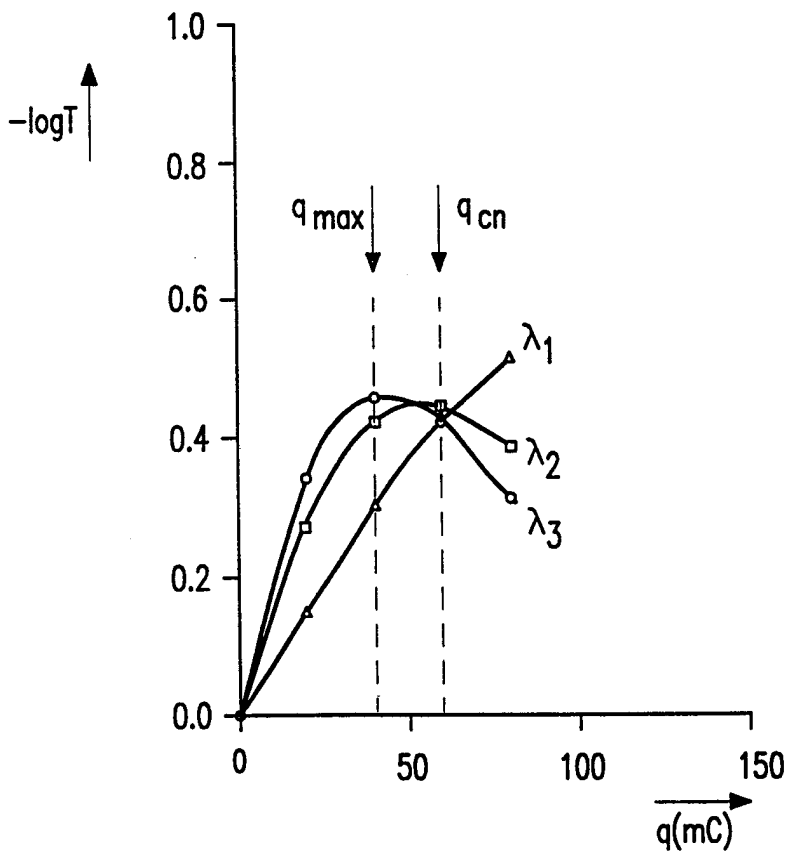

FIG. 6B

INTERNATIONAL SEARCH REPORT

International application No.

PCT/IB 98/00329

A. CLASSIFICATION OF SUBJECT MATTER

IPC6: G02F 1/153

According to International Patent Classification (IPC) or to both national classification and IPC

B. FIELDS SEARCHED

Minimum documentation searched (classification system followed by classification symbols)

IPC6: G02F

Documentation searched other than minimum documentation to the extent that such documents are included in the fields searched

SE,DK,FI,NO classes as above

Electronic data base consulted during the international search (name of data base and, where practicable, search terms used)

WPI

C. DOCUMENTS CONSIDERED TO BE RELEVANT

Category*	Citation of document, with indication, where appropriate, of the relevant passages	Relevant to claim No.
X	US 4960324 A (FRANKLIN I. BROWN), 2 October 1990 (02.10.90), column 4, line 8 - column 9, line 13, abstract	1,4,6,7,8
Y	--	9,11
Y	US 5520851 A (PHILLIP C. YU ET AL), 28 May 1996 (28.05.96), column 2, line 35 - column 6, line 58, abstract	9,11
A	US 4508792 A (KAZUYA ISHIWATA), 2 April 1985 (02.04.85), column 1, line 65 - column 3, line 17, abstract	1-12

 Further documents are listed in the continuation of Box C. See patent family annex.

* Special categories of cited documents:

"A" document defining the general state of the art which is not considered to be of particular relevance

"E" earlier document but published on or after the international filing date

"L" document which may throw doubts on priority claim(s) or which is cited to establish the publication date of another citation or other special reason (as specified)

"O" document referring to an oral disclosure, use, exhibition or other means

"P" document published prior to the international filing date but later than the priority date claimed

"T" later document published after the international filing date or priority date and not in conflict with the application but cited to understand the principle or theory underlying the invention

"X" document of particular relevance: the claimed invention cannot be considered novel or cannot be considered to involve an inventive step when the document is taken alone

"Y" document of particular relevance: the claimed invention cannot be considered to involve an inventive step when the document is combined with one or more other such documents, such combination being obvious to a person skilled in the art

"&" document member of the same patent family

Date of the actual completion of the international search

24 July 1998

Date of mailing of the international search report

27-07-1998

Name and mailing address of the ISA/
Swedish Patent Office
Box 5055, S-102 42 STOCKHOLM
Facsimile No. +46 8 666 02 86

Authorized officer

Karin Säfsten
Telephone No. +46 8 782 25 00

INTERNATIONAL SEARCH REPORT

International application No.

PCT/IB 98/00329

C (Continuation). DOCUMENTS CONSIDERED TO BE RELEVANT

Category*	Citation of document, with indication, where appropriate, of the relevant passages	Relevant to claim No.
D,A	US 4824222 A (MINO GREEN), 25 April 1989 (25.04.89), column 2, line 65 - column 4, line 50, abstract -----	1-12

INTERNATIONAL SEARCH REPORT

Information on patent family members

30/06/98

International application No.

PCT/IB 98/00329

Patent document cited in search report	Publication date	Patent family member(s)	Publication date
US 4960324 A	02/10/90	CA 1318386 A	25/05/93
		DE 68908326 T	09/12/93
		EP 0363044 A,B	11/04/90

US 5520851 A	28/05/96	EP 0697119 A	21/02/96
		JP 8262502 A	11/10/96
		US 5618390 A	08/04/97
		WO 9513562 A	18/05/95

US 4508792 A	02/04/85	DE 3341384 A,C	17/05/84
		JP 59090821 A	25/05/84

US 4824222 A	25/04/89	DE 3629879 A,C	05/03/87
		FR 2597622 A	23/10/87
		GB 2183860 A,B	10/06/87
		JP 2567226 B	25/12/96
		JP 62113721 A	25/05/87
