

[54] METHOD AND APPARATUS FOR DISPENSING A FLUIDIZABLE SOLID FROM A PRESSURE VESSEL

1,809,436 6/1931 Carman .
1,921,060 8/1933 Williams .
1,922,037 8/1933 Hardy .
1,949,731 3/1934 Soldatoff .
1,968,917 8/1934 Soldatoff .

[75] Inventor: Walter Meichsner, Krefeld, Fed. Rep. of Germany

(List continued on next page.)

[73] Assignee: Thyssen Aktiengesellschaft vorm August Thyssen-Hutte AG, Duisburg, Fed. Rep. of Germany

FOREIGN PATENT DOCUMENTS

183097 9/1955 Austria .
194423 1/1958 Austria .
207395 1/1960 Austria .
253417 5/1963 Austria .

(List continued on next page.)

[21] Appl. No.: 427,083

[22] Filed: Sep. 29, 1982

OTHER PUBLICATIONS

Der IRSID-Staubzuteiler für den OLP-Konverter (Siemens & Halske AG).

La Technique Moderne 55, 11 505-11 (Nov. 1963) "The Utilization of Pulverulent Materials in Iron Metallurgy", C. Roederer and J. Rouanet.

(List continued on next page.)

Related U.S. Patent Documents

Reissue of:

[64] Patent No.: 3,807,602
Issued: Apr. 30, 1974
Appl. No.: 270,397
Filed: Jul. 10, 1972

[51] Int. Cl.³ B67D 5/08

[52] U.S. Cl. 222/1; 222/77;
222/630; 406/12; 406/23

[58] Field of Search 222/1, 77, 193, 52,
222/55, 56, 630, 637; 406/10, 12, 19, 23

Primary Examiner—Joseph J. Rolla
Attorney, Agent, or Firm—Sprung, Horn, Kramer & Woods

[57] ABSTRACT

An improvement in a process for dispensing a fluidizable solid from the lower portion of a pressure vessel equipped with a weighing device, a closable supply, a discharge, and a source of three gas flows, a first of which is applied within the vessel at a level above the solid to be fluidized, a second of which is applied within said vessel in a lower portion thereof, and a third of which is applied within the discharge orifice of the vessel, which discharge orifice terminates in a chamber, which improvement involves determining the amount of solid dispensed and determining the throughflow of gas in relationship to the amount of solid dispensed to maintain a constant gas/solid ratio while maintaining the pressures such that the pressure applied to the lower portion of the vessel is greater than the pressure applied at a level above of the solids which, in turn, is greater than the pressure applied to the discharge orifice, all of which are greater than the pressure maintained within the chamber, and an apparatus for carrying out the process embodying control devices to maintain the desired constant predetermined gas/solid ratio.

[56] References Cited

U.S. PATENT DOCUMENTS

49,052 7/1865 Bessemer .
52,656 2/1866 Kerpely .
94,994 9/1869 Bessemer .
193,551 7/1877 Reese .
905,948 12/1908 Stromborg .
987,704 3/1911 Deemer .
1,038,781 9/1912 Myles et al. .
1,151,332 8/1915 Baggaley .
1,203,703 11/1916 Chevalier .
1,231,327 6/1917 Brauchler .
1,484,465 2/1924 Billings .
1,491,433 4/1924 Stebbins .
1,505,281 8/1924 Nagelvoort .
1,541,778 6/1925 Agricola .
1,587,600 6/1926 Nielsen .
1,646,728 10/1927 Evans .
1,666,477 4/1928 Stebbins .
1,709,389 4/1929 Davis .
1,785,503 12/1930 Spring .

89 Claims, 3 Drawing Figures

FOREIGN PATENT DOCUMENTS

1189453 11/1965 Fed. Rep. of Germany .
 1408188 10/1968 Fed. Rep. of Germany .
 1433691 3/1969 Fed. Rep. of Germany .
 1292693 4/1969 Fed. Rep. of Germany .
 1803377 5/1969 Fed. Rep. of Germany .
 1817507 8/1969 Fed. Rep. of Germany .
 1508208 10/1969 Fed. Rep. of Germany .
 2032845 2/1971 Fed. Rep. of Germany .
 1758835 3/1971 Fed. Rep. of Germany .
 2106536 9/1971 Fed. Rep. of Germany .
 1802991 2/1972 Fed. Rep. of Germany .
 1642954 3/1972 Fed. Rep. of Germany .
 2205090 9/1972 Fed. Rep. of Germany .
 2219818 10/1973 Fed. Rep. of Germany .
 2153379 11/1973 Fed. Rep. of Germany .
 2209902 1/1975 Fed. Rep. of Germany .
 1912733 10/1979 Fed. Rep. of Germany .
 457645 9/1913 France .
 1091102 4/1955 France .
 1219334 5/1960 France .
 1238314 7/1960 France .
 1250107 11/1960 France .
 1280116 11/1961 France .
 1467158 12/1966 France .
 1596638 7/1970 France .
 2051745 9/1971 France .
 2087972 7/1972 France .
 252267 3/1927 Italy .
 22204 7/1970 Japan .
 26612 8/1971 Japan .
 100311 12/1973 Japan .
 31518 8/1974 Japan .
 183547 5/1963 Sweden .
 183691 5/1963 Sweden .
 211838 8/1966 Sweden .
 341412 12/1971 Sweden .
 6904 5/1972 Sweden .
 192466 11/1974 Sweden .
 371469 10/1963 Switzerland .
 2243 of 1879 United Kingdom .
 622419 6/1949 United Kingdom .
 800877 9/1958 United Kingdom .
 818697 8/1959 United Kingdom .
 829274 3/1960 United Kingdom .
 837587 6/1960 United Kingdom .
 892550 3/1962 United Kingdom .
 896539 5/1962 United Kingdom .
 915637 1/1963 United Kingdom .
 918104 2/1963 United Kingdom .
 940506 10/1963 United Kingdom .
 943810 12/1963 United Kingdom .

954838 9/1965 United Kingdom .
 1014827 12/1965 United Kingdom .
 1037518 3/1963 United Kingdom .
 1046675 10/1966 United Kingdom .
 1073864 6/1967 United Kingdom .
 1164026 9/1969 United Kingdom .
 1223385 2/1971 United Kingdom .
 1372672 11/1974 United Kingdom .
 1434650 5/1976 United Kingdom .
 1435189 5/1976 United Kingdom .
 1450013 9/1976 United Kingdom .
 1479222 7/1977 United Kingdom .
 1556703 11/1979 United Kingdom .

OTHER PUBLICATIONS

"Applications en Aciérie Électrique de la Technique IRSID d'Insufflation de Matières Pulvérulentes", *Revue de Metallurgie*, Sep. 1963, by A. De Lavareille, J. Rauguin, P. Vayssiere, B. Trentini, with translation.
 "Calcium Carbide Injection—A New Foundry Tool", *American Foundryman*, Apr. 1954, vol. 25, No. 4, pp. 34-44, by H. E. Henderson and J. M. Crockett.
 Polysius 22—Desulphurization Plants for Pig Iron Using the Dipped Lance, Dr.—Ing. H. Klein.
 "Erfahrungen bei der Nachentschwefelung von Roheisen", *Stahl und Eisen*, Heft 6, 89, Mar. 20, 1969, by Von Hans-Peter Schulz, with side-by-side translation.
 Electric Furnace Proceedings, vol. 24, Phila., 1966, "Desulphurization Prior to the Boil" by Charles W. Briggs.
Journal of the Iron and Steel Institute, vol. 204, Jan. 1966, Part 1, "Effect of Calcium Carbide on Desulphurization Kinetics", pp. 226-229, by P. A. Hitchcock and A. Mitchell.
 "Entschwefelung des Stahls durch Einblasen von pulverformigen Reaktionsmitteln", A. S. Tumarev, A. H. Urazgil Dier and L. A. Panjusin.
Aufbereitungs-Technik, Nr. 10, pp. 603-613, by Dipl.—Ing. M. Weber.
 Leitner-Plöckinger "Edelstahlerzeugung", pp. 209, 210, 255, 681, and 682.
 von Helmut Knüppel, "Desoxydation und Vakuumbehandlung von Stahlschmelzen" 1970, pp. 62/69 and 275-283.

(List continued on next page.)

- von Bernhard Osann "Lehrbuch der Eisenhüttenkunde" 1921, pp. 540-545 and 1017-1022.
- "Die Physikalische Chemie der Eisen und Stahlerzeugung" 1964, pp. 256 and 260-261 and 328-329.
- "SKW-Kundeninformation", No. 4, Jan. 1972, pp. 2-10.
- "Stahl und Eisen" 1972, pp. 784-789 and pp. 1091-1092.
- Von E. Kudielka "Kalzium bei der Herstellung von Stahl and Eisen" Radex-Rundschau, 1965, issue 2, pp. 483-486.
- Von E. K. Modl "Die Anwendung von Spülgas- und Einblaseverfahren in der Giesserei" Jahrgang 48, issue 21, Oct. 19, 1961, pp. 639-647.
- Von Nils. F. Grevillius, Lars-Erik Carlsson and Lars Hellner, "Neues Stahleentschwefelungsverfahren" Neue Hütte 16 Jg. issue 2, Feb. 1971, pp. 72-77.
- Von W. Maschlanka, Kehl am Rhein, H. Knahl and A. Freissmuth, "Desulfurization of Pig Iron by Blowing in Calcium Carbide and Calcium Cyanamide with Additives", Radex-Rundschau, vol. 5, 1970, pp. 314-323 and English Translation thereof.
- Von Manfred Wahlster, Hermann Maas, Horst Abratis and Alok Choudhury "Reaction zwischen feuerfesten Stoffen des Systems $\text{SiO}_2\text{-Al}_2\text{O}_3$ und Manganhaltigen Eisenschmelzen" Archiv für das Eisenhüttenwesen issue 1, Jan. 1970, pp. 37-42.
- "Essais de desulfuration de la fonte liquide par injection de carbure de calcium pulvérisé" Tetsu to Hagane, Mar. 1955, pp. 193-195.
- Kiichi Narita, Akitsu Tomita, Yasuo Hirooka and Yoshitomo Satoh "Desulphurization of Molten Pig Iron by Means of Injection Method" Tetsu-to-Hagane, Journal of the Iron and Steel Institute of Japan, No. 13, vol. 56, Nov. 1970, pp. 1602-1612 (pp. 28-38).
- Von M. Wahlster, A. Choudhury, A. Knahl and A. Freissmuth "Die Wirkung Kalziumhaltiger Legierungen auf Desoxydation, Entschwefelung und mechanische Eigenschaften von Feinkornbaustahl" Radex-Rundschau, 1969, Issue 2, pp. 478-494.
- Von Rolf Ebert and Winfried Wenzel "Versuche zur Nachbehandlung von früssigem Roheisen" Neue Hütte, Issue 1, Nov. 1962, pp. 665-670.
- Von Bogdandy, Rutsch and Stranski "Gasaustausch Zwischen Blasen und Gaslosenden Flüssigkeiten" Chemie-Ing. Tech. 31, Jahrg. 1959, Nr. 9. 580-582.
- Werner Coupette "Die Vakuum-Behandlung des Flüssigen Stahles" Rudolf A. Lang Verlag, Wiesbaden, Esch/Taunus, 1967, pp. 128-133.
- "Hand Book of Iron and Steel" Fig. 8.124 in page 668, printed Mar. 1971 by Maruzen pp. 16, 17, 668-669-and partial translation.
- Aikoh Co., Ltd. "Progress in Processes for Melting Steel under Vacuum and for Degasifying under Vacuum" printed by Japanese Iron and Steel Association, 1969, pp. 147-157.
- Aikoh Co., Ltd. "Iron & Steel", p. 85, No. 3, vol. 55, 1969.
- Aikoh Co., Ltd. "Manufacture of Cast Iron and Steel" Table 10.4 in page 458, printed by Yohkendo, 1961, pp. 1, 458-459, 552 and partial translation.
- S. Kobayashi, "On the Deoxidation of a Liquid Iron with Argon-Calcium Bubbles", Iron and Steel, No. 8, vol. 56, 1970, pp. 998-1013.
- H. Schrewe and G. Diederich "Operating Results of Wide Slab Row Casting Plants" Journal of the West of Scotland Iron and Steel Institute" Paper No. 596, Mar. 27, 1969, pp. 33-64.
- Bernard Trentini, Pierre Vayssiere, Antoine de Lava-reille, and Jean Raguin "IRSID Powder Blowing Techniques Applied to Electric Steel-Making" Proceedings of Electric Furnace Conference, 1963, pp. 28-42.
- E. F. Kurzinski, Mktg. Mgr., Metals and Mining Industries, Fischer & Porter Co., Warminster, Pa. "Desulfurization of Iron-Status and Evaluation" Apr. 1976, pp. 00042-00054.
- Eckehard Forster, Wilhelm Klapdar, Helmut Richter, Heinrich-Wilhelm Rommerswinkel, "Deoxidation and Desulphurisation by Blowing of Calcium Compounds into Molten Steel and Its Effects on the Mechanical Properties of Heavy Plates" Stahl & Eisen 94 (May 23, 1974) No. 11, pp. 474-485.
- Heinrich-Wilhelm Rommerswinkel, "Untersuchung Zum Ablauf der Desoxydation und Entschwefelung Beim Einblasen Von Kalziumkarbid in Stahlschmelzen" Jul. 9, 1973, pp. 1-31 plus charts etc.
- Robert C. Weast, and Melvin J. Astle "CRC Handbook of Chemistry and Physics" p. d-221 "Vapor Pressure of the Elements" Rudolf Loebel CRC Press, Inc. Boca Raton, Fla. 33431.
- J. W. Menter "The Heterogeneity of Steel" Journal of the Iron and Steel Institute, Apr. 1971, pp. 249-263.
- B. Trentini, P. Vayssiere, and C. Roederer "OLP Steel-making Recent Studies and Industrial Progress" Journal of Metals, Jun. 1961, pp. 418-421.
- B. Trentini and M. Allard, "Refining Pig-Iron with Oxygen and Lime Powder" IRSID's Oxygene-Lance-Poudre (OLP) Process" Iron and Coal Trades Review, Oct. 10, 1958, pp. 871-874.
- B. Trentini and M. Allard "O.L.P.: Oxygen, Lime-- Powder Injection a New Steelmaking Process" Journal of Metals, Jul. 1958, pp. 466-470.
- B. Trentini, P. Vayssiere, and C. Roederer "Technology and Metallurgy of the OLP Process" Journal of

- Metals, Aug. 1962, pp. 579-583, No. 8, 14.
- SKW Trostberg AG, May 14, 1971 Proceedings and translation, (Certified) pp. 33-45; 46-63; 97-116.
- H. J. Langhammer and D. Danckert; "Comparison of Processes for Continuous and Discontinuous Desulphurization with Different Desulphurizing Agents" Radex-Rundschau, Issue 1, 1972, pp. 3-26 with English version.
- S. D. Baumer and P. M. Hulme "Desulphurizing Molten Iron with Calcium Carbide" Journal of Metals, Apr. 1951-pp. 313-318.
- G. P. Dahm, H. C. Barnes, and C. E. Bieniosek, Progress Report "Fluidization-Injection Process for Desulphurizing and Upgrading Cast Iron" Trans. Amer. Foundrym. Soc. 63 (1955) pp. 511-523.
- Daniel W. Watkins and J. R. McFarland "Desulphurization of Blast Furnace with Injected Calcium Carbide" Proc. Blast Furn. Coke Ovens Raw Materials Comm. AIME, vol. 15, (1956) pp. 138-147.
- C. E. Wood, E. P. Barret and F. W. Holbrook "Desulphurization of Pig Iron with Calcium Carbide" Transactions of the American Institute of Mining and Metallurgical Eng. vol. 140, Iron and Steel Div., 1940, pp. 87-105.
- J. V. Harding and C. N. Walters, "Injection of Powders into Molten Metals with Inert Gases (British Investigations and Installations)" Steel & Coal, Jun. 29, 1962, No. 72, pp. 1243-1249.
- P. K. Chakravarty, V. G. Paranjpe and S. Visvanathan "Possibilities of Desulphurizing Blast-Furnace Hot Metal" Part II: By Injecting Fluidized Agents, TISCO 4, (1957) pp. 80-88.
- Edward J. Dunn, Jr. "Rapid Desulfurization to 0.002 Percent Sulphur" Modern Casting, No. 6 (1961), pp. 90-95, AFS New Technology.
- E. J. Whittenberger, A. J. Deacon and L. C. Hymes, "Desulphurization of Basic Iron with Calcium Carbide" Blast Furnace and Steel Plant-Jun./Jul. 1956, pp. 644-689 and 747-754.
- S. L. Gertsman, "Desulfurization of Iron and Steel" Foundry, Aug. 1958, pp. 48-53.
- J. N. Hornak and E. J. Whittenberger "Desulphurization of Molten Iron" Proc. Blast. Furn. Coke Ovens Raw Materials Comm. AIME vol. 15, (1956) pp. 125-137. No. 23.
- John A. DeHuff and R. Schneidewind "Calcium Carbide Desulfurization by the Injection Process" Trans. Amer. Foundrym. Soc. 63 (1955) No. 22, pp. 524-532.
- R. B. Coates and J. V. Harding "The Batch Desulphurization of Molten Iron by the Calcium Carbide Injection Process" BCIRA-J. 8 (1960) No. 13, pp. 89-111, (Report No. 530).
- Harvey E. Henderson and Philip M. Hulme "Calcium Carbide Injection . . . Is New Tool in Gray Iron Metallurgy" Foundry, Apr. 1953, pp. 86-91 and 211-217.
- L. Marples and J. Pears, "Desulphurization of Basic Electric Arc Furnace Steel by the Injection of Powdered Materials" Journal of the Iron and Steel Institute, Jun. 1960, pp. 195-201.
- "Stainless Steel Making Calcium Carbide Injection Used for Sulphur Removal" Iron and Coal, Sep. 1, 1961, pp. 461-462.
- S. Santen and B. Ohman "Techniques for Obtaining Extremely Low Contents of Sulphur in Steel under Oxidizing and Reducing Conditions" Swedish Academy of Engineering Science Stockholm 1971, Report, 196-1, pp. 7-19.
- R. B. Coates and H. J. Leyshon, "A Porous Plug for Ladle Desulphurization and Carburization of Iron", Report 745, British Cast Iron Research J. 12, Jul. (1964) pp. 479-494.
- R. B. Coates, and H. J. Leyshon, "Desulphurization of Cast Iron" Report 747, British Cast Iron Research J. 12, Jul. 1964, pp. 507-518.
- K. Knaggs, M. Sewell and J. Turton; "The Production of Steel of Low Sulphur Content" Journal of the Iron and Steel Institute, Jan. 1962, pp. 4-18.
- J. N. Hornak and E. J. Whittenberger "The Desulfurization of Molten Iron" Journal of Metals, Apr. 1956, pp. 425-429.
- Von P. Flament and A. Hamilius, "Large Scale Desulphurization Tests with CaD 7525 Metallurgy for the Production of LD Melts with Low Sulphur Contents" Radex-Rundschau, Issue 1, 1972, pp. 27-34.
- Von Wilhelm vor dem Esche, Manfred Haucke, Hermann-Josef Kopineck, Wilhelm Wolf and Helmut Wysocki "Entschwefeln Von Roheisen Mit Feinkalk Ausserhalt des Hockofens" Stahl and Eisen 83, No. 29, No. 5, Feb. 28, 1963, pp. 270-281 with certified English Translation.
- "Weiterentwicklung auf dem Gebiet der Entschwefelung Von Robeisen" Stahl and Eisen 78, No. 13, Jun. 26, 1958, pp. 910-913 together with Certified English Translation thereof.

Von Herbert Pohl and Walter Maschlanka "Die Entschwefelung des Roheisens Nach dem Tauchlanzen-Verfahren" *Stahl und Eisen* 87, Feb. 23, 1967, No. 4, pp. 190-195 together with Certified English translation.

C. E. Wood, E. P. Barrett and W. Holbrook *Metals Technology*, vol. 5, No. 8, Dec. 1938, pp. 1-15.

Bernard Trentini et al "IRSID'S Powder Blowing Techniques Applied to Electric Steelmaking", *Proceed-*

ings of Electric Furnace Conference, 1963, pp. 28-42.

B. Trentini, P. Vayssiere, A. De Lavareille & J. Raguin "Powder-Blowing Techniques for Electric Steelmaking" *Journal of Metals*, Nov. 1964, pp. 885-890.

Walter Eichholz and Gerhard Behrendt "Entschwefelung von Thomasroheisen" *Stahl und Eisen*, issue 31, Aug. 1, 1940, published by Verein Deutscher Eisenhüttenleute, pp. 677-684.

Stahl und Eisen, No. 4, Feb. 4, 1971, pp. 152-154; No. 3.

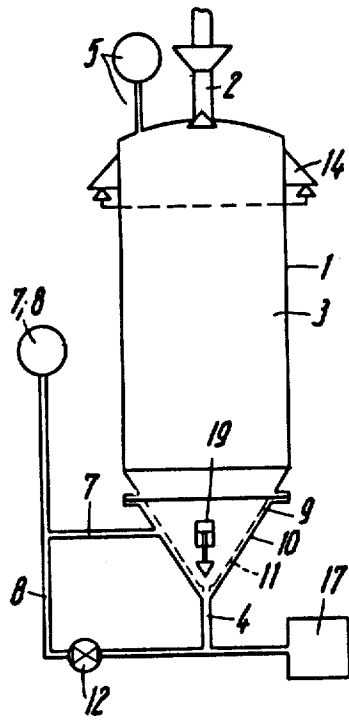

Fig. 1

Fig. 2

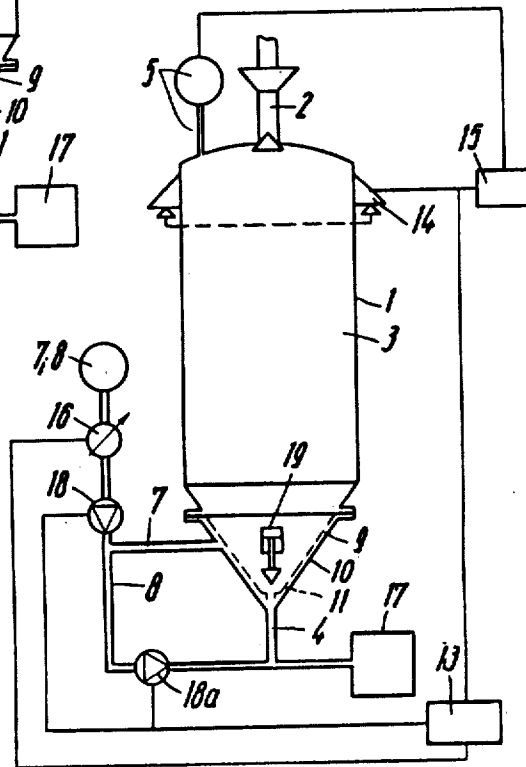
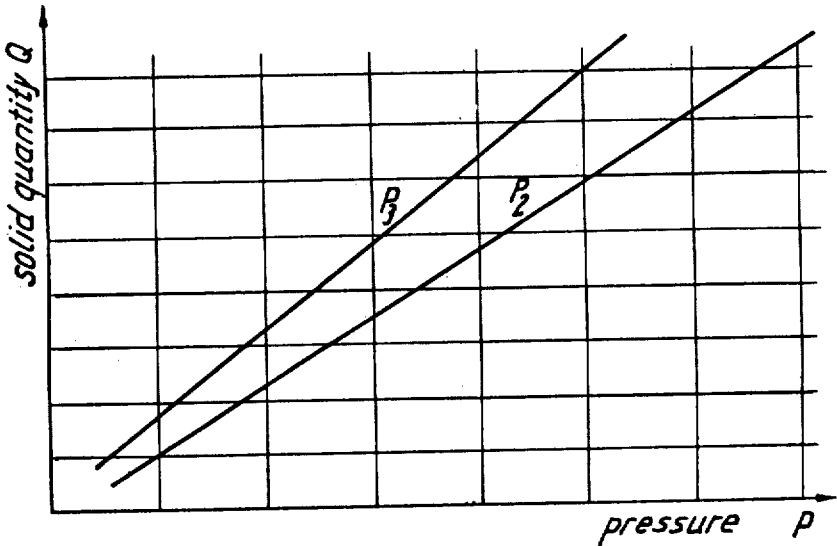

Fig. 3



METHOD AND APPARATUS FOR DISPENSING A FLUIDIZABLE SOLID FROM A PRESSURE VESSEL

Matter enclosed in heavy brackets [] appears in the original patent but forms no part of this reissue specification; matter printed in italics indicates the additions made by reissue.

BACKGROUND OF THE INVENTION

1. Field of the Invention

The invention relates to a method of dispensing a fluidizable solid from a pressure vessel having a weighing device and closable supply and discharge, wherein of three gas flows which are supplied to the solid and are at various pressure values P_1 , P_2 , P_3 , the gas flow at medium pressure P_2 is conducted into the vessel above the solid and the gas flow at relatively high pressure P_1 is conducted into the lower vessel region for fluidizing the solid, and the gas flow or relatively low pressure P_3 is conducted into the discharge connected thereto, the latter opening into a chamber at very low pressure P_4 , and the quantity of solid taken from the vessel being weighed and also to an apparatus for carrying out the method.

2. Discussion of the Prior Art

Some method steps and the apparatus required for these in the method described hereinbefore are known from publications: German Auslegeschrift No. 1,140,863, German Pat. No. 1,147,756 and German Auslegeschrift No. 1,148,938.

Further developments on the basis of these have led to a known procedure and an apparatus such as is illustrated in FIG. 1 and FIG. 3 of the accompanying drawings and will be described in detail hereinafter.

In FIG. 1, the apparatus includes a pressure vessel 1 having a closable charging aperture 2 through which solid 3 is introduced and a closable discharge 4, 19. Conduits 5, 7 and 8 are connected to gas pressure sources and a pressure reducing valve 12 is provided. The gas pressure conduit 7 leads into a chamber 9 formed between the vessel bottom end 10 and a second bottom end 11 which is arranged above bottom 10 and which is gas-pervious. A weighing device 14 for the solid 3 is connected to the vessel 1. There is a dispensing or consumption chamber 17 in which a very low pressure P_4 prevails.

The known apparatus illustrated operates as follows:

With the discharge 4 closed, the pressure vessel 1 is filled with a solid 3 in powder form. The charging aperture 2 is closed and the gas pressure sources 5, 7, 8 are connected, the gas pressure source 5 being used for regulating the top pressure P_2 the gas pressure source 7 for fluidizing the solid at pressure P_1 and the gas pressure source 8 for supplying the "conveying gas" at pressure P_3 . The gas supplied to the chamber 17 and providing pressure P_4 is the gas from the pressure source through 7 and the gas from the pressure source through 8. The prerequisite for conveying the fluidized solid is that the pressure relationship should be $P_1 > P_2 > P_3 > P_4$, P_1 being the pressure of the second gas pressure source through 7, P_2 the pressure of the first gas pressure source through 5, P_3 the pressure of the third gas pressure source through 8 and P_4 the pressure in the chamber 17. By means of the weighing apparatus 14 the quantity of solid to be dispensed from the vessel is determined. The known method is based on the

relationship shown in FIG. 3, according to which the conveyed quantity of solid [O] Q (e.g., in kg/min) depends on the pressure difference $P_2 - P_3$: $Q = \text{const.} (P_2 - P_3)$.

If the weighing apparatus 14 indicates for example that insufficient solid 3 is being conveyed, the top pressure P_2 is increased above the solid 3 in the vessel 1. As FIG. 3 shows more particularly, with rising top pressure P_2 , plotted on the abscissa, the conveyed quantity of solid Q plotted on the ordinate is increased. Owing to the increased quantity of solid Q per volume unit conveyed, however, the pressure P_3 of the conveying gas is also increased, but to a lesser extent than the top pressure P_2 . Consequently, with increasing top pressure P_2 the difference between top pressure P_2 and conveying pressure P_3 increases, this being therefore in direct relationship to the throughflow of the quantity of solid. This relationship is usually used for controlling the throughflow of the solid concerned.

To reduce the conveyed solid quantity Q the top pressure P_2 is reduced in accordance with the procedure described. A device for discharging gas can be provided additionally at the upper end of the vessel.

The control described does not influence the gas flow at relatively high pressure and the gas flow at relatively low pressure P_2 , P_3 , which exclusively determine the gas quantity and therefore the relation of gas to solid. The pressure reducing valve 12 which is associated with the third gas pressure through 8 and which operates like a proportional controller without a servo force, also discharges varying gas quantities if the pressure P_4 in the chamber 17 of lowest pressure fluctuates. This would be the case for example when moving an immersion lance into a molten metal bath. The pressure reducing valve 12 provided has the result, when this pressure change occurs, of producing the conveyance of a smaller quantity of gas. On the other hand the pressure reducing valve 12 when the pressure P_4 falls operates in such a manner that an increased quantity of gas is conveyed, in order thus to re-establish constant pressure conditions.

This has the result that for example when moving an immersion lance into and out of a torpedo ladle, with high throughflow quantities, liquid metal is thrown out of the ladle. To avoid this it is necessary to limit the degree to which the torpedo ladle is filled, thus reducing the working capacity.

In the constructional form described in FIG. 1 there also occurred when there was a considerable pressure drop in the chamber 17 of the very low pressure P_4 , blockages in the region of the chamber 9 since the opening of the pressure reducing valve 12 which results caused a corresponding pressure drop of P_1 in the chamber 9 and the pressure P_1 became too small in relation to the pressure P_2 . The results of this are inadequate fluidization of the solid and non-uniform dispensing.

SUMMARY OF THE INVENTION

Broadly, this invention contemplates an improvement in a process for dispensing a fluidizable solid from the lower portion of a pressure vessel having a weighing device, a closable supply, a discharge, a source of three gas flows, one of which is applied within the vessel at a level above the solid to be fluidized at a pressure P_2 , a second of which is applied within said vessel in the lower portion of said vessel at a pressure P_1 , a third of which is applied within the discharge orifice at a pres-

sure P_3 , said discharge orifice terminating in a chamber maintained under a pressure P_4 , the improvement which comprises determining the amount of solid dispensed at said weighing device, determining the throughflow quantity of gas flow, said throughflow quantity of gas flow being the sum of the amount of gas at P_1 and P_3 , and regulating the amount of gas and amount of solid to maintain a predetermined constant gas/solid dispensed ratio under conditions such that $P_1 > P_2 > P_3 > P_4$.

In a particularly desirable embodiment, this invention contemplates an improvement in an apparatus for dispensing a fluidizable solid from the lower portion of a pressure vessel having a weighing device, a closable supply, a discharge, a source of three gas flows, a first of which terminates within the vessel at a level above the solid to be dispensed in an upper portion thereof, a second of which terminates within the vessel in a lower portion thereof, a third of which terminates in said discharge, said discharge connected to a chamber, the improvement comprising means in association with said weighing device to determine the amount of a solid dispensed into said vessel, means for determining the sum of gas throughput of the gases from the second and third gas source, and regulating means for regulating the gas and solid to maintain a constant gas/solid ratio.

The apparatus of the present invention is particularly useful in carrying out a process wherein calcium carbide is fed through immersion lances into a pig iron desulphurization process whereby the amount of calcium carbide throughflow can be regulated to a desired high value in the range of 40 to 250 kg/min. while maintaining a constant ratio of gas to solid dispensed in the range of 2 to 20 NI/kg. The present invention increases the efficiency of the pressure vessel and the solid fluidization process. It eliminates pressure fluctuations which in turn can affect the amount of solid fluidized into a subsequent process which can introduce less than optimum uniformity in the second process with respect to the process conditions and the products obtained. Additionally, excess quantities of gas emanating from the pressure vessel are eliminated such that only the amount of gas needed for the fluidization need be employed.

The present invention has as its object to improve the conditions obtaining with the above-described method.

According to the invention the throughflow quantity of solid and also the throughflow quantity of the gas flow, being that at relatively high and relatively low pressure (P_1 and P_3), are regulated in accordance with a predetermined constant gas/solid ratio so as to maintain that ratio during operation.

Preferably, the control of the throughflow quantity of the solid is effected by means of a pressure variation of the gas flow at medium pressure, P_2 .

It is of particular advantage to control the throughflow quantity of the gas flow (P_1 and P_3) by reference to the throughflow quantity of solid.

Preferably, to control the throughflow quantities of the gas flow only the gas flow of relatively low pressure, P_3 , is regulated.

The method according to the invention is particularly suitable in applications where solids in powder form are introduced into molten metal. It is more particularly suitable for the desulphurization of pig iron by means of an immersion lance, the solid throughflow (e.g., of calcium carbide) being regulated to a desired value of

40-250 kg/min, preferably 100-140 kg/min, and the gas/solid ratio to 2-20 NI/Kg, preferably 4-10 NI/kg.

To carry out the method according to the invention a particularly suitable apparatus includes a pressure vessel having a weighing apparatus, a closable charging aperture for the solid in the upper region, and in the lower region a closable discharge, a first regulatable gas pressure source connected to the upper vessel region to provide gas flow at medium pressure P_2 , a third regulatable gas pressure supply connected to the discharge to provide the gas flow at relatively low pressure P_3 , and a second gas pressure supply connected to the lower vessel region for the gas flow at relatively high pressure P_1 , the second gas pressure supply opening into a chamber between the vessel bottom end and a gas-pervious second bottom end arranged thereabove, and respective control devices being provided one for the gas throughflow quantity, being that from the second and third gas pressure supplies, and the other for the quantity of solid dispensed.

In a preferred constructional form, the control device for the gas throughflow quantity acts on a valve of the third gas pressure supply. The gas throughflow quantity of the second and third gas pressure supplies is ascertained with a meter.

In a further preferred constructional form, the control device for dispensing solid material receives from the weighing apparatus an actual value for the solid quantity dispensed and regulates the pressure P_2 from the first gas pressure source in accordance with the deviation between actual and desired values.

BRIEF DESCRIPTION OF DRAWINGS

Referring again to the attached drawings:

FIG. 1 is a cross sectional diagrammatic view of an apparatus according to the prior art whose operation is described above;

FIG. 2 is a cross sectional diagrammatic view of the elevation of the apparatus of the present invention employed to carry out the claimed process; and

FIG. 3 is a graph showing the amount of conveyed material against pressure.

DESCRIPTION OF SPECIFIC EMBODIMENTS

It is particularly suitable to use a device wherein the actual value of the solid quantity dispensed is used for the control device for the gas throughflow quantity of the second and third gas pressure sources as a desired value. One embodiment of the invention is shown diagrammatically in FIG. 2 of the accompanying drawing and will be described in detail hereinafter.

Like the known apparatus previously described, this apparatus includes a pressure vessel 1 with a closable charging aperture 2 and a discharge 4 closable by a plug 19 for the solid 3. For fluidization, the double-walled bottom end is composed of the vessel bottom end 10, the second gas-pervious bottom end 11 and the chamber 9 situated therebetween. Opening from above into the pressure vessel 1 is a first gas pressure supply 5 under a pressure P_2 , into the chamber 9 opens the second gas pressure supply 7 at pressure P_1 and into the discharge 4 the third gas pressure supply 8 at the pressure P_3 . From the discharge 4, a conduit leads to a chamber 17 which is at very low pressure P_4 . Here also conveyance requires that $P_1 > P_2 > P_3 > P_4$. The weighing device 14 is also provided for metering the quantity of solid dispensed at the pressure vessel 1.

A control device 15 is associated with the weighing device 14 which compares the actual value given by the weighing device with a desired value and in accordance with the result regulates the pressure P_2 of the first gas pressure supply. There is also provided in the conduits leading from the second and third gas pressure sources 7, 8 to the chamber 9 and the discharge 4 a meter 16 for metering the gas throughflow quantity (being the gas at P_1 plus that at P_3) and also, connected thereto, a regulatable valve 18 or 18a. To regulate the gas throughflow quantity of the second and third gas pressure supplies from sources 7, 8 there is provided a further control device 13 which receives the actual value of the dispensed quantity of solid from weighing device 14 and sets up this value, taking into account a preset desired constant gas/solid ratio, as the appropriate desired value for the gas throughflow quantity. Thus the control devices 13, 15 regulate the throughflow quantities of solid and gas to maintain the preset constant ratio.

In a particular example of the desulphurisation of pig iron with the immersion lance process the method of operation would be as follows:

Assume that the desired gas/solid ratio (Air/Calcium Carbide) is to amount to 5 NI/kg. At the beginning of treatment the immersion depth of the lance is estimated and for example a pressure P_2 is set by means of the first gas pressure source 5 in accordance with FIG. 3 to a value which corresponds approximately to the desired value of the solid flow. Likewise an initial position is selected for the valves 18 or 18a in the supply conduits of the second and third gas pressure supplies, so that the desired ratio of air to calcium carbide is approximately reached. Then the immersion lance is moved in and the treatment of the pig iron begun. The quantity of solid dispensed per unit of time is examined by the control device 15. If the actual value does not correspond to the [present] preset desired value, the pressure P_2 is adjusted. Also the actual value of the quantity of solid dispensed is continuously monitored by means of the control device 13 and taking the predetermined gas/solid ratio into account is converted into the desired value for the regulation of the air quantity.

According to above-described method within the invention uniform delivery of solid is achieved since the control of the volumes of solid and gas, taking normal conditions into account for the gas, avoids the use and any disadvantageous operation of the pressure reducing valve 12 which was described initially. The known pressure reducing valve 12 operating as a proportional controller without servo force is not necessary in the apparatus within the invention. However, to maintain desired pressure conditions a manually adjustable pressure reducing valve can be arranged at the valve 18 (in desulphurisation, e.g., $1\frac{1}{2}$ to 2 atmospheres excess pressure) between the gas pressure source 7, 8 and the valve 18, 18a.

A further advantage is that pressure fluctuations in the chamber 17 do not cause any sudden changes in the gas delivery quantity, whereby pulsating conveyance is obviated. Furthermore there are no longer the excessive gas quantities delivered when the immersion lance is put in and taken out, which led to the throwing-out of molten metal initially described. Blockages owing to inadequate fluidisation no longer occur. It is of particular practical importance that the gas-solid ratio remains constant, which is of significance more particularly when using the invention in the field of metallurgy. For example, it has been found possible by the above

method to increase to 95 percent the capacity of torpedo ladles, which was limited to 80 percent with the previously described known methods.

It should be stressed that the use of the above method within the invention has been found to be advantageous also for the introduction of other fine-grain or powder-form solids into molten metal baths, e.g., for the introduction of silicon or aluminium into iron melts.

It is to be understood that the apparatus of the present invention is characterized by a first source of gas flow disposed in an upper region of the pressure vessel, i.e., terminating in the upper region or portion of the pressure vessel. By the term "upper region or portion" is meant the upper half of the vessel, similarly with respect to the second source of gas located in the lower portion of the vessel, it should be understood that the term "lower portion" refers to the bottom half of the vessel. Preferably, this latter second source of gas is disposed in an inverted conically shaped at the bottom of the vessel and terminates in a confined region defined by an inside wall of the inverted conically shaped zone and a liner disposed thereover which is gas-pervious. Preferably, the first gas source is disposed at the top of the vessel, and in any event, above the means for supplying solid to the vessel.

What is claimed is:

1. In a process for dispensing fluidizable solid from the lower portion of a pressure vessel having a weighing device at which said solid is dispensed, a closable supply, a discharge, a source of three gas flows, one of which is applied within the vessel at a level above the solid to be fluidized at a pressure P_2 , a second of which is applied within said vessel in the lower portion of said vessel at a pressure P_1 , a third of which is applied within the discharge orifice at a pressure P_3 , said discharge orifice terminating in a chamber maintained under a pressure P_4 , the improvement which comprises determining the amount of solid dispensed at said weighing device, determining the throughflow quantity of gas flow, said throughflow quantity of gas flow being the sum of the amount of gas having a pressure P_1 and the amount of gas having a pressure P_3 and regulating the amount of gas and amount of solid to maintain a predetermined constant gas/solid dispensed ratio under conditions such that $P_1 > P_2 > P_3 > P_4$.

2. An improvement according to claim 1 wherein the ratio of gas to solid dispensed is regulated by varying the pressure of the gas at pressure P_2 .

3. An improvement according to claim 2 wherein the throughflow quantity of gas is controlled in response to the throughflow quantity of solid determined to have been dispensed at said weighing device.

4. A method according to claim 1 wherein the throughflow quantity of the gas flow is controlled by varying only the gas flow at pressure P_3 and maintaining the gas at pressure P_1 at constant pressure.

5. A method according to claim 1, wherein the solid is in powder form and is dispensed into a metal melt.

6. A method according to claim 5, wherein a desulfurizing agent is fluidized and dispensed from said vessel at a rate between 40 and 250 kg/min, the gas/solid ratio is maintained at a value in the range from 2 to 20 NI/kg and said agent is directed into a pig iron desulphurization process through an immersion lance.

7. A method according to claim 6 wherein the desulfurizing agent is calcium carbide.

8. A method according to claim 6 wherein the solid throughflow rate is between 100 and 140 kg/min and the gas/solid ratio is between 4 and 10 NI/kg.

9. In an apparatus for dispensing a fluidizable solid from the lower portion of a pressure vessel having a weighing device, a closable supply, a discharge, a source of three gas flows, a first of which terminates within the vessel at a level above the solid in an upper portion thereof, a second of which terminates within the vessel in a lower portion thereof, a third of which terminates in said discharge, said discharge connected to a chamber, the improvement which comprises means in association with said weighing device to determine the amount of a solid dispensed into said vessel, means for determining the amount of gas throughput of the gases from second and third gas sources, and regulating means for regulating the gas and solid to maintain a constant gas/solid ratio.

10. An improvement according to claim 9 wherein said regulating means is in operative association with a flow controlling means on the third gas source.

11. An improvement according to claim 9 wherein means are provided in association with the first gas source to regulate the pressure thereof, said means responsive to an actual value measured by weighing device for solid dispensed.

12. An improvement according to claim 7 wherein a control device is provided to regulate the quantity of the gas throughflow which device is responsive to the actual value of quantity of solid dispensed.

13. In a device for dispensing a fluidizable solid from a pressure vessel having a weighing device, said vessel having in its upper portion a closable feed aperture and a gas line having a first controllable gas pressure source of pressure P_2 , said vessel having in the lower portion thereof a loosening bottom and a closable discharge opening, said discharge opening having a discharge line, said discharge line discharging into a chamber of pressure P_4 , said vessel having in the loosening bottom and in, the discharge line a second and third line discharge having a second controllable gas pressure source for a gas stream of pressure P_1 and a third controllable gas pressure source at pressure P_3 , the improvement to maintain a gas quantity/solid quantity ratio constant which comprises a first regulating means for the solid quantity which first regulating means is operable to compare the actual value of the solid quantity measured by means of the weighing device which has a preset desired value, which first regulating means is operable to adjust the pressure of the gas stream of pressure P_2 by means of said first controllable gas pressure source by synchronous adjustment thereof, a second regulating means for the gas quantity of the respective gas streams of pressures P_1 and P_3 , which second regulating means receives the actual value of the gas quantity and the actual value of the solid quantity measured by the weighing device and, in the event of deviation from the gas quantity/solid quantity ratio to be maintained constant, adjusts the quantity by means of said second controllable gas pressure source to a constant preselected value, said device having magnitudes of pressures such that the following relationship is maintained: $P_1 > P_2 > P_3 > P_4$.

14. A device according to claim 13 wherein said second regulating means is responsive to a measuring device arranged following the second controllable gas pressure source and adjusts the gas quantity of gas at

pressures P_1 and P_3 , respectively, through control valves.

15. A device according to claim 13 wherein said second regulating means adjusts only the gas quantity of the gas stream at pressure P_3 by means of a control valve.

16. A process according to claim 1 wherein said fluidizable solid is passed downwardly vertically from said pressure vessel into said line containing said discharge orifice and containing gas at a pressure P_3 .

17. A process according to claim 16 wherein said molten metal is disposed in a torpedo ladle.

18. A process according to claim 2 wherein said fluidizable solid is passed downwardly vertically from said pressure vessel into said line containing said discharge orifice and containing gas at pressure P_3 .

19. A process according to claim 18 wherein said molten metal is disposed in a torpedo ladle.

20. A process according to claim 4 wherein said fluidizable solid is passed downwardly vertically from said pressure vessel into said line containing said discharge orifice and containing gas at a pressure P_3 .

21. A process according to claim 20 wherein said molten metal is disposed in a torpedo ladle.

22. A process according to claim 5 wherein said fluidizable solid is passed downwardly vertically from said pressure vessel into said line containing said discharge orifice and containing gas at a pressure P_3 .

23. A process according to claim 22 wherein said molten metal is disposed in a torpedo ladle.

24. A process according to claim 5 wherein said molten metal is disposed in a torpedo ladle.

25. A process according to claim 5 wherein said gas/solid ratio is maintained at a value in the range from 2 to 20 NI/kg.

26. A process according to claim 5 wherein said powder is a desulfurizing agent.

27. A process according to claim 5 wherein said solid comprises silicon.

28. A process according to claim 5 wherein said solid comprises aluminum.

29. A process according to claim 6 wherein said fluidizable solid is passed downwardly vertically from said pressure vessel into said line containing said discharge orifice and containing gas at a pressure P_3 .

30. A process according to claim 29 wherein said molten metal is disposed in a torpedo ladle.

31. An apparatus according to claim 12 wherein said discharge is disposed vertically below said closable supply.

32. An apparatus according to claim 9 wherein said discharge is disposed vertically below said closable supply.

33. An apparatus according to claim 11 wherein said discharge is disposed vertically below said closable supply.

34. A device according to claim 13 wherein said discharge line is disposed vertically below said discharge opening.

35. In a process for dispensing via an immersion lance immersed into a metal melt fluidizable solid from the lower portion of a pressure vessel having a weighing device at which said solid is dispensed, a closable supply, a discharge, a source of three gas flows, one of which is applied within the vessel at a level above the solid to be fluidized at a pressure P_2 , a second of which is applied within said vessel in the lower portion of said vessel at a pressure P_1 , a third of which is applied within the discharge orifice at a pressure P_3 , said discharge orifice terminating via said immersed lance in said metal melt at a pressure P_4 , the improvement which comprises determining the amount of solid dispensed

at said weighing device, determining the throughflow quantity of gas flow, said throughflow quantity of gas flow being the sum of the amount of gas at a pressure having a pressure P_1 and the amount of gas having a pressure P_3 and regulating the amount of gas and amount of solid to maintain a predetermined constant gas/solid dispensed ratio under conditions such that $P_1 > P_2 > P_3 > P_4$.

36. A process according to claim 35 wherein said fluidizable solid is passed downwardly vertically from said pressure vessel into said line containing said discharge orifice and containing gas at a pressure P_3 .

37. A process according to claim 36 wherein said metal melt is disposed in a torpedo ladle.

38. A process according to claim 35 wherein said metal melt is disposed in a torpedo ladle.

39. A process according to claim 35 wherein the ratio of gas to solid dispensed is regulated by varying the pressure of the gas at pressure P_2 .

40. A process according to claim 39 wherein said metal melt is disposed in a torpedo ladle.

41. A process according to claim 39 wherein the throughflow quantity of gas is controlled in response to the throughflow quantity of solid determined to have been dispensed at said weighing device.

42. A process according to claim 41 wherein said metal melt is disposed in a torpedo ladle.

43. A process according to claim 41 wherein said fluidizable solid is passed downwardly vertically from said pressure vessel into said line containing said discharge orifice and containing gas at a pressure P_3 .

44. A process according to claim 43 wherein said metal melt is disposed in a torpedo ladle.

45. A process according to claim 39 wherein said fluidizable solid is passed downwardly vertically from said pressure vessel into said line containing said discharge orifice and containing gas at a pressure P_3 .

46. A process according to claim 45 wherein said metal melt is disposed in a torpedo ladle.

47. A process according to claim 35 wherein the throughflow quantity of gas flow is controlled by varying only the gas flow at pressure P_3 and maintaining the gas at pressure P_1 at constant pressure.

48. A process according to claim 47 wherein said metal melt is disposed in a torpedo ladle.

49. A process according to claim 47 wherein said fluidizable solid is passed downwardly vertically from said pressure vessel into said line containing said discharge orifice and containing gas at a pressure P_3 .

50. A process according to claim 49 wherein said metal melt is disposed in a torpedo ladle.

51. A process according to claim 35 wherein the solid is in powder form.

52. A process according to claim 51 wherein said solid is a desulfurizing agent.

53. A process according to claim 51 wherein said solid comprises silicon.

54. A process according to claim 51 wherein said solid comprises aluminum.

55. A process according to claim 51 wherein a desulfurizing agent is fluidized and dispensed from said vessel at a rate between 40 and 250 kg/min, the gas/solid ratio is maintained at a value in the range from 2 to 20 NI/kg and said agent is directed into a pig iron desulfurization process through said immersion lance.

56. A method according to claim 55 wherein the solid throughflow rate is between 100 and 140 kg/min and the gas/solid ratio is between 4 and 10 NI/kg.

57. A process according to claim 55 wherein said metal melt is disposed in a torpedo ladle.

58. A method according to claim 55 wherein the desulfurization agent is calcium carbide.

59. A process according to claim 58 wherein said desulfurizing agent is calcium carbide.

60. A process according to claim 55 wherein said fluidizable solid is passed downwardly vertically from said pressure vessel into said line containing said discharge orifice and containing gas at a pressure P_3 .

61. A process according to claim 60 wherein said metal melt is disposed in a torpedo ladle.

62. A process according to claim 51 wherein said gas/solid ratio is maintained at a value in the range from 2 to 20 NI/kg.

63. A process according to claim 62 wherein said powder is fluidized and dispensed from said vessel at a rate between 40 and 250 kg/min.

64. In an apparatus for dispensing a fluidizable solid via an immersion lance, into a metal melt into which said lance is immersed, from the lower portion of a pressure vessel having a weighing device, a closable supply, a discharge, a source of three gas flows, a first of which terminates within the vessel at a level above the solid in an upper portion thereof, a second of which terminates within the vessel in a lower portion thereof, a third of which terminates in a discharge line, said discharge line discharging into a metal melt via an immersion lance immersed in said metal melt, the improvement which comprises means in association with said weighing device to determine the amount of a solid dispensed into said metal melt, means for determining the amount of gas throughput of the gases from second and third sources, and regulating means for regulating the gas and solid to maintain a constant gas/solid ratio.

65. An apparatus according to claim 64 wherein said metal melt is disposed in a torpedo ladle.

66. An apparatus according to claim 64 wherein said discharge is disposed vertically below said closable supply.

67. An apparatus according to claim 66 wherein said metal melt is disposed in a torpedo ladle.

68. An apparatus according to claim 64 wherein said regulating means is in operative association with a flow controlling means on the third gas source.

69. An apparatus according to claim 68 wherein said metal melt is disposed in a torpedo ladle.

70. An apparatus according to claim 68 wherein said discharge is disposed vertically below said closable supply.

71. An apparatus according to claim 70 wherein said metal melt is disposed in a torpedo ladle.

72. An apparatus according to claim 64 wherein means are provided in associated with the first gas source to regulate the pressure thereof, said means responsive to an actual value measured by weighing device for solid dispensed.

73. An apparatus according to claim 72 wherein said metal melt is disposed in a torpedo ladle.

74. An apparatus according to claim 72 wherein said discharge is disposed vertically below said closable supply.

75. An apparatus according to claim 74 wherein said metal melt is disposed in a torpedo ladle.

76. An apparatus according to claim 64 wherein a control device is provided to regulate the quantity of the gas throughflow which device is responsive to the actual value of the quantity of solid dispensed.

77. An apparatus according to claim 76 wherein said metal melt is disposed in a torpedo ladle.

78. An apparatus according to claim 76 wherein said discharge is disposed vertically below said closable supply.

79. A process according to claim 78 wherein said powder is fluidized and dispensed from said vessel at a rate between 40 and 250 kg/min.

80. An apparatus according to claim 78 wherein said metal melt is disposed in a torpedo ladle.

81. In a device for dispensing a fluidizable solid via an immersion lance into a metal melt into which said lance is immersed from a pressure vessel having a weighing device, said vessel having in its upper portion a closable feed aperture and a gas line having a first controllable gas pressure source of pressure P_2 , said vessel having in the lower portion thereof a loosening bottom and a closable discharge opening, said discharge opening having a discharge line, said discharge line discharging into a metal melt of pressure P_4 via an immersion lance immersed into said metal melt, said vessel having in the loosening bottom and in the discharge line a second and third line discharge having a second controllable gas pressure source for a gas stream of pressure P_1 and a third controllable gas pressure source at pressure P_3 , the improvement to maintain a gas quantity/solid quantity ratio constant which comprises a first regulating means for the solid quantity which first regulating means is operable to compare the actual value of the solid quantity measured by means of the weighing device which has a preset desired value, which first regulating means is operable to adjust the pressure of the gas stream of pressure P_2 by means of said first controllable gas pressure source by synchronous adjustment thereof, a second regulating means for the gas quantity of the respective gas streams of pressures P_1 and P_3 , which second regulating means re-

ceives the actual value of the gas quantity and the actual value of the solid quantity measured by the weighing device and, in the event of deviation from the gas quantity/solid quantity ratio to be maintained constant, adjusts the quantity by means of said second controllable gas pressure source to a constant preselected value, said device having magnitudes of pressure such that the following relationship is maintained: $P_1 > P_2 > P_3 > P_4$.

82. A device according to claim 81 wherein said metal melt is disposed in a torpedo ladle.

83. A device according to claim 81 wherein said second regulating means is responsive to a measuring device arranged following the second controllable gas pressure source and adjusts the gas quantity of gas at pressures P_1 and P_3 , respectively, through control valves.

84. A device according to claim 83 wherein said metal melt is disposed in a torpedo ladle.

85. A device according to claim 81 wherein said second regulating means adjusts only the gas quantity of the gas stream at pressure P_3 by means of a control valve.

86. A device according to claim 85 wherein said metal melt is disposed in a torpedo ladle.

87. A device according to claim 81 wherein said discharge line is disposed vertically below said discharge opening.

88. A device according to claim 87 wherein said metal melt is disposed in a torpedo ladle.

89. A process according to claim 87 wherein said desulfurizing agent is calcium carbide.

* * * * *

35

40

45

50

55

60

65