

(19) World Intellectual Property Organization
International Bureau



(43) International Publication Date
25 June 2009 (25.06.2009)

PCT

(10) International Publication Number
WO 2009/077200 A1

(51) International Patent Classification:
H03M 3/02 (2006.01) H03M 3/04 (2006.01)

(74) Agents: GRAY, Peter, John, Bracey et al.; Thompson Gray LLP, Central Court, 25 Southampton Buildings, London WC2A 1AL (GB).

(21) International Application Number:
PCT/EP2008/010879

(81) Designated States (unless otherwise indicated, for every kind of national protection available): AE, AG, AL, AM, AO, AT, AU, AZ, BA, BB, BG, BH, BR, BW, BY, BZ, CA, CH, CN, CO, CR, CU, CZ, DE, DK, DM, DO, DZ, EC, EE, EG, ES, FI, GB, GD, GE, GH, GM, GT, HN, HR, HU, ID, IL, IN, IS, JP, KE, KG, KM, KN, KP, KR, KZ, LA, LC, LK, LR, LS, LT, LU, LY, MA, MD, ME, MG, MK, MN, MW, MX, MY, MZ, NA, NG, NI, NO, NZ, OM, PG, PH, PL, PT, RO, RS, RU, SC, SD, SE, SG, SK, SL, SM, ST, SV, SY, TJ, TM, TN, TR, TT, TZ, UA, UG, US, UZ, VC, VN, ZA, ZM, ZW.

(22) International Filing Date:
16 December 2008 (16.12.2008)

(25) Filing Language: English

(26) Publication Language: English

(30) Priority Data:
07123562.6 19 December 2007 (19.12.2007) EP

(84) Designated States (unless otherwise indicated, for every kind of regional protection available): ARIPO (BW, GH, GM, KE, LS, MW, MZ, NA, SD, SL, SZ, TZ, UG, ZM, ZW), Eurasian (AM, AZ, BY, KG, KZ, MD, RU, TJ, TM), European (AT, BE, BG, CH, CY, CZ, DE, DK, EE, ES, FI, FR, GB, GR, HR, HU, IE, IS, IT, LT, LU, LV, MC, MT, NL, NO, PL, PT, RO, SE, SI, SK, TR), OAPI (BF, BJ, CF, CG, CI, CM, GA, GN, GQ, GW, ML, MR, NE, SN, TD, TG).

(71) Applicant (for all designated States except US):
ST WIRELESS SA [CH/CH]; 39 chemin du Champ-des-Filles, Plan-les-Ouates, CH-1228 Geneva (CH).

(72) Inventor; and

(75) Inventor/Applicant (for US only): VAN VELDHoven, Robert, Henrikus, Margaretha [NL/NL]; Denariehof 6, NL-5551 XM Dommelen (NL).

Published:
— with international search report

[Continued on next page]

(54) Title: A MULTI-BIT SIGMA-DELTA MODULATOR WITH REDUCED NUMBER OF BITS IN FEEDBACK PATH

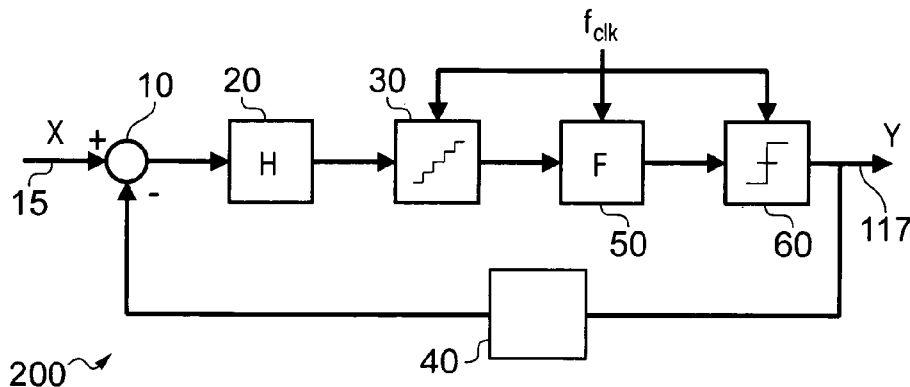

FIG. 8

(57) Abstract: A sigma-delta modulator (200) for an ADC, passes an input signal to a loop filter (20), then to a multi-bit quantiser (30) of the modulator (200). An output of the quantiser (30) is passed to a digital filter (50), and a feedback signal is passed back to the loop filter (20), the feedback signal having fewer bits than are produced by the multi-bit quantiser (30). No separate feedback loop for the digital filter (50) is used, so as to reduce the need to adjust the loop filter for stable operation. The digital filter (50) can have an order greater than one in the passband of the sigma-delta modulator (200).

WO 2009/077200 A1



-
- *before the expiration of the time limit for amending the claims and to be republished in the event of receipt of amendments*

A MULTI-BIT SIGMA-DELTA MODULATOR WITH REDUCED NUMBER OF BITS IN FEEDBACK PATH

FIELD OF THE INVENTION

5 This invention relates to sigma-delta modulators, to digital-to-analogue converters having a sigma-delta modulator, and to methods of converting a signal.

BACKGROUND TO THE INVENTION

10 Sigma-delta ($\Sigma\Delta$) modulators are employed in analogue-to-digital converters (ADCs). US6404368 discloses in Figure 3 and its accompanying text a $\Sigma\Delta$ modulator to be used in an over-sampling type ADC, which includes an analogue $\Sigma\Delta$ modulator coupled to a digital $\Sigma\Delta$ modulator. The analogue $\Sigma\Delta$ modulator includes a digital-to-analogue converter (DAC) which converts a one-bit feed-back signal to an analogue signal, an analogue adder or subtractor which calculates a difference between an output signal
15 transmitted from the DAC and an analogue input signal. The analogue $\Sigma\Delta$ modulator also has an analogue integrator, which integrates output signals transmitted from the analogue adder or subtractor, and a first quantiser which converts an output signal transmitted from the analogue integrator, into a digital signal. The digital $\Sigma\Delta$ modulator includes a digital adder or subtractor which calculates a difference between an output signal transmitted
20 from the first quantiser and the one-bit feed-back signal, a digital integrator which integrates output signals transmitted from the digital adder or subtractor, a second quantiser which converts an output signal transmitted from the digital integrator into a one-bit digital signal, and a delay element which delays the one-bit digital signal transmitted from the second quantiser and feeds the thus delayed signal back as the one-bit feed-
25 back signal. Since the feedback signal transmitted to the analogue modulator is a one-bit signal, distortion caused by non-linearity error of the DAC can be reduced.

DISCLOSURE OF INVENTION

30 According to a first aspect of the disclosure there is provided a sigma-delta modulator comprising:

- a summing stage for generating an error signal as the difference between an input signal and a feedback signal;
- a loop filter coupled to an output of the summing stage for filtering the error signal;
- 35 - a multi-bit quantiser coupled to an output of the loop filter for quantising the filtered error signal;

- a digital filter coupled to an output of the multi-bit quantiser; and
- a feedback path coupling an output of the digital filter to the summing stage for providing the feedback signal to the summing stage,

5 wherein the feedback signal has fewer bits than a number of bits produced by the multi-bit quantiser and there is no other feedback path coupling the output of the digital filter to an input of the digital filter.

According to a second aspect of the disclosure there is provided a method of converting a signal comprising:

- generating an error signal as the difference between an input signal and a

10 feedback signal;

- filtering the error signal;

- quantising the filtered error signal using a multi-bit quantiser;

- filtering the quantised and filtered error signal using a digital filter; and

- generating the feedback signal from an output signal of the digital filter;

15 wherein the feedback signal has fewer bits than a number of bits produced by the multi-bit quantiser and there is no other feedback of the output signal of the digital filter to an input of the digital filter.

The use of a multi-bit quantiser helps reduce quantisation noise and the feedback having fewer bits helps reduce non-linearity errors, which can arise in the feedback path.

20 The $\Sigma\Delta$ modulator of the prior art mentioned above has separate feedback loops for the analogue $\Sigma\Delta$ modulator and for the digital $\Sigma\Delta$ modulator. In contrast, the invention has no feedback path coupling the output of the digital filter to an input of the digital filter other than the feedback path coupling the output of the digital filter to the summing stage. In other words, the $\Sigma\Delta$ modulator of the invention may have only a single feedback path,

25 that feedback path being the feedback path coupling the output of the digital filter to the summing stage. This means that there is less or no need for a multiple loop stability analysis. It can therefore be easier to design or adjust the loop filter for stable operation of the $\Sigma\Delta$ modulator, whether the loop filter is arranged as a first order filter or as a higher order filter.

30 According to a third aspect of the disclosure there is provided a sigma-delta modulator comprising:

- a summing stage for generating an error signal as the difference between an input signal and a feedback signal;

- a loop filter coupled to an output of the summing stage for filtering the error

35 signal;

- a multi-bit quantiser coupled to an output of the loop filter for quantising the filtered error signal;

- a digital filter coupled to an output of the multi-bit quantiser; and

5 - a feedback path coupling an output of the digital filter to the summing stage for providing the feedback signal to the summing stage, the feedback signal having fewer bits than a number of bits produced by the multi-bit quantiser,

wherein the digital filter has an order greater than one in a passband of the sigma-delta modulator.

10 According to a fourth aspect of the disclosure there is provided a method of converting a signal comprising:

- generating an error signal as the difference between an input signal and a feedback signal;

- filtering the error signal;

- quantising the filtered error signal using a multi-bit quantiser;

15 - filtering the quantised and filtered error signal using a digital filter; and

- generating the feedback signal from an output signal of the digital filter,

wherein the feedback signal has fewer bits than a number of bits produced by the multi-bit quantiser; and

20 wherein the digital filter has an order greater than one inside a passband of the sigma-delta modulator.

By providing, after the multi-bit quantiser, a digital filter having an order greater than one, the digital filter can have a gain difference between inside and outside of the passband of the $\Sigma\Delta$ modulator sufficient to provide improved suppression of the quantisation noise in the feedback signal. Also, the remaining quantisation noise can be less correlated with the input signal. This means the remaining noise tends to be less concentrated in the frequencies predominating in the input signal, which means less distortion of the output at the frequencies of interest. This can be applied in a $\Sigma\Delta$ modulator, or in any feedback type modulator where there is a big noise source which can be suppressed by providing gain in front of it.

30 As in the first aspect, the use of a multi-bit quantiser helps reduce quantisation noise. The feedback having fewer bits helps reduce non-linearity errors.

An additional feature of some embodiments is the frequency response of the digital filter having a substantially flat gain profile outside of the passband of the sigma-delta modulator. A notable consequence of the flat gain is that there will be little or no effect on the characteristics of the loop filter. This means that there may be little or no need to alter a conventional loop filter to accommodate the digital filter and the feedback

signal having fewer bits. This can enable an increase in performance with little or no burden of redesigning and optimising the loop filter. This can otherwise be a considerable burden, for example in cases where there are multiple adjustments such as filter coefficients, and where it is time consuming to make adjustments without adding
5 instability, or for other reasons. Furthermore, in some cases, costs in redesign, manufacturing and retesting can be saved, or the design of the loop filter can be made simpler or more effective by providing the flat gain characteristic.

An additional feature of some embodiments is the difference in gain of the digital filter inside and outside of the passband of the sigma-delta modulator being greater than
10 or equal to $20\log_{10}((2^y-1)/(2^z-1))$ dB, where y is the number of bits of the feedback signal and z is the number of bits of the multi-bit quantiser. This can provide improved suppression of quantisation noise.

An additional feature of some embodiments is the frequency response of the combination of the loop filter and the digital filter having a first order roll-off of gain outside
15 of the passband of the sigma-delta modulator. This can provide stability of the sigma-delta modulator loop.

Any of the additional features can be combined together and combined with any of the aspects. Other advantages will be apparent to those skilled in the art, especially over other prior art. Numerous variations and modifications can be made without departing
20 from the claims of the present invention. It should be noted that it is not intended to exclude from the signal-delta modulator according to the third aspect of the disclosure, and the method of converting a signal according to the fourth aspect of the disclosure, the possibility of feedback to the digital filter.

25 BRIEF DESCRIPTION OF THE DRAWINGS

Preferred embodiments are now described, by way of example only, with reference to the accompanying drawings, in which:

Fig. 1 is a block diagram of a continuous-time $\Sigma\Delta$ modulator,

Fig. 2 is a block diagram of a continuous-time $\Sigma\Delta$ modulator in which the quantiser
30 is linearly modelled,

Fig. 3 is a block diagram of an example analogue loop filter, for use in the modulator of Figure 1, or in embodiments of the invention,

Fig. 4 shows the loop filter transfer function (H), noise transfer function (NTF), and signal transfer function (STF), for the modulator of Figure 1,

35 Fig. 5 shows a simulated frequency response of a 4th order $\Sigma\Delta$ modulator using the filter of Figure 3, with a full scale input signal,

Fig. 6 shows a 1-bit and a 5-bit modulator output signal, as alternatives for comparison,

Fig. 7 shows the output spectrum of a 4th order 1-bit and a 4th order 5-bit $\Sigma\Delta$ modulator, as alternatives for comparison,

5 Fig. 8 shows a $\Sigma\Delta$ modulator architecture according to an embodiment of the invention,

Fig. 9 shows a linearised model of the $\Sigma\Delta$ modulator architecture of Figure 8,

Fig. 10 shows graphs of example filter frequency response characteristics, for use in embodiments,

10 Fig. 11 shows another embodiment, showing a converter having a modulator and an additional digital filter,

Fig. 12 shows the output spectra of a conventional modulator and of an embodiment of the invention, having a 5th order 5-bit $\Sigma\Delta$ modulator.

15 DETAILED DESCRIPTION OF PREFERRED EMBODIMENTS

By way of introduction to the embodiments, the operation of a known $\Sigma\Delta$ modulator such as can be used for an ADC will be discussed. An ADC using a $\Sigma\Delta$ modulator (which will be termed a $\Sigma\Delta$ ADC) can provide a performance benefit in terms of allowing a high dynamic range of signals to be received for a small amount of power consumption. The power advantage of using such an $\Sigma\Delta$ ADC is only maximised if the digital filter following the $\Sigma\Delta$ modulator can be implemented efficiently. The highly over sampled output of a $\Sigma\Delta$ modulator places extra processing burden into the digital domain resulting in increased power consumption. The analogue side of the ADC (a 1-bit ADC/DAC and filter) can be relatively simple. The digital side performs filtering and decimation and makes the ADC
20 inexpensive to produce in practice.

The principle of operation of the $\Sigma\Delta$ modulator is well known. In summary, an input analogue information signal is fed to a feedback loop comprising a continuous-time analogue filter such as an integrator for noise shaping, followed by a quantiser which samples the signal and a feedback path using a DAC. The output signal of the $\Sigma\Delta$
30 modulator is a stream of bits at a highly oversampled rate. The oversampled bitstream is optionally fed to subsequent digital processing which converts the bitstream to a lower rate representation of the information signal by decimation and digital filtering, to provide a stream of values with more bits, and a lower sample frequency. The oversampling frequency is set to kf_s , where f_s is the Nyquist sampling frequency and k is the
35 oversampling ratio. The oversampling causes the noise floor to drop in the same bandwidth. The signal-to-noise ratio (SNR) in the frequency range $0-f_s$ is the same as

before, but the noise energy has been spread over a wider frequency range. $\Sigma\Delta$ ADCs exploit this effect by following the 1-bit ADC with a subsequent digital filter. An example of an embodiment of the invention having such a subsequent digital filter, SF, is shown in Fig. 11, described below. The RMS noise is reduced, because most of the noise is removed by this subsequent digital filter. This action enables $\Sigma\Delta$ ADCs to achieve wide dynamic range from a low-resolution quantiser. By summing an error voltage, which is the difference between the input signal and a feedback signal, the loop filter in the form of an integrator function, acts as a lowpass filter to its input signal. Most of the quantisation noise is pushed into higher frequencies where it is removed by digital filtering.

Oversampling and integrating has changed not the total noise power, but its distribution.

The subsequent digital filter can average the 1-bit data stream, improve the ADC resolution, and remove quantisation noise that is outside the band of interest. It determines the signal bandwidth, settling time, and stopband rejection. The subsequent digital filter is after the $\Sigma\Delta$ modulator, and should not be confused with the digital filter of the $\Sigma\Delta$ modulator as described below. A comparative example illustrating some features of a $\Sigma\Delta$ modulator 100 is shown for reference purposes in Figure 1. The $\Sigma\Delta$ modulator 100 comprises an analogue input 15 for receiving an input signal X, an analogue loop filter 20, a multi-bit quantiser 30 with sample frequency f_s , a digital output 17 for providing an output signal Y, a feedback DAC 40 for calculating the analogue representation of the quantised signal, and a summing stage 10 for calculating an error signal as the difference between the input signal X and the quantised signal. To the $\Sigma\Delta$ modulator 100 a sample frequency of $f_s = k \times 2 \times f_{BW}$ is applied, where f_{BW} is the signal bandwidth. The oversampling ratio k indicates how many times the sample frequency is higher than the sample frequency defined by Nyquist. In order to have a high signal-to-noise ratio the quantiser 30 should have a high-resolution.

In order to calculate the analogue representation of the quantised signal, the DAC 40 should have the same resolution as the quantiser 30. Unfortunately in practice it is difficult to provide such a DAC 40 with sufficient linearity, due to non-linearities in the feedback. DAC 40 quantisation noise can fold back into the signal bandwidth, which decreases the maximum signal-to-noise-and-distortion ratio (SDNR). Furthermore non-linearities in the DAC 40 will also cause harmonic distortion of the input signal.

The $\Sigma\Delta$ modulator 100 of Figure 1 can be modelled with the scheme shown in Fig. 2, where the quantiser 30 is replaced by a quantisation noise source having a noise N and a gain C, which represents the gain of the quantiser. From this model the transfer function can be calculated as:

$$Y = \frac{C.H}{1+C.H} X + \frac{C}{1+C.H} N \quad (1)$$

where H is the transfer function of the loop filter 20. For the loop filter 20, a low pass filter implemented with integrators is assumed, which has very high gain for low frequencies and has a certain order roll-off for higher frequencies. At low frequencies the signal X at the input 15 is amplified to the output 17 with a factor of one because of the high gain in the loop filter 20, and the quantisation noise is suppressed with this gain. At high frequencies the loop filter 20 has a low gain and the noise rises with the loop filter order. This is an arbitrarily chosen $\Sigma\Delta$ converter. It can be of any order and any number of bits.

In Fig. 3, a block diagram of a 4th order loop filter is shown as an example. This can be used in embodiments of the invention such as the embodiment of Fig. 8. It can be implemented using analogue circuitry or digital circuitry. A first integrator 70 is followed by a first clipping circuit 80. An output of the first clipping circuit 80 is amplified by a first amplifier 90 having a gain a_1 . The output of the first clipping circuit 80 is also fed along a chain of further integrators 72, 74, 76 and clipping circuits 82, 84, 86 coupled in series. At each stage, the output of each clipping circuit 82, 84, 86 is fed to respective amplifiers 92, 94, 96 having respective gains a_1 , a_2 , a_3 and a_4 . The outputs of the amplifiers 90, 92, 94, 96 are summed by a summing stage 98 to provide the overall output of the loop filter 20. Filters of other orders can be provided by altering the number of integrators in the chain.

For high frequencies, the loop transfer function is reduced to first order by the feed-forward gain coefficients a_2 , a_3 and a_4 to ensure loop stability. The clip levels are implemented to ensure stability at large amplitude input signals.

In Fig. 4, the transfer function H of the 4th order loop filter 20 is shown (upper of the three lines) together with the closed loop Signal Transfer Function (STF, middle line of the three lines) and Noise Transfer Function (NTF, lower of the three lines). The STF and NTF are defined below :

$$\text{STF} = \frac{Y}{X} = \frac{C.H}{1+C.H} \quad (2a)$$

$$\text{NTF} = \frac{Y}{N} = \frac{C}{1+C.H} \quad (2b)$$

The order of the loop filter can be read from the plot and indeed is 4th order. The noise transfer function rises 4th order with frequency.

In the STF a bump is present, caused by the limited phase margin of the loop filter H. At high frequencies the loop has to return to first order for loop stability, but lowering the return-to-first-order frequency will reduce the suppression of quantisation noise in the

signal bandwidth, which is unwanted. So a trade-off has to be made between phase margin and suppression of quantisation noise.

A simulated frequency response of the $\Sigma\Delta$ modulator 100 of Figure 1 is shown in Fig. 5. The signal-to-noise ratio calculated from the plot is 68 dB in a 2MHz bandwidth at a sample rate of 153.6 MHz. The 4th order noise shaping can be recognised in the spectrum.

The quantiser 30 and DAC 40 in a $\Sigma\Delta$ modulator 100 are normally of the same resolution and can be 1-bit or multi-bit. An output bit-stream of a 1-bit and a 5-bit $\Sigma\Delta$ modulator are displayed in Figure 6, together with an ideal input sine wave, where n is the number of quantisation levels, respectively 2 and 32. The 1-bit stream varies between 1 and -1, while the 5-bit stream is close to the ideal, that is the analogue sine wave prior to quantisation.

When comparing the two bit-streams it is easy to see that the quantisation noise is smaller when a multi-bit quantiser and DAC combination is used. The improvement in quantisation noise, going from 2 level to a higher number of levels 2^w , for a w-bit quantiser, can be calculated with the formula below :

$$\frac{N_{1-bit}}{N_{x-bit}} = 20\log_{10}(2^w - 1) \tag{3}$$

This formula indicates an improvement of approximately 6dB for each bit of a multi-bit quantiser. When comparing the sinewaves in Figure 6, which indicate the maximum input signal, another thing that can be seen from the bit-streams is that the input amplitude can be larger in a multi-bit modulator when compared to a 1-bit modulator. The maximum signal-to-quantisation-noise ratio (SQNR) is given by the following formula:

$$\frac{V_{in,max,w}}{V_{in,max,2}} = 20\log\left(\frac{0.5\sqrt{2} + n - 2}{n - 1} \cdot \frac{1}{0.5\sqrt{2}}\right) \tag{4}$$

where $V_{in,max,w}$ is the maximum amplitude of the input signal for a w-bit quantiser, which has 2^w quantisation levels, and $V_{in,max,2}$ is the maximum amplitude of the input signal for a 1-bit quantiser, which has 2 levels.

A simulated noise amplitude of a 1-bit and 5-bit modulator is shown in Figure 7 for a resolution bandwidth (RBW) of 10kHz, the lower of the two lines being for the 5-bit modulator, and the upper line being for the 1-bit modulator. From simulation a SQNR of 67.7dB is derived for the 1-bit modulator and a SQNR of 101.1dB for the 5-bit modulator.

This is an improvement of about 33dB when going from 1-bit to 5-bit. A theoretical estimation yields 29.8 dB improvement in SQNR from formula 3 and 2.9 dB from formula 4.

A problem of multi-bit $\Sigma\Delta$ modulators is the linearity in the DAC 40. Due to non-linearities in the feedback DAC 40, quantisation noise can fold back into the signal bandwidth, which decreases the maximum achievable SNDR. Furthermore non-linearities in the DAC 40 will also cause harmonic distortion of the input signal.

5 Static and dynamic non-linearities can occur in the feedback DAC 40. Static non-linearities originate from mismatches in the feedback DAC 40 unit cells. These unit cells implemented with resistors, capacitors or current sources are used to create the different output levels in the DAC 40 and when there are mismatches in these unit cells the transfer curve of the DAC 40 will not be a straight line. Based on experience, static DAC linearities
10 of about 60-70 dB are achievable, depending on the implementation of the unit cell. To reduce the static non-linearities in the DAC 40, Dynamic Element Matching (DEM) and Data Weighted Averaging (DWA) techniques can be used, of which the topologies are well known and will not be discussed here. Dependent on their implementation, extra chip area and a higher sample frequency is often needed to facilitate the improvement
15 scheme. Furthermore the improvement in SNDR is only small.

The second non-linearity that occurs in multi-bit modulators is of the dynamic kind. A dynamic non-linearity occurs when switching charges are not the same at every DAC output level, for example due to parasitics. At high speeds this becomes more severe and has to be considered very carefully in circuit design and layout.

20 A special kind of 1-bit modulator is a 1.5 bit modulator. In this modulator both the quantiser 30 and feedback DAC 40 have three levels (+1, 0, -1). In the middle level, the feedback current is zero, which is easy to implement in circuit design. In 1.5 bit modulators good static linearity of the feedback DAC 40 is rather easy to achieve.

In prior multi-bit $\Sigma\Delta$ modulator solutions, the feedback DAC 40 is also multi-bit, and
25 the dynamic linearity problem can be solved in different ways:

Dynamic Element Matching / Data Weighted Averaging. This class of techniques to linearise the DA 40 is limited by the order of the loop filter 20, and often needs a higher clock frequency than the sample frequency f_s used for the $\Sigma\Delta$ modulator 100.

30 Barrel shifting of unit elements. In this technique the unit cells of the DAC 40 are rotated in use, which gives only a small improvement in linearity.

Calibration of current sources. The calibration of current sources improves the linearity of the DAC 40, and linearities up to 14-bit are shown in publications, but this kind of linearising techniques is quite complicated to design.

35 The embodiments of the invention involve a different approach, but these known approaches, or features of them can also be combined with the different approach of the embodiments described.

The embodiments of the invention described relate to apparatus or methods for providing more linear feedback to a multi-bit modulator. In some embodiments a $\Sigma\Delta$ modulator is provided comprising a signal processing chain with successively a loop filter, an n-bit quantiser, a digital filter and a 1-bit quantiser. Some embodiments of the invention as will be described below can comprise in addition to the standard noise shaping loop filter 20 and a multi-bit quantiser 30, a digital filter for filtering the output of the multi-bit quantiser 30 and a 1-bit quantiser for quantising the output of the digital filter and providing the output signal Y and the feedback signal. On the one hand the 1-bit quantiser is inherently linear. On the other hand the presence of the multi-bit quantiser 30 enables part of the loop-filtering to be handled by the digital filter. Alternatively, a further multi-bit quantiser can be used in place of the 1-bit quantiser. The digital filter can have a frequency characteristic which can be shaped more flexibly so as to provide a much better suppression of the noise in the frequency region of interest, without being subject to process imperfections. Where gain is provided by the digital filter, it is not essential that a single filter provides the gain characteristic; instead the digital filter can be implemented as two or more filters in series, such as one to provide the gain in the first frequency band of interest, and another to provide a flat gain at higher frequencies.

Additional features can be as follows. These features are not necessarily essential to all embodiments; they can be omitted or substituted.

The digital filter can have an order greater than one in the passband of the $\Sigma\Delta$ modulator. The gain characteristic of the digital filter outside of the passband of the $\Sigma\Delta$ can have a flat gain profile. The feedback signal can comprise a 1-bit signal. The feedback signal can comprise a most significant bit of an output of the digital filter. The loop filter 20 can comprise any of a continuous time filter, a switched capacitor filter, or a digital filter. In the case of a digital filter, a converter would be used to convert the analogue input to a digital signal for input to the digital loop filter 20. The loop filter 20 can comprise a first order or higher order filter. The loop filter 20 can comprise an integrator. The digital filter can have a gain in the passband of the $\Sigma\Delta$ modulator which exceeds the gain outside the passband of the $\Sigma\Delta$ modulator by at least $20\log_{10}((2^y-1)/(2^z-1))$ dB, where y is the number of bits of the feedback signal and z is the number of bits of the multi-bit quantiser 30. The frequency response of the combination of the loop filter and the digital filter may have a first order roll-off of gain outside of the passband of the sigma-delta modulator. The analogue loop filter 20 and digital filter can be implemented as a bandpass filter, yielding a bandpass $\Sigma\Delta$ modulator.

The above mentioned US6404368 document needs stability analysis of multiple loops, while the embodiments of the present invention only have one loop. To contrast

with US6404368, a simulation of a $\Sigma\Delta$ ADC in accordance with the invention is also described below.

Referring to the embodiment of the $\Sigma\Delta$ modulator 200 shown in Figure 8, elements which are identical to those of Figure 1 have the same reference numerals. The feedback
 5 loop contains the loop filter 20 discussed above, the multi-bit quantiser 30, a digital filter 50, and a 1-bit quantiser 60. If we leave out the digital filter 50 and the 1-bit quantiser 60, the loop would be a conventional $\Sigma\Delta$ loop (as in Figure 1), with the loop filter 20 providing the noise shaping function, and the multi-bit quantiser 30 lowering the quantisation noise by 6x dB, where x is the number of bits of the multi-bit quantiser, as discussed above.

10 The DAC 40 should be linear to avoid high frequency quantisation noise folding back into the signal band.

Gain greater than 0dB in the passband of the $\Sigma\Delta$ modulator 200 may be introduced between the multi-bit quantiser 30 and 1-bit quantiser 60 by the digital filter 50.

The digital filter 50 can suppress the quantisation noise introduced by the 1-bit
 15 quantiser 60. An output 117 can be taken from after the 1-bit quantiser 60. An alternative to the 1-bit quantiser 60 is to use multiple bits, provided fewer bits are taken than the number of bits provided by the multi-bit quantiser 30 to the digital filter 50. Other elements can be added into the loop to suit particular applications. The $\Sigma\Delta$ modulator presented in Figure 8 can be linearised, which leads to the model presented in Fig. 9.

20 In Fig. 9, Q_1 represents the quantisation noise of the multi-bit quantiser 30, and Q_2 represents the quantisation noise of the 1-bit quantiser 60. The output signal Y at the output 117 can be calculated in terms of the input signal X at the input 15 as:

$$Y = \frac{HF}{1+HF} X + \frac{F}{1+HF} Q_1 + \frac{1}{1+HF} Q_2 \quad (5)$$

where H is the transfer function of the loop filter 20, F is the transfer function of the
 25 digital filter 50, Q_1 is the quantisation noise due to the multi-bit quantiser 130, and Q_2 is the quantisation noise due to the 1-bit quantiser 60. As can be seen from the formula above, when the loop filter 20 and the digital filter 50 have a high gain in the pass band of the $\Sigma\Delta$ modulator 200, the input signal X is amplified by one to the output signal Y in the passband. Q_1 is suppressed by the gain of the loop filter 20, as in a conventional $\Sigma\Delta$
 30 modulator. Q_2 is suppressed by the product of H and F, and is even more suppressed compared to Q_1 , if the digital filter 50 has a high gain in the passband of the $\Sigma\Delta$ modulator 200. Alternatively, the digital filter 50 need not have a high gain provided it has a high gain difference of at least $20\log_{10}((2^y-1)/(2^z-1))$ dB between the passband and outside of the passband of the $\Sigma\Delta$ modulator. To get the full advantage of the multi-bit quantiser 30, Q_2
 35 has to be below Q_1 , calculated to the output 17. As described above, adding a bit in the

multi-bit quantiser 30, would lower quantisation noise introduced by the multi-bit quantiser 30 by about 6dB.

So, compared to the 1-bit quantiser 60, the performance of the $\Sigma\Delta$ modulator 200 would be about 6.2 dB better. If an example of a 5-bit quantiser is taken, this would mean that the quantisation noise of the 5-bit quantiser when used for the multi-bit quantiser 30 is about 30dB below that of the 1-bit quantiser 60. This means that the digital filter 50 needs more than about 30dB of gain in the passband to get Q_2 below Q_1 , to get the full advantage of the multi-bit quantiser 30 together with the 1-bit quantiser 60, which inherently provides a linear feedback path. Alternatively, the digital filter 50 needs at least about 30dB gain difference between the passband and outside of the passband of the $\Sigma\Delta$ modulator. The exact figures can be calculated as $20\log_{10}((2^Y-1)/(2^Z-1))$ dB.

Fig. 10 shows three graphs of the amplitude of the frequency response. The left graph is an example of the response $|H|$ of loop filter 20; the middle graph shows an example of the response $|F|$ of the digital filter 50; and the right graph shows the combined response $|HF|$ of the loop filter 20 and the digital filter 50. As mentioned above, the digital filter 50 should have high gain, or a high gain difference, in a first band of frequencies, for example in the bandwidth of the input signal X, or equivalently in the passband of the $\Sigma\Delta$ modulator, to suppress the level of the quantisation noise Q_2 below the level of Q_1 . The gain at higher frequencies should be lower, preferably by at least $20\log_{10}((2^Y-1)/(2^Z-1))$ dB. Another constraint is that the digital filter 50 should not jeopardize the stability of the loop. Hence in some embodiments, to reduce or avoid instability of the loop, the digital filter 50 should have flat gain outside of the passband of the $\Sigma\Delta$ modulator, in order to avoid excessive phase shift at high frequencies, which can make the loop unstable. If the group delay at high frequencies introduced by the digital filter 50 is kept low, the loop will remain stable with little or no change to the set of gain coefficients in the loop filter 20 compared with the gain coefficients required for the loop filter 20 for a conventional $\Sigma\Delta$ modulator 100. Thus, the frequency response of the combination of the loop filter and the digital filter can provide a first order roll-off of gain outside of the passband of the sigma-delta modulator.

From the right-hand graph in Figure 10 it can be seen that in the signal bandwidth there is more gain compared to the left graph (the difference is $|F|$). The quantisation noise of Q_2 will not only be suppressed by the loop filter 20 but also by the digital filter 50. From the same graphs it can be seen that the stability of the $\Sigma\Delta$ modulator 200 remains unchanged, compared with a conventional $\Sigma\Delta$ modulator 100, because the frequency response of the digital filter 50 is flat and does not have excessive phase shift at high frequencies. Because the stability of the loop filter 20 is determined by the feedforward

gain coefficients a_1, a_2, a_3, a_4 of the analogue loop filter 20, no additional feedback paths will be required. This helps make the design of such a $\Sigma\Delta$ modulator much simpler.

In the graphs of Fig.10, the transition in the frequency response H of the loop filter 20 between a first order response and a higher order response occurs at the same
5 frequency as the bandwidth of the digital filter 50. However this is not an essential requirement, and the transition may occur at a higher or lower frequency.

Advantageously the gain profile of the digital filter 50 should be flat, and not exceed one outside the passband of the digital filter 50. In order to ensure the stability of a feedback loop, typically the first order slope of the gain profile of the filtering in the loop, in
10 this case the combination of the loop filter 20 and the digital filter 50, has to go through 0dB .

The loop filter 20 of a conventional $\Sigma\Delta$ modulator 100 has this first order slope, so if another slope in the characteristic is added into the loop, it will tend to become unstable. Therefore, by providing the digital filter 50 with a gain profile that is flat, and does not
15 exceed one outside the passband of the digital filter 50, the coefficients of a conventional $\Sigma\Delta$ modulator 100 typically do not need to be altered. Clearly the gain characteristic can be a band pass characteristic, with lower gain at frequencies above and below the signal band.

Fig. 11 shows an embodiment of an analogue-to-digital converter 300 employing
20 the $\Sigma\Delta$ modulator 200 shown in Figure 8. The output signal Y of the $\Sigma\Delta$ modulator 200 is fed to an input of a subsequent digital filter 70 having a transfer function SF.

In Fig. 12, the output spectrum over a range of 100 Hz to 300 MHz on a logarithmic scale, of a conventional 5th order $\Sigma\Delta$ modulator 100 comprising a 5-bit quantiser is shown (lower plot). The figure also shows the output spectrum of the new
25 architecture according to the invention (upper plot), which in this case is also implemented with a 5th order loop filter 20 and a 5-bit quantiser 30. The $\Sigma\Delta$ modulator 200 in this case uses a digital filter 50 which has 30dB gain in the passband of 500kHz and 0dB gain at higher frequencies.

The signal-to-noise ration (SNR) of the new $\Sigma\Delta$ modulator 200 is 134.3dB, about
30 4dB worse compared to the conventional $\Sigma\Delta$ modulator 100 which has a SNR of 138.4dB. This is due to the gain of the digital filter 50. As indicated above, the gain of the digital filter 50 in the pass band of the $\Sigma\Delta$ modulator 200, or gain difference inband and out-of-band, should be at least $20\log_{10}((2^y-1)/(2^z-1))$ dB. This is not the case in this example; the gain is 30dB which is just enough to attenuate Q_2 to the same level as Q_1 , which means
35 the total noise rises by 3dB compared to the conventional $\Sigma\Delta$ modulator 100. This can be improved by increasing the gain, or inband and out-of-band gain difference, in the digital

filter 50. At high frequencies the quantisation noise is higher for the new architecture compared to the conventional architecture. This is the quantisation noise of the 1-bit quantiser because the digital filter 50 has 0dB gain at high frequencies.

Embodiments of the invention can benefit from the fact that there is a multi-bit
5 quantiser 30 in the loop, can benefit from the advantages of a 1-bit inherently linear feedback DAC 40, and can have a higher degree of digitisation because a multi-bit DAC which has to be very linear, (therefore needing precision analogue parts) is replaced by a digital filter.

An example application in a radio frequency (RF) receiver or other system can
10 have an ADC comprising the $\Sigma\Delta$ modulator 200 and followed by an adaptable digital filter for channel selection or noise removal, or other purpose. A detector determines a level of interference from outside the desired signal band, and feeds this information forward to the adaptable filter. Other analogue circuitry stages can precede the ADC, and other digital processing stages can follow the adaptable digital filter. There can also be other
15 digital processing stages before the adaptable filter, such as automatic gain control (AGC). The arrangement can form part of a wireless receiver, or can be applied to other systems susceptible to changing interfering signals. The interference information can optionally be fed forward to other subsequent circuit stages such as an equaliser, or a demodulator for example. The amount of processing by these subsequent stages can be
20 adjusted according to the information, to suit different conditions. For example the number of least significant bits used can be changed or a number of filtering stages changed to save power consumption.

Also, optionally the detector can be fed from the analogue signal before the ADC. In this case, a relatively simple filter can be implemented in the detector by means of
25 analogue components, or the signal can be converted to digital format and a simple digital filter can be implemented with a relatively low number of coefficients and a relatively low update rate.

In a receiver having an adaptable digital filter and a $\Sigma\Delta$ ADC, the adaptable digital filter can combine the decimation function for the ADC and the channel filter function. This
30 can be implemented in an ASIC (application specific integrated circuit) or FPGA (field programmable gate array) type circuit, or can be carried out by a DSP (digital signal processor), as desired. A DSP can be provided for subsequent digital processing such as demodulation, equalisation and so on.

The receiver can have an antenna, and conventional analogue circuitry such as an
35 RF filter, followed by a mixer for mixing a local oscillator signal LO. An analogue low pass filter is followed by the $\Sigma\Delta$ ADC. This feeds a digital signal to the adaptable digital filter,

which is adapted according to the unwanted signal information, to adapt the channel filter function to optimise it for power efficiency. The detector can be much simpler than the adaptable digital filter, to save power or reduce complexity. Notably, the adaptation of the digital filter processing can be relatively autonomous, in other words independent of
5 higher levels of software controlling a system or applications using the circuitry, and so need not add complexity to the interface to such software. The detection information can include power levels, averaged levels, frequencies, frequency ranges, comparisons to thresholds, comparisons to wanted parts of the signal, combinations of these and so on.

Another application as an alternative to an ADC is a digital-digital noise shaper. In
10 this embodiment, the arrangement of Figure 8, or of Figure 11 can be used, with the loop filter 20 being a digital filter, and the input signal X being a digital signal rather than an analogue signal. The quantiser 30 in this case acts as a re-sampler, taking a number of samples at a low quantisation level, and outputting a single sample at a higher quantisation level. Also, the DAC 40 can be omitted from the feedback path and the
15 summing stage 10 implemented digitally. Other variations and additions can be envisaged within the scope of the claims.

The present invention has been described with respect to particular embodiments and with reference to certain drawings but the invention is not limited thereto but only by
20 the claims. The drawings described are only schematic and are non-limiting. Where the term "comprising" is used in the present description and claims, it does not exclude other elements or steps. Where an indefinite or definite article is used when referring to a singular noun e.g. "a" or "an", "the", this includes a plural of that noun unless something else is specifically stated. The term "comprising", used in the claims, should not be
25 interpreted as being restricted to the means listed thereafter; it does not exclude other elements or steps. References to numerical values or ranges are approximate.

CLAIMS:

1. A sigma-delta modulator comprising:
 - a summing stage for generating an error signal as the difference between an input signal and a feedback signal;
 - a loop filter coupled to an output of the summing stage for filtering the error signal;
 - a multi-bit quantiser coupled to an output of the loop filter for quantising the filtered error signal;
 - a digital filter coupled to an output of the multi-bit quantiser; and
 - a feedback path coupling an output of the digital filter to the summing stage for providing the feedback signal to the summing stage,
wherein the feedback signal has fewer bits than a number of bits produced by the multi-bit quantiser and there is no other feedback path coupling the output of the digital filter to an input of the digital filter.

- 5 2. The sigma-delta modulator of claim 1, the digital filter having an order greater than one in a passband of the sigma-delta modulator.

- 10 3. A sigma-delta modulator comprising:
 - a summing stage for generating an error signal as the difference between an input signal and a feedback signal;
 - 10 - a loop filter coupled to an output of the summing stage for filtering the error signal;
 - a multi-bit quantiser coupled to an output of the loop filter for quantising the filtered error signal;
 - a digital filter coupled to an output of the multi-bit quantise;
 - 15 - a feedback path coupling an output of the digital filter to the summing stage for providing the feedback signal to the summing stage, the feedback signal having fewer bits than a number of bits produced by the multi-bit quantiser,
wherein the digital filter has an order greater than one in a passband of the sigma-delta modulator.
 - 20

4. The sigma-delta modulator of claim 2 or 3, wherein the frequency response of the digital filter has a substantially flat gain outside of the passband of the sigma-delta modulator.

5. The sigma-delta modulator of claim 4, wherein the difference in gain of the digital filter inside and outside of the passband of the sigma-delta modulator is greater than or equal to $20\log_{10}((2^y-1)/(2^z-1))$ dB, where y is the number of bits of the feedback signal and z is the number of bits of the multi-bit quantiser.
6. The sigma-delta modulator of any preceding claim, wherein the frequency response of the combination of the loop filter and the digital filter has a first order roll-off of gain outside of the passband of the sigma-delta modulator.
7. The sigma-delta modulator of any preceding claim, comprising a 1-bit quantiser coupled to the output of the digital filter for generating the feedback signal as a 1-bit feedback signal.
8. The sigma-delta modulator of claim 7, the 1-bit quantiser being arranged to feed back a most significant bit of an output of the digital filter.
9. The sigma-delta modulator of any preceding claim, wherein the feedback path includes a digital-to-analogue converter.
10. The sigma-delta modulator of any preceding claim, the loop filter comprising any of a continuous time filter, a switched capacitor filter, or a digital filter.
11. The sigma-delta modulator of any preceding claim, the loop filter comprising a filter of order greater than one.
12. The sigma-delta modulator of any preceding claim, the loop filter comprising an integrator.
13. The sigma-delta modulator of any preceding claim, the loop filter and the digital filter having a bandpass amplitude response.
14. A digital-to-analogue converter having the modulator of any preceding claim and a further digital filter coupled to the output of the digital filter.
15. A method of converting a signal comprising:

- generating an error signal as the difference between an input signal and a feedback signal;
 - filtering the error signal;
 - quantising the filtered error signal using a multi-bit quantiser;
 - 5 - filtering the quantised and filtered error signal using a digital filter; and
 - generating the feedback signal from an output of the digital filter,
wherein the feedback signal has fewer bits than a number of bits produced by the multi-bit quantiser and there is no other feedback of the output of the digital filter to an input of the digital filter.
- 10
16. A method of converting a signal comprising:
- generating an error signal as the difference between an input signal and a feedback signal;
 - filtering the error signal;
 - 15 - quantising the filtered error signal using a multi-bit quantiser;
 - filtering the quantised and filtered error signal using a digital filter; and
 - generating the feedback signal from an output signal of the digital filter,
wherein the feedback signal has fewer bits than a number of bits produced by the multi-bit quantiser, and
- 20 wherein the digital filter has an order greater than one in a passband of the sigma-delta modulator.

1/6

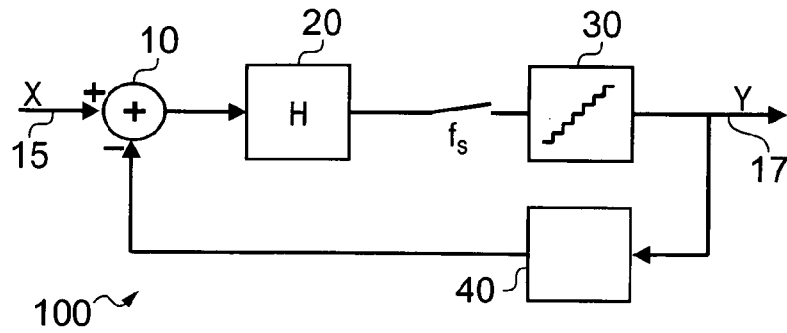

FIG. 1

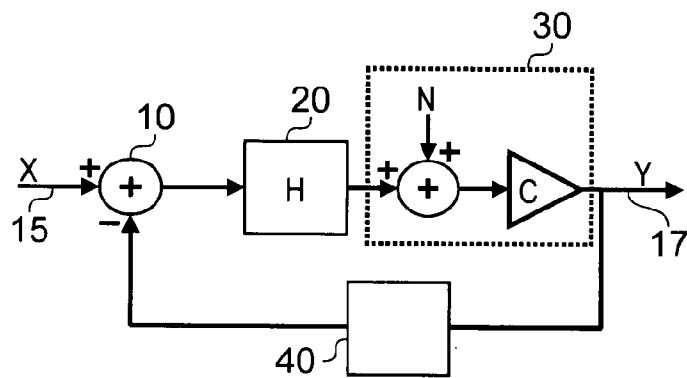

FIG. 2

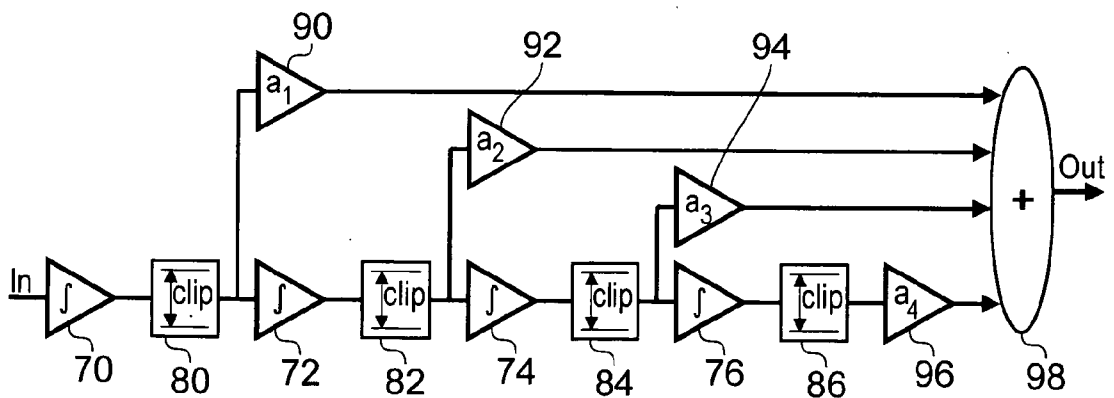

FIG. 3

2/6

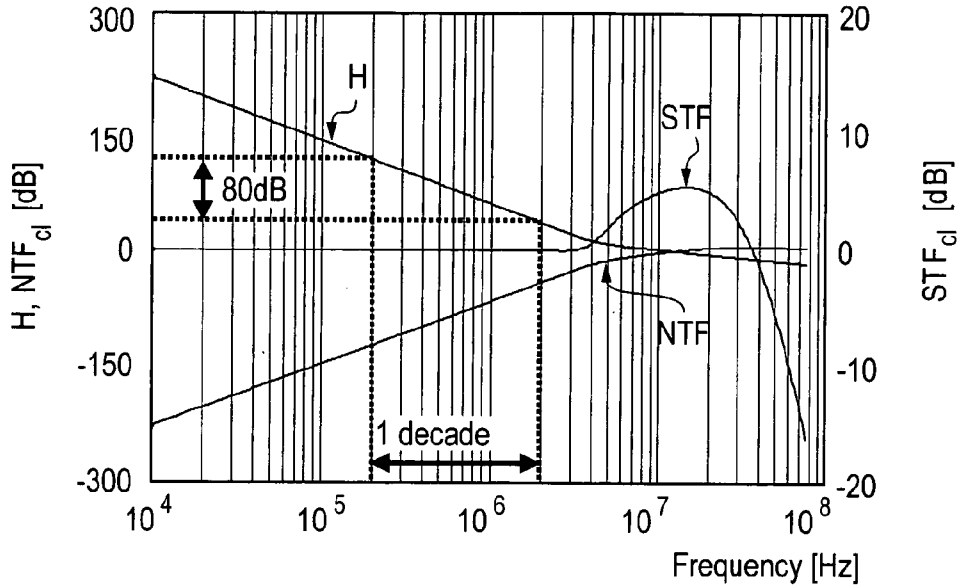

FIG. 4

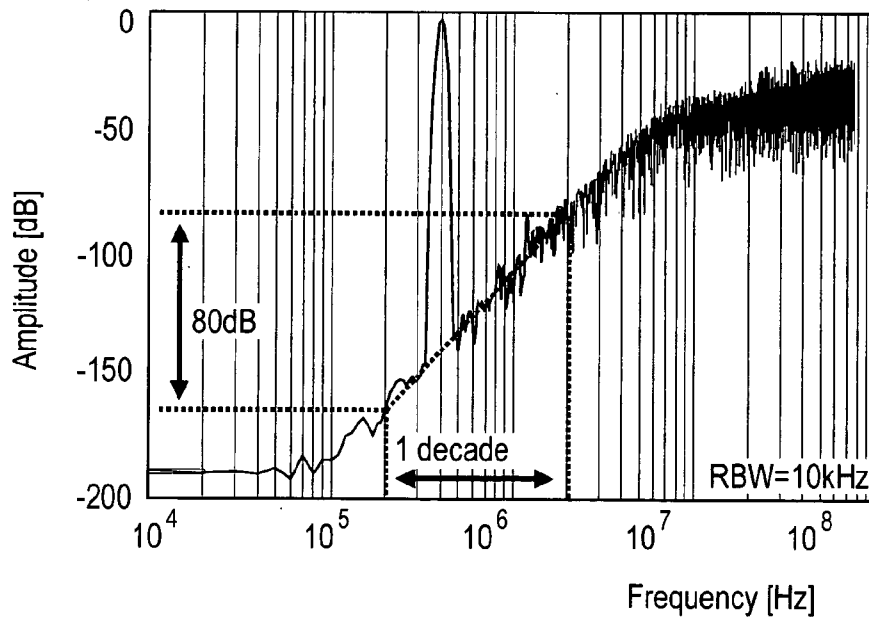

FIG. 5

3/6

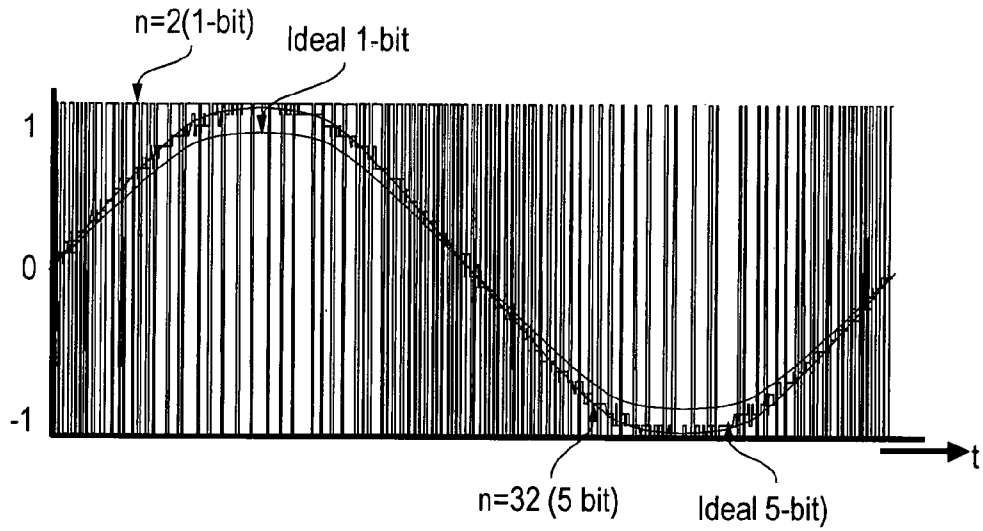

FIG. 6

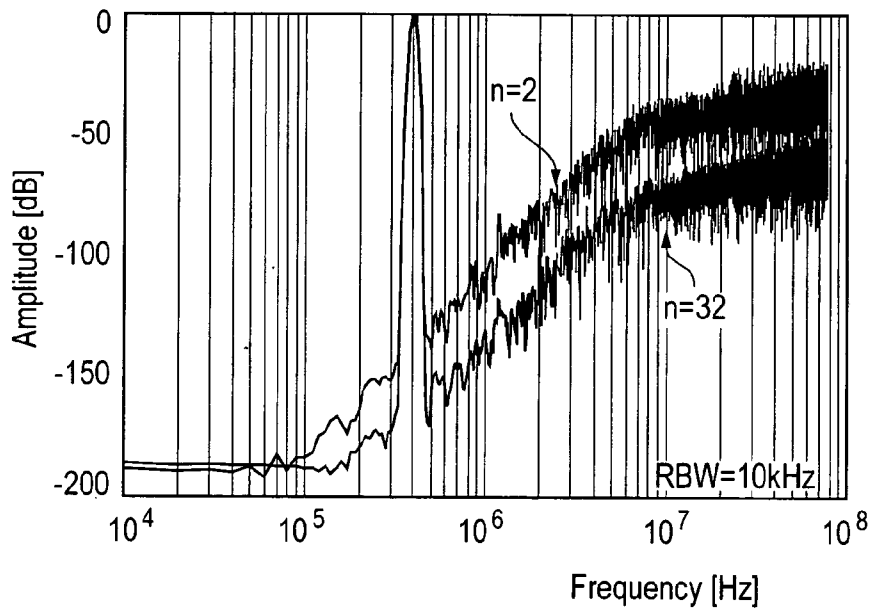

FIG. 7

4/6

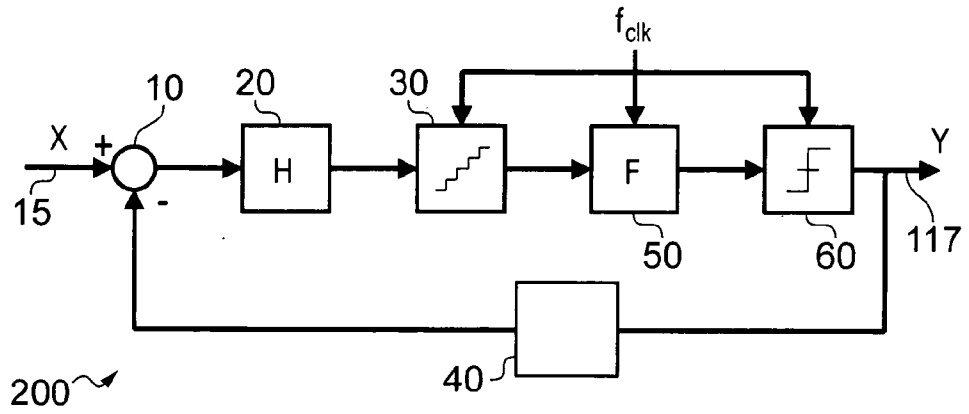

FIG. 8

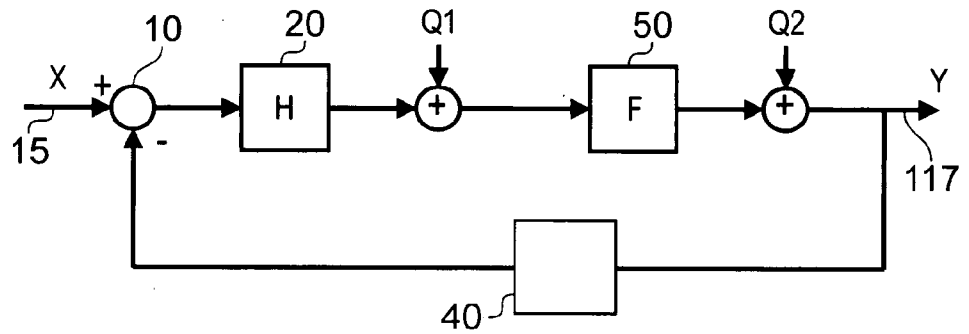

FIG. 9

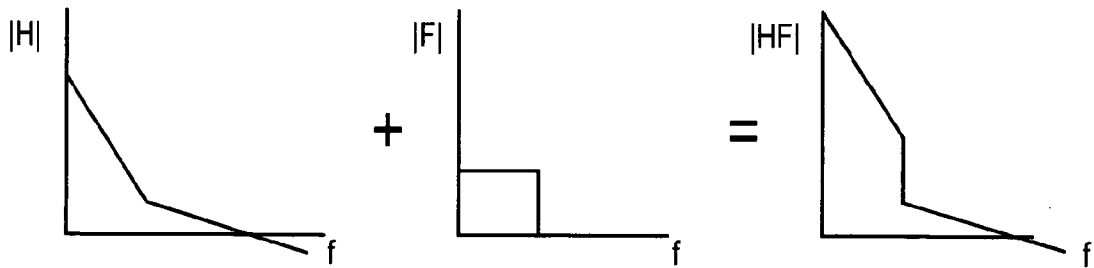

FIG. 10

5/6

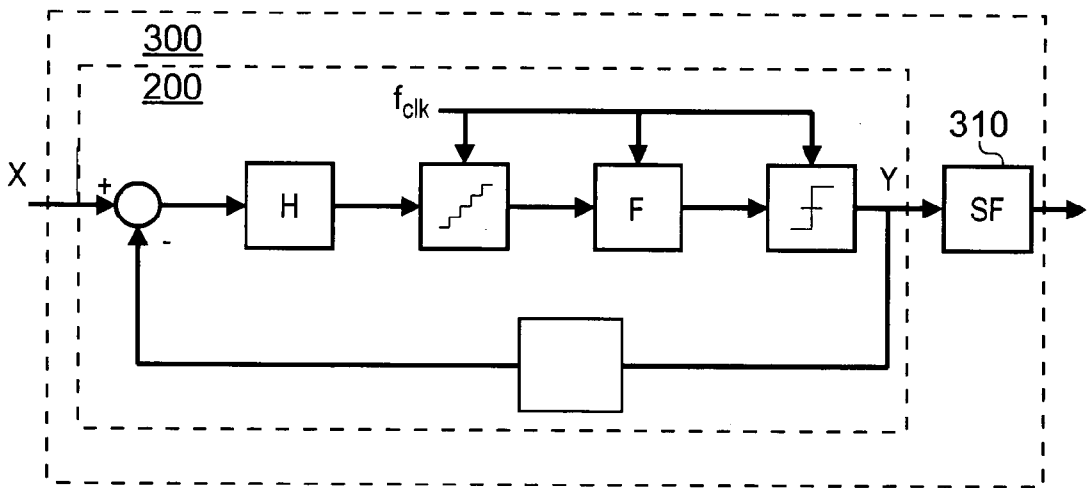

FIG. 11

6/6

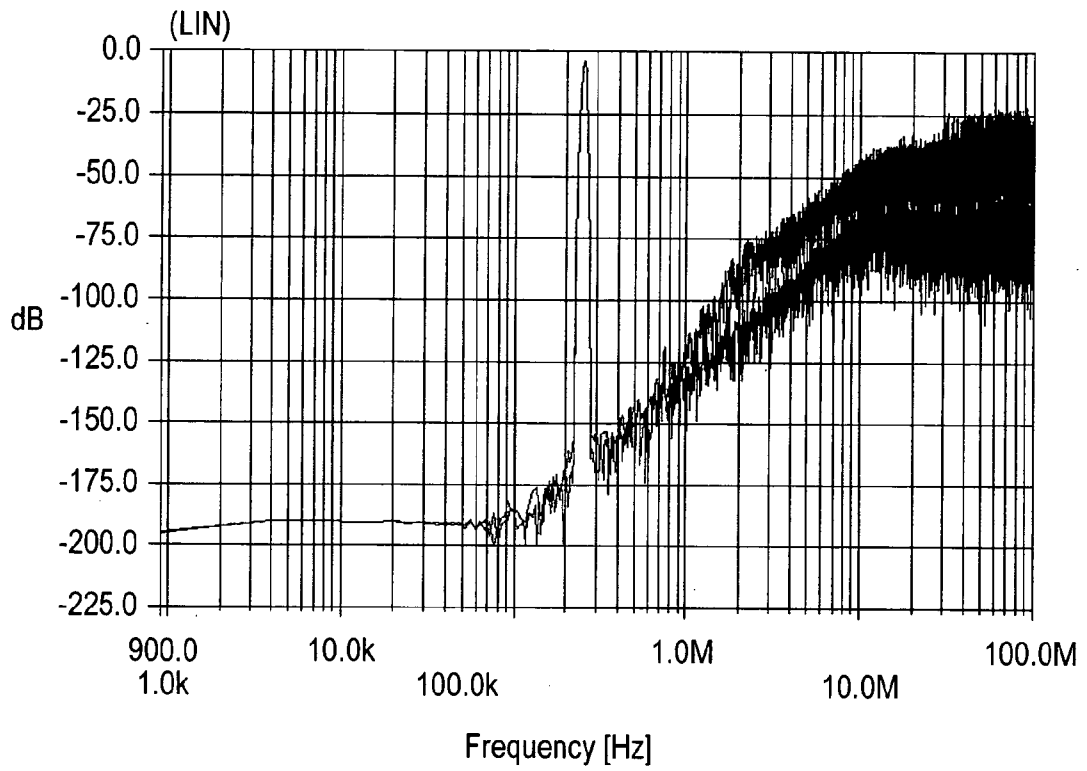

FIG. 12

INTERNATIONAL SEARCH REPORT

International application No
PCT/EP2008/010879

A. CLASSIFICATION OF SUBJECT MATTER
INV. H03M3/02 H03M3/04

According to International Patent Classification (IPC) or to both national classification and IPC

B. FIELDS SEARCHED

Minimum documentation searched (classification system followed by classification symbols)
H03M

Documentation searched other than minimum documentation to the extent that such documents are included in the fields searched

Electronic data base consulted during the international search (name of data base and, where practical, search terms used)

EPO-Internal, WPI Data, COMPENDEX, INSPEC, IBM-TDB

C. DOCUMENTS CONSIDERED TO BE RELEVANT

Category*	Citation of document, with indication, where appropriate, of the relevant passages	Relevant to claim No.
X Y	US 6 313 774 B1 (ZARUBINSKY MICHAEL [IL] ET AL) 6 November 2001 (2001-11-06) column 6, lines 53-65; figure 3	1, 9, 10, 12-15 2
X Y	----- US 6 404 368 B1 (YAMAGUCHI MOTOI [JP]) 11 June 2002 (2002-06-11) cited in the application column 6, lines 14-20; figures 3,5 column 8, lines 14-26 column 9, lines 4-9 -----	3, 7-9, 11, 12, 16 2

Further documents are listed in the continuation of Box C.

See patent family annex.

* Special categories of cited documents :

- *A* document defining the general state of the art which is not considered to be of particular relevance
- *E* earlier document but published on or after the international filing date
- *L* document which may throw doubts on priority claim(s) or which is cited to establish the publication date of another citation or other special reason (as specified)
- *O* document referring to an oral disclosure, use, exhibition or other means
- *P* document published prior to the international filing date but later than the priority date claimed

- *T* later document published after the international filing date or priority date and not in conflict with the application but cited to understand the principle or theory underlying the invention
- *X* document of particular relevance; the claimed invention cannot be considered novel or cannot be considered to involve an inventive step when the document is taken alone
- *Y* document of particular relevance; the claimed invention cannot be considered to involve an inventive step when the document is combined with one or more other such documents, such combination being obvious to a person skilled in the art.
- *&* document member of the same patent family

Date of the actual completion of the international search

14 May 2009

Date of mailing of the international search report

25/05/2009

Name and mailing address of the ISA/

European Patent Office, P.B. 5818 Patentlaan 2
NL - 2280 HV Rijswijk
Tel. (+31-70) 340-2040,
Fax: (+31-70) 340-3016

Authorized officer

Beindorff, Henk

INTERNATIONAL SEARCH REPORT

Information on patent family members

International application No

PCT/EP2008/010879

Patent document cited in search report	Publication date	Patent family member(s)	Publication date
US 6313774	B1	06-11-2001	NONE
US 6404368	B1	11-06-2002	JP 3407871 B2 19-05-2003 JP 2001094429 A 06-04-2001