

(19) World Intellectual Property Organization
International Bureau



(43) International Publication Date
30 April 2009 (30.04.2009)

PCT

(10) International Publication Number
WO 2009/054709 A2

(51) International Patent Classification:

G02B 27/22 (2006.01) G02B 5/32 (2006.01)
H04N 13/00 (2006.01)

(21) International Application Number:

PCT/LT2008/000009

(22) International Filing Date: 21 October 2008 (21.10.2008)

(25) Filing Language: English

(26) Publication Language: English

(30) Priority Data:

2007 066 22 October 2007 (22.10.2007) LT

(71) Applicant (for all designated States except US): UAB

"GEOLA DIGITAL" [LT/LT]; Naugarduko g. 41,
LT-03227 Vilnius (LT).

(72) Inventors; and

(75) Inventors/Applicants (for US only): ZACHAROVAS,
Stanislovas [LT/LT]; Konarskio g. 4b-13, LT-03122
Vilnius (LT). NIKOLSKIJ, Andrej [LT/LT]; Smalines

g. 23-17, LT-06225 Vilnius (LT). BAKANAS, Ramunas
[LT/LT]; L.Asanaviciutes g. 38-130, LT-04313 Vilnius
(LT). PILECKAS, Julius [LT/LT]; Gelvonu g. 4-1,
LT-07149 Vilnius (LT). GUDAITIS, Giedrius [LT/LT];
Olandu g. 55-78, LT-01207 Vilnius (LT).

(74) Agent: GERASIMOVIC, Liudmila; Vingriu g. 13-42,
LT-01141 Vilnius (LT).

(81) Designated States (unless otherwise indicated, for every
kind of national protection available): AE, AG, AL, AM,
AO, AT, AU, AZ, BA, BB, BG, BH, BR, BW, BY, BZ, CA,
CH, CN, CO, CR, CU, CZ, DE, DK, DM, DO, DZ, EC, EE,
EG, ES, FI, GB, GD, GE, GH, GM, GT, HN, HR, HU, ID,
IL, IN, IS, JP, KE, KG, KM, KN, KP, KR, KZ, LA, LC, LK,
LR, LS, LT, LU, LY, MA, MD, ME, MG, MK, MN, MW,
MX, MY, MZ, NA, NG, NI, NO, NZ, OM, PG, PH, PL, PT,
RO, RS, RU, SC, SD, SE, SG, SK, SL, SM, ST, SV, SY, TJ,
TM, TN, TR, TT, TZ, UA, UG, US, UZ, VC, VN, ZA, ZM,
ZW.

(84) Designated States (unless otherwise indicated, for every
kind of regional protection available): ARIPO (BW, GH,
GM, KE, LS, MW, MZ, NA, SD, SL, SZ, TZ, UG, ZM,

[Continued on next page]

(54) Title: METHOD FOR SPATIAL IMAGES STREAM'S OBSERVATION AND SYSTEM IMPLEMENTING THEREOF

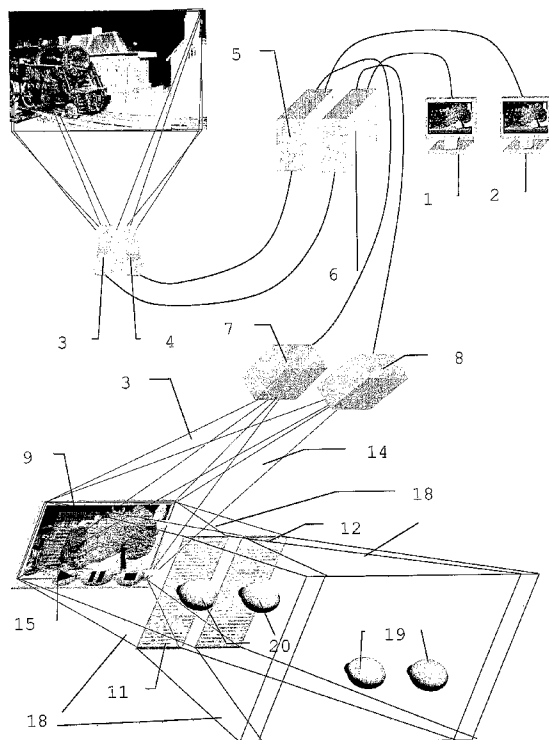

Fig. 3

(57) Abstract: This invention is related to optical systems ob-
taining autostereoscopic type effects. Proposed method for spa-
tial images and/or events observation, where stereo pairs images
stream is projected and focused onto reflection hologram, which
creates in space separate hologram surface viewing zones when
the hologram is bearing at least one flat spatial holographic im-
age part, which width is wider than human eyeball width but
narrower than an average human' interpupillary distance, said
image part being observed as appearing in front of the hologram
surface; and alongside it no other holographic image parts at
a distance less than average human' interpupillary distance are
seen. A system for the invented method implementation is de-
scribed

WO 2009/054709 A2



ZW), Eurasian (AM, AZ, BY, KG, KZ, MD, RU, TJ, TM),
European (AT, BE, BG, CH, CY, CZ, DE, DK, EE, ES, FI,
FR, GB, GR, HR, HU, IE, IS, IT, LT, LU, LV, MC, MT, NL,
NO, PL, PT, RO, SE, SI, SK, TR), OAPI (BF, BJ, CF, CG,
CI, CM, GA, GN, GQ, GW, ML, MR, NE, SN, TD, TG).

Published:

— *without international search report and to be republished
upon receipt of that report*

Declaration under Rule 4.17:

— *of inventorship (Rule 4.17(iv))*

METHOD FOR SPATIAL IMAGES STREAM'S OBSERVATION AND SYSTEM
IMPLEMENTING THEREOF

- 5 This invention is related to optical systems for obtaining of autostereoscopic type effects. More detailed, this invention relates to observation of spatial images and is designed for two stereo pair images and their stream projection towards their viewing zone applying usual holographic tools, without using any special glasses.
- 10 There are known two main methods for projected stereo pairs directing to observer's eyes – by implementing a real optical element, such as Fresnel lens, or focusing mirrors (for example, Japan patent publications JP2004226958; JP2006053321; JP2006221085 and others) or by use of holographic optical elements, which can perform same light streams directing functions. According to the common definition,
- 15 holographic optical elements are special holograms, constructed to diffract the light falling on them in some certain way. The main holographic optical elements purpose is to perform some optical functions, which is different from holograms functions, which are designed to replay three-dimensional image of the objects recorded onto hologram.
- 20 From the spatial images observation apparatuses, which use holographic optical element for directing projected image into the viewing zones, there is well known machine, described in USA patent US4799739 (1989). This machine uses two or more projectors, projecting the pair of stereo images or the stream of such pairs to
- 25 the holographic optical element, which works as a screen. This holographic optical element limits the screen viewing zones for each observer's eye in such a way that observer with each of his eyes would see the image projected by only one of the projectors. This way an illusion of spatial image is created. In the mentioned publication is also described such holographic optical element production technique.
- 30 However, the holographic optical element, described in patent US4799739 for achievement of autostereoscopic effect needs very precise projectors arrangement in space at some certain distance from holographic optical element, that is employed

as a screen. The holographic optical element features strictly define projectors lights beam divergence angle. This limits the application of such a device.

Another significant holographic optical elements employment is disclosed in USA
5 patent US 6665100 (2003). The viewing zones for observing the image are also
formed by use of holographic optical elements. As it becomes clear from the detailed
description of this invention, the size of the viewing zones is only about 3 mm. The
projectors also have to be located within space only at some certain distance from
the screen – holographic optical elements carrier, and must have strictly defined
10 angle of the light beams divergence.

An interesting recording method of the holographic optical element, which directs
two images of two stereo view pairs to their viewing zones, is described in Japan
patent publication JP2000187284 (2000). For manufacture of this screen, differently
15 than in mentioned USA patent US4799739 (1989), there are no big mirrors
employed for laser radiation focusing. Instead of that, small turning mirror used for
the object beam formation. Objective beam is formed by laser projector, which
moves in parallel to photo material. The holographic optical element is recorded on
this photo material. Unfortunately, the use of this invention is limited by necessity to
20 place the projectors in some certain distance from the carrier of the holographic
optical element and the projectors itself also must have strictly defined light beam
divergence angles.

The closest to proposed solution may be considered spatial images observation
25 apparatus according to USA patent US7027222 (2006), comprising two video
projectors, which project two images forming a stereo view. The screen consists of
mirror with the Fresnel lens placed on it. The projected images are reflected by the
mirror and are then passing through the Fresnel lens. Afterwards they are focused in
the point so that when the eye of the observer is close to this point, the screen view
30 is focused to the eye retina. In order to increase the viewing zone, patent
US7027222 offers to use diffusive light dispersion. By this dispersion, the focused
area is extended to the needed size. When the observer' eyes get to these focused
screen view areas, the observer with each of his eye sees different stereo pair image

and perceives it as a spatial image. Further in this patent there is provided a mechanism for eye tracking and changing of screen position in such a way that viewing zones formed by said screen would follow observer's position in space changes. There is also mentioned a possibility to use the holographic optical element as a screen. In this case the holographic element shall repeat Fresnel lens and mirror optical element functions. However, the focusing of the screen view on the human eye retina may be harmful to human health. Also it is quite difficult to manufacture the huge size holographic optical element performing Fresnel lens and mirror functions. Furthermore, the projectors again had to be placed at some certain distance from the screen and must have strictly defined light beam divergence angle.

Common deficiency of the above mentioned technical solutions is that they all require precise projectors arrangement in space at some certain distance from holographic optical element, which works as a screen; the divergence angle of used projectors lights beam is strictly defined by the holographic optical element features, but the distance between human eyes and screen mostly can shift only in a range of a few millimeters. Production of the large size holographic optical element is quite difficult. All these aspects limit employment of mentioned machines. That is these machines still are not widely used.

The purpose of the proposed invention is to create such optical system for the spatial image replay and observation, which would allow to employ easily manufactured large size spatial images projection screens; to use ordinary video projectors, which may have any divergence angle; to have the possibility to place these projectors in space without dependency on screen's parameters; also to simplify such systems and control mechanism for observing spatial processes.

This goal is achieved by entirety of invention features described in claims 1-19.

The main object of this invention is method for observation of spatial images stream, wherein stereo pairs image is projected at a pre-determined angle and focused onto light reflecting material which light reflecting features provide separate image viewing zone for each observer's eye in such a way that the left and the right observer's eye is consistently seeing the corresponding stereo pair' image, and the fall of the

projected light is regulated depending on the shift of observer's eye position. The method proposed in this invention differs from prior art in a way that the images of stereo pairs are projected and focused onto reflection hologram, which creates spatial separate hologram surface viewing zones, when hologram is bearing at least one flat spatial image part, characterized by the width wider than the size of human eyeball, but narrower than the average distance between human eye pupils. The image of recorded flat spatial image part is observed as situated in front of the hologram surface plane, besides there are no other image parts of spatial image visible alongside with the flat part image within the distance less than the average distance between human eye pupils. Static or dynamic stream of stereo image pairs, obtained by photographic and/or light streams having wavelengths constituents close to the wavelengths maximums of said reflection hologram reconstructed image, then project computer means.

The proposed spatial images observation method differs from any prior art in a way that continuously changing real or virtual stereo image pair stream is projected onto hologram surface in such a way that observer perceives it as a real time spatial event.

Together with the stream of stereo pairs images the virtual image of control panel is projected onto the hologram surface. This image is integrated to the image of stereo pair in such a way, that the control panel would be perceived as situated in space in front of the hologram surface plane.

Multiple independent pairs of viewing zones corresponding to the number of observers are formed in space by use of a reflection hologram, generating only one flat part of the holographic spatial image recorded thereon.

By use of reflection hologram generating multiple periodically recorded thereon flat parts of holographic spatial image it is possible to form in space a sequence of repeating pairs of viewing zones. When the observer moves from one viewing zone to the other, the stream of projected images is corrected, thus providing each observer's eye with a stream of images devoted only for that particular eye.

The observed spatial processes are controlled by observing human fingers and/or other body parts position in space changes in the area where operating panel image seen spatial image is perceived by the observer. The positions of the flat parts of

holographic image are controlled in space by changing the position of reflection hologram and/or by changing the projectors' light angles towards the hologram in such a way that said holographic image parts positions in space follows the observer's eyes position in space changes.

5

For implementation of the invention method the spatial images stream observation system is proposed, which system comprises spatial image directional reflection tool (the screen), projectors for projecting of light or images to the spatial image directional reflection tool, means for tracking the position of observers eyes and/or movements other body parts, controllers of projectors light beams and controllers of position of spatial image directional reflection tool in space, wherein the spatial image directional reflection tool is in optical connection with projectors, allowing to form in space the viewing zones of directional reflection tool, intended for the different observer's eyes, the right and the left correspondingly. By watching through said zones, the observer perceives image, projected by two projectors to the directional image reflection tool, as a spatial image.

The proposed system differs from a prior art in a way that the directional reflection tool comprises as the screen the reflection hologram bearing at least one holographic image part recorded, which image is seen as situated in front of the hologram surface, the image width being wider than the size of human eyeball, but narrower than the average distance between human eye pupils, besides there are no other images of spatial holographic images parts visible at a distance less than an average distance between human eye pupils. This system is also different by additionally comprising stream source of the stereo image pairs, translating the images stream to the projectors through the stereo pairs image-processing unit.

Stereo image pairs stream source has possible option to integrate the image of real and/or virtual object and/or the sequence of passing stereo pairs images into the stream of spatial images, projected by projectors onto the surface of hologram. The stereo pairs image processing unit comprises means to digitally define how each part of integrated stream of stereo images will be perceived by the observer – in front, behind or on the surface of hologram.

Using more than one pair of video projectors and employing corresponding number of stereo video cameras or video camera pairs as the source of stereo pairs images stream, extends the system possibilities. One computer having several video outputs or corresponding number of computer pairs can be employed in stereo image pairs processing unit. The projected light beams are controlled by the controllers of projectors lights beams, reacting to the shift of observers eyes position in space and redirect the said light beams angles towards the hologram in such a way that holographic image parts positions in space follows the observer's eyes position in space changes. Changing the position of reflection hologram in regard to the video projectors controls the positions where stripes images recorded in the hologram appear in space.

The proposed method and its implementing system are illustrated by the drawings, in which:

- 15 Fig. 1a shows how the spatial holographic image's part is reconstructed in space when hologram is illuminated by one directional point light source;
- Fig. 1b shows how the spatial holographic image's part is reconstructed in space when hologram is illuminated by two directional point light sources (view from the top, each eye sees the hologram illuminated by different light source);
- 20 Fig 2 shows the principle schema of the spatial images stream observation method proposed in the invention;
- Fig 3 shows the schematics of the spatial images stream observation system proposed in the invention (implementation example 1);
- Fig. 4 shows the block scheme of proposed spatial images stream observation system, intended for one observer;
- 25 Fig. 5 shows the block scheme of proposed spatial images stream observation system, intended for three observers (spectators);
- Fig. 6a shows the block scheme of proposed spatial images stream observation system, intended for one observer (spectator), when there are several identical parts of spatial holographic image, creating the sequence of viewing zones in space, recorded in hologram;
- 30 Fig. 6b shows the block scheme of proposed spatial images stream observation system, intended for one observer (spectator), when there are several identical parts

of spatial holographic image, creating the sequence of viewing zones in space, recorded in hologram. The observer has changed his eyes position according to the screen and the streams projected by the projectors is switchable in the way that each eye (left and right) would further see only the image intended for it.

5

For the detailed invention description it is important that the main tool for the technical task solution, which allows reaching invention goals, is use of a particular reflection hologram as a screen for spatial images stream observation.

10 Main difference between holograms and holographic optical elements (which employment for spatial images observation is mentioned in a few patents) is that holograms usually are recorded by employing parallel beams of coherent light. Because of that, when holograms are lighted with the point light source (Fig. 1a, 1b), placed at the distance at least 1,5-2 times bigger than the diagonal of lighted hologram, the position of spatial holographic image in space and it's other features
15 do not, or almost do not, change and do not depend on employed light source light's divergence.

According to this invention the most appropriate is the reflection hologram, bearing at least one flat part of the spatial holographic image, the width of which is wider
20 than the size of human eyeball, but narrower than the average distance between human eye pupils. This part of the holographic image has to be seen as situated in space in front of the hologram surface at a distance, corresponding to the comfortable distance, recommended in the ergonomic standards of the images observation machines (at least 30 cm, depending on screen size). Also this part of
25 the holographic image has to be seen at the distance that is bigger than the average distance between the human eye pupils from the other parts of spatial holographic image. The mentioned reflection hologram can be produced by usual analogue reflection holograms production methods, as well as printed by digital holographic printers. Contact or non-contact copies of such holograms can also be employed. As
30 an example of the flat part of the spatial holographic image can be employed a vertical stripe, the plane of which is parallel to the hologram surface plane and which corresponds to the mentioned conditions of it's width and distance to the other parts of spatial holographic image.

When hologram, which is bearing the information about the position of mentioned holographic image in space, is lighted with the directional point light source, this light is diverted by hologram to some special place in space, where the luminous holographic image is formed (Fig. 1a).

- 5 If the observer is placed in position where his eye would get very close or exactly to the same place, where the mentioned flat part of the spatial holographic image formed by the hologram appears, he would see the whole hologram surface, which diverts the light of directional point light source for said image part formation. Viewer will see the hologram surface as a bright and shining extended light source.
- 10 If the directional point light source's light falling to the hologram vector projection to the plane of the hologram surface is not parallel with the images recorded on the hologram vertical direction, then the part of the image's position shifts from the normal to the hologram surface plane, together with whole spatial holographic image. So, when lighting the hologram with two directional spot light sources, there
- 15 are formed two spatial holographic images (Fig. 1b). The position between these images vis-à-vis can be adjusted by changing distance between the point light sources.

- If the size of each flat part of such spatial holographic image corresponds to the
- 20 condition that it is smaller than the distance between human eye pupils, but bigger than the size of human eye-ball (besides, there are no other image parts at a distance which is less than an average distance between human eye pupils), the distance between directional point light sources has to be picked up in such a way, that the hologram area illuminated by each of it would be seen only with one or only
- 25 with another eye at the same time, when the eyes of the observer are placed close to the areas where two images of holographic image parts are formed in space.

- In this invention, for holographic image reconstruction, instead of directional point light sources are employed video projectors (Fig. 2). These projectors project static
- 30 or dynamic stereo pairs image, obtained by photographic or computer means.

Then directional point light sources are replaced by video projectors, which project stereo pairs image or streams of such video image pairs and focus image (images

stream), projected by them on the hologram surface. When observer' eyes are close to these zones, where two images of above mentioned spatial holographic images' parts are formed, these image parts work as the viewing zones of hologram surface illuminated by projectors. This way, each eye will see only one devoted for it stereo pair image (Fig. 2 and other) and observer will perceive seeing image as spatial.

For the economic enhancement of the light used in the projectors, as sources of light can be employed light diodes or diode lasers, which have the wavelengths suitable for holographic image reconstruction.

10

One or several projector pairs are arranged in space in such a way, that stereo pairs image light (projected and focused on reflection hologram surface) would create volatile sequence of non-intersecting viewing zones pairs.

When several projectors or several projector pairs are employed for illuminating the hologram, bearing the mentioned part of the image recorded, several hologram surface-viewing zones will be formed (Fig. 5). If on the hologram employed a sequence of mentioned parts of the special holographic image is recorded, then the corresponding sequence of viewing zones will be formed in space.

20 If the projected stream of stereo pairs images is obtained from two video cameras positioned in some certain distance between each other, it opens a possibility to observe spatial processes in real time.

One or several stereo pairs image stream sources (Fig. 5) can be selected from a group, comprising of stereo video camera; identical video camera's pairs, having a certain distance between the centers of their objective-lenses; three-dimensional video games stereo image streams; three-dimensional video films stereo image streams; educational content video stereo pairs image streams; stereo image pairs stream, obtained after processing of two-dimensional images streams, including static streams; or of combinations of mentioned or similar nature sources of stereo image pairs streams.

30

Besides stereo image stream obtained from two video cameras or by employing other passing stereo image pair streams (movies, video games, etc.) processed by

computer means, it is also possible to integrate into projecting streams a virtual image of control panel in such a way, that this control panel would be recognized by the observer as positioned in space in front of the hologram surface (Fig. 3). Human interaction with virtual control panel can be realized by employment of usual methods of tracking the movements of human hands or other body parts.

System further comprises controllers, reacting to the changes of position of observer's eyes and/or other body parts.

The position of hologram image in space (except of it's distance from the hologram surface) can be adjusted by changing the position of the directional point light sources or position of hologram itself. Therefore, by applying usual human eyes tracking methods and lights streams or hologram position controllers, it can be ensured that the position of viewing zones would follow the changes of human eyes position in space.

In case of need to have a possibility to use the same holographic screen for a few spectators for watching the same or different spatial images, this possibility can be implemented by increasing the number of projector pairs and human eyes and hands tracking devices, as well as the number of projectors' light streams controllers. For example, the mere device, intended for three spectators (Fig. 3) shall have three stereo image pairs projection sources (six separate projectors or three projectors with two video light outputs), three human eye position tracking devices, three sets of projector light beams controllers. Also such device may have one or several sources of stereo pairs image.

If the screen is designated for one human use, other method can be applied for extending stereo image viewing zone in horizontal direction (Fig. 6a). Then the hologram with several identical holographic images recorded is used. These holographic images must be recorded to be seen in space as images parallel to the hologram surface plane and their planes would be parallel to the plane of hologram surface and situated at a distance from hologram surface that is comfortable and recommended in the ergonomic standards of the images observation apparatus (not less than 30 cm). The width of each holographic image part must be narrower than

the distance between human eye pupils, but wider than human eyeball size. The distance between these parts must be equal to an average distance between human eye pupils. For example, the hologram of fence, constructed of even planks with the even distance between these planks. When illuminating such hologram with two projectors, twice more views of the images recorded on the hologram will appear in space. The projectors are to be arranged in such a way, that the mentioned holographic images would create in space the sequence of replicated viewing zones pairs.

10 When human head moves in horizontal direction, the stereo pair image devoted for left eye can become seen by the right eye (Fig. 6b). At this moment, the controller, which reacts to the human eye position changes and controls projector light beams is switching the projected views streams so, that the left and the right eyes are always seeing the stereo pair image devoted for particular eye.

15

For implementation of the invented method, the spatial images stream observation system is proposed (Fig. 2, Fig. 3 and others), which has the spatial view directional reflection device (the device for targeting the projected view to its seeing zones) and comprises of the source 3,4 of stereo pairs images 1,2 connected with the images stereo pairs processing unit 5,6, which has one or a few pairs of video projectors 7,8 connected to it (Fig. 2 – Fig. 6b).

20

For directing of the projected view to its seeing zones, the system has employed a reflection hologram 9 or its contact or non-contact copy.

25

Reflection hologram 9 is bearing one or more vertical stripes 10 (Fig. 4) recorded in it. The planes of these stripes images 11 (or K) and 12 (or D) are parallel to the hologram surface plane. Strips widths are wider than human eyeball, but narrower than the distance between observer's eyes. Furthermore, there are no other parts of spatial images at a distance, less than the average distance between human eye pupils. The mentioned stripe is recorded so that their images 11 (K) and 12 (D) would be recognized by observer as floating in space at a distance not less than in 30 centimeters in front of the hologram surface.

30

The pair of projectors 7,8 is arranged in space in such a way, that stripe 10 images 11 (K) or 12(D) arisen by the light of images projected and focused on the hologram 9 surface by video projectors, would not overlap and would form viewing zones of the images focused on the hologram 9 surface; and the images, projected by
5 projectors 7,8 would be correspondingly seen by the left or right observer' eye.

The image processing unit 5,6 has computing tools, which allow to combine the stereo image pairs of real and/or virtual object with the passing sequence of the stereo image pairs, translated by the source 3, 4 (stereo video film, game,
10 educational material and similar), this way obtaining the integrated stream of stereo image pairs 1, 2 (Fig. 3), which is further projected to the hologram surface by projectors 7, 8.

As unit 5, 6 for stereo image pairs processing can be employed one computer with a few video outputs or corresponding number of computer pairs connected; personal
15 or specialized computer can be used for this task.

The system is provided with controllers (not represented on drawings) to control light beams 13, 14 that carry the stereo image pair stream 1, 2 and to control of integrated content of the said stream. These controllers are reacting to the changes
20 of position of observer's eyes or other body parts.

Projectors 7, 8 can project various streams of stereo pairs images, including stereo games and movies. Observer will perceive his seeing as moving spatial images. It is foreseen that besides the obligatory pair 7, 8 of projectors, there can be arranged
25 additional pairs of projectors (Fig. 5) so that the holographic images would create passing sequence of viewing zones pairs K, D.

The possibility to use not only a few video projectors 7,8, but also the corresponding number of video cameras 3,4 pairs, or stereo cameras, or other sources of stereo image pairs stream (Internet, TV, etc.) is foreseen.
30

For the economic enhancement of projectors 7,8, as sources of light the light diodes or diode lasers may be employed. Said light sources shall have the radiation

wavelengths suitable for holographic image reconstruction. Video projectors may have one common light source.

The whole system's control panel image (Fig. 15) is integrated into the projected stream of stereo images by the computer aids 5,6 in such a way, that observer would perceive it as situated in space in front of the hologram 9 surface plane. Usual human movements tracking means are employed for the control of this virtual panel.

The system of spatial images observation and the proposed method are realized this way:

The reflection hologram 9 is chosen. In the holographic spatial image of this hologram there must be at least one flat part 10 of spatial holographic image, that is perceived as situated in space in front of the hologram surface at a distance corresponding to comfortable viewing distance recommended in the ergonomic standards for images observation apparatus (not less than 30 cm) and this image part 10 appears at a distance from other spatial holographic image parts which is bigger than the average distance between human eye pupils. Moreover, the width of such holographic image part must be wider than the size of human eyeball, but narrower than the average distance between human eyes. Image of a stripe, which is seen as situated in space in front of the hologram 9 surface and parallel to the hologram 9 surface, may be employed as such flat part of holographic image.

Two video projectors 7 and 8, bearing in the radiated light stream the wavelengths constituents corresponding to the maximums of used hologram reconstructed holographic image wavelengths, are arranged in space so that the projected light beams would fall onto the hologram 9 in directions, corresponding to the direction of directional point light, needed for holographic image reconstruction in such a way that the holographic image parts 11 (or K) and 12 (or D) would be seen as situated in the center of hologram 9, for example, approximately in 1 cm distance between each other. The distance between the projectors 7,8 and hologram 9 is chosen such that projectors would illuminate the whole hologram 9 surfaces, which directs projectors 7,8 lights to form holographic image parts 11 and 12. The projected images are focused on the hologram 9 surfaces.

The pair of video cameras 3,4 or one stereo camera translates the stream of stereo images pairs. Real-life or any other stream of stereo image pairs, such as 3D video games, 3D video films, 3D educational programs or 3D simulators can be translated to image projectors 7,8.

5

This stream of stereo pairs images is processed by computer means 5,6 of processing unit. The unit can also employ one computer with a few video outputs. Unit is performing geometric corrections of image streams, which are needed for compensation of projected images geometric distortions; as well it regulates colour balance of projecting images. With the help of computers a control panel image is integrated into each stereo pair image in such a manner, that the panel would be perceived as floating in the space in front of the hologram 9 surfaces. During the images integration process it is defined how each of the integrated images will be perceived by observer – i.e. the position of each integrated stereo image in space in regards with the hologram surface. If the image of stereo pair, intended for the left eye is projected to the plane of hologram surface in such a way that it is situated from the right side of the image devoted for the right eye – then the spatial view is perceived as situated in front of the plane of hologram surface. If the according stereo pair images are projected conversely – spatial image is recognized as situated behind hologram surface plane. In case the images, intended for the both eyes coincide on the plane of hologram surface – then observed view is recognized as flat view on the hologram surface. So, applying mathematical calculations and geometrical transformations to stereo pair images, it becomes possible to control the perception of spatial image position in regard to the hologram surface.

10
15
20
25

By common tracking means of human body parts movements (not presented on the drawings) position of human fingers or other body parts in space in regard to the mentioned control panel image 15 is registered, as well as changes of this position. For of spatial images observer this gives a possibility to control the observation system itself, as well as the remotely observed processes. Such control is performed by processing change of human fingers or other body parts position in regard to the mentioned control panel image 15 and transmitting corresponding control signals to

30

computer means 5,6 or to remote controllers, which control the observed spatial processes.

When the position of human eyes shifts off the positions of the holographic image parts 11 and 12, the directions of projector light streams and/or hologram 9 position in space are correspondingly modified so, that the positions of human eyes and holographic image parts 11 and 12 would always coincide. This way, the positions of the of the images of holographic image parts 11 (K) and 12 (D) are controlled by changing the angle of projected light beams 13,14 to the hologram surface and/or the position of reflection hologram in regard to the video projectors 7,8.

The operation of this system and the possibility of the proposed method implementation are explained by the examples, which are presented for the purpose of illustration and in any way do not restrict the scope of invention.

15

Example 1 of the invention implementation.

For simplicity it is confined with only one pair of video cameras with one image processing unit consisting of two personal computers and reflection hologram with dimensions 50 cm (horizontal) x 37 cm (vertical).

Hologram 9 (Fig. 3, Fig. 4) had one part of spatial image, reconstructed ahead the plane of hologram surface at the distance, corresponding to the comfortable distance, recommended in the ergonomic standards of the images observation machines (not less than 30 cm). In this example, the hologram, printed by technology created by UAB "Geola Digital" (Vilnius, LT, Lithuanian patent LT4842) was used, bearing only one stripe recorded on this hologram. The image of this stripe reconstructed at 1m distance from the hologram surface.

The necessary conditions for the observation of spatial image are mentioned above: it is obligatory that the width of the flat image part - recorded stripe appearance in space would be not narrower than the width of human eyeball and not wider than the distance between human eye pupils, and it is necessary, that no other parts of the same holographic image would appear alongside with the used part of the image 11 (or 12) within the distance less than distance between human eye pupils.

Hologram 9 is illuminated by directional point light source 16 light beams 13, falling to the hologram at such an angle, that part of the hologram image 10, formed by hologram directed light beam 18 and observed by human, who's eyes are in position 19, would be clearly seen in space in front of the hologram surface (like in Fig. 1). In this case, the position 19 is defined as observer's position in space in front of the hologram 9, within hologram's viewing zone and at a distance that is not less than 3 meters from the hologram surface plane.

When observer's eyes are in position 20 or close to this position, i.e. observer's eyes are in the position where image 11 of the holographic image part is formed, only one of his eyes, directed to the hologram surface has to see all the hologram surface, which is illuminated by the directional point light source 16 and directing this light for the formation of image part 11 in space (Fig. 1 a). The second directional point light source 17 is placed in space alongside the source 16 and the source 17 is shifted in horizontal direction so, that the light beam 14 of the light source 17, falling onto the hologram and correspondingly redirected by it, would form in space one more image of the same spatial holographic image part 12 (or D), positioned alongside the image part 11(K) at such a distance that when the both parts of the image (11 and 12) are observed by human, whose eyes are in position 19, they would be clearly seen in space alongside each other (like in Fig. 1b).

When observer's eyes are in position 20, one his eye sees all the hologram surface illuminated by the directional point light source 16 – hologram is redirecting this light for the holographic image part 11 (K) formation (Fig. 1 a); and the other eye will see all the hologram surface illuminated by the directional point light source 17 – hologram is redirecting this light for the holographic image part 12 (D) formation (like in Fig. 1b).

Then directional point light sources 16 and 17 are replaced by video projectors 7 and 8 (Fig. 2 and others).

Common, home-use or professional video projectors 7, 8 are arranged in space in such a way, that the light beams 13,14 projected by them (Fig. 2, Fig. 3) would fall onto the hologram 9 in directions, which coincide the directions of directional point

light source 16,17 (Fig. 1b), needed for reconstruction of holographic image recorded in the hologram.

Image projected by video projectors 7 and 8 is focused on the surface of hologram 9.

5 Since the projectors 7,8 are placed in space with some certain distance between them – two images of the stripe recorded in the hologram are formed in space (11 or D and 12 or K, Fig. 2 – Fig. 6a). When the observer is in position where his eyes get close to the zones in space where the holographic images K and D of the stripe are formed, each eye sees the image projected onto hologram surface by different
10 projector.

This way, the observer, whose eyes are in position 20, watching through the parts of holographic image 11 (K) and 12 (D), with one of his eyes on the hologram 9 surface is seeing the image, projected by the projector 7 and with the other eye - the image projected by the projector 8.

15 When projectors 7 and 8 onto hologram surface plane 9 are projecting static images, belonging to one of stereo images pair, the observer, whose eyes are in position 20 (Fig. 2, Fig. 3), will perceive the observed image as spatial.

Image stream, obtained from the video stream sources 3,4 is translated to projectors 7,8 through stereo images pairs processing unit 5,6. By projecting passing sequence
20 of stereo image pairs (video films, video games, educational stereo programs, remote observation stereo cameras), the observed view will be perceived as moving spatial view.

In this example, the image streams of moving toy train, focused by projectors on the
25 hologram surface plane 9, were translated from two video cameras 3,4 (Fig. 3), positioned in space at ~64mm distance between the centers of their objective-lenses, i.e. were translated like different images of one stereo pair, each of which image to be seeing with different eye. The observer perceives the observed view (as a whole) as three-dimensional moving spatial view. A stereo image pair of static
30 image of a tree has been integrated to the image stream of moving toy train by the computer 5,6 means so that it would look as if the train drives behind the tree.

With the computer means of video processing unit 5,6 the image of the whole device control panel has been integrated to the stream of projected stereo images so that this image of control panel 15 looked as if hanging in space in front of the hologram 9 surfaces.

- 5 The control of virtual control panel was performed by employing usual human fingers movement-tracking tools and simulating the pressing of keys "forward", "play", "stop".

Registering human movements in space in the environment of apparent control panel image 15 with assistance of usual means it is possible to control the whole or
10 parts of the system's operation or other observed spatial processes.

Projectors light beams 13, 14, illuminating the hologram 9, were consistently directed onto the hologram so that the position of holographic image parts 11,12 formed by hologram would coincide the position of human eyes in regard to the hologram.

15

Holographic image part (stripe) position in space has been adjusted by changing position of reflection hologram 9 in regard to video projectors 7,8.

Tracking of human eyes position and directing of projector lights in proper directions was performed by usual human eye tracking control means and according to
20 projector light beams control methods, i.e. by adjusting the projector 7 and 8 light beams fall onto the hologram surface so that the position of the parts 11 (K) and 12 (D) of the holographic image in space would coincide the shifted position of human eyes.

25 Example 2 of the invention implementation.

The observation of spatial images stream and the system employed for it were basically corresponding the ones described in example 1. The difference is that the pair of video cameras 3,4 was directed to the real-life scene.

Digital signal of each video camera was converted to video signal by computers 5,6
30 that belong to the video processing unit (or using one computer with a few video outputs), performing the geometric corrections to the stream's images. These corrections are necessary for the compensation of the projected images geometric view distortions and for the color balance control.

These computers also performed the geometric correction of the images so that when projecting these images to the hologram surface plane 9 by projectors 7,8, video proportions would coincide the real-life scene proportions. The image of device's control panel 15 was integrated into the stream of stereo image pairs of the real-life scene also with the help of said computers.

Projected by the projectors images of real life scene and the image of control panel were monitored by the help of two monitors 1,2.

The positions of human fingers in space regarding the control panel have been observed and tracked by usual motion tracking tools by assigning some certain operation to each human fingers position in regard to the device itself or in regard to the observed scene.

The position of the spectator's eyes in space was also watched: when the eyes position switched from the holographic image parts 11 (K) or (D) positions in space, the directions of projector light streams and/or the position of hologram 9 have been accordingly modified in such manner, that the positions of human eyes and the holographic image parts 11 (K) or (D) would always coincide.

Besides the real-life images, the projectors can also project any other stream of stereo images pairs, for example, 3D video games, 3D video films, 3D educational programs, the images of 3D simulators or various combinations thereof.

As it might be seen from the given description, drawings and examples, the completeness of all the features indicated in the invention claims allowed to create optical system for the spatial image reconstruction and the spatial images stream observation, which can employ easily manufactured large size screens for the spatial images projection; to use usual video projectors, which may have any light divergence angle, and which can be positioned in space at a distance, which is not dependant on the screen features, and also to simplify the control of such systems and the spatial processes evoked by them.

Claims:

1. Method for spatial image stream observation, wherein stereo images are projected at a pre-determined angle and focused onto the light reflecting material, which light reflecting features provide separate image viewing zone for each observer's eye in such a way that the left and the right observer's eye is consistently seeing the corresponding stereo pair' image, and the fall of the projected light is regulated depending on the shift of observer's eye position, **characterized in that** the images of stereo pairs are projected and focused onto reflection hologram which creates spatial separate hologram surface viewing zones, when hologram is bearing at least one flat spatial image part, characterized by the width wider than the size of human eyeball, but narrower than the average distance between human eye pupils, and the image of which is observed as situated in front of the hologram surface plane, besides there are no other image parts of spatial image visible alongside with the flat part image within the distance less than the average distance between human eye pupils, and the images of stereo pairs are projected by beams of light, which wavelengths constituents are close to the light wavelengths maximums of said reflection hologram reconstructed image.
2. Method according to claim 1, **characterized in that** projected image is static or dynamic image of stereo pair, obtained by photographic or computer means.
3. Method according to claim 1 or 2, **characterized in that** additional stereo pairs images of real and/or virtual objects and/or the combinations thereof and/or the stream of passing stereo pairs images are projected onto the surface of the hologram in such a way that the observer would perceive it as the events of the real time spatial process.
4. Method according to any of the previous claims, **characterized in that** together with the stream of stereo pairs images the virtual image of control panel is projected onto the hologram surface, being integrated to the image of stereo pair in such a way, that the control panel would be perceived as situated in space in front of the hologram surface plane.

5 5. Method according to any of the previous claims, **characterized in that** multiple independent pairs of viewing zones corresponding to the number of observers are formed in space by use of reflection hologram, generating only one flat part of the holographic spatial image recorded thereon.

10 6. Method according to any of claims 1-4, **characterized in that** sequence of repeating pairs of viewing zones are formed in space by use of reflection hologram generating multiple periodically recorded thereon flat parts of holographic spatial image, and when the eyes of the observer are getting from one viewing zone to the other, the stream of projected images is corrected, providing each observer's eye would further see the stream of images that is devoted only for particular eye.

15 7. Method according to any of the previous claims, **characterized in that** the observed events of spatial process are controlled by employing tracking means for observing the position of human fingers and/or other body parts in space regarding to the control panel image.

20 8. Method, according any of the previous claims, **characterized in that** the positions of the flat parts of holographic image are controlled in space by changing the position of reflection hologram and/or by changing the projectors' light angles towards the hologram in such a way that said holographic image parts positions in space follows the observer's eyes position in space changes.

25 9. System for observation of spatial images stream, comprising:
- spatial image directional reflection tool;
- projectors for projecting of light or images to the spatial image directional reflection tool;
- means for tracking the position of observers eyes and/or movements other body
30 parts;
- controllers of projectors light beams and controllers of position of spatial image directional reflection tool in space;

wherein the spatial image directional reflection tool is in optical connection with projectors, allowing to form in space the viewing zones of directional reflection tool, intended for the different observer's eyes, the right and the left correspondingly, **characterized in that** the directional reflection tool comprises the reflection
5 hologram (9) bearing at least one holographic image part recorded, which image (11,12) is seen as situated in front of the hologram (9) surface, being wider than the size of human eyeball, but narrower than the average distance between human eye pupils, besides there are no other images of spatial holographic images parts visible at a distance less than an average distance between human eye pupils, the system
10 additionally comprising the stereo image pairs (1,2) stream source (3,4), translating the images stream to the projectors (7,8) through the stereo pairs image processing unit(s) (5,6).

10. System according to claim 9, **characterized in that** the source of stereo
15 pairs images stream (3,4) is provided with possibility to integrate the image of real and/or virtual object (15) and/or the sequence of passing stereo pairs images into the stream of spatial images, projected by projectors (7,8) onto the surface of hologram (9).

20 11. System according to 9 or 10 claim, **characterized in that** the stereo pairs image processing unit (5,6) comprises means to digitally define how each part of integrated stream of stereo images will be perceived by the observer – in front, behind or on the surface of hologram (9).

25 12. System according to any of 9-11 claims, **characterized in that** the spatial images directional reflection tool comprises contact or non-contact copy of corresponding hologram.

30 13. System according any of 9-12 claims, **characterized in that** more than one pair of video projectors (7,8) is used, and corresponding number of stereo video cameras or video cameras pairs are used as the source of stereo pairs image stream (3,4).

14. System according to any of 9-13 claims, **characterized in that** the source of stereo pairs images stream (3,4) is selected from the group, comprising of stereo video camera; identical video cameras pairs; three dimensional video games images streams; three dimensional video films images streams; three dimensional educational programs images streams; streams of images pairs, obtained by two-dimensional images streams processing, including static images; or from the composition of the mentioned or similar stereo pairs image streams.

15. System according to any of 9-14 claims, **characterized in that** the stereo pairs images processing unit (5,6) comprises of one computer with a few video outputs, or the corresponding number of computer pairs.

16. System according to any of 9-15 claims, **characterized in that** the controllers of projectors lights beams (13,14) are reacting to the shift of observers eyes position in space and redirect the said light beams angles towards the hologram in such a way that holographic image parts positions in space follows the observer's eyes position in space changes.

17. System according to any of 9-16 claims, **characterized in that** the video projectors (7,8) used optionally have one common source of light.

18. System according to any of 9-17 claims, **characterized in that** the positions of the recorded on the hologram stripes images (11,12) are controlled by changing the position of reflection hologram (9) in regard to the video projectors (7,8).

19. Use of reflection hologram with at least one stripe recorded on it, which image, observed as situated in front of the hologram, is characterized by the width wider than the size of human eyeball, but narrower than the average distance between the human eye pupils, and there are no other image parts of spatial image visible within the distance less than the average distance between human eye pupils, for the method for observation of spatial images stream according to claims 1-8.

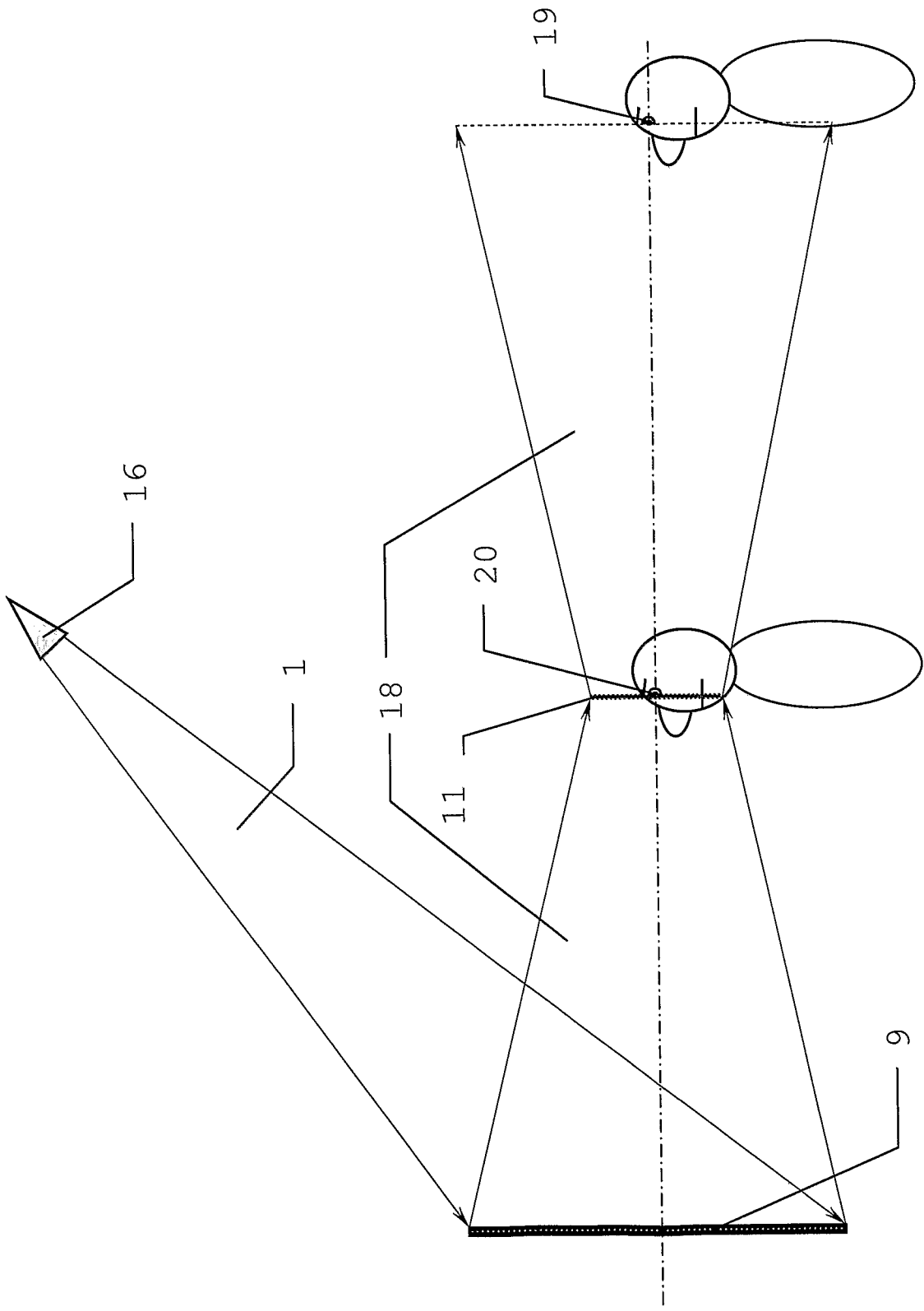

Fig. 1a

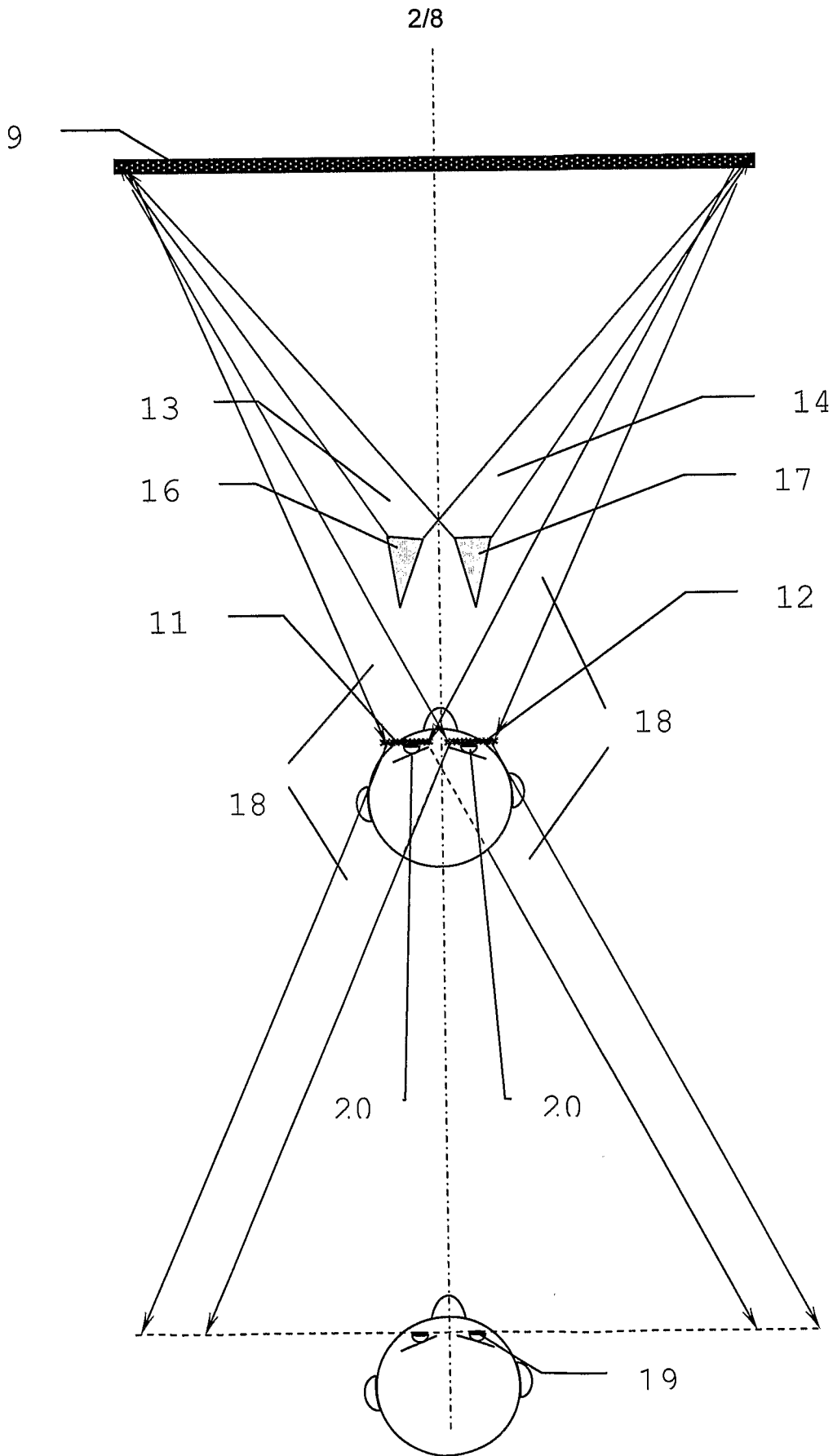

Fig. 1b

3/8

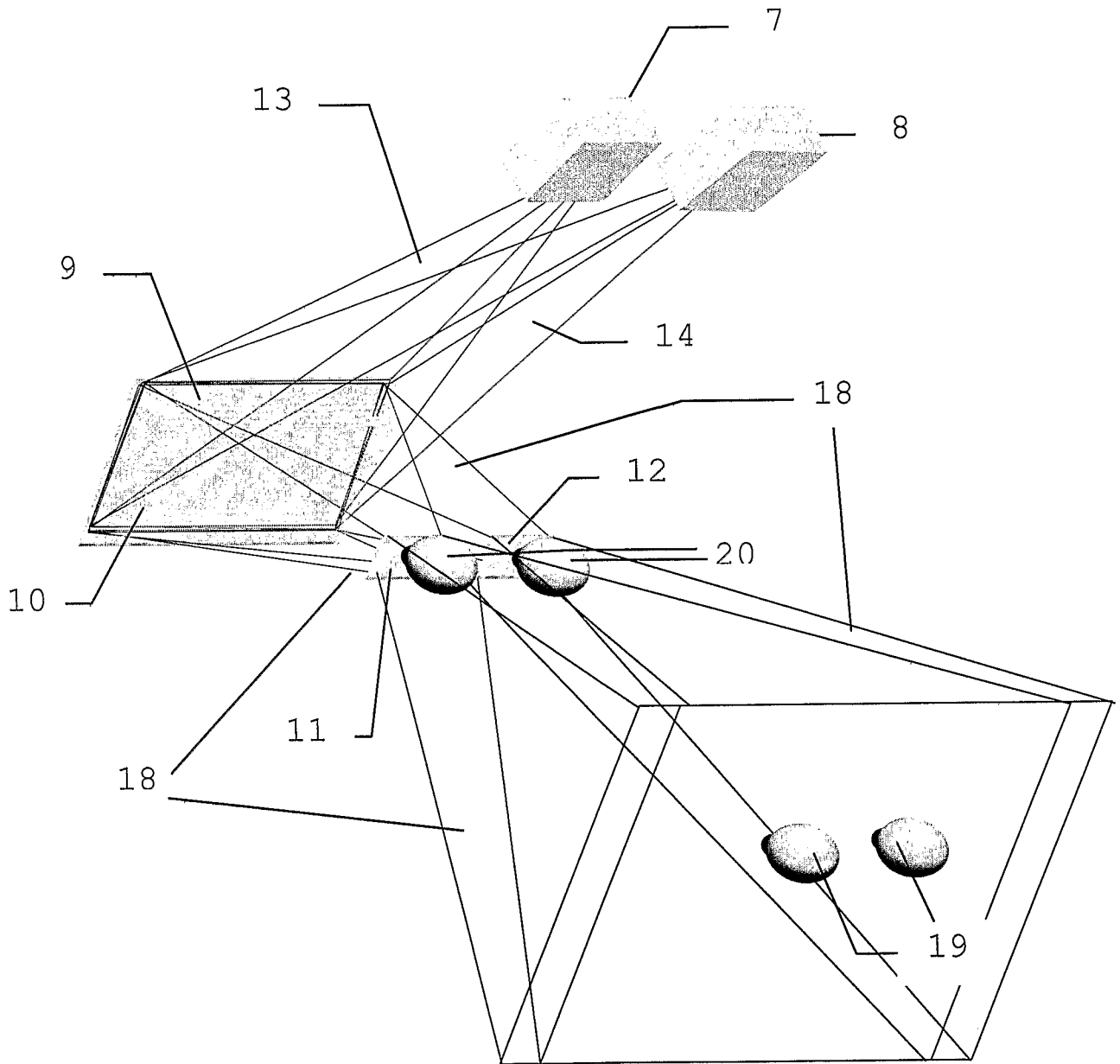

Fig.2

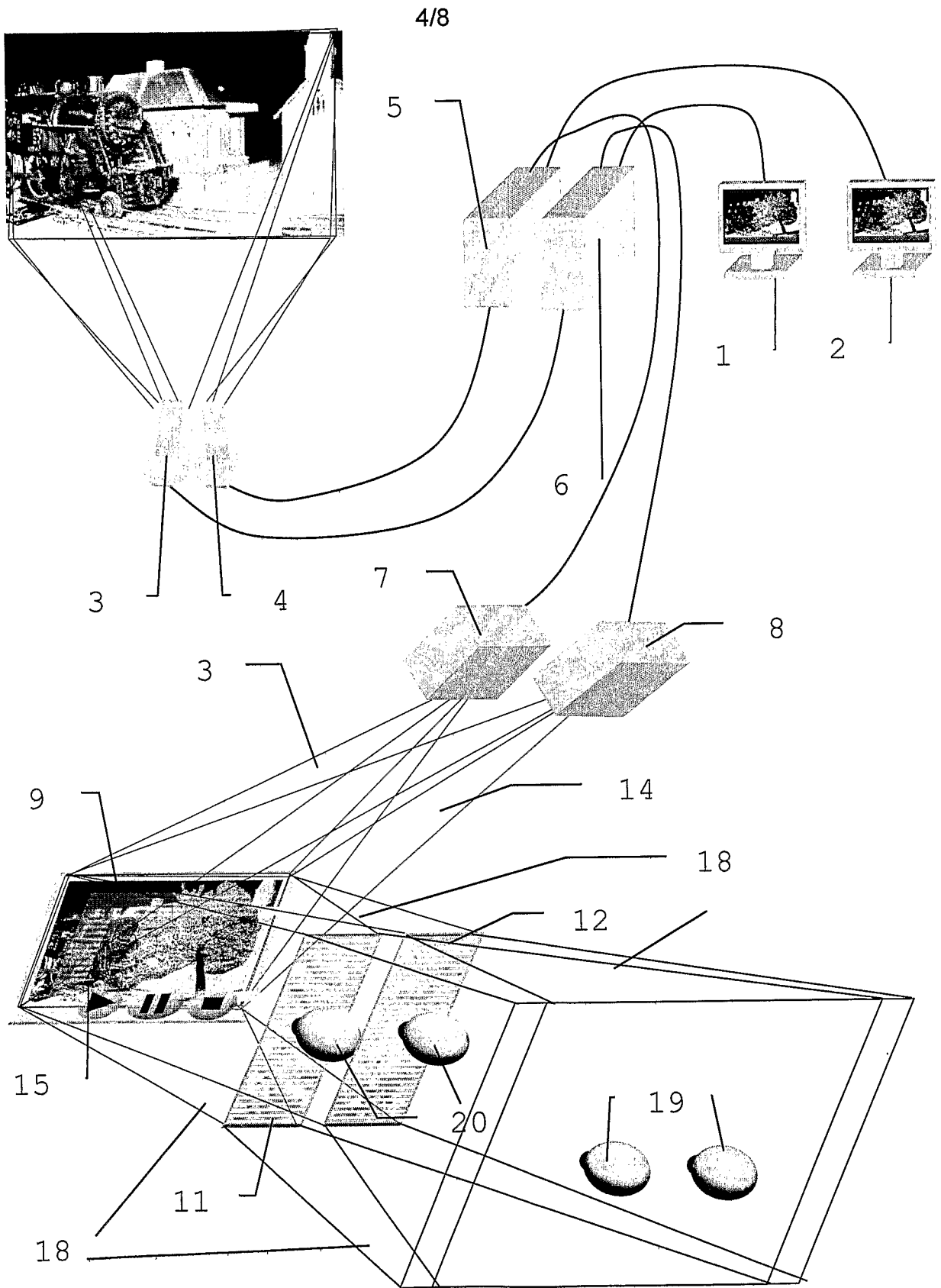

Fig. 3

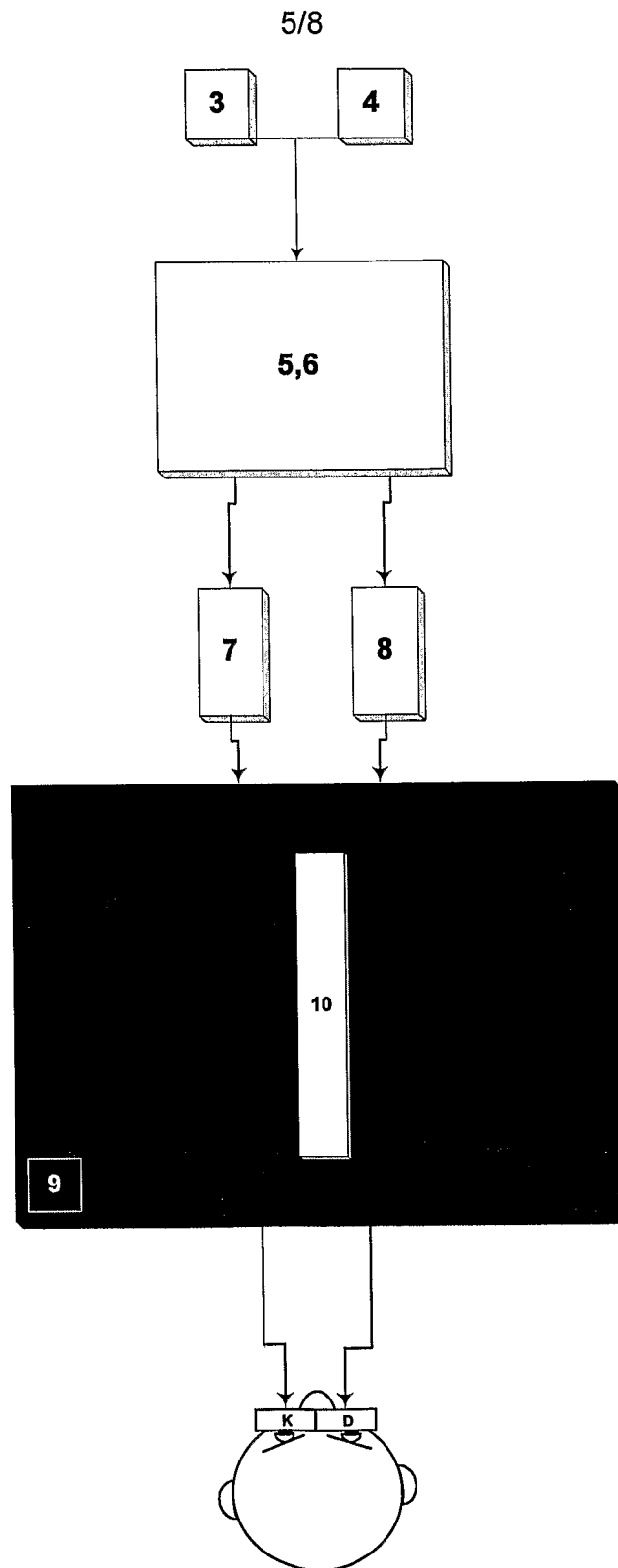

Fig. 4b

6/8

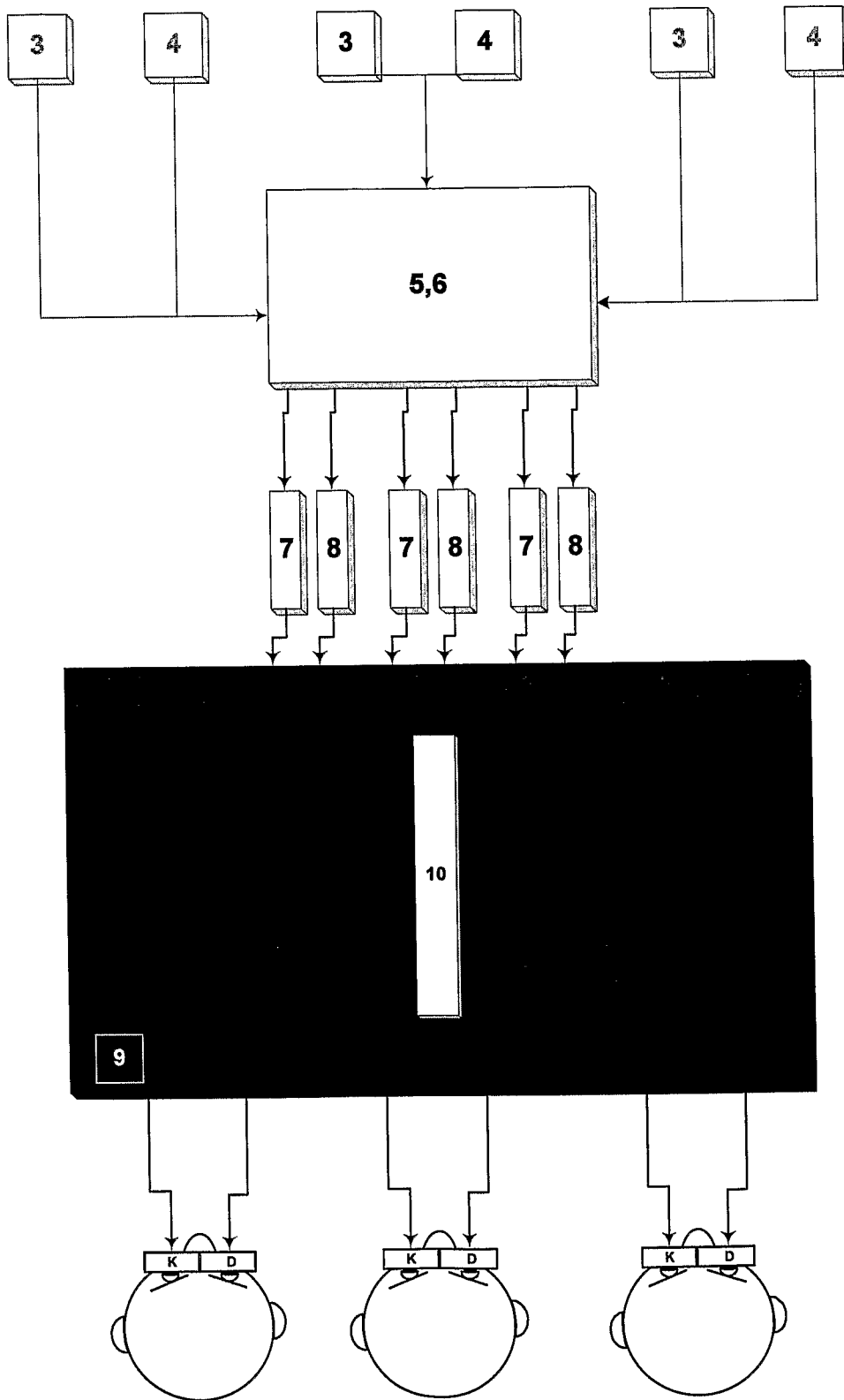

Fig.5

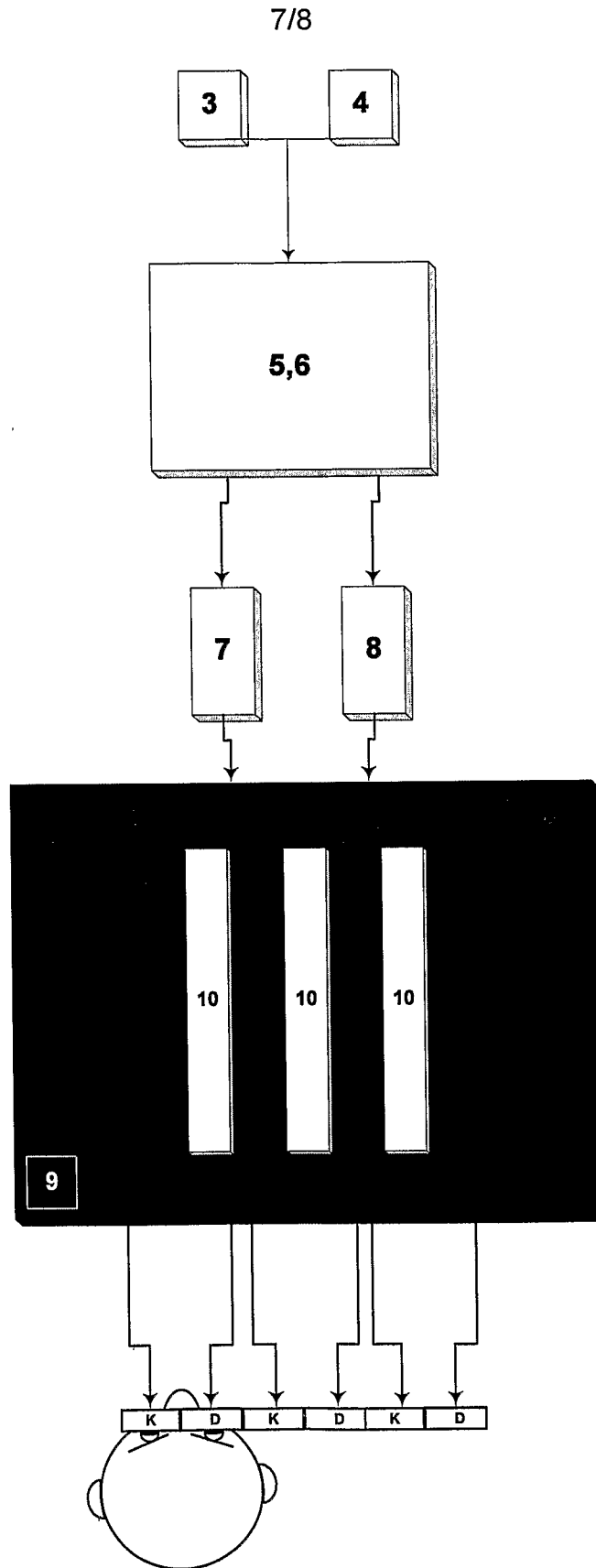

Fig. 6a

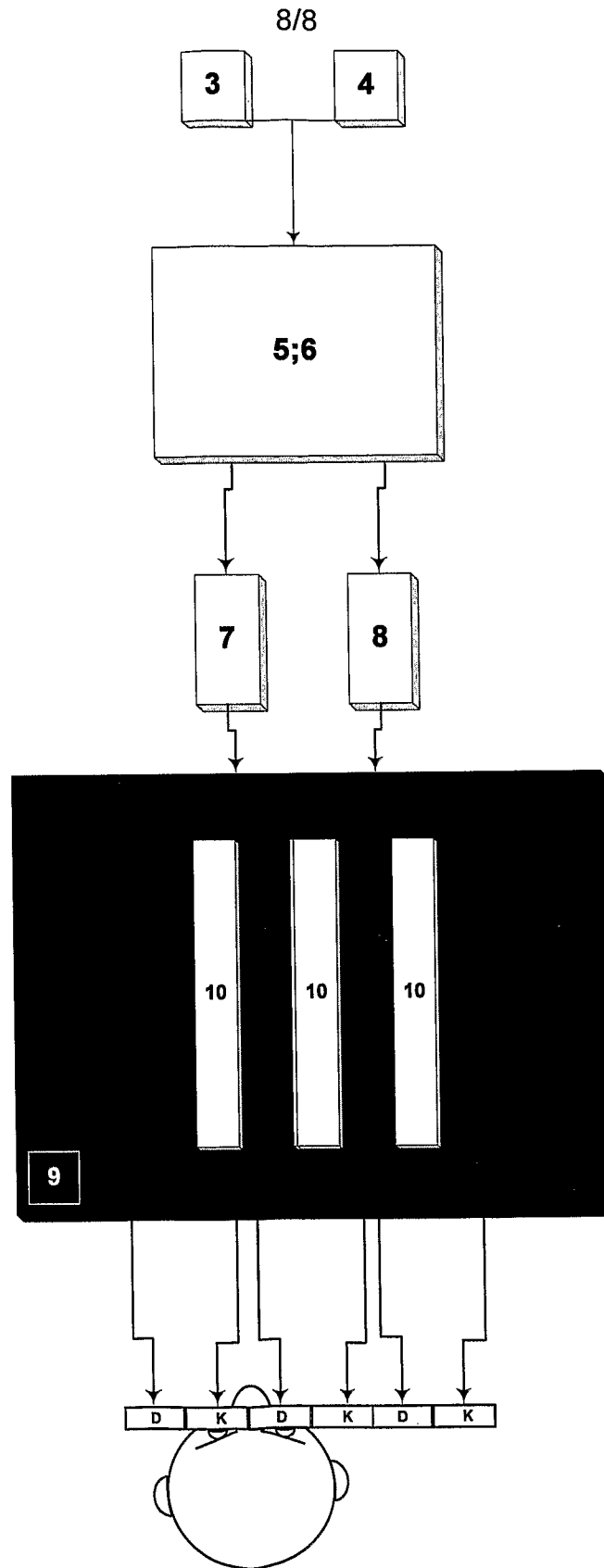

Fig. 6b