



(11) **EP 2 035 742 B1**

(12) **EUROPEAN PATENT SPECIFICATION**

(45) Date of publication and mention of the grant of the patent:  
**16.02.2011 Bulletin 2011/07**

(51) Int Cl.:  
**F17C 13/08<sup>(2006.01)</sup> F17C 3/02<sup>(2006.01)</sup>**

(21) Application number: **07747666.1**

(86) International application number:  
**PCT/NO2007/000216**

(22) Date of filing: **19.06.2007**

(87) International publication number:  
**WO 2007/148982 (27.12.2007 Gazette 2007/52)**

(54) **AN ARRANGEMENT FOR A CYLINDRICAL TANK FOR TRANSPORTATION OF LIQUEFIED GASES AT LOW TEMPERATURE IN A SHIP**

ANORDNUNG FÜR EINEN ZYLINDRISCHEN TANK ZUM TRANSPORT VON VERFLÜSSIGTEN GASEN BEI NIEDRIGER TEMPERATUR IN EINEM SCHIFF

SYSTÈME DE RÉSERVOIR CYLINDRIQUE DESTINÉ AU TRANSPORT DE GAZ LIQUÉFIÉ À BASSE TEMPÉRATURE À BORD D'UN NAVIRE

(84) Designated Contracting States:  
**AT BE BG CH CY CZ DE DK EE ES FI FR GB GR HU IE IS IT LI LT LU LV MC MT NL PL PT RO SE SI SK TR**

(74) Representative: **Selmer, Lorentz et al**  
**Oslo Patentkontor AS**  
**P.O. Box 7007 M**  
**N-0306 Oslo (NO)**

(30) Priority: **19.06.2006 NO 20062869**

(56) References cited:  
**WO-A2-2006/001711 DE-A1- 19 524 680**  
**DE-C- 533 315 GB-A- 2 032 506**  
**JP-A- 02 085 600 NO-B- 146 351**  
**US-A- 3 319 431 US-A- 3 499 410**  
**US-A- 3 863 408 US-A- 3 979 005**  
**US-A- 3 979 005 US-A- 5 664 514**  
**US-B2- 6 595 382**

(43) Date of publication of application:  
**18.03.2009 Bulletin 2009/12**

(73) Proprietor: **Tanker Engineering AS**  
**0116 Oslo (NO)**

(72) Inventor: **AARSETH, Harald**  
**0256 Oslo (NO)**

**EP 2 035 742 B1**

Note: Within nine months of the publication of the mention of the grant of the European patent in the European Patent Bulletin, any person may give notice to the European Patent Office of opposition to that patent, in accordance with the Implementing Regulations. Notice of opposition shall not be deemed to have been filed until the opposition fee has been paid. (Art. 99(1) European Patent Convention).

## Description

**[0001]** The present invention relates to design, construction and support of large, independent, horizontal and generally cylindrical tanks onboard ships, and for the transportation of liquefied gases at low temperatures. The invention is also in principle applicable for so-called twin tanks consisting of two cylindrical tanks built together into one common tank.

**[0002]** Horizontal and independent cylindrical tanks have to a large extent been used for ships with relatively small total cargo capacity for transportation of liquefied gases at low temperatures, and the largest known and built ship with such cargo tanks has a total cargo capacity of about 30.000 m<sup>3</sup>.

**[0003]** However, for the last 20-30 years, several larger ships for transportation of liquefied gases have been built, and normal size and total cargo capacity have been in the range of 120.000 -160.000 m<sup>3</sup>. Recently, such ships with a total cargo capacity of more than 200.000 m<sup>3</sup> have been contracted and constructed.

**[0004]** Such larger ships have up to now mainly been built according to two different design concepts, namely the membrane type of cargo tanks and the independent spherical cargo tanks.

**[0005]** The non-application of cylindrical tanks for such larger ships for liquefied gas is a "missing link" in the development so far.

**[0006]** As noted above, independent cylindrical tanks have not been applied for the largest ships for liquefied gases, notwithstanding that with regard to design, fabrication and installation onboard ships, such cylindrical tanks should be preferable, for example as compared to spherical tanks.

**[0007]** A spherical tank has only one degree of freedom (diameter), while a cylindrical tank has two degrees of freedom (diameter and length) which favours the arrangement and installation in a surrounding hull.

**[0008]** Furthermore, the fabrication and construction of a cylindrical tank is much simpler than for a spherical tank.

**[0009]** However, for the last 5-10 years, ships of the so-called membrane type have been the dominating type and alternative for large ships for transportation of liquefied natural gas (LNG). But these ships have limitations in their performance, and especially with regard to strengthwise capability of the cargo containment system for withstanding liquid motions (sloshing) when the ship is exposed to rough seas. Because of risk for damages due to sloshing, these types of ships are not permitted to have partial fillings in cargo tanks between about 20% and about 80% of full tanks when the ships are at sea.

**[0010]** But even with such filling restrictions, from time to time, damages have occurred to membranes and insulation boxes of the cargo containment system due to sloshing. The number of cargo tanks is a significant parameter for the costs for building of ships for LNG. It may be worth mentioning that for the largest ships under con-

tract and construction, it has been necessary to increase the number of cargo tanks from four to five (compared to membrane ships of somewhat smaller size), and the ships have become relatively more expensive to build.

**[0011]** A common weakness/disadvantage of LNG ships of the membrane and spherical tank types is the arrangement for pipes, electric cables and internal access between the top and bottom of cargo tanks. The distance between top and bottom can be in the range of 40-45 metres, and a freestanding tower has to be provided inside each cargo tank for supporting and clamping of pipes and cables, as well as for ladders for access to the bottom of the tank.

**[0012]** Furthermore, these towers must have sufficient strength to withstand sloshing at sea, and as a result, the towers are becoming rather complicated and expensive constructions.

**[0013]** A conceivable alternative for applying independent cylindrical tanks for the large and largest ships for transportation of liquefied gases could be an upscaling of existing constructions of applied cylindrical tanks for smaller types of liquefied gas carriers.

**[0014]** For such smaller types of liquefied gas carriers, the independent cylindrical tanks are supported in two saddle constructions, such saddle constructions being integrated in surrounding hull constructions. Between cargo tank (either made of aluminium, stainless steel or low-temperature steel) and the saddle construction of steel there is provided a thermal insulating material of sufficient strength to carry the weight of a full cargo tank.

**[0015]** The critical load points for such cylindrical tanks will be at the supports and at shell and internal reinforcements in way of the supports. The internal reinforcements for the smaller type of ships/tanks consist normally of

1) a single ring stiffener with flange, or

2) a single ring stiffener with flange in association with a single circular perforated wash bulkhead.

**[0016]** Such kinds of reinforcements are sufficient for rather small and medium sized liquefied gas carriers, and restrictions for filling level in such smaller cargo tanks are normally not necessary. Examples of both reinforcements are shown in GB 2032506 A, which is the closest prior art upon which the preamble of the independent claim 1 is based.

**[0017]** Larger ships with horizontal cylindrical tanks, and with internal reinforcements as 1) above, will most likely have restrictions for tilling levels of the tanks due to sloshing at sea.

**[0018]** Internal reinforcements as 2) above will for large tanks not be realistic due to difficulties for stiffening such a single wash bulkhead of large diameter. These two types of constructions/reinforcements have also limited radial stiffness and strength, and this limitation will become more and more significant as the tanks become larger. Accordingly, this lack of stiffness and strength will

result in radial deformations along the periphery of the tanks at the support areas, and these deformations and accompanying stresses will be difficult to calculate exactly. Furthermore, deformations in the surrounding hull due to different draughts and sea states will be transferred to the support system and the cargo tanks.

**[0019]** The fact that the surrounding hull with saddle constructions will be deformed, and the fact that the tanks in the support area will have radial deformations, will make exact pre-calculation of stress levels in cargo tank elements rather difficult. However, such exact pre-calculation of stresses is compulsory requirements from applicable national/international authorities and classification societies, and types of constructions/reinforcements applied for cylindrical tanks on smaller ships, are very difficult or even not possible to apply on larger ships.

**[0020]** The present invention is providing technical solutions enabling application of large independent cylindrical tanks for transportation of liquefied gases, and especially liquefied natural gas (LNG). Furthermore, the present invention alleviates the above-mentioned major weaknesses/disadvantages of other design concepts. An arrangement according to the invention is defined in claim 1 and a method according to the invention is defined in claim 12.

**[0021]** Especially, the invention is providing good technical solutions for the following important items:

- ~ Avoiding significant restrictions for filling level of cargo tanks at sea.
- ~ Permits a limited and minimum number of cargo tanks to be achieved (2, 3 or maximum 4 cargo tanks, depending on total cargo capacity).
- ~ Permits a simplified internal arrangement in the cargo tanks for pipes, electric cables and access between top and bottom of a cargo tank.

**[0022]** Furthermore, the present invention are providing constructions/reinforcements internally in the tanks at the supports enabling exact stress calculations in materials for cargo tanks and surrounding hull structures at the prevailing load conditions.

**[0023]** The invention consists mainly of providing two perforated circular wash bulkheads beside one other internally in the cargo tank at each support. The distance between the circular wash bulkheads will normally be in the range of 1 - 4 metres. Between the perforated circular wash bulkheads, a framework of girders/stiffeners will be provided and welded, and such that the two circular perforated bulkheads will be connected to each other through a framework. The adjacent sections of external shell plates will subsequently be welded to the periphery of the circular perforated bulkheads and to the radial girders between the bulkheads. The two circular perforated bulkheads, the between-lying framework and the external shell plates will accordingly constitute a rigid wheel-

like construction.

**[0024]** The two circular bulkheads in the construction will have many openings/perforations for quick balancing of differences in levels within the tank. The two circular and perforated bulkheads together with intermediate framework and external shell will be a very strong construction. The radial and global stiffness can be made almost infinite, and it will be almost impossible to have any global or local radial deformation of the tank at the prevailing external loads.

**[0025]** On this basis, the stress calculations of the cargo tank can be simplified and reliable, and the requirements for exact stress pre-calculations can be fulfilled. Furthermore, a double bulkhead with an intermediate framework will be able to withstand forces from sloshing in an efficient way, and local stresses where the bulkheads are attacked to the external shell will be much smaller than for a single bulkhead. As an example, if such a ship with cylindrical cargo tanks with total cargo capacity of 145.000 m<sup>3</sup> is provided with three cargo tanks, it is expected that the ship will have no restrictions for partial filling of cargo tanks by optimization of perforations in the internal bulkheads.

**[0026]** From competition point of view, this is a clear advantage, as ships of membrane tank and spherical tank types need to have minimum four cargo tanks for 145.000 m<sup>3</sup> total cargo capacity. Moreover, the ships of membrane type of cargo tanks will as previously mentioned also have restrictions for partial filling at sea.

**[0027]** The space between the two circular and perforated bulkheads at each support can in an efficient manner be used for pipes, cables and access between top and bottom of the tank. A dome for connection of pipes and cables and with an access hatch is arranged straight above the double bulkhead.

**[0028]** The cargo tanks have ambient temperature when installed and adapted to the saddle support constructions of the hull. However, when the cargo tanks are cooled down at first loading of cargo (e.g. LNG), the diameter of the tanks will shrink about 60 mm in diameter for a steel tank of 30 meter diameter. At least theoretically, the tank might partially deviate from the original contact surface to the saddle support, and the subsequent risk for the tank to become unstable in the transverse direction when the ship is rolling in the sea, cannot be neglected.

**[0029]** This risk is eliminated by locking the domes (two for each tank) against transverse movement, so that the tank is always kept in same transverse position.

**[0030]** The arrangement of domes above the double wash bulkhead makes it possible to arrange internal stiffening plates in the dome, as well as to arrange external brackets at the domes in plane with the wash bulkheads. This enables the structures of the domes, as connected to the circular wash bulkheads, to withstand all prevailing transverse force and to transfer the forces to the surrounding deck structures. The transfer of transverse forces from the cargo tank via the dome to the surrounding

deck structure is permitted by a system of a specially arranged insulating 'tween material between domes and deck structures. The arrangement of the 'tween material is also taking care of required vertical and longitudinal movements due to temperature changes of the cargo tank. At the aft dome, the required possibility for vertical movement of cargo tank is arranged. At the forward dome, the required possibility for vertical and longitudinal movements is arranged. If the ship is prone to sagging and hogging, also the aft dome may permit some longitudinal movement.

**[0031]** An additional advantage of the present design concept is the possibility for production of the cylindrical sections at the supports with built-in bulkheads/frameworks with exact roundness. The circular and perforated bulkheads can be constructed and fully welded, and initially made with excess measurements. Upon final weldings, the bulkheads might be measured, marked and cut to the exact desired diameter, and exact circular roundness can be achieved and guaranteed. As next step, the adjacent shell plates can be welded to the circular and perforated bulkheads and adjoining frameworks, and exact roundness is still maintained.

**[0032]** With exact roundness of the tanks at the supports, the adapting of tanks to the saddle constructions of the hull will be facilitated.

**[0033]** Another new proposed item is the application of pressure sensors along the periphery of saddle constructions between tank and hull. Pressure loads on saddles can be monitored continuously, and can also be compared with pre-calculated loads along the periphery of the support system.

**[0034]** For better understanding of the invention it will be described more closely with reference to the exemplifying embodiments illustrated schematically in the appended drawings, where

Figs. 1A and 1B are a side view and plan view, respectively, of an LNG carrier embodying the present invention;

Figs. 2A and 2B are cross-sectional views along the line A-A in Fig. 1 illustrating two separate embodiments of the invention;

Fig. 3 is a sectional view along the line B-B in Figs. 2A and 2B;

Fig. 4 shows at a larger scale Detail 3 from Fig. 3;

Figs. 5A and 5B show at a larger scale Detail 1 from Fig. 1; and

Figs. 6A and 6B show at a larger scale Detail 2 from Fig. 1.

**[0035]** Fig. 1A and 1B show a general arrangement plan for a LNG-carrier 1 of about 145.000 m<sup>3</sup> total cargo

capacity, and with three cylindrical cargo tanks.

**[0036]** Fig.2A and Fig.2B show a transverse section through the ship and through a cargo tank (see Fig.1A Section A-A), and the section is shown between the perforated bulkheads 3 at one of the supports for one cargo tank.

**[0037]** The figures show two alternative arrangements/solutions for frameworks between the circular and perforated bulkheads.

**[0038]** The between-lying framework shown in Fig.2A consists of vertical 4 and horizontal 5 plate girders.

**[0039]** Outward is arranged a concentric ring girder 6, and between this concentric ring girder 6 and shell plates 2 of tank 2 is arranged radial girders 7. For optimum force transmission between shell and girders, it is important that forces are transferred vertically towards the shell plates.

**[0040]** The between-lying framework shown in Fig.2B consists of concentric ring girders 6 and radial girders 7.

**[0041]** For both figures/alternatives are schematically shown ladders 8 and pipes/cables 9 between top and bottom of tanks.

**[0042]** Both figures/alternatives show in principle perforations/openings 10 in a bulkhead, and final number/locations of perforations/openings in the bulkheads will be subject to further considerations/calculations, and for achieving optimum results with regard to minimum load/stresses on bulkheads and shell from sloshings in the tank at sea.

**[0043]** Both figures/alternatives show that the cargo tanks are provided with external thermal insulation 11, saddle supports 12 and an insulating and a weight-bearing material between saddle support and cargo tank 13.

**[0044]** Fig. 3 show section B-13 as indicated on Fig. 2A and Fig.2B, and show the two perforated bulkheads 3 at a certain distance from each other. This distance is previously indicated to be in the range of 1-4 metres. The figure shows as well the principle for locking the tank at the saddle support against movement in longitudinal direction at one of the supports. At the other support, the tank 2 is free to slide in longitudinal direction.

**[0045]** Fig. 3 also shows that vertical and horizontal girders (including concentric girders) are provided with openings 10 and 14 for free flow of liquid cargo, and for access to all spaces between the circular bulkheads.

**[0046]** Fig.4 shows Detail 3 as referred to on Fig.3, and shows arrangement for transfer of forces (mainly because of sloshing) in longitudinal direction from bulkheads 3 and radial plates 7 to the external shell plates 17.

**[0047]** Internally in the tank is shown bracket 15 at transition between bulkhead 3 and shell 17, and externally in same plane is shown bracket 16. Both these brackets is sniped and grounded towards zero at the termination towards shell. Furthermore, external brackets 18 are shown in the support zone, and in same radial plane as other brackets 15 and 16 and internal radial plate 7. Arrangement of last-mentioned bracket 18 is characterized by cutting of space for the bracket in the 'tween material

13 between tank and saddle support. For locking of the tank in longitudinal direction, flat bars 19 are arranged externally along the periphery in the support zone of the tank.

**[0048]** Corresponding flat bars 20 are arranged on the saddle support 12 for locking of the 'tween material 13 to the saddle support 12 and to the surrounding hull 1.

**[0049]** Fig. 5A and Fig. 5B of Detail 1 as referred to on Fig. 1A show the principle for locking the tank 2 in transverse and longitudinal directions at aft dome 23. The concentric ring 21 are fixed to the hull 1, and concentric ring 22 are fixed to the aft dome 23, and the surface between the concentric rings will act as sliding surface for vertical movements of the aft dome 23 due to changes in temperature of the tank 2. Material quality for these concentric rings might be same as applied between cargo tank and saddle support.

**[0050]** However, the aft dome 23 and the tank 2 is locked for movements in transverse and longitudinal directions, and the dynamic forces on the cargo tank 2 when the ship is at sea, are transferred from the tank 2 via the aft dome 23 and concentric rings 21 and 22 to the hull 1. In order to withstand and transfer the forces, the aft dome 23 is internally reinforced by vertical reinforcing plates 24, and horizontal reinforcing plates 25.

**[0051]** The vertical reinforcing plates 24 are assumed to be arranged in same plane as the two circular wash bulkheads 3, and in same plane is as well arranged brackets 26 between aft dome 23 and shell plates 17 of the tank for reducing stress concentrations at the transfer of forces.

**[0052]** Fig. 5B shows mainly Section C - C as indicated in Fig. 5A.

**[0053]** Fig. 6A and Fig. 6B of Detail 2 as referred to on Fig. 1A show the principle at forward dome 29 for locking the tank 2 in transverse direction, and at the same time to secure free movement of forward dome 29 and the tank 2 in vertical and longitudinal directions due to temperature changes. The intermediate elements 27 and 28 are arranged between forward dome and the surrounding hull 1. The inner element 27 is fixed to the dome, and the outer elements 28 (two separate pieces) are fixed to the hull 1, and the joint surfaces of the inner element 27 and the outer elements 28 are acting as sliding surfaces for vertical and longitudinal movements of the forward dome 29 due to changes in temperature of the tank 2. Material quality for these intermediate elements might be same as applied between cargo tank and saddle support.

**[0054]** However, by the shown arrangement, the forward dome 29 and the tank 2 is locked for movements in transverse direction, and the dynamic transverse forces on the cargo tank 2 are transferred from the tank 2 via the forward dome 29 and intermediate elements 27 and 28 to the hull 1. In order to withstand and transfer the forces, the forward dome 29 is internally reinforced by vertical reinforcing plates 30, and horizontal reinforcing plates 31.

**[0055]** The vertical reinforcing plates 30 are assumed

to be arranged in same plane as the two circular wash bulkheads 3,

**[0056]** And in same plane is as well arranged brackets 32 between forward dome 29 and shell plates 17 of the tank for reducing stress concentrations at the transfer of forces.

**[0057]** Fig. 6B shows mainly Section D - D as indicated in Fig. 6A.

**[0058]** It will be understood that the present invention is not limited to the exemplifying embodiments described above, but may be varied and modified by the skilled person within the scope of the appended claims.

## 15 Claims

1. An arrangement for a horizontal and generally cylindrical tank (2) for transportation of liquefied gases at low temperature onboard ships, wherein the tank (2) is supported in the ship in at least two supports (12), and wherein the tank has an internal reinforcement comprising a perforated and stiffened bulkhead at each support, **characterized in that** the internal reinforcement at each support, comprises two adjacent circular and perforated bulkheads (3) with an intermediate space therebetween, and that a framework system of crossing stiffeners (4-7) is arranged and welded to the adjacent bulkheads in the intermediate space.
2. An arrangement according to claim 1, wherein an aft dome (23) is arranged in conjunction with the two adjacent circular and perforated bulkheads (3) at an aft cargo tank saddle support for enabling the aft dome by internal reinforcements (24, 25) and external brackets (26) in line with bulkheads (3) to transfer transverse and longitudinal forces between cargo tank (2) via intermediate elements (22, 23) to the hull (1), and simultaneously to allowing the aft dome (23) to slide in the vertical direction.
3. An arrangement according to claim 1 or 2, wherein a forward dome (29) is arranged in conjunction with the two adjacent circular and perforated bulkheads (3) at a forward cargo tank saddle support for enabling the forward dome by internal reinforcements (30) and external brackets (32) in line with bulkheads (3) to transfer transverse forces between cargo tank (2) via intermediate elements (27, 28) to the hull (1), and simultaneously to allowing the forward dome (29) to slide in the vertical and longitudinal directions.
4. An arrangement according to claim 1, wherein the bulkheads (3) have openings (10) areas of the respective bulkhead limited by the nearest girders (4-7).

5. An arrangement according to claim 1 or 4, wherein space between the bulkheads (3) is utilized for protective running of pipes and electric cables (9), and for providing access (8) between the top and bottom of the tank.
6. An arrangement according to claim 1, 4 or 5, wherein the stiffeners are comprising tangential and radial oriented plates (6, 7).
7. An arrangement according to claim 6, wherein stiffeners also are comprising vertical and horizontal plates (4, 5).
8. An arrangement according to claim 6 or 7, wherein at least some of the stiffening plates (4-7) are provided with openings (14).
9. An arrangement according to any one of the preceding claims, wherein the support system is of the saddle type support (12) with a bearing insulation material (13) in the same length as the distance between the internal bulkheads (3), the 'tween material (13) being locked against movement by flat bar flanges (19) welded to the shell (17) of the tank (2) and reinforced with brackets (16,18) preferably being sniped, sniped brackets (15) also being provided between the shell (17) of tank (2) and the bulkheads (3).
10. An arrangement according to claim 9, wherein pressure transducers are provided and arranged along the periphery of the support system, the vertical pressure from tank to supports being continuously monitored and recorded.
11. An arrangement according to any one of the preceding claims, wherein the tank (2) has a cargo volume in the range of 40.000 - 60.000 m<sup>3</sup>, and wherein the distance between the adjacent bulkheads (3) at a support preferably is in the range of. 1-4 metres.
12. A method for the construction of a generally cylindrical tank for transportation of liquefied gases at low temperatures in ships, which tank (2) is provided with at least two areas for support in the ship (1), each area having internal reinforcement comprising a circular and perforated bulkhead, **characterized in that** the reinforcement at each area is made in the form of two adjacent perforated bulkheads (3) and is fabricated with oversized diameter and a framework of crossing stiffeners (4-7) welded between the bulkheads (3), whereupon the bulkheads (3) and outer stiffeners (7) are cut to exact diameter and roundness before shell plates (17) of the tank (2) are welded to the bulkheads (3) and outer stiffeners (7).

## Patentansprüche

1. Anordnung für einen waagerechten und im Allgemeinen zylindrischen Tank (2) zum Transport von Flüssiggasen bei niedriger Temperatur auf Schiffen, wobei der Tank (2) auf dem Schiff in mindestens zwei Trägern (12) getragen wird, und wobei der Tank eine interne Verstärkung aufweist, die ein perforiertes und versteiftes Schott an jedem Träger umfasst, **dadurch gekennzeichnet, dass** die interne Verstärkung an jedem Träger zwei angrenzende kreisförmige und perforierte Schotte (3) mit einem Zwischenraum dazwischen umfasst, und dass ein Rahmenbausystem aus gekreuzten Aussteifungen (4 bis 7) angeordnet und an die angrenzenden Schotte in dem Zwischenraum angeschweißt ist.
2. Anordnung nach Anspruch 1, wobei eine hintere Kuppel (23) zusammen mit den beiden angrenzenden kreisförmigen und perforierten Schotten (3) an einem hinteren Ladetanksattelträger angeordnet ist, um es der hinteren Kuppel durch interne Verstärkungen (24, 25) und externe Stützen (26) in Reihe mit den Schotten (3) zu ermöglichen, Quer- und Längskräfte zwischen dem Ladetank (2) über Zwischenelemente (22, 23) auf den Rumpf (1) zu übertragen, und es der hinteren Kuppel (23) gleichzeitig zu ermöglichen, in der senkrechten Richtung zu gleiten.
3. Anordnung nach Anspruch 1 oder 2, wobei eine vordere Kuppel (29) zusammen mit den beiden angrenzenden kreisförmigen und perforierten Schotten (3) an einem vorderen Ladetanksattelträger angeordnet ist, um es der vorderen Kuppel durch interne Verstärkungen (30) und externe Stützen (32) in Reihe mit den Schotten (3) zu ermöglichen, Querkräfte zwischen dem Ladetank (2) über Zwischenelemente (27, 28) auf den Rumpf (1) zu übertragen, und es der vorderen Kuppel (29) gleichzeitig zu ermöglichen, in der senkrechten Richtung und der Längsrichtung zu gleiten.
4. Anordnung nach Anspruch 1, wobei die Schotte (3) Öffnungsbereiche (10) des jeweiligen Schotts aufweisen, die durch die nächstgelegenen Balken (4 bis 7) begrenzt sind.
5. Anordnung nach Anspruch 1 oder 4, wobei der Raum zwischen den Schotten (3) zum geschützten Durchgang von Rohren und elektrischen Kabeln (9) verwendet wird, und um Zugriff (8) zwischen dem Oberteil und dem Unterteil des Tanks bereitzustellen.
6. Anordnung nach Anspruch 1, 4 oder 5, wobei die Aussteifungen tangential und radial orientierte Platten (6, 7) umfassen.
7. Anordnung nach Anspruch 6, wobei die Aussteifun-

gen ebenfalls senkrechte und waagerechte Platten (4, 5) umfassen.

8. Anordnung nach Anspruch 6 oder 7, wobei mindestens einige der Aussteifungsplatten (4 bis 7) mit Öffnungen (14) versehen sind. 5
9. Anordnung nach einem der vorhergehenden Ansprüche, wobei das Tragsystem ein sattelartiger Träger (12) mit einem Lagerisoliermaterial (13) der gleichen Länge wie der Abstand zwischen den internen Schotten (3) ist, wobei das Zwischenmaterial (13) durch flache Stangenflansche (19), die an dem Mantel (17) des Tanks (2) angeschweißt und mit Stützen (16, 18) verstärkt sind, die bevorzugt geschellt sind, gegen Bewegung blockiert ist, wobei geschellte Stützen (15) auch zwischen dem Mantel (17) des Tanks (2) und den Schotten (3) bereitgestellt werden. 10
10. Anordnung nach Anspruch 9, wobei Drucksensoren bereitgestellt werden und an dem Umfang des Trägersystems entlang angeordnet sind, wobei der senkrechte Druck von dem Tank auf die Träger durchgehend überwacht und aufgezeichnet wird. 15
11. Anordnung nach einem der vorhergehenden Ansprüche, wobei der Tank (2) ein Ladevolumen im Bereich von 40.000 bis 60.000 m<sup>3</sup> aufweist, und wobei der Abstand zwischen den angrenzenden Schotten (3) an einem Träger bevorzugt in dem Bereich von 1 bis 4 Metern liegt. 20
12. Verfahren zur Konstruktion eines im Allgemeinen zylindrischen Tanks zum Transport von Flüssiggasen bei niedriger Temperatur auf Schiffen, wobei der Tank (2) mit mindestens zwei Bereichen zum Tragen auf dem Schiff (1) versehen ist, wobei jeder Bereich eine interne Verstärkung aufweist, die ein kreisförmiges und perforiertes Schott umfasst, **dadurch gekennzeichnet, dass** die Verstärkung an jedem Bereich in Form von zwei angrenzenden perforierten Schotten (3) besteht und mit übermäßigem Durchmesser und einem Rahmenbau aus gekreuzten Aussteifungen (4 bis 7), die zwischen den Schotten (3) geschweißt sind, hergestellt wird, wonach die Schotte (3) und äußeren Aussteifungen (7) auf einen genauen Durchmesser und eine genaue Rundheit zugeschnitten werden, bevor Mantelplatten (17) des Tanks (2) an die Schotte (3) und die äußeren Aussteifungen (7) geschweißt werden. 25

le réservoir (2) est supporté dans le navire dans au moins deux supports (12) et dans lequel le réservoir a un renfort interne comprenant une cloison perforée et renforcée au niveau de chaque support, **caractérisé en ce que** le renfort interne au niveau de chaque support comprend deux cloisons adjacentes circulaires et perforées (3) avec un espace intermédiaire entre elles, et **en ce qu'un** système de cadre constitué de raidisseurs croisés (4-7) est disposé et soudé aux cloisons adjacentes dans l'espace intermédiaire.

2. Montage selon la revendication 1, dans lequel un dôme arrière (23) est disposé en combinaison avec les deux cloisons circulaires adjacentes et perforées (3) au niveau d'un support de patin de réservoir de chargement arrière pour permettre au dôme arrière, par le biais de renforts internes (24, 25) et de supports externes (26) alignés avec les cloisons (3), de transférer des forces transversales et longitudinales entre le réservoir de chargement (2), par le biais d'éléments intermédiaires (22, 23), à la coque (1) et simultanément pour permettre au dôme arrière (23) de coulisser dans la direction verticale. 30
3. Montage selon la revendication 1 ou 2, dans lequel un dôme avant (29) est disposé en combinaison avec les deux cloisons circulaires adjacentes et perforées (3) au niveau d'un support de patin de réservoir de chargement avant, afin de permettre au dôme avant, par le biais de renforts internes (30) et de supports externes (32) alignés avec les cloisons (3), de transférer des forces transversales entre le réservoir de chargement (2), par le biais d'éléments intermédiaires (27, 28), à la coque (1) et simultanément pour permettre au dôme avant (29) de coulisser dans les directions verticale et longitudinale. 35
4. Montage selon la revendication 1, dans lequel les cloisons (3) ont des zones d'ouverture (10) de la cloison respective limitées par les poutres les plus proches (4-7). 40
5. Montage selon la revendication 1 ou 4, dans lequel l'espace entre les cloisons (3) est utilisé pour permettre le passage protégé de tuyaux et câbles électriques (9) et pour fournir l'accès (8) entre le haut et le bas du réservoir. 45
6. Montage selon la revendication 1, 4 ou 5, dans lequel les raidisseurs comprennent des plaques orientées de manière tangentielle et radiale (6, 7). 50
7. Montage selon la revendication 6, dans lequel les raidisseurs comprennent également des plaques verticales et horizontales (4, 5). 55
8. Montage selon la revendication 6 ou 7, dans lequel

## Revendications

1. Montage pour un réservoir horizontal et généralement cylindrique (2) pour le transport de gaz liquéfiés à basse température à bord de navires, dans lequel

au moins certaines des plaques de renfort (4-7) sont dotées d'ouvertures (14).

9. Montage selon l'une des revendications précédentes, dans lequel le système de support est du type à patin (12) avec un matériau d'isolation porteur (13) de la même longueur que la distance entre les cloisons internes (3), le matériel entre eux (13) étant bloqué contre tout mouvement par des brides de barre plate (19) soudées à la coque (17) du réservoir (2) et renforcées par des supports (16, 18) de préférence entaillés, des supports entaillés (15) étant également ménagés entre la coque (17) du réservoir (2) et les cloisons (3). 5  
10
10. Montage selon la revendication 9, dans lequel les transducteurs de pression sont fournis et disposés le long de la périphérie du système de support, la pression verticale provenant du réservoir aux supports étant contrôlée et enregistrée en continu. 15  
20
11. Montage selon l'une des revendications précédentes, dans lequel le réservoir (2) a un volume de chargement dans la gamme de 40 000 - 60 000 m<sup>3</sup>, et dans lequel la distance entre les cloisons adjacentes (3) et un support est de préférence dans la gamme de 1-4 mètres. 25
12. Procédé pour la construction d'un réservoir généralement cylindrique pour le transport de gaz liquéfiés à basses températures dans des navires, ledit réservoir (2) étant doté d'au moins deux zones de support dans le navire (1), chaque zone ayant un renfort interne comprenant une cloison circulaire et perforée, 30  
35  
**caractérisé en ce que** le renfort dans chaque zone est réalisé sous la forme de deux cloisons perforées adjacentes (3) et est fabriqué avec un diamètre surdimensionné et un cadre constitué de raidisseurs croisés (4-7) soudés entre les cloisons (3), où les cloisons (3) et les raidisseurs extérieurs (7) sont coupés au diamètre et à l'arrondi exacts avant que les plaques de coque (17) du réservoir (2) ne soient soudées aux cloisons (3) et aux raidisseurs extérieurs (7). 40  
45

50

55

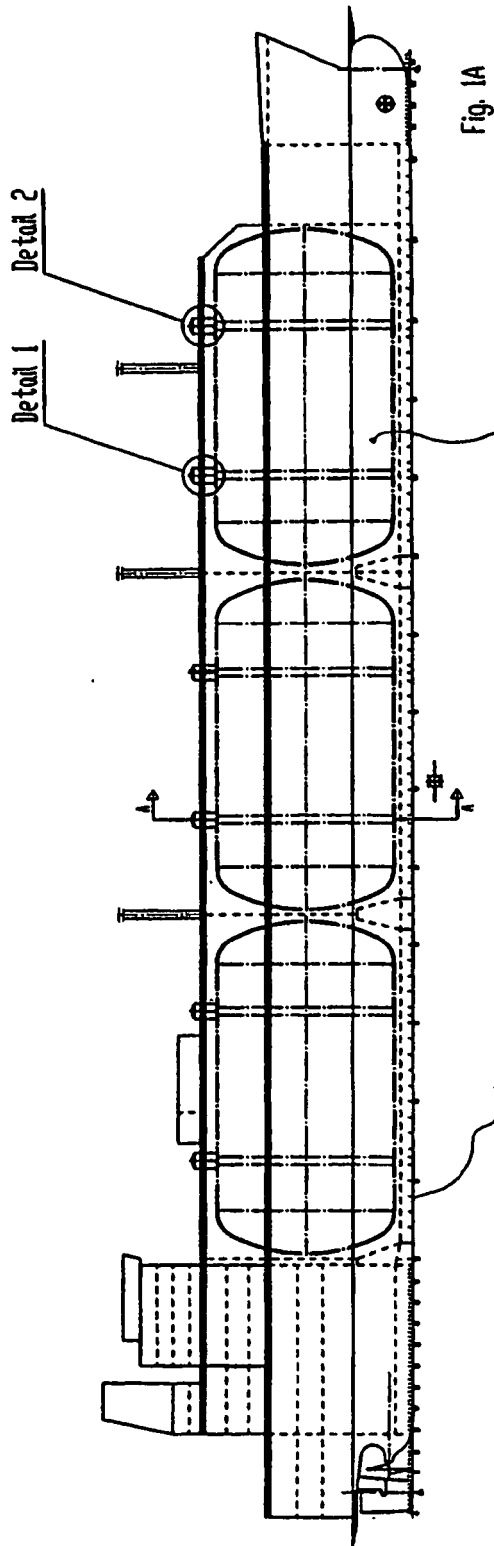

Fig. 1A

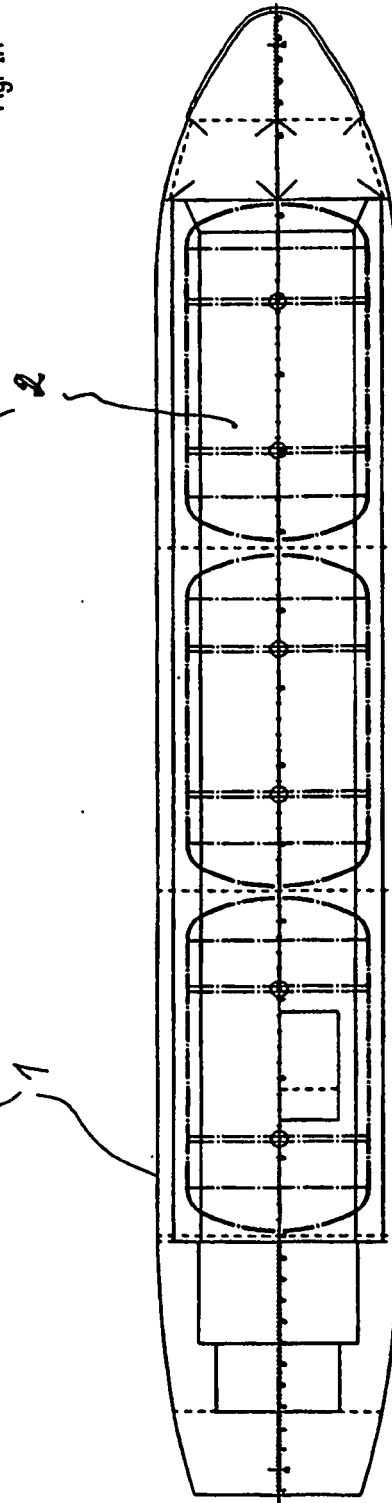

Fig. 1B

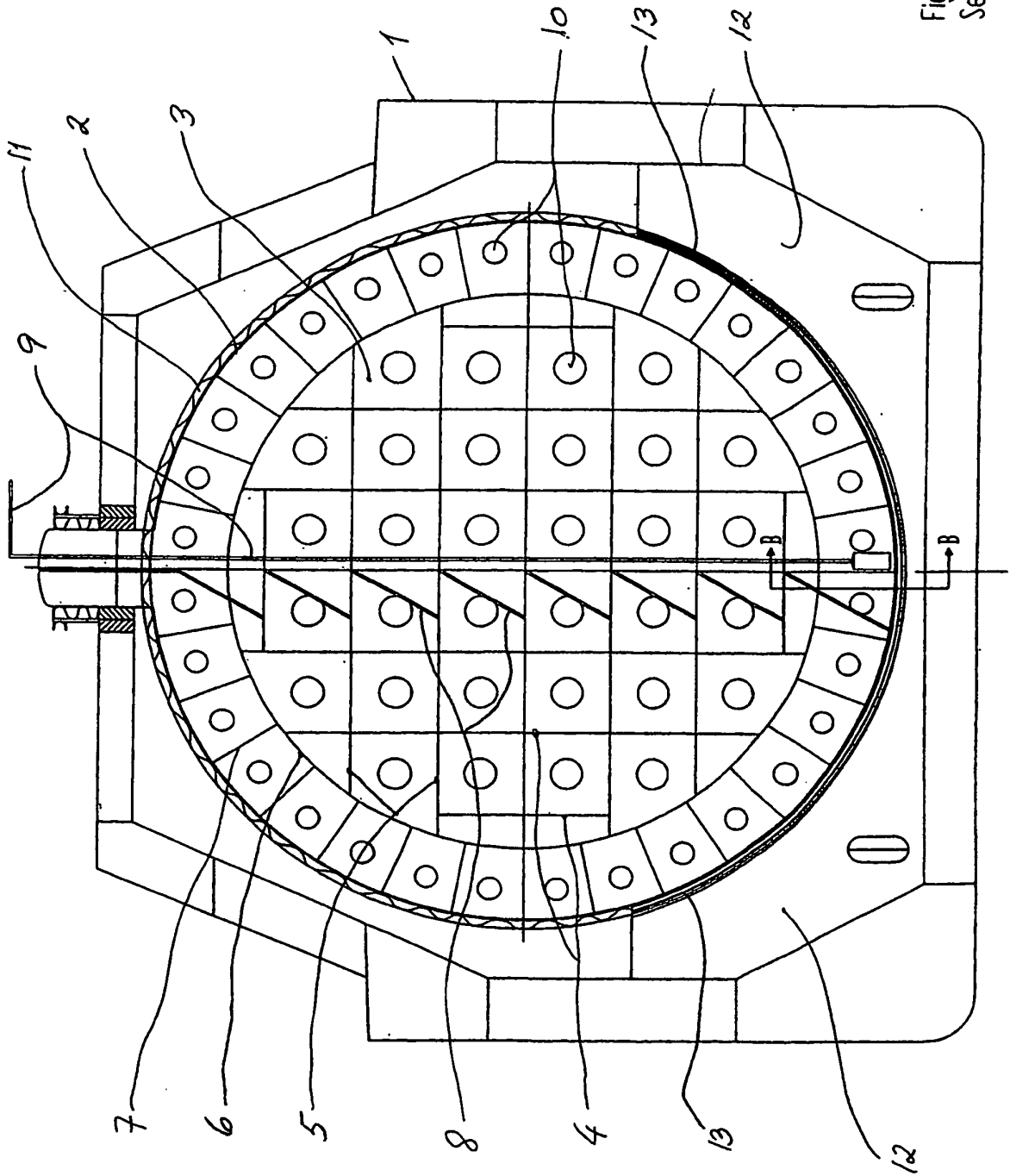

Fig. 2A  
Section A-A

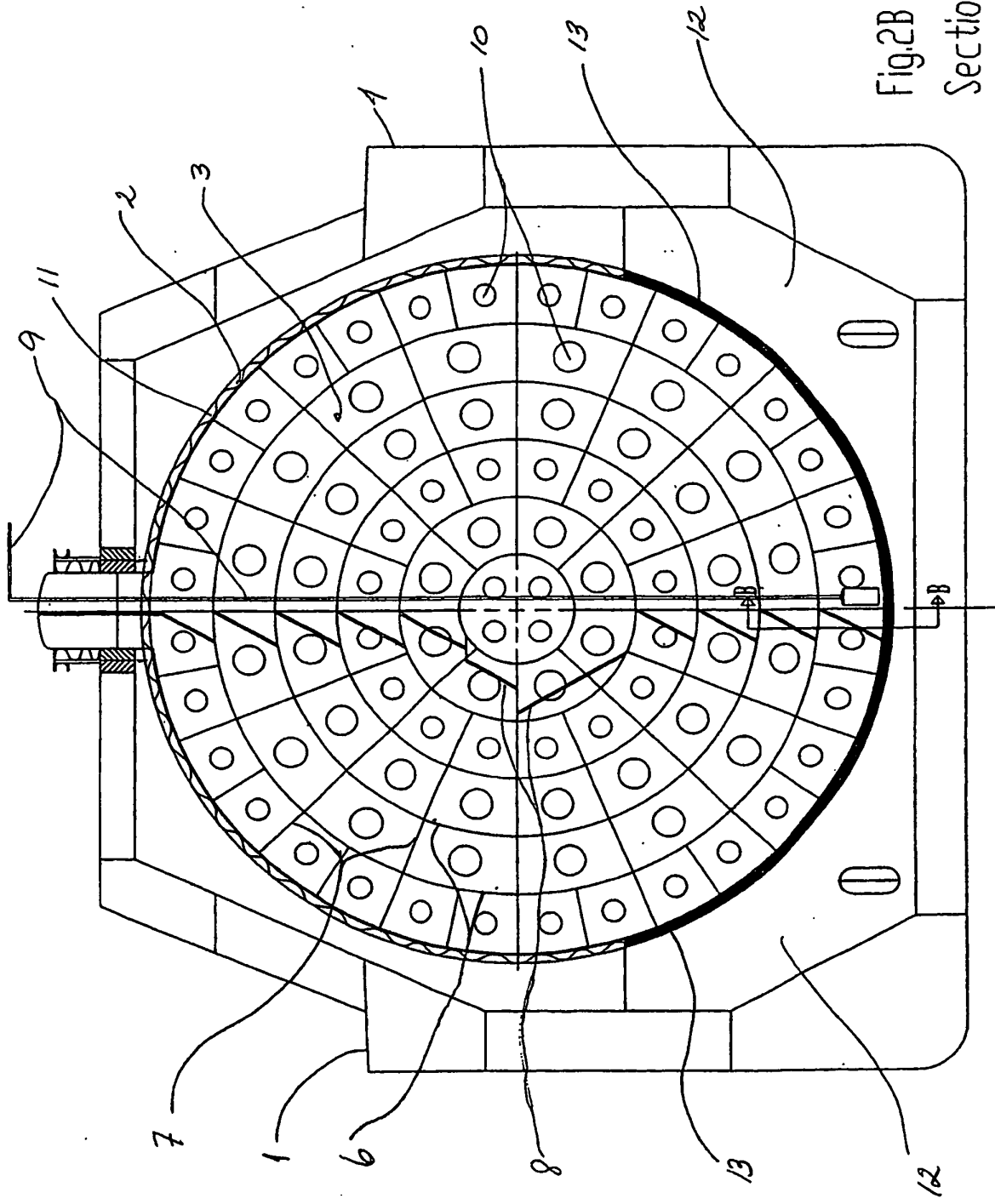
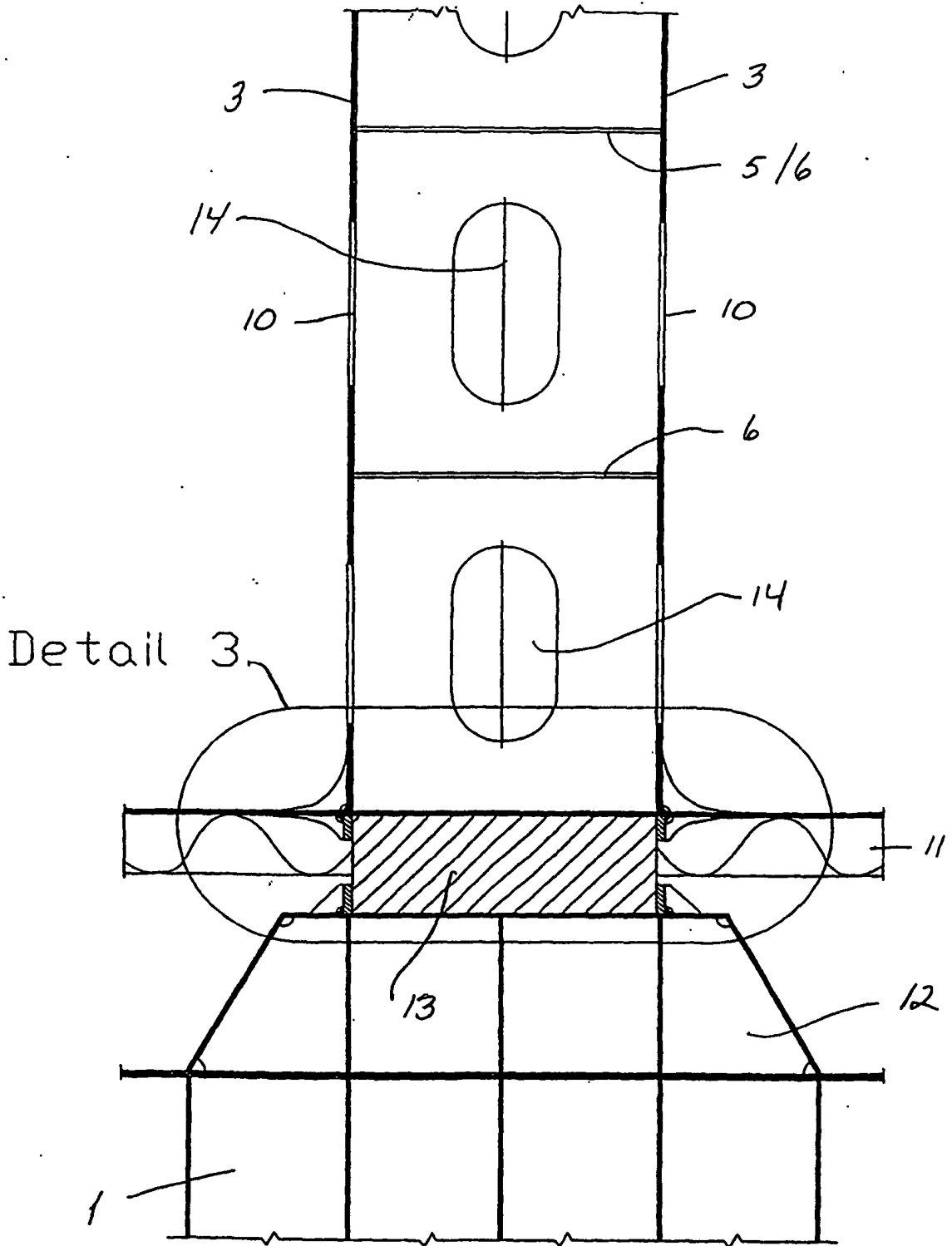
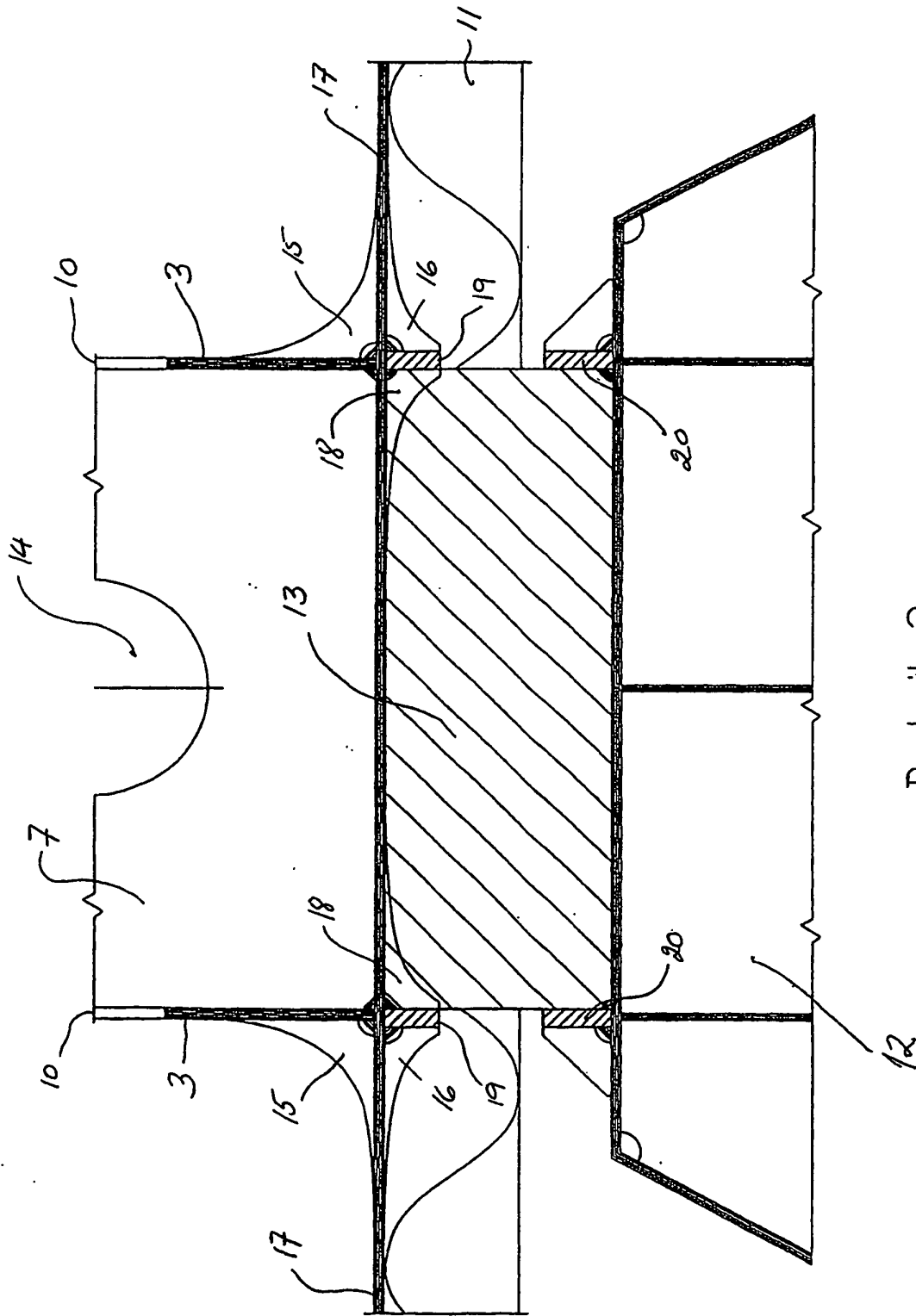

Fig.2B  
Section A-A



Section B-B

Fig. 3



Detail 3

Fig. 4

# Detail 1

## AFT DOME

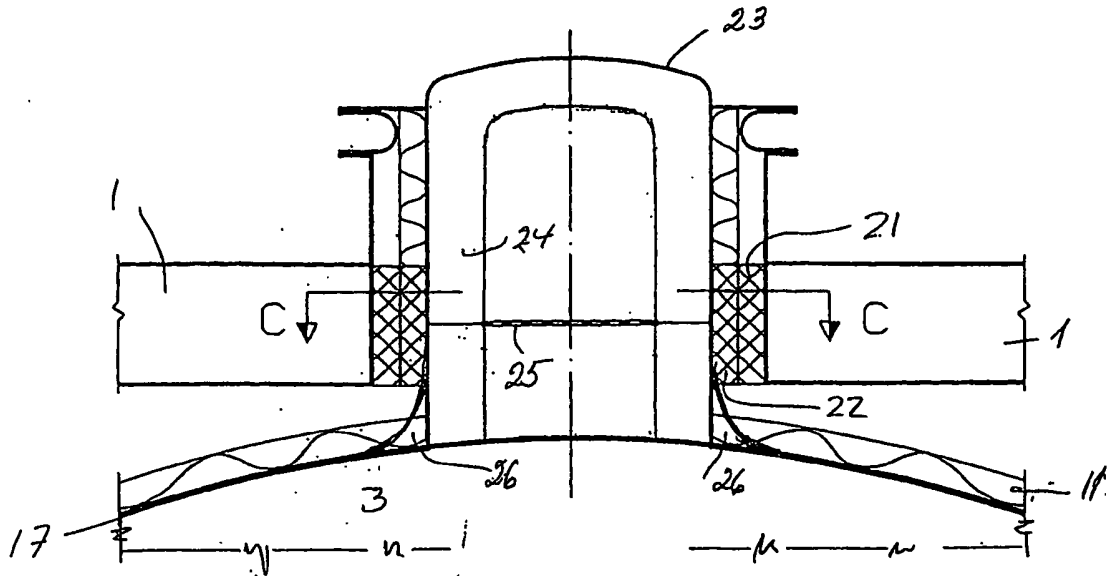
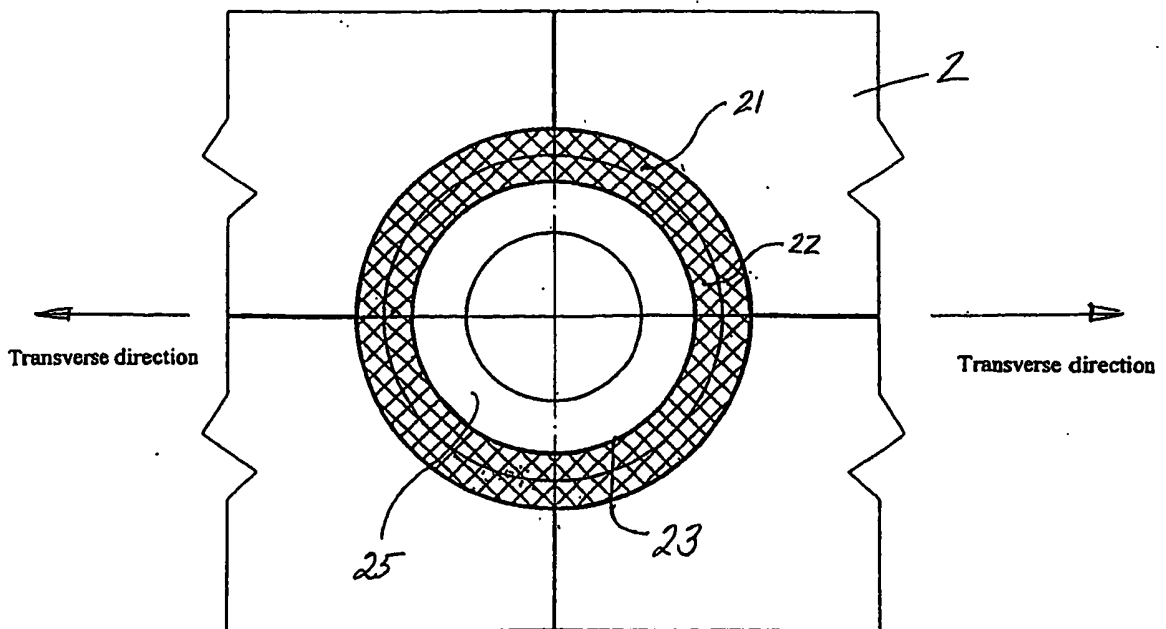

Fig. 5A



Section C-C

Fig. 5B

# Detail 2

## FORWARD DOME

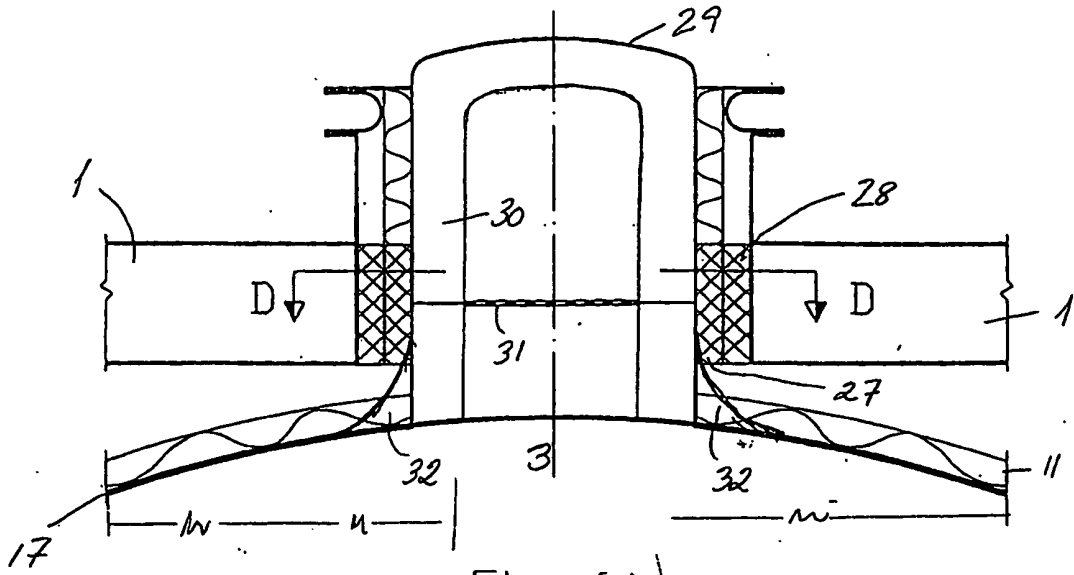
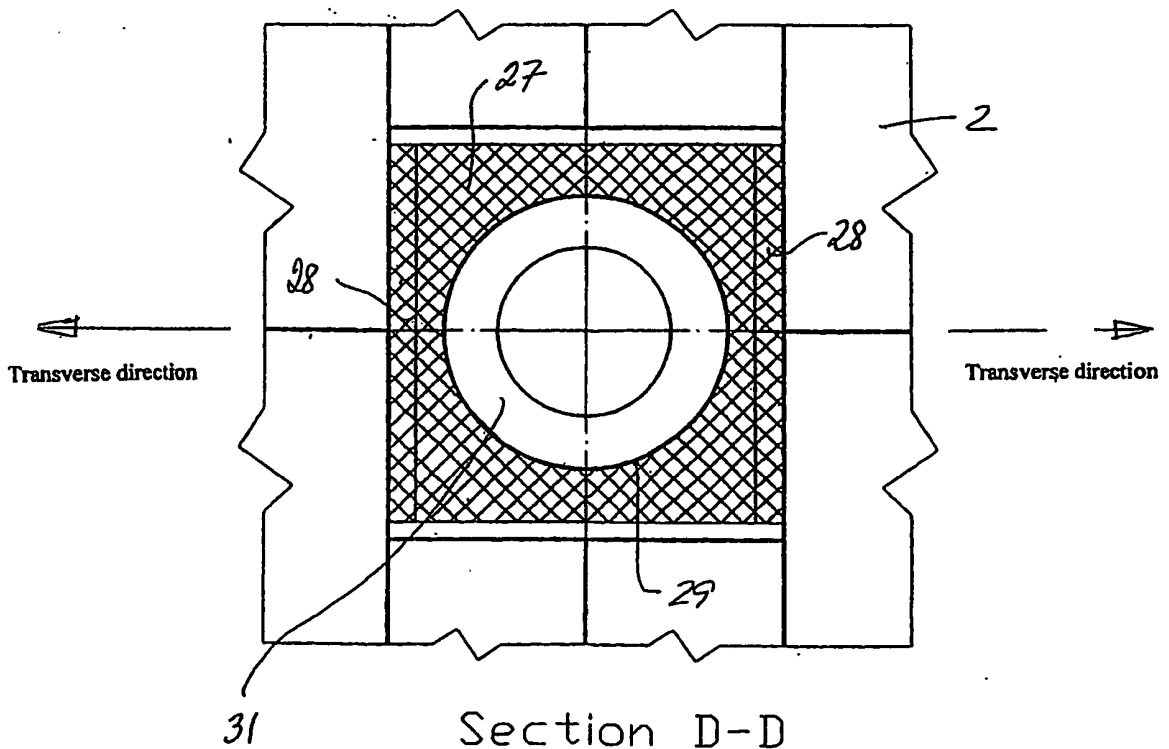

Fig. 6A



Section D-D

Fig. 6B

**REFERENCES CITED IN THE DESCRIPTION**

*This list of references cited by the applicant is for the reader's convenience only. It does not form part of the European patent document. Even though great care has been taken in compiling the references, errors or omissions cannot be excluded and the EPO disclaims all liability in this regard.*

**Patent documents cited in the description**

- GB 2032506 A [0016]