

(19)



Europäisches Patentamt

European Patent Office

Office européen des brevets



(11)

**EP 0 541 642 B1**

(12)

**EUROPEAN PATENT SPECIFICATION**

(45) Date of publication and mention  
of the grant of the patent:  
**17.01.1996 Bulletin 1996/03**

(51) Int. Cl.<sup>6</sup>: **B65D 5/54**, B65D 5/56,  
B65D 5/66

(21) Application number: **91914003.8**

(86) International application number: **PCT/GB91/01278**

(22) Date of filing: **29.07.1991**

(87) International publication number: **WO 92/02424**  
**(20.02.1992 Gazette 1992/05)**

(54) **PACKAGING CARTON AND BLANK THEREFOR**

FALTSCHACHTEL UND ZUSCHNITT

CARTON DE CONDITIONNEMENT ET PIECE DE CARTON SERVANT A LE CONSTRUIRE

(84) Designated Contracting States:  
**AT BE CH DE ES FR GB LI NL**

(72) Inventor: **WONNACOTT, Roger, Joseph**  
**28 Trecarrell**  
**Cornwall PL15 9OF (GB)**

(30) Priority: **03.08.1990 GB 9017066**  
**09.10.1990 GB 9021893**

(74) Representative: **Newby, John Ross**  
**London WC1V 6DE (GB)**

(43) Date of publication of application:  
**19.05.1993 Bulletin 1993/20**

(56) References cited:  
**US-A- 2 459 666**                      **US-A- 2 836 343**  
**US-A- 3 048 324**                      **US-A- 3 951 333**  
**US-A- 4 017 016**

(73) Proprietor: **DAVID S. SMITH PACKAGING LIMITED**  
**Launceston, Cornwall, PL15 9HN (GB)**

**EP 0 541 642 B1**

Note: Within nine months from the publication of the mention of the grant of the European patent, any person may give notice to the European Patent Office of opposition to the European patent granted. Notice of opposition shall be filed in a written reasoned statement. It shall not be deemed to have been filed until the opposition fee has been paid. (Art. 99(1) European Patent Convention).

## Description

### Background of the Invention

This invention relates to an improved packaging carton made from stiff but foldable board material and in particular to a carton having an easy-open tear strip defined by at least one length of reinforcing material applied to the board material. The invention also relates to a blank formed from a sheet of board material incorporating a reinforced easy-open tear strip, the blank being cut from the board material in a manner to sever the length(s) of tear strip reinforcing material whereby part only of the incorporated material is available for its intended function of tearing board material in a carton folded up from the blank.

There are requirements in packaging for one carton format during transport, display and sale of the carton and its packaged contents, but a different format during use of the carton, following sale. Commonly the one format is a fully-closed carton and the different format is an open or openable carton. The use of reinforced tear strips is well known to permit the above-described format change and this invention relates to novel designs of carton and blanks that permit easy production, in an economical manner, of a wide range of new and useful format-changeable cartons. US-A-2836343 relates to such cartons and is acknowledged in the pre-characterising clause of the following claim 1.

### Summary of the Invention

In its carton aspect, the invention relates to a carton formed from stiff but foldable board material having at least one length of reinforcing material applied to the board material to define an easy-open tear strip delimiting first and second carton parts which parts are hingedly connected following use of the tear strip, which carton is characterised in that said at least one length of reinforcing material is longitudinally splittable and is cut through along a line transverse to its longitudinal direction, whereby on use of the tear strip, the line of cut represents the end of the tear, a split length of at least one of the torn lengths up to the line of cut providing edge reinforcement on at least one of the parts. Suitably the residue of the said at least one length serves as reinforcement for the hinge connection of the two parts.

In its blank aspect the invention relates to a one piece blank of stiff but foldable board material designed to be erected into a carton whose format can be changed by use of a tear strip to leave a carton base with a hinged lid, said blank including at least one length of reinforcing material applied to the board material to reinforce the tear strip, which blank is characterised in that said at least one length of reinforcing material is longitudinally splittable and extends from side to side of the blank but its use as a tear strip is limited to part only of its length by virtue of at least one cut in the board material which extends transversely across the at least one length inter-

mediate its ends, the residue of the torn length of reinforcing material serving as reinforcement for edges of the lid.

Suitably the board material is a pluri-ply corrugated paperboard. Preferably the reinforcing material is applied to the paperboard during its manufacture on a corrugator and conveniently is incorporated between plies thereof. A convenient reinforcing material is a tape known under the trade mark "Sesame" (available from Sesame Industries Ltd. of Quebec, Canada) which is fibre-based and incorporates a heat-sensitive adhesive.

The use of two tapes each of which is splittable longitudinally is particularly preferred.

The invention has particular utility in the provision of a fully closed parallelepipedic carton intended to contain a liner for packaged contents which when opened leaves a lid hinged to one wall of the carton for easy reclosing and access to the packaged contents via the openable lid.

The liner can be a rigid inner receptacle, also erected from stiff but foldable board material, which on opening of the lid reveals an upstanding rim around which side regions of the lid bear as the latter is reclosed. The rigid inner receptacle can contain a plastics bag in which the packaged contents are stored for use as required.

Handle openings can be provided in the carton walls below the level of the tear strip and suitably, in the case of a right parallelepipedic carton, it is the two walls adjacent to the wall providing the reinforced hinge connection which have handle openings. Such handle openings can be reinforced with a further length of reinforcing material applied at the same time as that used for the tear strip.

Where the carton is designed to carry a rigid inner receptacle and a flexible bag within the inner receptacle, should transport regulations dictate no access to the bag via the handle openings, the inner receptacle can provide a barrier preventing finger contact with the bag through the openings provided for carrying the carton.

A particularly preferred form of rigid inner receptacle has three superimposed layers of board material lining each carton wall provided with a handle opening, the two outermost layers of which have handle openings coinciding with the respective handle opening in the carton wall, but the innermost layer of which has no such opening and protects the bag from contact by a hand using the aligned handle openings to carry the carton.

Other desirable features of the invention will become clear from a study of the accompanying drawings which, by way of example, illustrate three embodiments of cartons and blanks in accordance with the invention.

### Brief Description of the Drawings

In the drawings:

Figures 1 and 2 show respectively a one-piece blank for erecting into the outer casing of a lidded carton

and a one-piece blank for a rigid inner receptacle for the casing,

Figures 3 and 4 show the carton created from the blanks of Figures 1 and 2 in its two use formats,

Figure 5 shows a one-piece blank for erecting into a lined lidded carton. Figures 6 and 7 show the carton made from the blank of

Figure 5 in its two use formats,

Figures 8 and 9 show two blanks for erecting into a further lidded carton,

Figures 10 and 11 show the carton made from the blanks of Figures 8 and 9 in its two use formats,

Figure 12 shows a scrap view, on an enlarged scale, of a tear strip and the reinforcing residues it leaves after activation, and

Figure 13 shows a scrap view of a rim region of the carton of Figure 4 showing one form of clip that can be used as a closure for the opened carton.

#### Description of Preferred Embodiments

The one-piece blank 10 of Figure 1 is shown from the inside and is intended to provide the outer casing of a carton. It is cut and creased from a sheet of double-faced corrugated paperboard (the flutes of the central corrugated ply running in the direction of the arrows A) to exhibit external side wall panels 11, 12, 13 and 14, each provided with top flaps 11a to 14a and bottom flaps 11b to 14b. The wall panels are delimited by creases 15, 16 and 17 extending in the flute direction and the flaps are delimited by other creases (unnumbered) extending normal thereto. A narrow gluing tab 14c is formed as an extension of panel 14. Carrying holes (or precursors thereof) 18 are provided in the wall panels 11 and 13.

Figure 2 shows (from the inside) the blank 10a for a rigid inner receptacle for the casing erected from the blank 10 of Figure 1. Again the preferred board material is double-faced corrugated paperboard and the arrows A indicate the direction in which the flutes of the central corrugated ply run in the board. The blank 10a exhibits a central base panel 19 with outer side wall panels 19a and 19b connected thereto via respective creases 22 and 23 extending parallel to the flute directions A, a left wall panel 20 and a right wall panel 21, linked to the central base panel 19 by respective creases 24 and 25 extending normal to the directions A. Inner sidewall panels 21a and 21b are connected by respective creases 26 and 27 to the wall panel 21 and intermediate sidewall panels 20a and 20b are connected by respective creases 28 and 29 to the wall panel 20. Four further carrying holes 30 are formed one in each of the sidewall

panels 19a, 19b and 20a, 20b. No carrying holes are provided in the inner sidewall panels 21a and 21b.

To erect the rigid inner receptacle from the blank of Figure 2, the six sidewall panels 19a to 21b are bent up through 90° relative to their respective base and wall panels 19 to 21 and then the two outer U-shaped structures so formed are each bent inwardly about respective creases 24 and 25. The three creases 22, 26 and 28 and the three creases 23, 27 and 29 are staggered one with respect to the others to allow the three U-shaped structures to combine to form an open-topped right parallelepipedic carton liner having three thicknesses of blank material on two opposite edges of the base panel 19 and a single thickness of blank material (i.e. the left and right wall panels 20 and 21) on the other two opposite edges of the base panel 19.

The folding arrangement described leaves two carrying holes 30 aligned in each of the triple thickness sidewalls but since the sidewall panels 21a and 21b of these triple thickness walls are innermost in the inner receptacle, the holes 30 do not extend completely through the sidewalls of the inner receptacle.

Extending throughout all four wall panels 11 to 14 of blank 10 are lengths of reinforcing material 3 which terminate in panel 11 in a tab 31. In practice, the preferred material 3 is made up of an 11 mm wide strip of "Sesame" tape located between the outer facing sheet of the board material and the corrugated ply and an 11 mm wide strip located on the face of the inner facing sheet which faces away from the corrugated ply to lie symmetrically behind the first mentioned strip. The material 3 (i.e. both tapes) is severed by a cut 32 formed in crease 17 but is continuous between tab 31 and cut 32. The tab 31 diagonally severs all but a narrow central strip of both tapes (e.g. a 3 mm wide strip) whereby pulling on the tab 31 starts a longitudinal tear in both tapes which results in the central part of each tape and the board material sandwiched between such central parts being removed from the blank (see also Figure 12).

To assemble the lined lidded carton from the two blanks 10 and 10a, blank 10a is erected into the inner receptacle as described above and this is located open-top up inside the tube erected from blank 10 when gluing tab 14a is secured to the outer edge of panel 11 and the bottom flaps 11b to 14b are folded in and secured together in conventional manner.

The carton is now ready to receive the contents to be packaged therein and these are disposed in the inner receptacle either directly or after locating a flexible bag (e.g. of plastics material) within the receptacle. After adding the required volume of contents (and closing the bag if such is being used) the top flaps 11a to 14a are secured together to close the carton.

Figure 3 shows the blank 10 of Figure 1 and the blank 10a of Figure 2 erected into a closed carton 35. This is the format in which it would be passed to the end user.

Figure 4 shows the carton 35 in its other format ready for use. Pulling on the tab 31 causes the reinforcing

material 3 to tear open the carton around three of the four sides as far as the cut 32. This action divides the carton into a base 36 and a lid 37 hinged about line 34.

Since only narrow central regions of the two strips of tape forming the reinforcing material are torn away when the tear strip is actuated, the tape widths left adhering to the material of blank 10 on either side of the removed central regions provide reinforcement on each side of the tear. One of these sides represents the three edges of the lid 37 and this reinforcement is valuable in resisting wear and tear on the edges of the lid as they rub against the upper extremity of the inner receptacle when the lid 37 is hinged open or hinged back into its closed condition. Since the contents packaged may well be used in small amounts on many different occasions, reinforcement of the lid edges is a valuable advantage which results from the invention. A further advantage is that the line of the hinge in panel 14 is reinforced by the unused lengths of the reinforcing material 3. The hinge line 34 can be defined by a line of perforations (sometimes known as a "matrix bend") to improve flexibility in this region, the residues of the reinforcing material retaining full integrity of the board material despite the weakening effect of such perforations.

With the inner receptacle located in the carton, each hand hole available in panels 11 and 13 consists of one hole 18 and two holes 30 providing three wall thicknesses to accept the carrying load on each side of the carton. The holes 18, 30, 30 however do not extend to the interior of the inner receptacle (by virtue of the unapertured sidewall panels 21a and 21b) thus meeting the requirement for bagged transport of certain "dangerous goods" that hand contact with the bag must not occur. The unapertured sidewall panels 21a and 21b also allow packaging of particulate materials without an inner bag.

For certain applications (e.g. where a bulky but low density material is to be packaged) it will be possible to use an inner receptacle of much lighter construction than that shown in Figure 2 and in some applications it may even be possible to dispense with an inner receptacle altogether. If the handle openings require reinforcement this can be provided with a further length of reinforcing tape (e.g. as shown in chain lines at 33 in Figure 1).

Figures 5, 6 and 7 illustrate a second embodiment of carton according to this invention. For ease of understanding the many areas of similarity between the first embodiment, similar reference numerals with the addition of 100 will be used to indicate similar integers and the description will be restricted to the areas of difference.

In blank 110, wall panel 112 has the precursor of a lid closure tongue 50 formed therein and two tabs 131a and 131b flank this. The cut 132 is formed between panels 113 and 114 on the crease line 117. The internal wall panels 119, 120 and 121 are connected to blank 110 and lack top and bottom flaps, but panel 120 includes a slot 51 (cut through the lengths of reinforcing material 130) to receive the tongue 50 in the second format of the carton.

Figure 6 shows the carton 55 erected from the blank 110 of Figure 5 (e.g. to receive photographic materials in sheet form). Figure 7 shows the format change available when the tabs 131a and 131b are pulled to activate tear strips to left and right of the tongue 50. The cut 132 stops the tear at the right-hand back corner of the carton 55 leaving a lid 53 hinged to a carton base 54, the hinge line occurring along the (unused) lengths of material 130 which thus reinforces the hinge. After first opening, the lid 53 can be reclosed by locating the tongue 50 in the slot 51. The lengths of reinforcing material 130 extending between the tabs 131a and 131b acts to reinforce a central region of the tongue 50. The residues of the tear strip left around the lid reinforce this edge against wear and tear as previously described.

Figures 8 to 11 show a third embodiment of blank and carton according to this invention and for the description of this embodiment, the reference numerals of Figures 1 and 2 with the addition of "200" will be used for equivalent integers. Figure 8 shows the outer blank 210 of a double-walled heavy-duty powder case (of 72 litres capacity), the inner blank 210A being shown in Figure 9.

The outer blank 210 has the tear strip reinforcing material 230, the cut 232 being formed on crease 215 between panels 211 and 212. The blank 210A has four rectangular inner wall panels 219 to 221 and 63, an edge connecting panel 64 being provided to link panels 63 to 219.

Figure 10 shows a carton 60 in its first format, erected by locating the blank of Figure 9 inside the blank of Figure 8 and folding over the top and bottom flaps 211a to 214a and 211b to 214b.

Figure 11 shows the carton 60 in its second format, created by using the tear strip through pulling on tab 231. The unused tear strip reinforcing material 230 reinforces the hinge of the lid 61 on the base 62 of the carton and residues of the torn lengths of tear strip reinforce the edges of the lid protecting the same against abrasion caused by repeated opening and closing of the lid 61 on the base 62.

Although the use of 3-ply corrugated paperboard material is preferred, it is not the only material that can be used in the exercise of this invention.

Figure 12 shows a section of 3-ply corrugated board material 70 being severed by a tear strip 71. The tear strip 71 is created in the manner described above by applying an inner strip 72 and an outer strip 73 of longitudinally tearable, tape material, respectively, to the concealed surface of the outer ply 74 and the exposed surface of the inner ply 75. The tab 76 is cut diagonally along lines 77a and 77b to leave a central region of both tape strips 72, 73 unweakened by the cut lines 77a, 77b and it is this central region of both tapes which creates the narrow tear strip 71.

As the tear strip is pulled through the board material all three plies are severed cleanly but the two uncorrugated plies (74, 75) are left with the residues of the tape

strips adhering thereto on either side of the material removed to form the tear strip.

As Figure 12 shows, the residues 78a and 78b on ply 75 are exposed and give wear-resistance to the board material (e.g. around the lower edge of the lid 61).

In place of two strips of longitudinally tearable tape of similar width, the inner strip can be narrower than the outer and need not then be longitudinally tearable. A single length of reinforcing tear strip material can also be used and if this is partially severed by the cuts defining the narrow end of the tear tab 31, 131, 231, it would still leave reinforcing material around the edge regions of the lid.

Figure 13 shows a two-part clasp 70 fitted to provide means to securely reclose the carton of Figure 4 after first opening. The clasp 70 can be housed within the carton 35 in the first use format shown in Figure 3 (e.g. on top of a bag containing the packaged product) whereupon the user can remove it on opening and secure one part 70a to the lid 37 and the other part 70b to the base 36. The clasp 70 can take many forms e.g. it could be a lockable catch of metal or plastics material (such as used on a briefcase or suitcase) or a simple snap fastener of the kind illustrated in Figure 13.

The two parts of the clasp 70 can be snapped into pre-formed apertures provided in the blank 10, 110, 210 and such locating features are illustrated schematically by the dotted lines 71, 72 in Figure 1. For a more secure fixing, the clasp parts 70a, 70b can have wing nuts or the like screw fastening devices to clamp the parts in place. A single clasp 70 is usually sufficient but if required (e.g. to ensure opening of the carton requires the use of two different keys) more than one clasp can be provided in the closed carton and more than one set of precursors for the locating position of the clamps provided on the blank.

## Claims

1. A carton (35:55:60) formed from stiff but foldable board material having at least one length of reinforcing material (3, 130, 230) applied to the board material to define an easy-open tear strip (71) delimiting first (36:53:61) and second (37:54:62) carton parts which parts are hingedly connected following use of the tear strip, characterised in that said at least one length of reinforcing material (3, 130, 230) is longitudinally splittable and is cut through along a line (32:132:232) transverse to its longitudinal direction, whereby on use of the tear strip (71), the line of cut (32:132:232) represents the end of the tear, a split length of at least one of the torn lengths up to the line of cut (32:132:232) providing edge reinforcement on at least one of the parts.
2. A carton (35:55:60) as claimed in claim 1, characterised in that the residue of the said at least one length (3, 130, 230) serves as reinforcement for the hinge connection (34) of the two parts.
3. A carton as claimed in claim 1, or claim 2, characterised in that the board material is double-faced corrugated board (70) having outer facing plies (74, 75) and an inner corrugated ply and a tape (72, 73) of reinforcing material is applied to each facing ply whereby use of the tear strip (71) removes a part of each tape from the board material.
4. A carton as claimed in any preceding claim, characterised in that it is in the form of a fully closed parallelepipedic carton (35) containing a rigid inner receptacle also erected from stiff but foldable board material (20) housing packaged contents and which, when opened, leaves a lid (37) hinged to one wall (14) of the carton (35) for easy reclosing and access to the packaged contents via the openable lid (37), the inner receptacle providing an upstanding rim around which side regions of the lid (37) bear as the latter is reclosed.
5. A carton as claimed in claim 4, characterised in that handle openings (18) are provided below the level of the tear strip in the two walls (11, 13) adjacent to the wall (14) providing the hinge connection (34), the rigid inner receptacle containing a plastics bag in which the packaged contents are stored for use as required and in which the liner provides a barrier preventing finger contact with the bag through the openings (18, 30) provided for carrying the carton.
6. A carton as claimed in claim 4 or claim 5, characterised in that the rigid inner receptacle has at least two superimposed layers of board material (20) lining each carton wall provided with a handle opening (18), the outermost layers of which have handle openings (30) coinciding with the respective handle openings (18) in the carton wall, but the innermost layers of which have no such openings.
7. A carton as claimed in any preceding claim, characterised in that a clasp (70) for securing the carton parts (36, 37) together after actuation of the tear strip is housed in the carton, the clasp having one part (70a) securable to the lid (37) and one part (70b) securable to the body (36), each part (70a, 70b) being locatable in a feature provided in the board material.
8. A one piece blank (10, 110, 210) of stiff but foldable board material designed to be erected into a carton (35:55:60) whose format can be changed by use of a tear strip (71) to leave a carton base (36:54:62) with a hinged lid (37:53:61), said blank (10, 110, 210) including at least one length of reinforcing material (3, 130, 230) applied to the board material to reinforce the tear strip, characterised in that said at least one length of reinforcing material is longitudinally splittable and extends from side to side of the blank but its use as a tear strip is limited to part only

of its length by virtue of at least one cut (32:132:232) in the board material which extends transversely across the at least one length intermediate its ends and the torn length provides reinforcement for edges of the lid (37:53:61).

9. A blank as claimed in claim 8, characterised in that the reinforcing material is a fibre-based tape that incorporates a heat-sensitive adhesive, one length (73) of the tape being located on the inside face (75) of the board material (70) and the residue of the length(s) of reinforcing material (73) beyond the said cut serving as a hinge reinforcement for the lid.
10. A blank as claimed in claim 8, or claim 9, characterised in that a further length of reinforcing material is provided above handle openings in the blank.

### Patentansprüche

1. Schachtel (35:55:60), die aus steifem, aber faltbarem Kartonmaterial geformt ist und zumindest eine am Kartonmaterial angebrachte Länge aus Verstärkungsmaterial (3, 130, 230) besitzt, um somit ein leicht zu öffnendes Reißband (71) zu definieren, das erste (36:53:61) und zweite (37:54:62) Schachtelteile begrenzt, die nach Benutzung des Reißbandes schwenkbar miteinander verbunden sind, dadurch gekennzeichnet, daß die genannte zumindest eine Länge aus Verstärkungsmaterial (3, 130, 230) in Längsrichtung auftrennbar und entlang einer quer zu ihrer Längsrichtung verlaufenden Linie (32:132:232) durchgeschnitten ist, so daß die Schnittlinie (32:132:232) bei Benutzung des Reißbandes (71) das Ende der Auftrennung darstellt, wobei eine Teillänge von zumindest einer der Reißlängen bis zur Schnittlinie (32:132:232) als Kantenverstärkung an zumindest einem der Teile dient.
2. Schachtel (35:55:60) nach Anspruch 1, dadurch gekennzeichnet, daß der Rest der genannten zumindest einen Länge (3, 130, 230) als Verstärkung für die Schwenkverbindung (34) der beiden Teile dient.
3. Schachtel nach Anspruch 1 oder Anspruch 2, dadurch gekennzeichnet, daß es sich bei dem Kartonmaterial um doppelseitigen gewellten Karton (70) mit Außenschichten (74, 75) und einer innenliegenden gewellten Schicht handelt und ein Streifen (72, 73) aus Verstärkungsmaterial an jeder Außenschicht angebracht ist, so daß bei Benutzung des Reißbandes (71) ein Teil eines jeden Streifens vom Kartonmaterial entfernt wird.
4. Schachtel nach einem der vorstehenden Ansprüche, dadurch gekennzeichnet, daß es sich um eine vollständig geschlossene parallele flache Schachtel (35) handelt, die ein starres inneres Behältnis enthält, das ebenfalls aus steifem, aber faltbarem Kartonmaterial (20) zur Unterbringung des Verpackungsinhaltes errichtet ist, und bei der nach erfolgter Öffnung ein schwenkbarer Deckel (37) an einer Wand (14) der Schachtel (35) verbleibt, so daß die Schachtel wieder problemlos verschlossen werden kann und über den Deckel (37), der sich öffnen läßt, ein leichter Zugang zum Verpackungsinhalt möglich ist, wobei das innere Behältnis einen aufrechten Rand bildet, um den herum Seitenbereiche des Deckels (37) aufliegen, wenn der Deckel erneut geschlossen wird.
5. Schachtel nach Anspruch 4, dadurch gekennzeichnet, daß Trageöffnungen (18) unterhalb der Höhe des Reißbandes in den beiden Wänden (11, 13) angeordnet sind, die an die Wand (14), in der die Schwenkverbindung (34) vorgesehen ist, angrenzen, wobei das starre innere Behältnis einen Kunststoffbeutel enthält, in dem der Verpackungsinhalt für eine Verwendung nach Bedarf gelagert wird und der Innenbeutel als Sperre dafür sorgt, daß Fingerkontakt mit dem Beutel durch die für das Tragen der Schachtel vorgesehenen Öffnungen (18, 30) verhindert wird.
6. Schachtel nach Anspruch 4 oder Anspruch 5, dadurch gekennzeichnet, daß das starre innere Behältnis zumindest zwei übereinanderliegende Schichten aus Kartonmaterial (20) aufweist, mit dem jede mit einer Trageöffnung (18) versehene Schachtelwand ausgekleidet ist, wobei seine äußersten Schichten Trageöffnungen (30) besitzen, die mit den entsprechenden Trageöffnungen (18) in der Schachtelwand zusammenfallen, seine innersten Schichten jedoch keine solchen Öffnungen aufweisen.
7. Schachtel nach einem der vorstehenden Ansprüche, dadurch gekennzeichnet, daß eine Klammer (70), mit der die Schachtelteile (36, 37) nach Betätigung des Reißbandes zusammengehalten werden, in der Schachtel untergebracht ist, wobei die Klammer ein am Deckel (37) sicheres Teil (70a) und ein am Körper (36) sicheres Teil (70b) aufweist und jedes Teil (70a, 70b) in einem im Kartonmaterial vorgesehenen Merkmal angeordnet werden kann.
8. Einteiliger Zuschnitt (10, 110, 210) aus steifem, aber faltbarem Kartonmaterial, der so ausgelegt ist, daß sich daraus eine Schachtel (35:55:60) errichten läßt, deren Format durch Benutzung eines Reißbandes (71) so verändert werden kann, daß ein Schachtelunterteil (36:54:62) mit einem Schwenkdeckel (37:53:61) verbleibt, wobei der genannte Zuschnitt (10, 110, 210) zumindest eine am Kartonmaterial angebrachte Länge aus Verstärkungsmaterial (3,

130, 230) einschließt, um das Reißband zu verstärken, dadurch gekennzeichnet, daß die genannte zumindest eine Länge aus Verstärkungsmaterial in Längsrichtung auftrennbar ist und von einer Seite des Zuschnittes zu seiner anderen Seite verläuft, wobei jedoch ihre Verwendung als Reißband auf- und zumindest eines Schnittes (32:132:232) im Kartonmaterial, der quer über die zumindest eine Länge zwischen ihren Enden verläuft, auf nur einen Teil ihrer Länge begrenzt ist und die Reißlänge als Verstärkung für Kanten des Deckels (37:53:61) dient.

9. Zuschnitt nach Anspruch 8, dadurch gekennzeichnet, daß es sich bei dem Verstärkungsmaterial um einen einen wärmeempfindlichen Kleber enthaltenden Streifen auf Faserbasis handelt, wobei eine Länge (73) des Streifens auf der inneren Stirnfläche (75) des Kartonmaterials (70) angeordnet ist und der Rest der über den genannten Schnitt hinausgehenden Länge(n) des Verstärkungsmaterials (73) als Schwenkverstärkung für den Deckel dient.
10. Zuschnitt nach Anspruch 8 oder Anspruch 9, dadurch gekennzeichnet, daß eine weitere Länge aus Verstärkungsmaterial oberhalb von Trageöffnungen im Zuschnitt vorgesehen ist.

#### Revendications

1. Boîte en carton (35; 55; 60) formée de matériau de carton rigide mais pliable ayant au moins une longueur de matériau de renfort (3, 130, 230) appliquée sur le matériau de carton pour définir une bande de déchirure (71) pour ouverture facile délimitant des première (36; 53; 61) et seconde (37; 54; 62) parties de la boîte en carton, lesquelles parties sont connectées avec articulation après l'utilisation de la bande de déchirure, caractérisée en ce que ladite au moins une longueur de matériau de renfort (3, 130, 230) peut être fendue dans le sens longitudinal et est découpée le long d'une ligne (32; 132; 232) transversale à sa direction longitudinale, grâce à quoi, lors de l'utilisation de la bande de déchirure (71), la ligne de coupe (32; 132; 232) représente l'extrémité de la déchirure, une longueur fendue d'au moins une des longueurs déchirées jusqu'à la ligne de coupe (32; 132; 232) fournissant un renfort des bords sur au moins l'une des parties.
2. Boîte en carton (35; 55; 60) selon la revendication 1, caractérisée en ce que le résidu de ladite au moins une longueur (3, 130, 230) sert de renfort pour la connexion articulée (34) des deux parties.
3. Boîte en carton selon la revendication 1 ou la revendication 2, caractérisée en ce que le matériau de carton est du carton ondulé double face (70) ayant des couches tournées vers l'extérieur (74, 75) et une couche ondulée interne et un ruban (72, 73) de matériau de renfort est appliqué à chaque couche tournée vers l'extérieur, l'utilisation de la bande de déchirure (71) enlevant par ce biais une partie de chaque ruban du matériau de carton.
4. Boîte en carton selon l'une quelconque des revendications précédentes, caractérisée en ce qu'elle se présente sous la forme d'une boîte en carton (35) parallélépipédique entièrement fermée, contenant un réceptacle interne rigide également érigé à partir d'un matériau de carton (20) rigide mais pliable renfermant un contenu emballé et qui, une fois ouvert, laisse un couvercle (37) articulé à une paroi (14) de la boîte en carton (35) pour pouvoir être facilement refermé et pour pouvoir accéder facilement au contenu emballé par l'intermédiaire du couvercle ouvrable (37), le réceptacle interne fournissant un rebord vertical autour duquel les régions latérales du couvercle (37) reposent lorsque ce dernier est refermé.
5. Boîte en carton selon la revendication 4, caractérisée en ce que des ouvertures de poignée (18) sont prévues en-dessous du niveau de la bande de déchirure dans les deux parois (11, 13) adjacentes à la paroi (14) fournissant la connexion articulée (34), le réceptacle interne rigide contenant un sac en plastique dans lequel le contenu emballé est stocké pour une utilisation selon les besoins, et dans lequel la doublure fournit une barrière contre le contact des doigts avec le sac à travers les ouvertures (18, 30) prévues pour porter la boîte en carton.
6. Boîte en carton selon la revendication 4 ou la revendication 5, caractérisée en ce que le réceptacle interne rigide a au moins deux couches superposées de matériau de carton (20) doublant chaque paroi de la boîte en carton pourvue d'une ouverture de poignée (18), dont les couches les plus externes ont des ouvertures de poignée (30) coïncidant avec les ouvertures de poignée (18) respectives dans la paroi de la boîte en carton, mais dont les couches les plus internes n'ont pas de telles ouvertures.
7. Boîte en carton selon l'une quelconque des revendications précédentes, caractérisée en ce qu'un fermoir (70) pour fixer les parties de la boîte en carton (36, 37) ensemble après l'activation de la bande de déchirure est logé dans la boîte en carton, le fermoir ayant une partie (70a) pouvant être fixée au couvercle (37) et une partie (70b) pouvant être fixée au corps (36), chaque partie (70a, 70b) pouvant être située dans un élément prévu dans le matériau de carton.
8. Pièce de carton d'une seule pièce (10, 110, 210) en matériau de carton rigide mais pliable conçue pour être érigée pour former une boîte en carton (35; 55; 60) dont le format peut être modifié en utilisant une bande de déchirure (71) pour laisser une base de

boîte en carton (36; 54; 62) avec un couvercle articulé (37; 53; 61), ladite pièce de carton (10, 110, 210) comportant au moins une longueur de matériau de renfort (3, 130, 230) appliquée contre le matériau de carton pour renforcer la bande de déchirure, caractérisée en ce que ladite au moins une longueur de matériau de renfort peut être fendue longitudinalement et s'étend d'un côté à l'autre de la pièce de carton mais son utilisation en tant que bande de déchirure est limitée à une partie uniquement de sa longueur grâce à au moins une découpe (32; 132; 232) dans le matériau de carton qui s'étend transversalement en travers d'au moins la longueur intermédiaire entre ses extrémités et la longueur déchirée fournit un renfort pour les bords du couvercle (37; 53; 61).

5

10

15

9. Pièce de carton selon la revendication 8, caractérisée en ce que le matériau de renfort est un ruban à base de fibre qui incorpore un adhésif thermosensible, une longueur (73) du ruban étant située sur la face interne (75) du matériau de carton (70) et le résidu de la (des) longueur(s) de matériau de renfort (73) au-delà de ladite découpe servant de renfort d'articulation pour le couvercle.

20

25

10. Pièce de carton selon la revendication 8 ou la revendication 9, caractérisée en ce qu'une longueur supplémentaire de matériau de renfort est prévue au-dessus des ouvertures de poignée dans la pièce de carton.

30

35

40

45

50

55

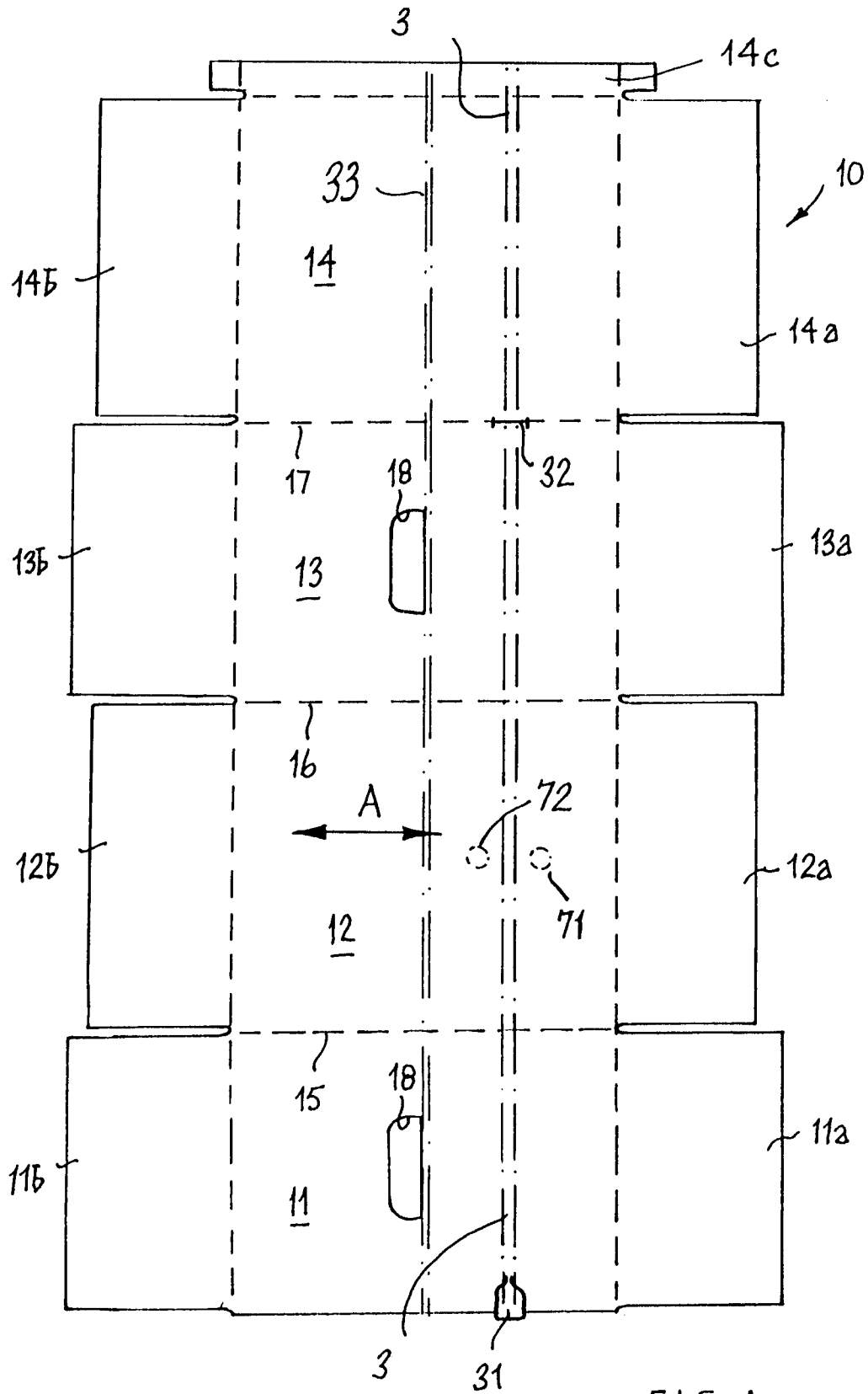
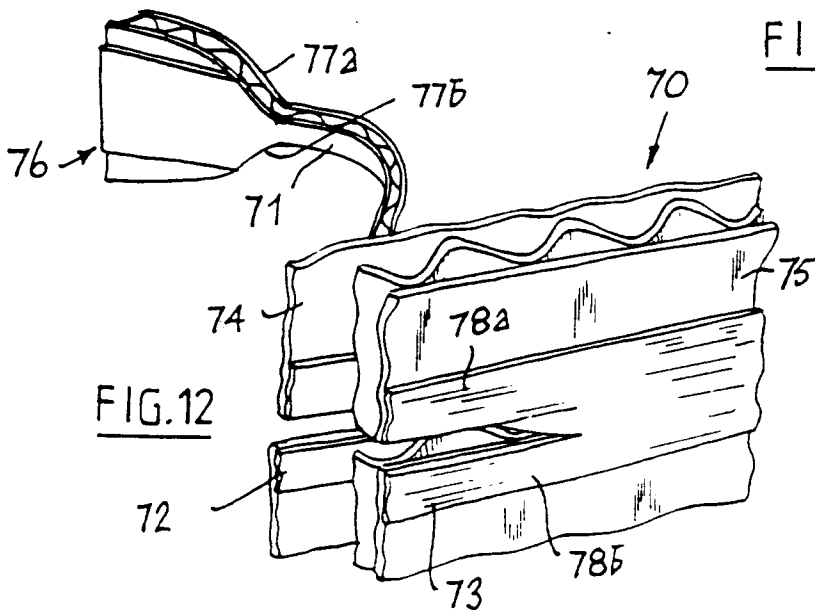
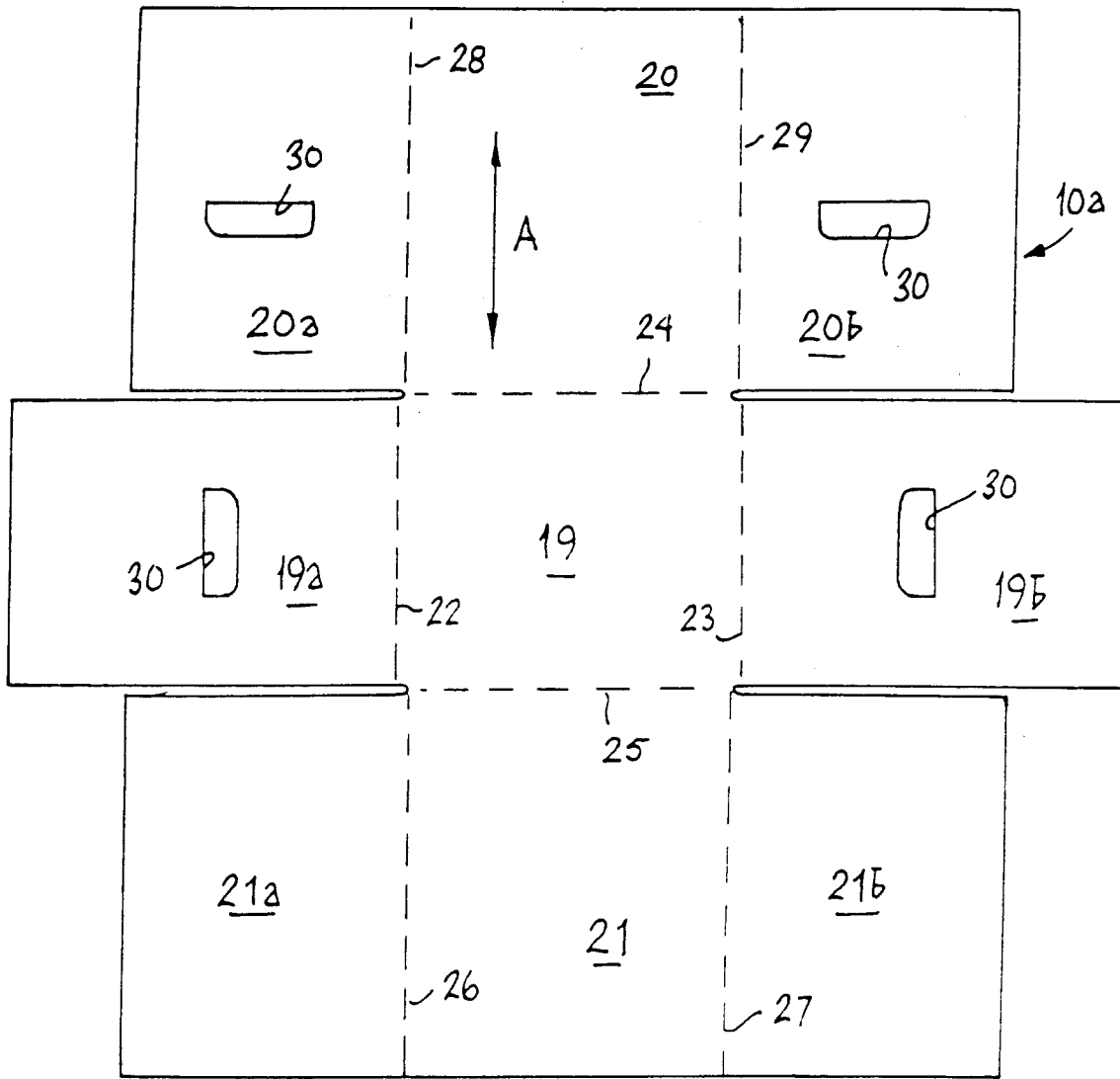
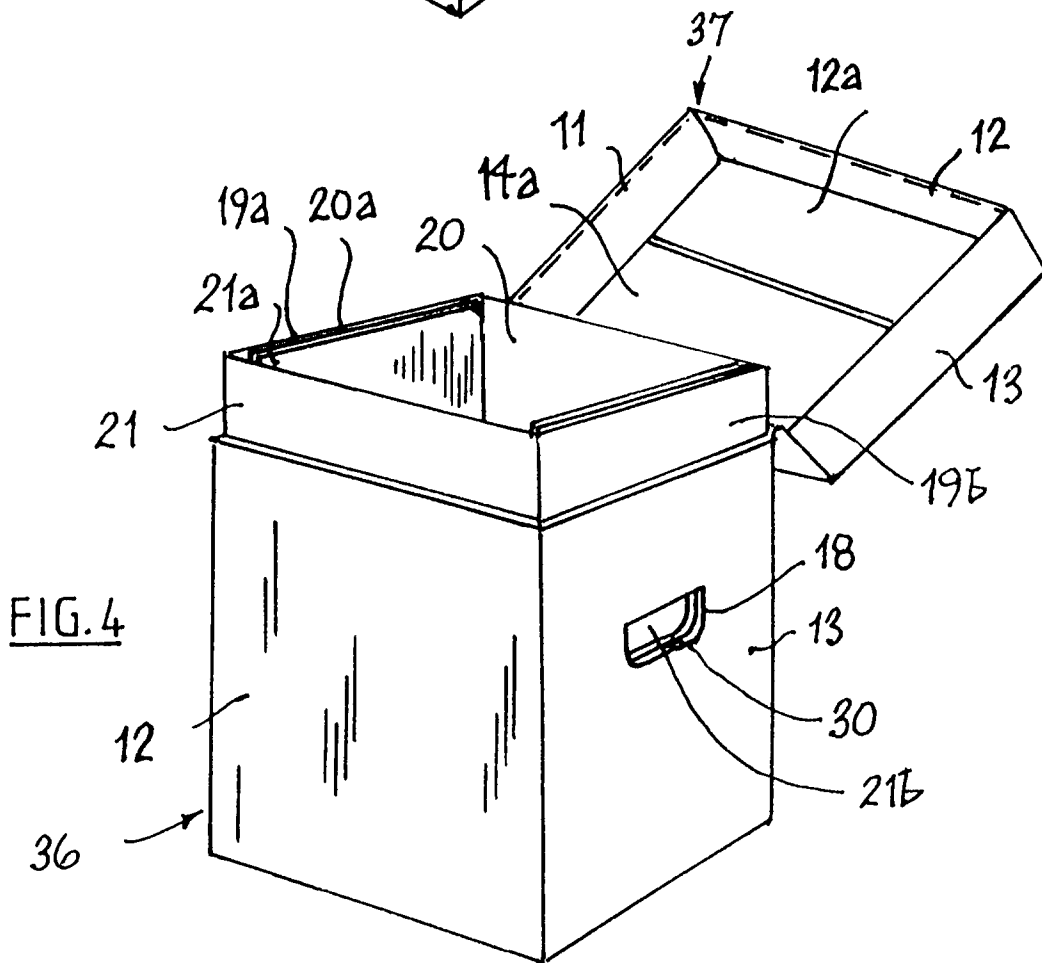
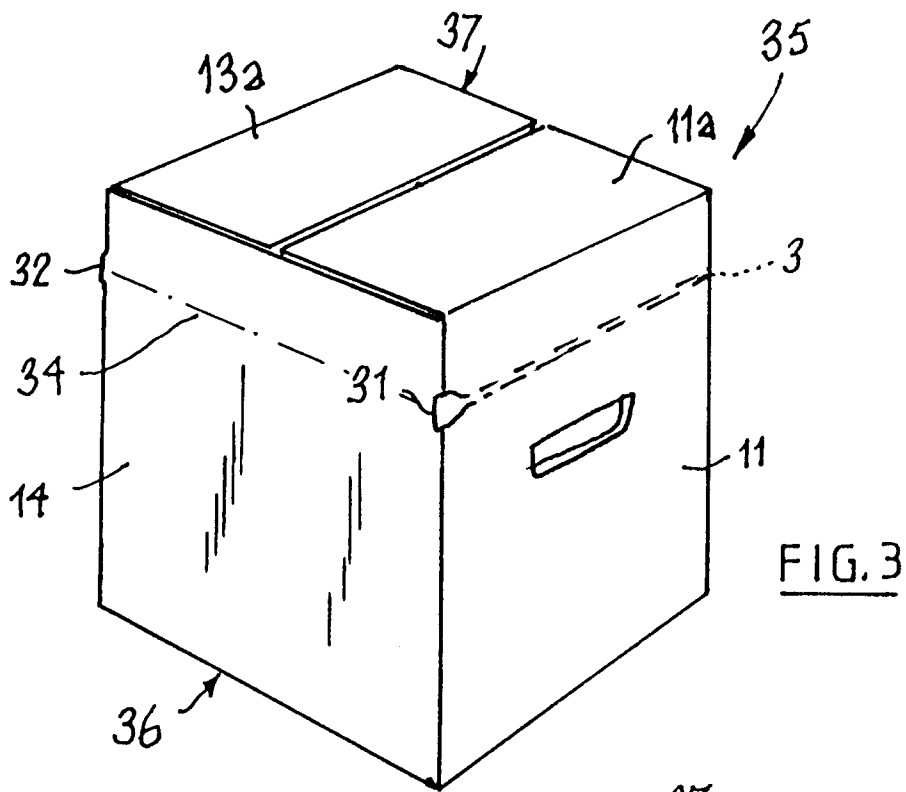

FIG. 1





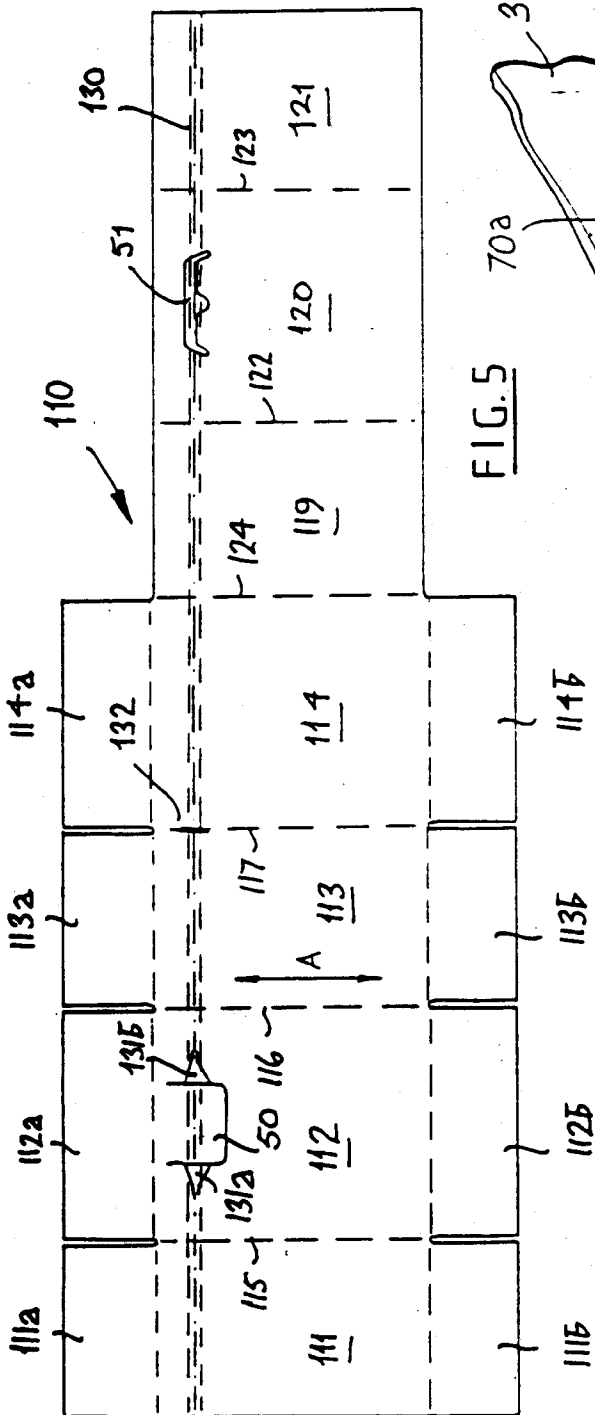

FIG. 5

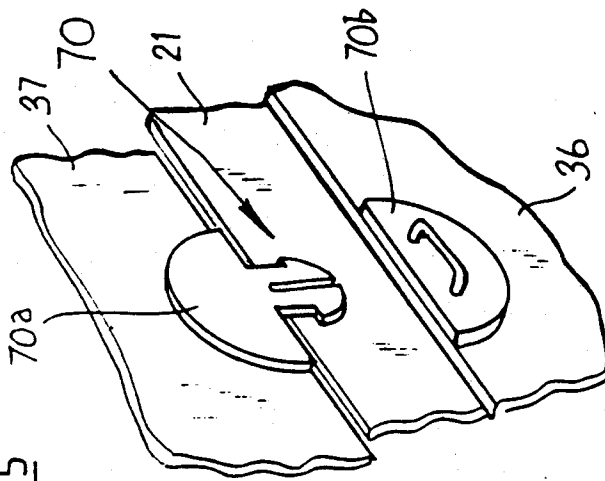

FIG. 13

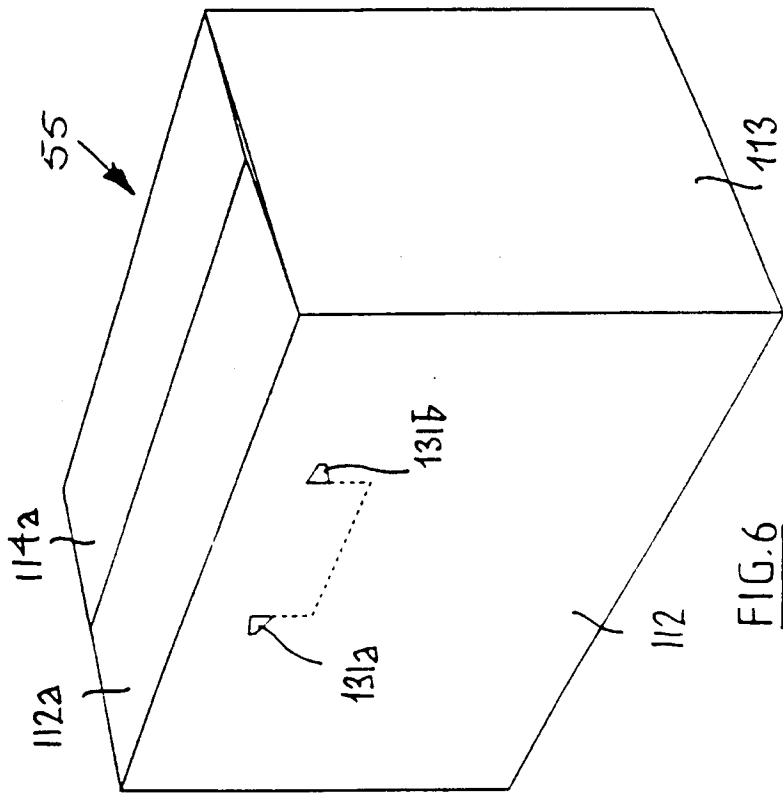

FIG. 6

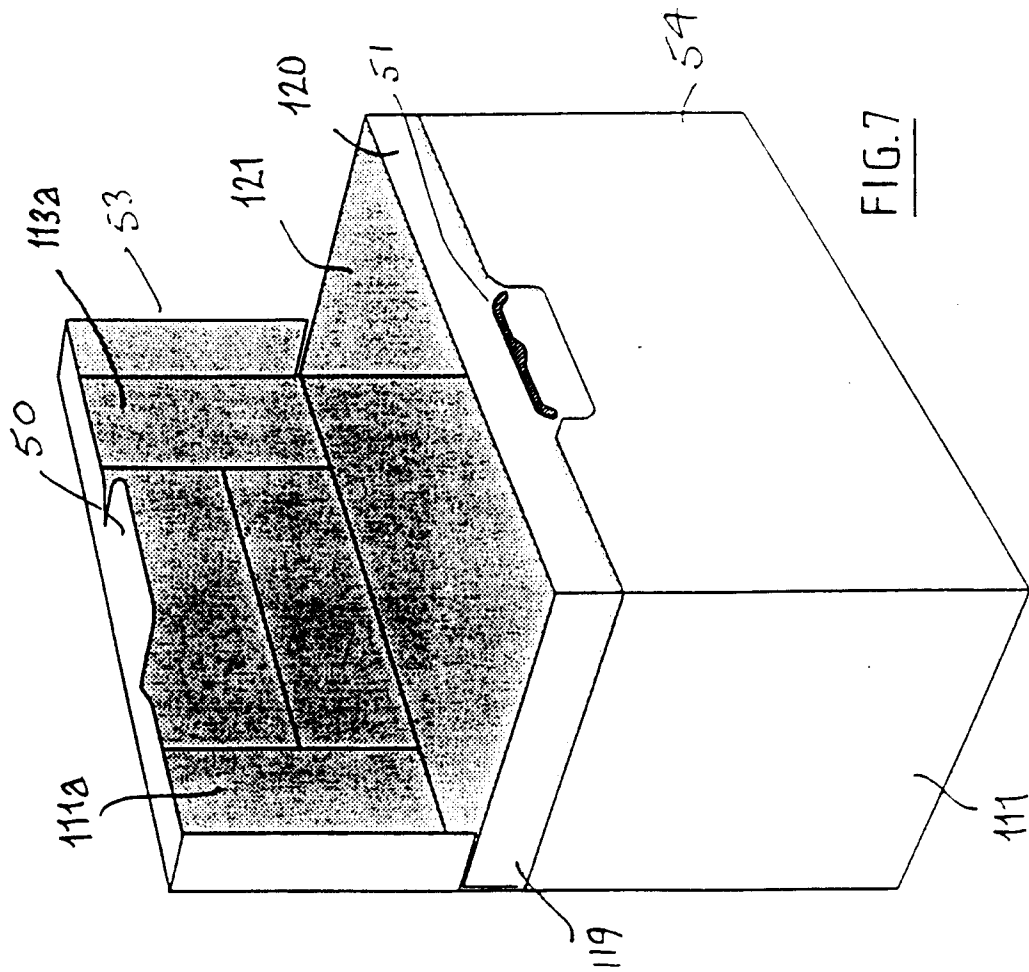

FIG. 7

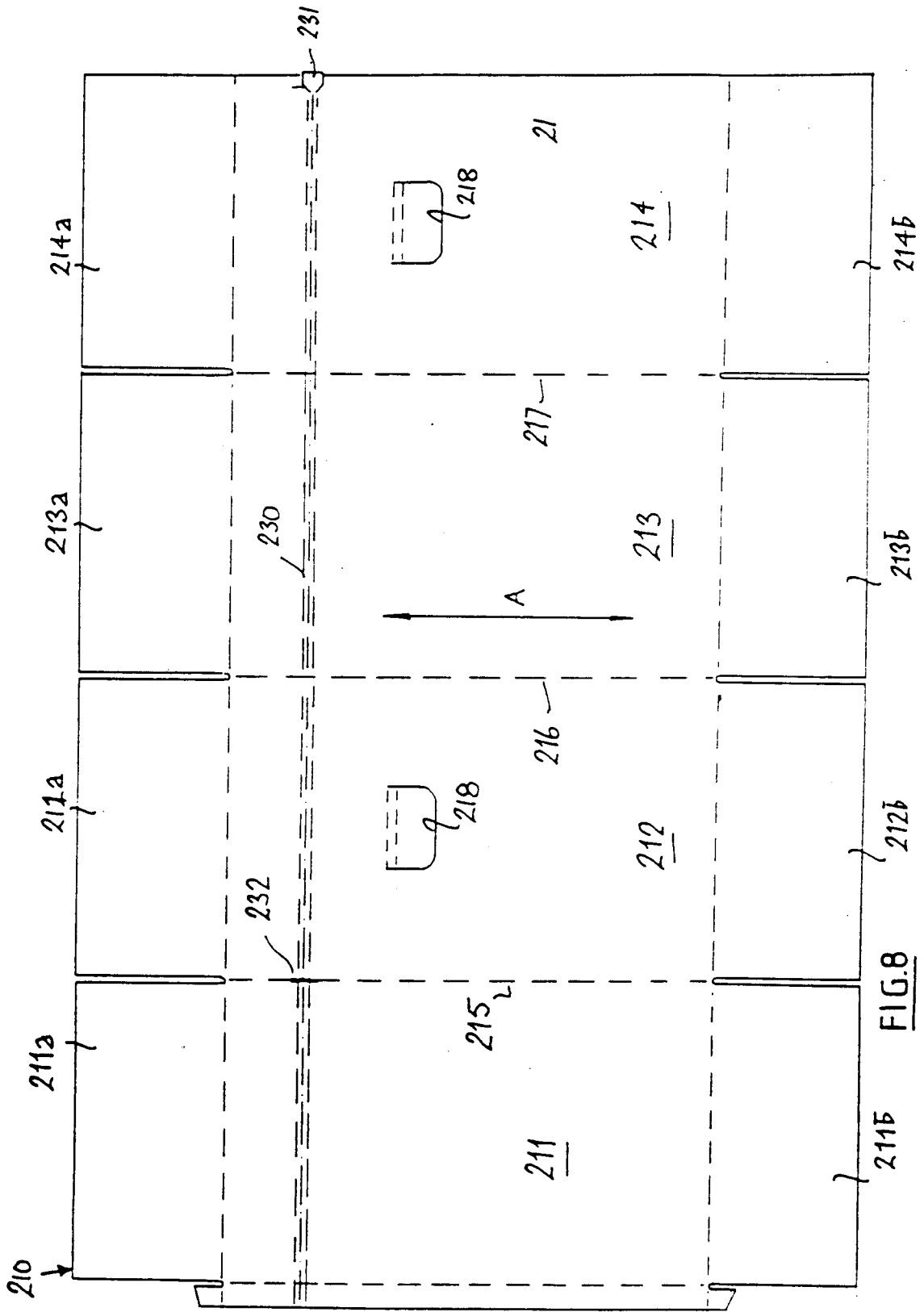

FIG. 8

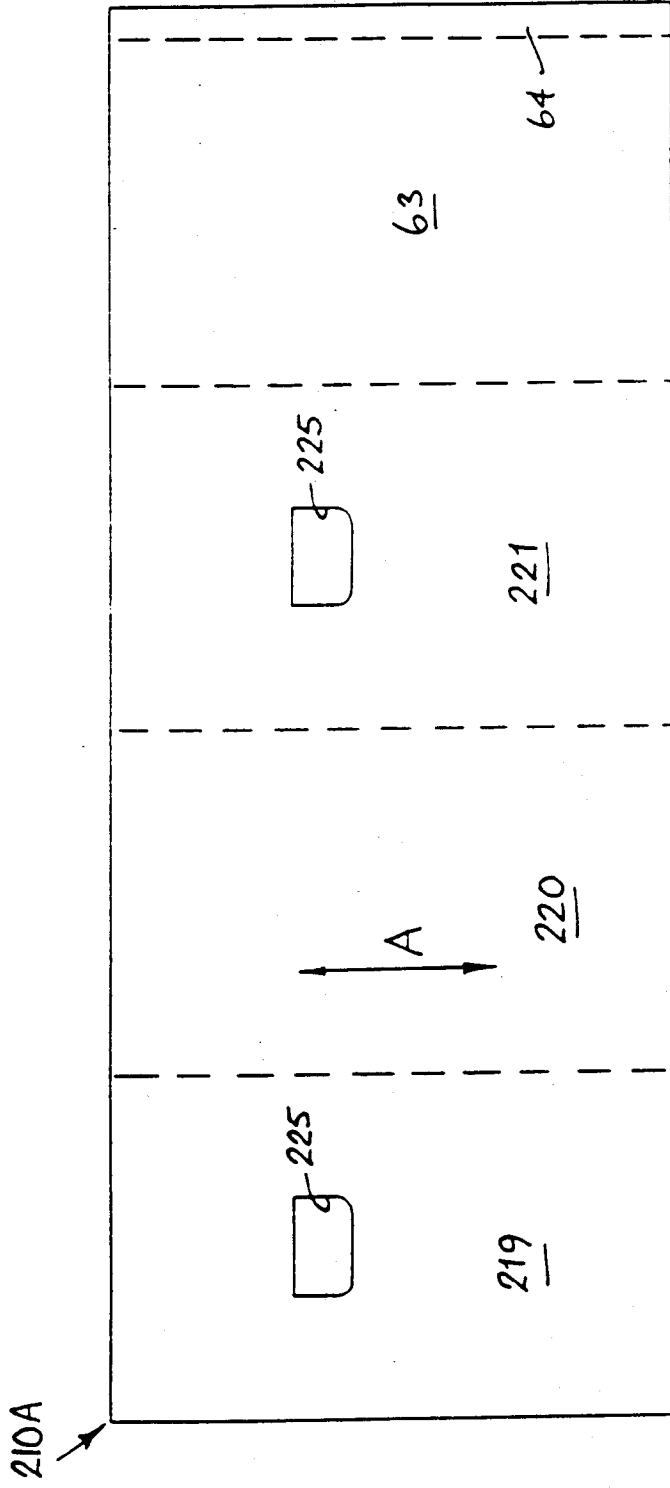

FIG. 9

