

(19) World Intellectual Property Organization
International Bureau



(43) International Publication Date
1 June 2006 (01.06.2006)

PCT

(10) International Publication Number
WO 2006/057676 A1

- (51) International Patent Classification:
G01K 11/00 (2006.01)
- (21) International Application Number:
PCT/US2005/025678
- (22) International Filing Date: 20 July 2005 (20.07.2005)
- (25) Filing Language: English
- (26) Publication Language: English
- (30) Priority Data:
10/995,952 23 November 2004 (23.11.2004) US
- (71) Applicant (for all designated States except US): XY-TRANS, INC. [US/US]; 5422 Carrier Drive, Suite 201, Orlando, Florida 32819 (US).
- (72) Inventor: AMMAR, Danny F.; 7054 Horizon Circle, Windermere, Florida 34786 (US).
- (74) Agents: WARTHER, Richard K. et al.; 255 S. Orange Avenue, Suite 1401, Orlando, Florida 32801 (US).

- (81) Designated States (unless otherwise indicated, for every kind of national protection available): AE, AG, AL, AM, AT, AU, AZ, BA, BB, BG, BR, BW, BY, BZ, CA, CH, CN, CO, CR, CU, CZ, DE, DK, DM, DZ, EC, EE, EG, ES, FI, GB, GD, GE, GH, GM, HR, HU, ID, IL, IN, IS, JP, KE, KG, KM, KP, KR, KZ, LC, LK, LR, LS, LT, LU, LV, MA, MD, MG, MK, MN, MW, MX, MZ, NA, NG, NI, NO, NZ, OM, PG, PH, PL, PT, RO, RU, SC, SD, SE, SG, SK, SL, SM, SY, TJ, TM, TN, TR, TT, TZ, UA, UG, US, UZ, VC, VN, YU, ZA, ZM, ZW.
- (84) Designated States (unless otherwise indicated, for every kind of regional protection available): ARIPO (BW, GH, GM, KE, LS, MW, MZ, NA, SD, SL, SZ, TZ, UG, ZM, ZW), Eurasian (AM, AZ, BY, KG, KZ, MD, RU, TJ, TM), European (AT, BE, BG, CH, CY, CZ, DE, DK, EE, ES, FI, FR, GB, GR, HU, IE, IS, IT, LT, LU, LV, MC, NL, PL, PT, RO, SE, SI, SK, TR), OAPI (BF, BJ, CF, CG, CI, CM, GA, GN, GQ, GW, ML, MR, NE, SN, TD, TG).

Published:
— with international search report

For two-letter codes and other abbreviations, refer to the "Guidance Notes on Codes and Abbreviations" appearing at the beginning of each regular issue of the PCT Gazette.

(54) Title: MULTI-CHANNEL RADIOMETER IMAGING SYSTEM

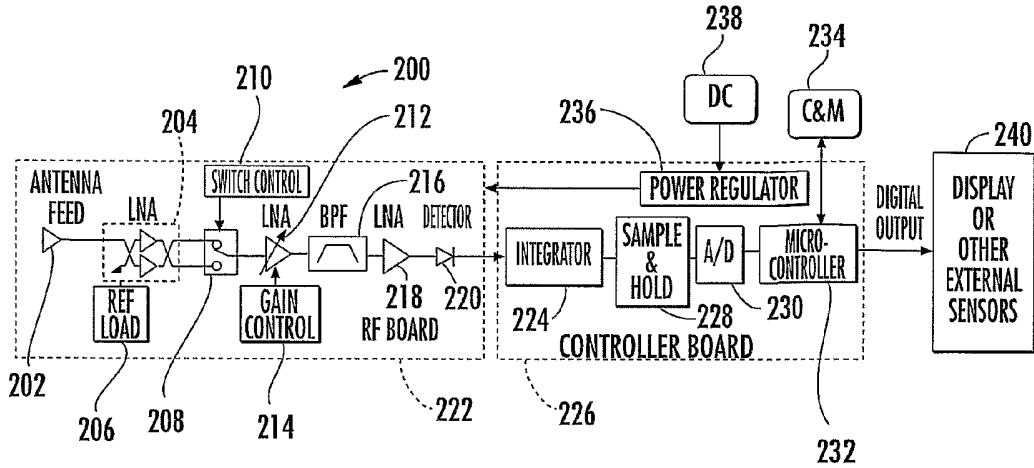

(57) Abstract: The invention relates to a radiometer includes a housing and an RF board carried by the housing. A hybrid and amplifier circuit receives an unknown signal and a known reference signal. A switch receives signals as inputs from the hybrid and amplifier circuit and switches between the inputs. A detection circuit receives and detects the signal from the switch forming a detected signal. A controller board is carried by the housing and an integration circuit and processor receive the detected signal and produces a digital output. The invention also relates to a method of operating a radiometer system.

WO 2006/057676 A1

MULTI-CHANNEL RADIOMETER IMAGING SYSTEM**Field of the Invention**

[0001] The present invention relates to the field of focal plane radiometers, and more particularly, the present invention relates to radiometer systems applicable for use at millimeter wave (MMW) frequencies.

Background of the Invention

[0002] Since radio waves may be considered infrared radiation of long wave, a hot body would be expected to radiate microwave energy thermally. In order to be a good radiator of microwave energy, a body must be a good absorber. The best thermal radiator is a "black body." The amount of radiation emitted in the MMW range is 10^8 times smaller than the amount emitted in the infrared range. Current MMW receivers, however, have at least 10^5 times better noise performance than infrared detectors, and with some temperature contrast, the remaining 10^3 may be recovered. This makes passive MMW imaging comparable in performance with current infrared systems. This unique characteristic makes MMW radiometers a popular choice for sensing thermal radiation. MMW radiometers have been used in many

different applications such as remote terrestrial and extra-terrestrial sensing, medical diagnostics and defense applications. MMW electromagnetic radiation windows occur at 35 GHz, 94 GHz, 140 GHz and 220 GHz. The choice of frequency depends on specific applications.

[0003] Focal plane arrays are used to form images from radiation received by a reflector antenna. Millimeter wave (MMW) focal plane array radiometers also have been used in many applications to form images based on thermal sensing of radiated microwave energy. The sensitivity of existing radiometer designs, however, has been limited to about 1 deg K, resulting in poor images.

[0004] The principle of operation of the radiometric technique is fully described in the literature. The design of a typical radiometer is based on the technique of comparing the level of electromagnetic noise emitted by an unknown source to a reference or stable noise source. This technique and devices were initially proposed by Dicke [R. H. Dicke, "The Measurement of Thermal Radiation at Microwave Frequencies," The Review of Scientific Instruments, Vol. 17, No. 7, July 1946].

[0005] In a Dicke radiometer circuit, the signals from an antenna are sampled and compared with signals from a reference source maintained at a known constant temperature. This overcomes some of the problems of amplifier instability, but in general does not alter effects resulting from imperfect components and thermal gradients.

[0006] While other types of radiometric devices have been used with some success, the Dicke (or comparison) type of radiometer has been the most widely used for

the study of relatively low level noise-like MMW signals, especially where the noise signals to be examined are often small in comparison to the internally generated noise level within the radiometer receiver. While there are several types of comparison radiometers, one popular type of radiometer for use in the microwave/millimeter wave frequency bands is that in which an incoming signal to be measured and a standard or calibrated reference noise signal are compared. This type of radiometer consists essentially of the comparison of the amplitude of an unknown noise signal coming from the source to be examined with a known amplitude of a noise signal from a calibration source. This method has been found useful in measuring with considerable accuracy the effective temperature of an unknown source.

[0007] In the Dicke or comparison type radiometer, the receiver input is switched between the antenna and a local reference signal noise generator. The detected and amplified receiver output is coupled to a phase-sensing detector operated in synchronism with the input switching. The output signal from such a radiometer receiver is proportionate to the difference between the temperature of the reference signal source and the temperature of the source viewed by the antenna inasmuch as the phase-sensing detector acts to subtract the background or internal noise of the receiver.

[0008] A Dicke radiometer uses an RF switch coupled between an antenna and a radiometer receiver, allowing the receiver to alternate between the antenna and a known reference load termination. The receiver output is connected to a synchronous detector that produces an output voltage proportional to a difference between the antenna and the reference temperature. Null balance

operation for the Dicke radiometer has been achieved by coupling in noise from a hot noise diode to the antenna port of the RF switch thereby enabling matching the temperature from standard reference loads.

[0009] The sensitivity of radiometer measurements are also often limited by random gain fluctuations in the RF front end, low frequency noise ($1/f$), and bias in the detector circuits. Over the last decades many special techniques, including Dicke switching, have been implemented to reduce measurement errors. Many of these proposals do not yield a true solution that will allow MMW radiometers to be commercially viable. In addition, the high cost of MMW RF receivers has limited the number of channels in the radiometer to a low number, resulting in a requirement to scan both azimuth and elevation to create an image.

[0010] The invention disclosed in the commonly assigned and incorporated by reference patent application serial number 10/847,892 eliminates the need for a Dicke switch and does not use a synchronizing circuit because it uses the source and reference all the time, and runs the source and reference signal through the amplifiers. It used a balanced channel approach and MMIC chips. Thus, a radiometer channel can be implemented by the use of either a single millimeter wave monolithic integrated circuit (MMIC) or through discrete implementation using printed hybrids and multiple MMIC low noise amplifiers (LNA's).

[0011] This compact radiometer as disclosed can fit directly into the antenna focal plane. A quadrature hybrid network is used in the front end to distribute RF input signals and reference signals to a balanced amplifier chain, thereby reducing gain variations and

improving radiometer sensitivity. A balanced detector diode circuit, for example, a pair of diodes in one non-limiting example, eliminates drift errors introduced by a detector diode as a function of temperature.

[0012] A video signal chopper amplifier circuit, also referred to by some as a auto zero amplifier, eliminates bias introduced by the video amplifier. A near perfect channel-to-channel matching exists through the use of quadrature hybrid network or through digital signal processing corrections. This hybrid radiometer provides improved sensitivity over the Dicke radiometer.

[0013] This radiometer system, however, requires processing of two channels, i.e., the antenna and reference, resulting in higher system complexity and cost. It would be advantageous to provide a radiometer design that could combine features of the different radiometers to achieve low system temperature and low implementation costs.

Summary of the Invention

[0014] The radiometer of the present invention uses a combination of hybrid, low noise amplifiers (LNA's) and a switch to achieve low system temperature and low implementation cost. Unlike a typical Dicke radiometer where the switch losses translate directly into an increase in system noise, such as system temperature, the switch is positioned after a low noise amplifier. This design eliminates the impact of the switch losses. The radiometer of the present invention also combines the benefit of the low noise figure achieved by the hybrid approach and the simple, single channel processing achieved by the Dicke approach.

[0015] In accordance with the present invention, a radiometer system includes a hybrid and amplifier circuit that receives an unknown signal and known reference signal. A switch receives the unknown signal and known reference signal as inputs from the hybrid and amplifier circuit and switches between the signals. A detection circuit receives and detects a signal from the switch forming a detected signal. A controller circuit receives the detected signal and produces a digital output.

[0016] In one aspect of the present invention, the hybrid and amplifier circuit, the switch and the detection circuit comprise a radiometer front end. This radiometer can be sized and of such weight to fit directly into an antenna focal plane. The hybrid and amplifier circuit preferably is formed as printed hybrids and low noise amplifiers. The controller circuit is formed as an integrator circuit. The controller circuit can be formed as an analog-to-digital converter for converting the detected signals to digital signals. This controller circuit can also be formed as a processor that receives the digital signals from the analog-to-digital converter for further processing.

[0017] In yet another aspect of the present invention, the hybrid and amplifier circuit and switch are formed as a MMIC chip. The amplifier circuit receives a signal from the switch before the detection circuit. The amplifier circuit is also formed as a MMIC chip and is formed as two amplifier circuits and a filter circuit between the switch and detection circuit. Each amplifier circuit is also formed as a MMIC chip.

[0018] In yet another aspect of the present invention, the radiometer system includes an RF board having the hybrid and amplifier circuit, switch and detection circuit thereon. A controller board has the controller circuit and is operative with components on the RF board. A housing can carry the RF board and controller board. In one aspect of the present invention, the RF board is preferably formed from a soft board or ceramic material.

Brief Description of the Drawings

[0019] Other objects, features and advantages of the present invention will become apparent from the detailed description of the invention which follows, when considered in light of the accompanying drawings in which:

[0020] FIG. 1 is a fragmentary environmental view of a typical radiometer antenna system for a focal plane array.

[0021] FIG. 2 is a block diagram showing a receiver front end in a typical radiometer system.

[0022] FIG. 2A is a block diagram showing how radiometer modules are typically connected to the antenna with a waveguide manifold in current art.

[0023] FIG. 3 is a block diagram illustrating the basic functional components of the radiometer of the present invention.

[0024] FIG. 3A is a block diagram of the quadrature hybrid used in the radiometer of FIG. 3 showing how inputs A, B are divided equally in the first hybrid, then reconstructed in the second hybrid.

[0025] FIG. 3B is a block diagram showing a two-stage MMIC LNA chip of the present invention as a representative example.

[0026] FIG. 3C is a block diagram showing a three-stage MMIC LNA chip of the present invention.

[0027] FIG. 3D is a block diagram illustrating the basic functional components of the radiometer of the present invention using the MMIC chip of FIG. 3B.

[0028] FIG. 4 is a block diagram showing functional components of another example of a multi-channel radiometer of the present invention.

[0029] FIG. 5 is a block diagram showing the layout for the RF front end in the radiometer of the present invention.

[0030] FIG. 6 is a plan view showing a multi-channel radiometer layout on a single RF board.

[0031] FIG. 7 is an exploded isometric view of a compact multi-channel radiometer module showing a base housing, RF board, controller board and top cover.

[0032] FIG. 8 is an isometric view of the assembled multi-channel radiometer module of the present invention.

[0033] FIG. 9 is a top plan view of the multi-channel millimeter wave radiometer module shown in FIG. 8.

[0034] FIG. 10 is a chart showing Dicke radiometer sensitivity of the type shown in FIG. 2.

[0035] FIG. 11 is a chart showing the radiometer sensitivity of the present invention.

[0036] FIG. 12 is a block diagram illustrating basic functional components of the radiometer system of the present invention and showing a hybrid low noise amplifier followed by the switch.

[0037] FIG. 13 is a chart showing a Dicke radiometer system and noise performance of the different components.

[0038] FIG. 14 is a chart showing radiometer system noise performance of a hybrid radiometer system.

[0039] FIG. 15 is a chart showing the radiometer system noise performance for a hybrid/switch radiometer of the present invention.

[0040] FIG. 16 is a block diagram of a hybrid/switch low noise amplifier radiometer of the present invention showing its use of MMIC chips.

Detailed Description of the Preferred Embodiments

[0041] The present invention will now be described more fully hereinafter with reference to the accompanying drawings, in which preferred embodiments of the invention are shown. This invention may, however, be embodied in many different forms and should not be construed as limited to the embodiments set forth herein. Rather, these embodiments are provided so that this disclosure will be thorough and complete, and will fully convey the scope of the invention to those skilled in the art. Like numbers refer to like elements throughout, and prime notation is used to indicate similar elements in alternative embodiments.

[0042] The present invention overcomes many existing shortcomings of current radiometers, including gain variation of the amplifiers, low frequency noise, detector bias, low sensitivity and high cost. The present invention reduces cost and size of a radiometer by a least a factor of ten and provides a commercial advantage over many current radiometers.

[0043] The low cost MMW radiometer of the present invention includes a housing section, a multi-channel RF board, and a controller board. The housing section is preferably made up of a base metal housing and a metallized plastic or metal cover that includes the RF

launch opening, typically filled with a dielectric material, for example, a plastic material to allow for less than one wavelength spacing between the sensing radiators. The RF board preferably is formed from a single soft board or ceramic material. All MMW microstrip circuits, for example, 50 Ohm lines, filters, 90° hybrids and RF radiators, are printed on this board. MMIC amplifiers can be either attached directly to the board or, through cut-outs, on a carrier plate underneath to the RF board. A simple MMIC chip can also be used. A controller board, which uses a low cost microcontroller, performs any necessary video signal amplification, digitization and conditioning, automatic RF amplifier bias adjustment, and DC power regulation. The controller board interfaces with an external display system.

[0044] The compact radiometer of the present invention can fit directly in the antenna focal plane. A quadrature hybrid network is used in the front end to distribute RF input signals and reference signals to a balanced amplifier chain, thereby reducing gain variations and improving radiometer sensitivity. A balanced detector diode circuit, for example, a pair of diodes in one non-limiting example, eliminates drift errors introduced by a detector diode as a function of temperature.

[0045] A video signal chopper amplifier circuit, also referred to by some as a auto zero amplifier, eliminates bias introduced by the video amplifier. A near perfect channel-to-channel matching exists through the use of quadrature hybrid network or through digital signal processing corrections.

[0046] FIG. 1 shows a typical radiometer antenna system **20**. The main antenna **22** collects temperature

data or other pertinent data to be analyzed. The data is focused in the middle of the antenna at the focal plane array **24** using a sub-reflector **26**.

[0047] FIG. 2 shows a common prior art "Dicke" type radiometer system **30**, including a receiver front end. In a Dicke radiometer, generally a receiving circuit detects weak signals in noise and modulates these signals at an input. The circuit demodulates the signals and compares the output with a reference from the modulator. Coincidence indicates a signal presence. For example, microwave noise power can be measured by comparing it with the noise from a standard source in a waveguide.

[0048] In this illustrated example of a Dicke radiometer, the antenna **32** senses target temperature, which is proportional to the radiated target energy. The energy passes through a Dicke switch **34** of the type known to those skilled in the art and into a series of MMIC amplifiers **36a, 36b, 36c**. A band pass filter **38** sets the receiver bandwidth. A square law detector **40** detects the signal and passes it to an integrator **42**, which sums the signal over an observation period. A data acquisition and processing circuit **44** receives the integrated signal, where it is digitized, compensated for gain variation, and processed for display on a video or for further processing. To cancel the effects of gain variation, the Dicke switch **34** samples a reference source **46**. Gain variations in the receiver are cancelled using the measured reference gain.

[0049] Radiometer sensitivity is important. The precision in estimating the measured temperature is often referred to as the radiometer sensitivity, ΔT . This parameter is a key quantity characterizing the performance of a MMW radiometer. In radiometer

terminology, this is the smallest change in temperature that can be detected by the radiometer. The equation, which derives the sensitivity of the system 30 shown in FIG. 2 is:

$$P_{\text{sys}} = P_A + P_{\text{rec}}$$

where P_{sys} = total input power

P_A = Noise power at the antenna = $k T_A B$

P_{rec} = Noise power generated in the receiver = $k T_{\text{rec}} B$

K = Boltzmann's constant

B = receiver bandwidth

[0050] Assuming a square law detector, the radiometer output voltage is an average value of the radiometer output noise power. The square law detector can have an output proportional to the square of the applied voltage, e.g., the output is proportional to the square of the input amplitude. A radiometer output voltage is:

$$V_{\text{out}} = P_{\text{sys}} \times G_{\text{sys}}$$

where G_{sys} is the receiver gain.

[0051] Assuming that G_{sys} and T_{rec} are constant, the radiometer sensitivity is:

$$\Delta T_{\text{ideal}} = (1/\sqrt{B\tau}) T_{\text{sys}}$$

where τ is the integration time.

[0052] In most applications, however, G_{sys} and T_{rec} are not constant, and their variations cause degradation of the radiometer sensitivity as follows:

Gain variations effects:

$$\Delta T_G = (T_A - T_{ref}) \times (\Delta G_{sys}/G_{sys})$$

[0053] Assuming a five degree difference between the antenna temperature and the reference temperature, a +/-3 dB gain variation (over the 3 LNA's **36a**, **36b**, **36c**), and a 40 dB total system gain, the radiometer sensitivity will vary by about 5%.

Temperature variation effects can be shown:

$$\Delta T_{ant} = (T_A + T_{rec}) / (\sqrt{B\tau}/2) = \sqrt{2} (T_A + T_{rec}) / (\sqrt{B\tau})$$

$$\Delta T_{ref} = (T_{ref} + T_{rec}) / (\sqrt{B\tau}/2) = \sqrt{2} (T_{ref} + T_{rec}) / (\sqrt{B\tau})$$

Assuming statistical independence, the temperature variation can be shown:

$$\begin{aligned} \Delta T &= [(\Delta T_G)^2 + (\Delta T_{ant})^2 + (\Delta T_{ref})^2]^{1/2} \\ &= [\frac{2(T_A + T_{rec})^2 + 2(T_{ref} + T_{rec})^2 + (\Delta G_{sys}/G_{sys})^2 (T_A - T_{ref})^2}{(B\tau)^{1/2}}]^{1/2} \end{aligned}$$

Assuming a balanced Dicke radiometer (i.e. $T_A = T_{ref}$), the above equation can be simplified to:

$$\begin{aligned} \Delta T &= 2 (T_A + T_{rec}) / \sqrt{B\tau} \\ &= 2 \Delta T_{ideal} \end{aligned}$$

[0054] Therefore, the Dicke radiometer sensitivity is twice that of an ideal total power radiometer. The factor of two (2) comes about because the Dicke switch alternates between the reference and the antenna such that T_A is observed for only half of the time.

[0055] FIG. 2A shows how the radiometer channels **48**, indicated as channels 1 . . . N, as part of RF modules, are typically connected to the antenna **48a**. Because of the large size of the radiometer RF modules, which cannot fit directly in the antenna focal plane, a waveguide manifold **48b** is used to connect the modules to the focal plane. The waveguide manifold **48b** increases the front end losses by at least 2 dB, resulting in reduced radiometer sensitivity. The channels **48** connect to data acquisition and processing circuit **48c**.

[0056] FIG. 3 is a block diagram of the radiometer **50** of the present invention. This radiometer design does not use a Dicke switch, yet it still delivers superior sensitivity and can be readily manufactured.

[0057] A radiator **52** provides a first signal input A while a reference **54** provides a second signal input B. The radiator **52** could be many types of radiator elements used in radiometers, including an antenna. Microstrip quadrature hybrid circuits **56** are operable with low noise amplifier circuits **58**. The hybrid circuits can be 90° hybrids. Bandpass filter circuits **60a**, **60b** receive the signals represented at A and B, which are output to detector circuits **62a**, **62b**. These components are typically mounted on an RF board indicated by the dashed lines at **64**. The RF board is typically formed from a single soft board or ceramic material. All MMW microstrip circuits, for example, 50 ohm lines, filters, hybrids and RF radiators, are printed on this board. Any MMIC amplifiers can be attached directly to the board, or through cut-outs, on a carrier plate underneath to the RF board.

[0058] The signals (A and B) are output to a controller board indicated by dashed lines at **70**. On

this board, any necessary video signal amplification, digitization and conditioning, automatic RF amplifier bias adjustment, and DC power regulation occurs. This board can interface directly with a video display system. The signal is received at two chopper amplifier circuits **72a**, **72b**. After amplification, the signals are integrated at integrator circuits **74a**, **74b**, and digitized at analog/digital (A/D) circuits **76a**, **76b**. A microcontroller circuit **78** provides digital video processing and receives an antenna temperature signal **80**, amplifier control signal **82**, and reference temperature signal **84**. The output from the microcontroller circuit **78** is sent to a display or other external sensors **86**.

[0059] The radiometer **50** of the present invention uses microstrip quadrature hybrids **56** to distribute the signal and reference powers to the balanced amplifier chain as illustrated. The pairs of low noise amplifiers (LNA's) **58** are cross-coupled to each other, similar to a conventional balanced amplifier configuration.

[0060] The quadrature hybrid shown in FIG. 3A is a well known four-port device that splits the energy into equal parts at the output, but with a 90 degree phase difference. For example, the signal A at the input port P1 of the hybrid is divided up to two parts at the output ports P3 and P4. The same is true for the input signal B at the input port P2 of the hybrid, which is also divided equally at the output ports P3 and P4. When the output of the first hybrid is used as input into a second hybrid, the signals A and B are restored at the output of the second hybrid (of course with some losses due to the hybrids). The two inputs A and B, which can represent the antenna port and the reference

port, or represent two antenna ports representing two different polarizations, are divided equally among the amplifiers and reconstructed at the output, as shown in FIG. 3A. One other unique feature of this hybrid design is that failure of one or more of the LNA's **58** in the chain does not result in failure of the channel itself. Because of the distributed gain approach, the gain of the channel will drop by a small amount, which can be accounted for in the microcontroller **78**. This is different from the traditional radiometer shown in FIG. 2, where failure of one LNA will result in total failure of the element.

[0061] Because each signal passes through each amplifier in the chain, any fluctuation in the gain of any of the amplifiers is applied equally to both signals (T_A & T_{Ref}). Assuming that the hybrid circuits **56** are well balanced by using good design practices, this radiometer design guarantees that the gain in each channel is substantially the same. In addition, because the gain in each channel is essentially the average of that of all the amplifiers in the chain, the overall gain fluctuation is effectively reduced by a factor of the square root of N , where N is the number of amplifiers.

$$\Delta G_{\text{sys}} = \left[\frac{1}{N} \sum_{i=1}^N (\Delta G_i)^2 \right]^{1/2}$$

[0062] Assuming the same amount of the LNA's gain variation (± 3 dB) used for the Dicke radiometer as shown in FIG. 2, the radiometer system gain variation of the present invention will be only about ± 0.7 dB. Therefore, it is evident that the radiometer of the present invention provides the inherent benefits of receiver gain fluctuation reduction and guarantees

equal gain for both the antenna power and the reference signal. This feature provides the same benefit as the Dicke switch without the added losses and the complex switching circuitry. Also, the absence the Dicke switch in the present invention allows continuous observation of the antenna temperature, thereby achieving the sensitivity of a total power radiometer.

$$\Delta T_{\text{ideal}} = (1/\sqrt{B\tau}) T_{\text{sys}}$$

[0063] Using commercially available W-band LNA's with over 20 GHz bandwidth, such as an ALH394 circuit made by Velocium of Redondo Beach, California, and assuming an integration time of 20 msec and 1200 K total system temperature, this radiometer sensitivity is less than 0.1 degree. The ALH394 is a broadband, three-stage, low noise monolithic HEMT amplifier. It has a small die size and is passivated. Bond pad and backside metallization can be Ti/Au and compatible with conventional die attach, thermocompression and thermosonic wire bonding assembly. It can have a usable radio frequency of 76 to about 96 GHz, linear gain of about 17 dB, and a noise figure of about 5 dB depending on applications. It can use DC power of about 2 volts at 34 mA. Bond pads can include VG1, VG2 and VG3, VD1, VD2, VD3, with an RF in and RF out pad.

[0064] The RF signals at the output of the band pass filter **60a**, **60b** are detected using the square law detector **62a**, **62b**. In order to eliminate any detector variation over temperature, a pair of balanced diodes **62a**, **62b**, such as a DBES105a diode manufactured by United Monolithic Semiconductors, can be used. This dual Schottky diode is based on a low cost 1 μm stepper process with bump technology and reduced parasitic

conductances and having a high operating frequency. It can be a flip-chip dual diode with high cut-off frequencies of about 3 THz and a breakdown voltage of less than -5 volts at 20 uA. It has a substantially adequate ideality factor of about 1.2.

[0065] The diodes output an equal amount of power, but with opposite polarity. This method effectively cancels any bias or drift caused by the diodes. The very small DC voltages at the output of the diodes are typically very difficult to amplify accurately. DC offsets introduced by the op-amps are usually a cause of the problem, aggravated often by low frequency noise (1/f). The radiometer **50** of the present invention uses chopping op-amp circuits **72a, 72b**, also known as auto zero amplifiers, such as the AD8628 amplifier manufactured by Analog Devices. This amplifier circuit eliminates DC offset and low frequency (1/f) noise.

[0066] The AD8628 amplifier has ultra-low offset, drift and bias current. It is a wide bandwidth auto-zero amplifier featuring rail-to-rail input and output swings and low noise. Operation is specified from 2.7 to 5 volts single supply (1.35V to 2.5V dual supply). It has low cost with high accuracy and low noise and external capacitors are not required. It reduces the digital switching noise found in most chopper stabilized amplifiers, and has an offset voltage of 1 μ V, a drift less than 0.005 μ V/ $^{\circ}$ C, and noise of 0.5 μ V P-P (0 Hz to 10 Hz). This amplifier is available in a tiny SOT23 and 8-pin narrow SOIC plastic packages.

[0067] An offset voltage of less than 1 μ V allows this amplifier to be configured for high gains without risk of excessive output voltage errors. The small temperature drift of 2 nV/ $^{\circ}$ C ensures a minimum of offset voltage error over its entire temperature range

of -40°C to $+125^{\circ}\text{C}$. It has high precision through auto-zeroing and chopping. This amplifier uses both auto-zeroing and chopping in a ping-pong arrangement to obtain lower low frequency noise and lower energy at the chopping and auto-zeroing frequencies. This maximizes the signal-to-noise ratio (SNR) without additional filtering. The clock frequency of 15 kHz simplifies filter requirements for a wide, useful, noise-free bandwidth. The amplifier is preferably packaged in a 5-lead TSOT-23 package.

[0068] $1/f$ noise, also known as pink noise, is a major contributor of errors in decoupled measurements. This $1/f$ noise error term can be in the range of several μV or more, and when amplified with the closed-loop gain of the circuit, can show up as a large output offset. $1/f$ noise is eliminated internally. $1/f$ noise appears as a slowly varying offset to inputs. Auto-zeroing corrects any DC or low frequency offset, thus the $1/f$ noise component is essentially removed leaving the amplifier free of $1/f$ noise.

[0069] The output of the integrator circuits **74a**, **74b** for both the antenna signal and the reference signals are digitized using highly linear A/D circuits **76a**, **76b** and are sent to the microcontroller **78**, where the reference signal is subtracted from the antenna signal to obtain the actual target temperature. The microcontroller **78** can monitor the temperature of the antenna through a sensor attached to the antenna. Any differences between the antenna and the reference are accounted for and corrections are applied appropriately in software. The microcontroller **78** also controls the LNA bias and monitors the amount of current drawn by each amplifier and adjusts the amplifier gain.

[0070] FIG. 3B shows a two-stage MMIC chip **112** that can be used in the present invention to replace the discrete implementation of the hybrid and cascade LNA's shown in FIG. 3. This MMIC LNA chip receives a signal from the antenna **114** or reference load **116** that enters through signal inputs A and B into the hybrid circuit **118** and into amplifiers **120a**, **120b** through amplifiers **124a**, **124b**, through hybrid **122** to be output as signals A and B amplified.

[0071] FIG. 3C is a block diagram showing a three-stage MMIC LNA chip implementation **125** with respective amplifier circuits **128a** and **128b**.

[0072] Thus, the balanced channel approach of the present invention can use MMIC chips and the implementation of a radiometer channel can occur either by the use of a single millimeter wave monolithic integrated circuit (MMIC) or through discrete implementation using printed hybrids and multiple MMIC LNA's.

[0073] FIG. 3D is a block diagram of the radiometer **50** of the present invention. This radiometer design uses the MMIC chip **112** shown in FIG. 3B to replace the printed hybrids and individual LNA chips. This figure shows yet another example of how this invention can be used to build radiometer channels. Only one detector **62** as a pair of diodes is used. One chopper **72** amplifier and any integrator **74** and A/D circuit **76**.

[0074] The radiometer of the present invention can also be manufactured in an arrangement having a larger number of channels, such as shown in FIG. 4. Prime notation is used to show the various radiators **52'**, hybrid circuits **56'**, and low noise amplifiers **58'**. As illustrated, signals A, B and C are generated from radiators **52'** and a reference signal is generated from

the reference **54'**. Two parallel hybrid circuits **56'** are illustrated at the front end and input into four parallel, low noise amplifier circuits **58'** instead of two as shown in FIG. 3. This follows by other parallel hybrid circuits **56'** and low noise amplifier circuits **58'**. Four bandpass filters **60'** are illustrated with detector circuit **62'** forming a three-element radio frequency module.

[0075] FIG. 5 shows an example of a layout for the RF front end used in the radiometer **50** of the present invention, forming a radiometer cell **90**. The radiator elements **52**, the quadrature hybrids **56**, 50 ohm microstrip lines **59** and the filters **60a**, **60b** are all printed on a soft board or a ceramic board. Isolation vias **100** are used to isolate the amplifiers **58** and reduces the likelihood of oscillations.

[0076] FIG. 6 shows a multi-channel radiometer layout on a single RF board. A plurality of radiometer cells **90** are illustrated, forming a N element array **102** with channels **110**. Radiators **52** are also illustrated. This design approach allows for low cost implementation of a large number of channels. The radiator elements **52** can be spaced half a wavelength ($\lambda/2$) apart for lower cross coupling, lower sidelobes and overall improved operations. The channels **110** are stacked on both sides of the board in order to achieve two rows **110a**, **110b** of radiometer cells **90** in a very small amount of space. For dual polarization applications, one row **110a** may be vertically polarized while the second row **110b** could be horizontally polarized. The radiators, for example as antenna elements, can be alternated between vertical and horizontal polarization in the same row. For example, a 32x2 array can easily

fit a 3x4 inch RF board. This board can become part of a radiometer module of the present invention.

[0077] FIG. 7 shows an exploded view of a compact, multi-channel radiometer module **130** of the present invention. A base housing **131**, typically made-up of aluminum, is used to receive the RF board **64**, which can be attached to a CTE matched carrier **132**. The controller board **70**, which supplies all the DC voltages and control signals, makes contact with the RF board **64** through the use of DC contact connectors. The top cover **134**, which can be made from a plastic material, is metallized everywhere except where the radiator areas **136** correspond to the location of the radiators. These unmetallized radiator areas **136** provide a dielectric media for the RF energy to travel through. Thus, RF launch openings are formed. A slot **70a** in the controller board provides access to the antenna elements. The entire unit is assembled using fasteners, such as screws received in fastener apertures **138a**.

[0078] FIG. 8 shows fully assembled multi-channel radiometer module of the present invention forming a radiometer module or "sensor package" as illustrated.

[0079] FIG. 9 is a top plan view of the multi-channel millimeter wave radiometer module shown in FIG. 8 and showing the radiator areas **136** and radiators. FIGS. 10 and 11 show various components of a Dicke radiometer (FIG. 10) and showing the Dicke radiometer sensitivity as compared to the radiometer sensitivity of the present invention as shown in FIG. 11. The different components of the radiometers and the relative sensitivity and operating or reference values are shown under the specific elements as illustrated.

[0080] The radiometer module of the present invention has at least six times higher sensitivity than more current radiometer sensitivity, such as the Dicke radiometer sensitivity explained above with reference to FIG. 2 and shown in FIG. 10. The present invention is advantageous and provides a radiometer with the sensitivity of less than 1°K. The radiometer module (sensor) is at least ten times smaller than other radiometers currently in use. The radiometer of the present invention also is at least ten times lighter in weight than any other radiometer in existence, which typically weighs no less than 20 pounds. The radiometer of the present invention is typically less than about three pounds.

[0081] The present invention also is self-correcting for temperature and gain variations. It uses the balanced pair of diodes for detection and the chopper operational amplifiers to eliminate any bias and reduce 1/F noise. The microcontroller can monitor temperature changes between the antenna and the reference by reading any temperature sensors located on the antenna and near the reference. This can be based on temperatures to adjust the correction factor. The gain can be continuously monitored and the bias adjusted of the low noise amplifier (LNA) to maintain the constant gain. Real-time corrections can be performed on all video channels to account for any changes in temperature or gain.

[0082] The radiometer of the present invention also has self-healing capability because of the distributed gain approach. Failure of one or more LNA's in each channel will not result in failure of the channel. The microcontroller can compensate for the drop of any amplifiers in the chain.

[0083] FIG. 12 is a block diagram of a radiometer system **200** of the present invention using a combination of hybrid low noise amplifiers and a switch to achieve low system temperature and low implementation cost. Unlike a typical Dicke radiometer where the switch losses translate directly into an increase in system noise figures, and system temperature. Moving the switch after a first low noise amplifier circuit as illustrated in FIG. 12 nearly eliminates the impact of the switch losses. The radiometer system of the present invention combines the benefit of the low noise figure achieved by the hybrid approach and a simple, single channel processing achieved by the Dicke approach.

[0084] FIG. 12 shows an antenna feed **202** operatively connected to the low noise amplifier circuit **204**, which receives antenna signal and the reference signal from the reference load **206**. The low noise amplifier circuit **204** is cross-coupled and quadrature and has signal outputs received at the switch **208** that also receives a signal from a switch control **210**. This circuit could be a microcontroller or other processor as part of or controlled from the controller board. The switch **208** is operatively connected to an adjustable low noise amplifier **212**, which receives a gain control signal from gain control circuit **214**. The output signal enters a band pass filter **216**, low noise amplifier circuit **218** and detector circuit **220**, all of the type that could be used as described for the embodiment shown in FIG. 3 or other embodiments as non-limiting examples. The components as described are contained on an RF board **222** shown by the dashed line.

[0085] The detected signal from the detector circuit **220** passes into an integrator circuit **224** that is

positioned on the controller board **226** and into a sample and hold circuit **228**. The analog signal is then converted into a digital signal by an appropriate analog/digital converter **230** and received in a microcontroller **232** which is operative with a C&M circuit **234**. A power regulation circuit **236** receives DC signals from a DC source **238** and regulates the RF board **222** and controller board **226**. The microcontroller **232** can output a digital signal to a display or other external sensors **240** as described before. It should be understood that the term microcontroller in this description encompasses many different types of controllers and processors.

[0086] FIGS. 13, 14 and 15 show respective comparison of the resulting system noise performance from a traditional Dicke radiometer and the hybrid and the hybrid/switch of the present invention. The left hand side of the chart shows the gain/loss in decibels, followed by the noise figure in decibels, the noise temperature in degrees Kelvin, the cumulative gain, the cumulative NF, and the cumulative temperature. Each of the functional blocks of the radiometer is illustrated with corresponding results listed under that corresponding functional block. For example, FIG. 13 shows the ambient temperature and the various results at the horn, the waveguide transition (WGT), the switch, the two low noise amplifiers, the band pass filter, the low noise amplifier and the detector.

[0087] FIG. 14 shows the results for the hybrid circuit described before, such as with FIG. 3, with the ambient temperature and the horn, the waveguide transition, the low noise amplifier, microstrip, low noise amplifier, band pass filter, low noise amplifier microstrip and detector.

[0088] FIG. 15 shows the results for the hybrid and switch combination of the present invention, showing the ambient temperature, and the functional blocks of the horn, waveguide transition, the low noise amplifier that receives the reference signal, the switch, the microstrip, the low noise amplifier, the band pass filter, the low noise amplifier and detector circuit.

[0089] These results show the system temperature in degrees Kelvin (K) for the three configurations corresponding to the Dicke, hybrid and hybrid/switch. The Dicke radiometer in the example as shown in FIG. 13 results in 2129.9 degrees K system temperature. The hybrid radiometer results in 1337.2 degrees K system temperature. The hybrid/switch radiometer of the present invention results in 1361.2 degrees K. Thus, the hybrid/switch system of the present invention results in only a 24 degree K increase in system temperature over the hybrid approach, but benefits from the single channel process and simplicity of the Dicke radiometer.

[0090] FIG. 16 is another block diagram of the radiometer of the present invention showing how different MMIC chips can be implemented in the combined hybrid/switch radiometer front end of the present invention. As illustrated, signals from the antenna **202** are received in the first MMIC chip **250**, which includes a hybrid **252**, amplifiers **254**, hybrid **256** and non-reflective switch **208**. A second MMIC **260** chip includes amplifiers **262**. This is followed by a filter **264** and a third MMIC chip **266** with appropriate amplifiers **268** and detector **270**. The first MMIC chip **250** combines the hybrid LNA (approximately 20 decibel gain and less than 4 dB NF) configuration with a non-reflective switch **208** of less than about 1.5 dB. The

second LNA chip **260** can be a single channel amplifier of about 16 DB gain which provides the capability of adjusting gain by changing the gate bias (Vg). The third MMIC chip **266** combines a single channel low noise amplifier with a detector diode **270**.

[0091] It is evident that the radiometer of the present invention enhances performance and reduces complexity. The radiometer includes the benefits of the hybrid radiometer performance with the simplicity of single channel processing provided in the Dicke radiometer. A MMIC chip implementation is provided that simplifies the RF front end implementation. One MMIC chip combines the LNA hybrid function with a non-reflective switch and the second LNA is a simple single channel amplifier. The third LNA combines the amplifier function with a zero bias detector diode to provide a low cost, high performance radiometer.

[0092] Many modifications and other embodiments of the invention will come to the mind of one skilled in the art having the benefit of the teachings presented in the foregoing descriptions and the associated drawings. Therefore, it is understood that the invention is not to be limited to the specific embodiments disclosed, and that modifications and embodiments are intended to be included within the scope of the appended claims.

THAT WHICH IS CLAIMED IS:

1. A radiometer system comprising:
 - a hybrid and amplifier circuit that receives an unknown signal and known reference signal;
 - a switch that receives the unknown signal and known reference signal as inputs from the hybrid and amplifier circuit and switches between the signals;
 - a detection circuit that receives and detects a signal from the switch forming a detected signal; and
 - a controller circuit that receives the detected signal and produces a digital output.

2. A radiometer system according to Claim 1, wherein said hybrid and amplifier circuit, switch and detection circuit comprise a radiometer front end.

3. A radiometer system according to Claim 1, wherein said radiometer is sized and of such weight to fit directly into an antenna focal plane.

4. A radiometer system according to Claim 1, wherein said hybrid and amplifier circuit comprises printed hybrids and low noise amplifiers.

5. A radiometer system according to Claim 1, wherein said controller circuit comprises an integrator circuit.

6. A radiometer system according to Claim 1, wherein said controller circuit comprises an analog-to-digital converter for converting the detected signal to digital signals.

7. A radiometer system according to Claim 6, wherein controller circuit comprises a processor that receives the digital signals from the analog-to-digital converter for further processing.

8. A radiometer system according to Claim 1, wherein said hybrid and amplifier circuit and switch comprise a MMIC chip.

9. A radiometer system according to Claim 1, and further comprising an amplifier circuit that receives a signal from the switch before the detection circuit.

10. A radiometer system according to Claim 9, wherein said amplifier circuit comprises a MMIC chip.

11. A radiometer system according to Claim 1, and further comprising two amplifier circuits and filter circuit between the switch and the detection circuit.

12. A radiometer system according to Claim 11, wherein each amplifier circuit comprises a MMIC chip.

13. A radiometer system comprising:
an RF board having a hybrid and amplifier circuit that receives an unknown signal and known reference signal, a switch that receives the unknown signal and known reference signal as inputs from the hybrid and amplifier circuit and switches between the signals, and a detection circuit that receives and detects a signal from the switch forming a detected signal; and

a controller board having a controller circuit that receives the detected signal and produces a digital output.

14. A radiometer system according to Claim 13, wherein said hybrid and amplifier circuit, switch and detection circuit comprise a radiometer front end.

15. A radiometer system according to Claim 13, wherein said radiometer is sized and of such weight to fit directly into an antenna focal plane.

16. A radiometer system according to Claim 13, and further comprising a housing that carries the RF board and controller board.

17. A radiometer system according to Claim 13, wherein said RF board is formed from a soft board or ceramic material.

18. A radiometer system according to Claim 13, wherein said controller circuit comprises an integrator circuit.

19. A radiometer system according to Claim 13, wherein said controller circuit comprises an analog-to-digital converter for converting the detected signal to digital signals.

20. A radiometer system according to Claim 19, wherein controller circuit comprises a processor that receives the digital signals from the analog-to-digital converter for further processing.

21. A radiometer system according to Claim 13, wherein said hybrid and amplifier circuit and switch comprise a MMIC chip.

22. A radiometer system according to Claim 13, and further comprising an amplifier circuit that receives a signal from the switch before the detection circuit.

23. A radiometer system according to Claim 22, wherein said amplifier circuit comprises a MMIC chip.

24. A radiometer system according to Claim 13, and further comprising two amplifier circuits and filter circuit between the switch and the detection circuit.

25. A radiometer system according to Claim 24, wherein each amplifier circuit comprises a MMIC chip.

26. A method of operating a radiometer system which comprises:

receiving an unknown signal and known reference signal within a hybrid and amplifier circuit;

receiving the unknown signal and known reference signal from the hybrid and amplifier circuit and switching between the unknown signal and known reference signal;

detecting the signals after switching; and

receiving the detected signal within a controller circuit and producing a digital signal.

27. A method according to Claim 26, which further comprises forming the hybrid and amplifier circuit as printed hybrids and low noise amplifiers.

28. A method according to Claim 26, which further comprises integrating the detected signal within the controller circuit.

29. A method according to Claim 26, which further comprises converting the detected signal to a digital signal within the controller circuit.

30. A method according to Claim 29, which further comprises processing the digital signal within the controller circuit and producing a digital output.

31. A method according to Claim 26, which further comprises forming the hybrid and amplifier circuit as a MMIC chip.

32. A method according to Claim 26, which further comprises amplifying the signal after switching with an amplifier comprising a MMIC chip.

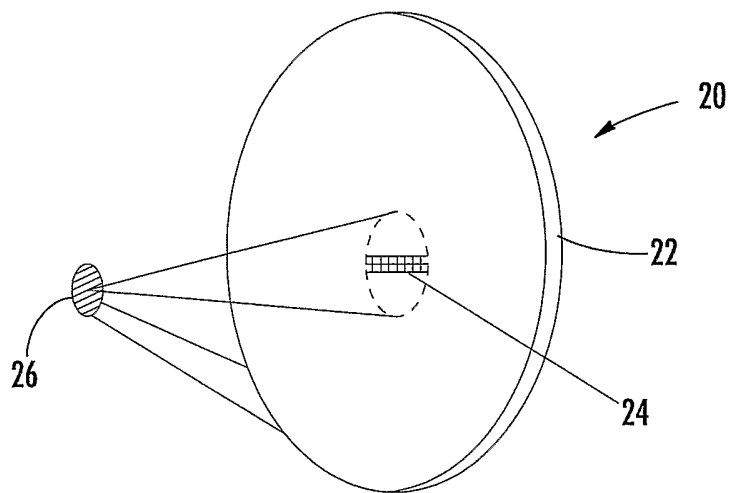

FIG. 1

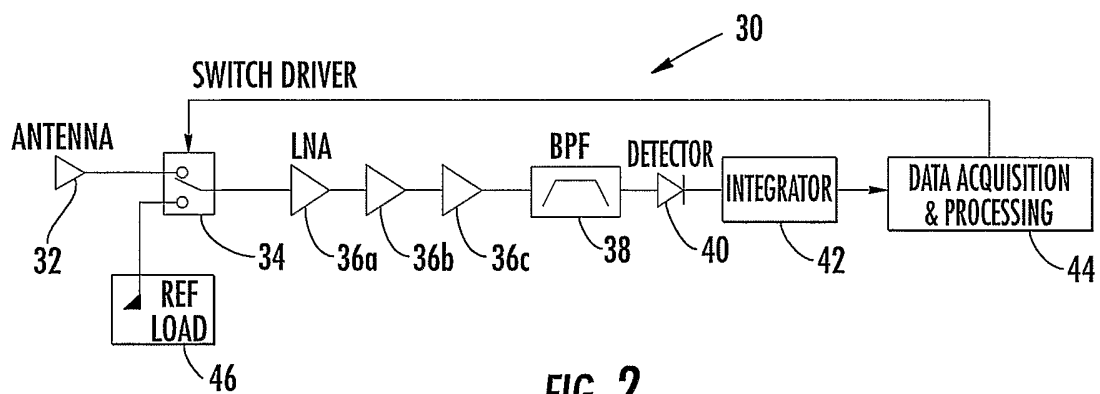

FIG. 2

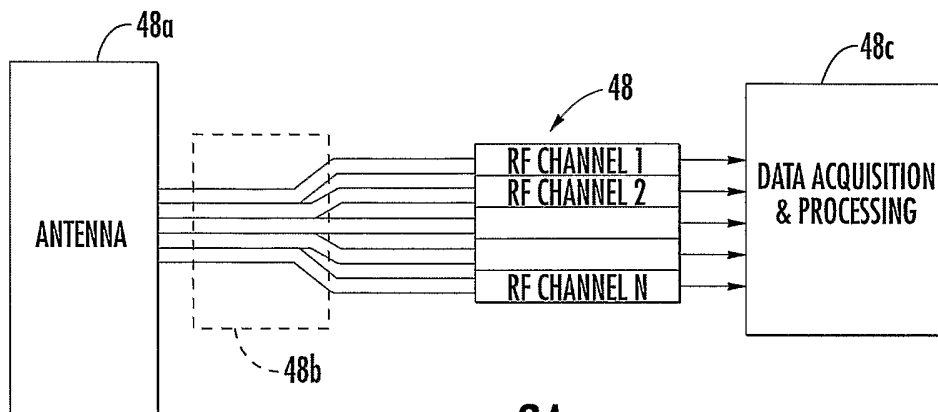

FIG. 2A

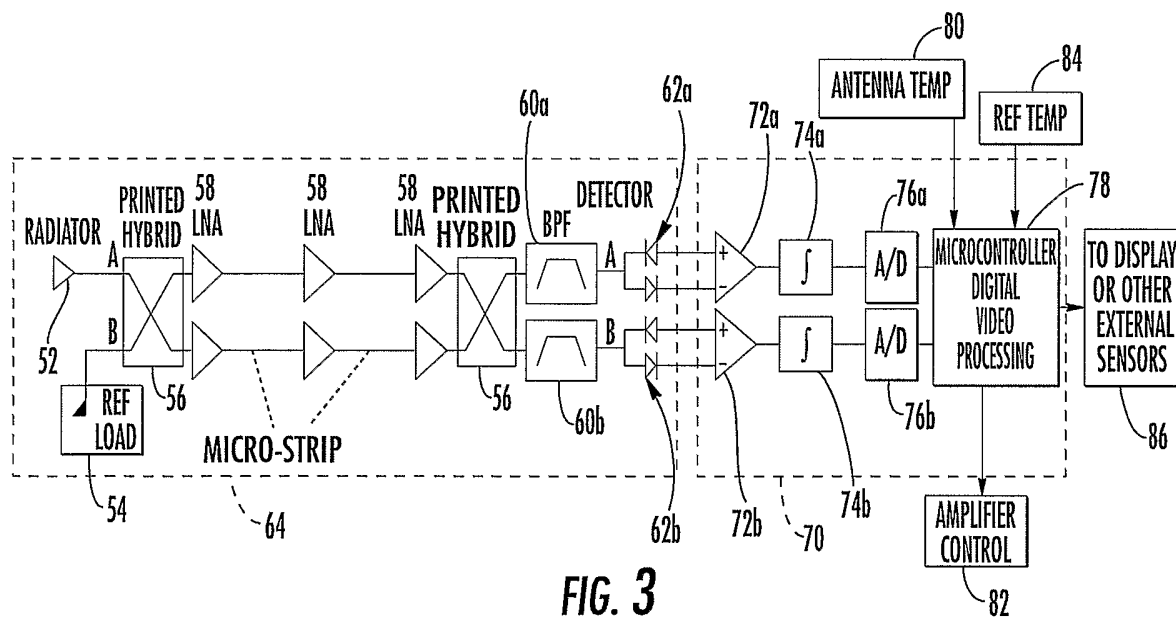

FIG. 3

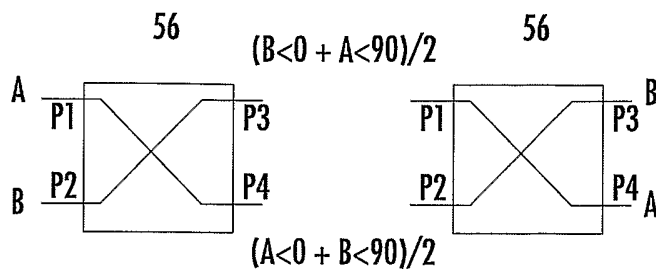

FIG. 3A

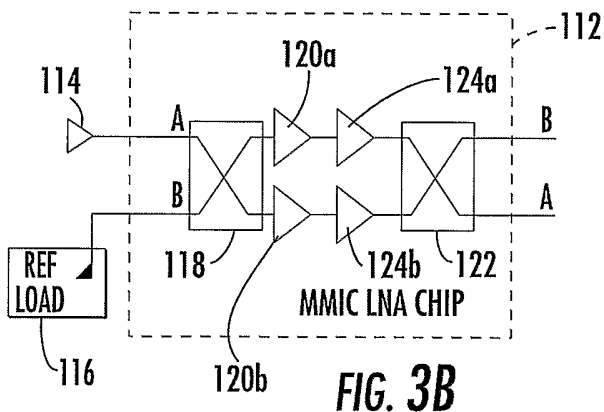

FIG. 3B

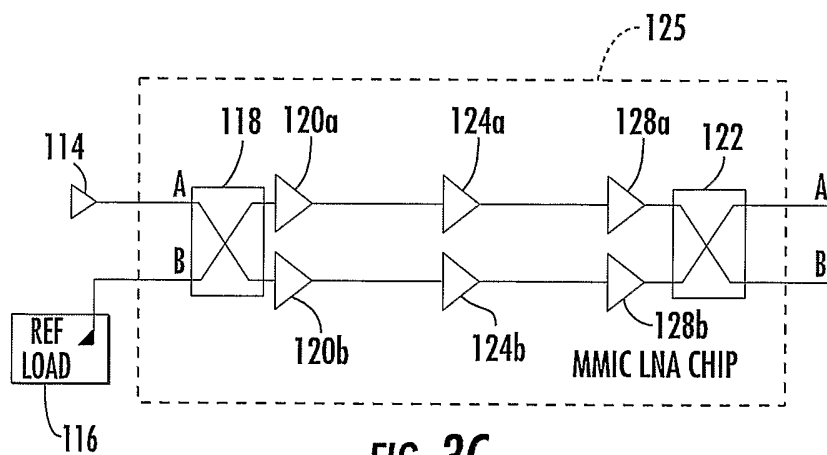

FIG. 3C

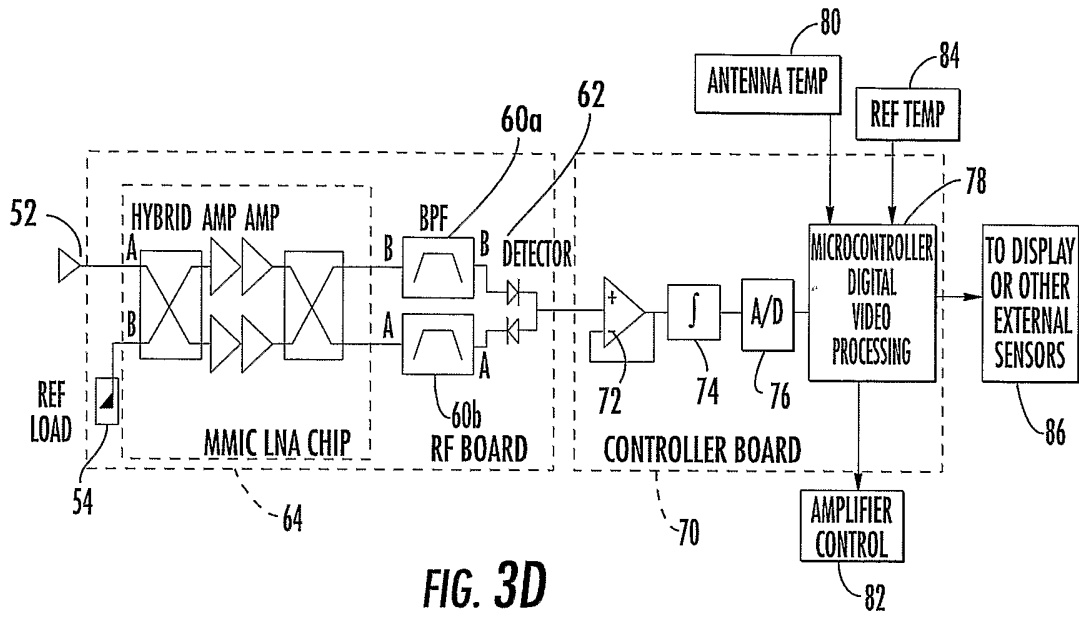

FIG. 3D

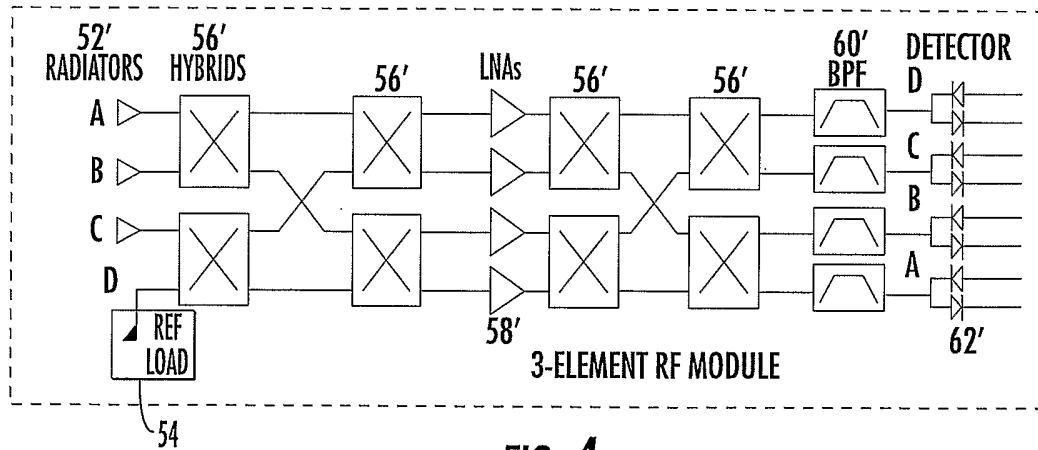
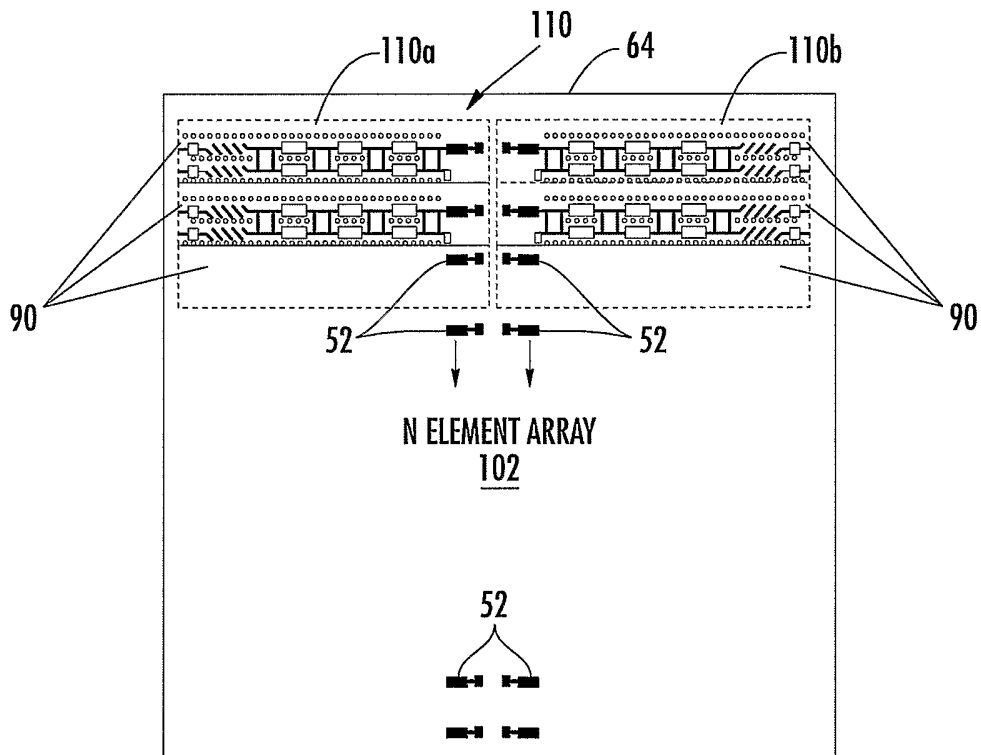
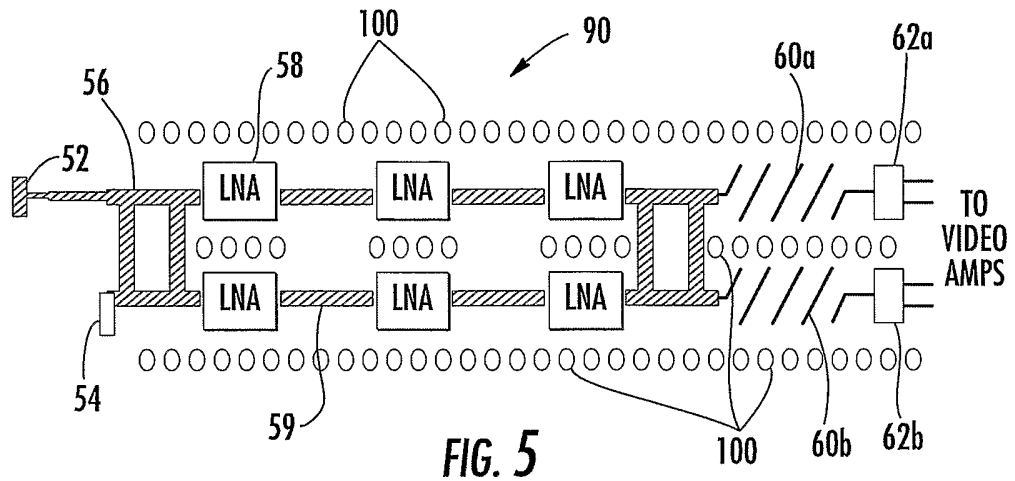

FIG. 4

5/12



6/12

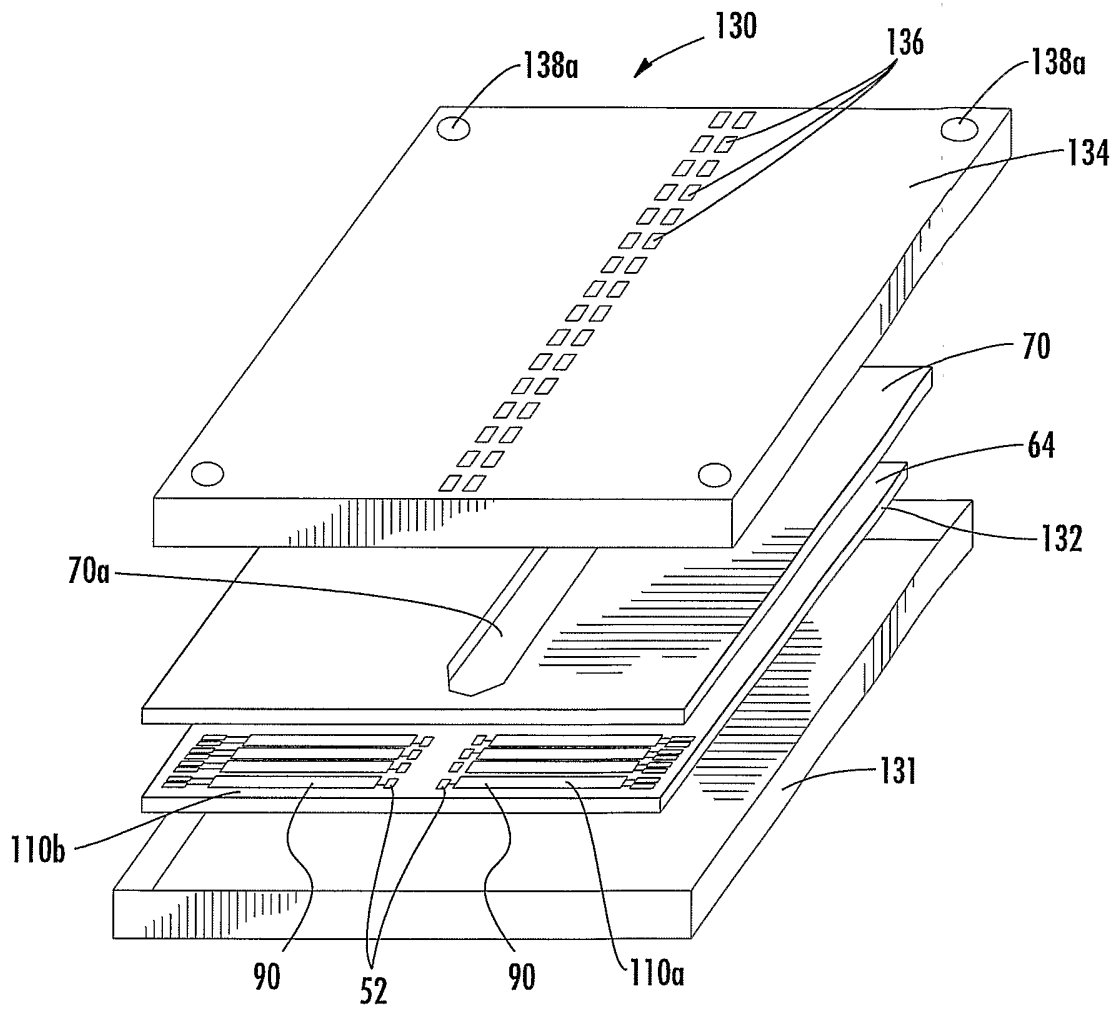

FIG. 7

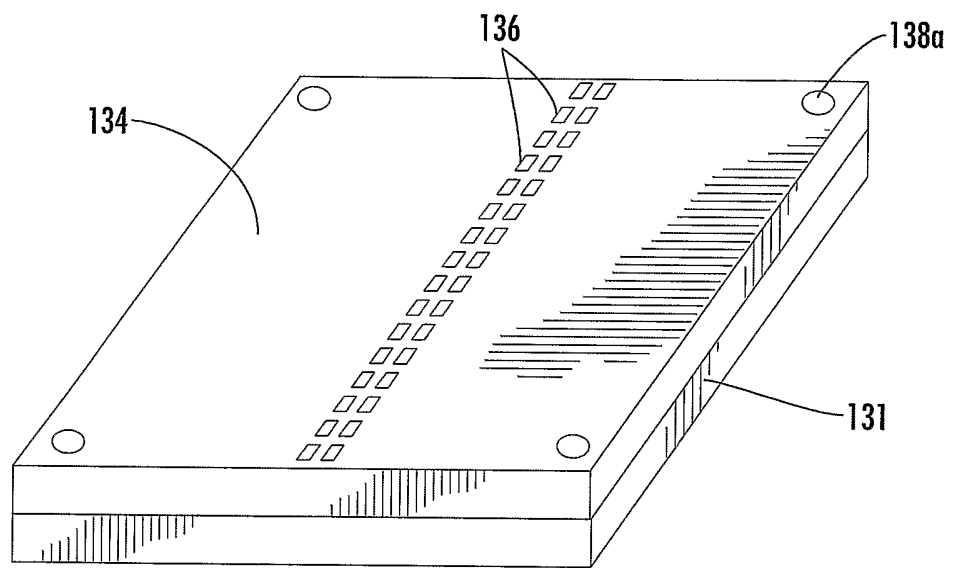

FIG. 8

8/12

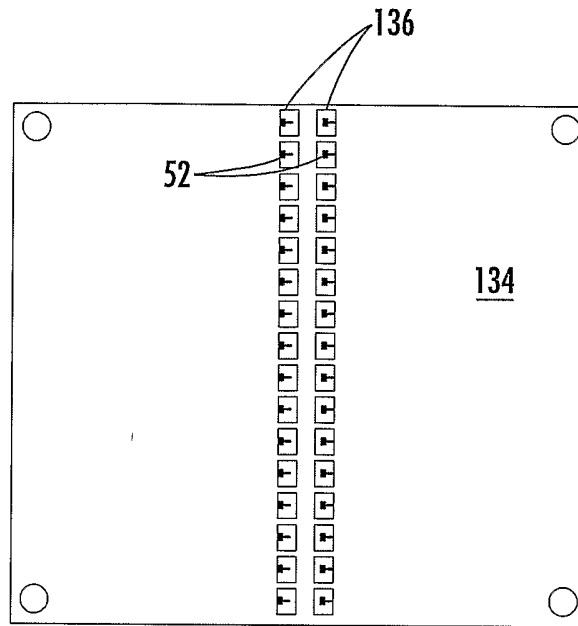

FIG. 9

9/12

NOISE BW (MHZ) = 20000
 TEMP (DEG K) 300
 INTEG. TIME (SEC) 0.010

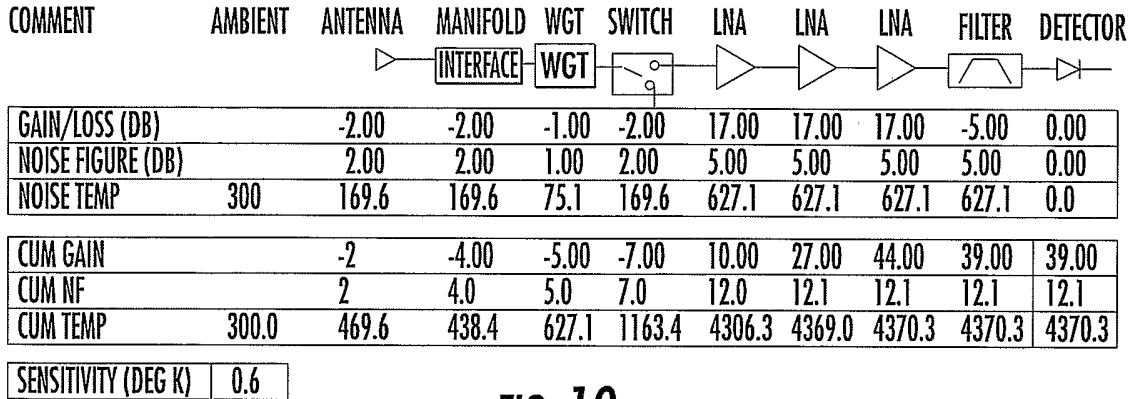

FIG. 10

NOISE BW (MHZ) = 20000
 TEMP (DEG K) 300
 INTEG. TIME (SEC) 0.010

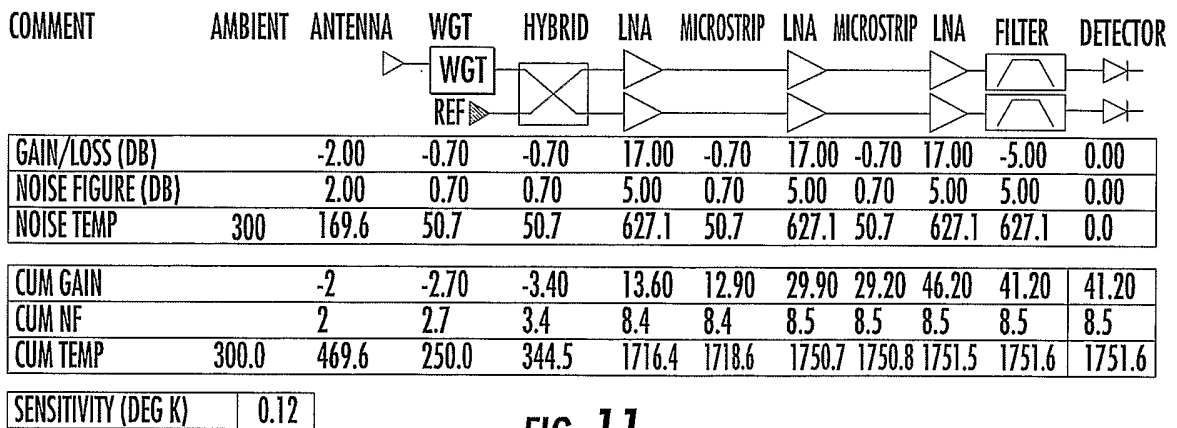

FIG. 11

11/12

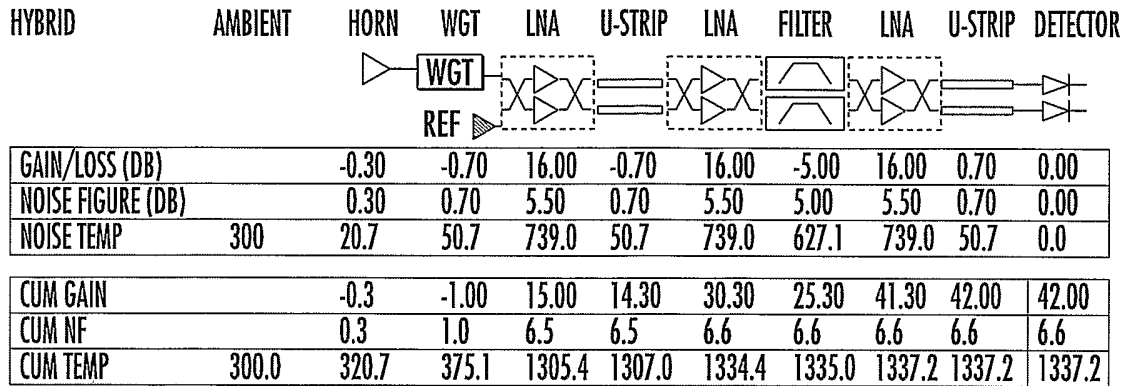

FIG. 14

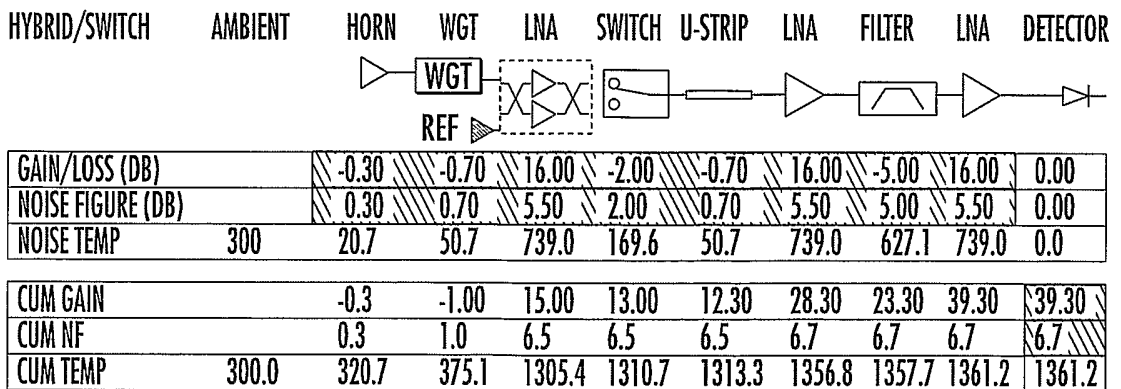

FIG. 15

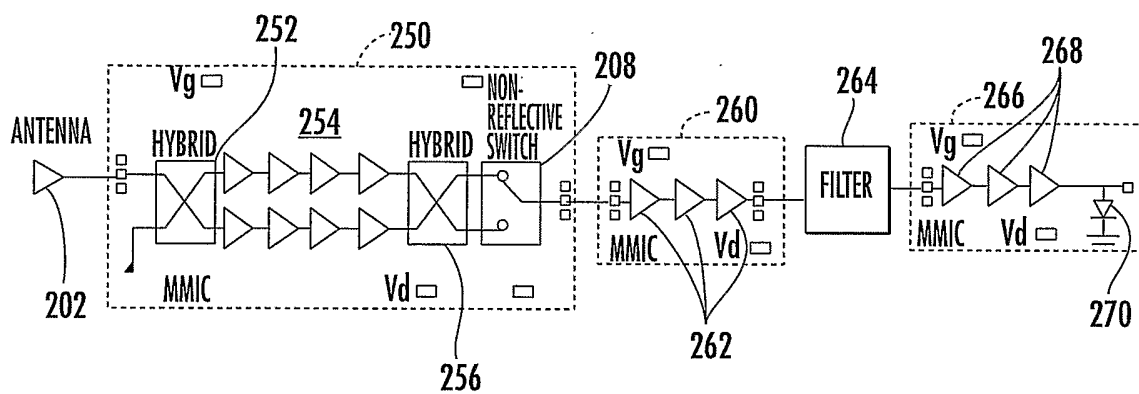

FIG. 16

INTERNATIONAL SEARCH REPORT

International Application No
PCT/US2005/025678

A. CLASSIFICATION OF SUBJECT MATTER IPC 7 G01K11/00		
According to International Patent Classification (IPC) or to both national classification and IPC		
B. FIELDS SEARCHED		
Minimum documentation searched (classification system followed by classification symbols) IPC 7 G01K		
Documentation searched other than minimum documentation to the extent that such documents are included in the fields searched		
Electronic data base consulted during the international search (name of data base and, where practical, search terms used) EPO-Internal, PAJ, INSPEC		
C. DOCUMENTS CONSIDERED TO BE RELEVANT		
Category °	Citation of document, with indication, where appropriate, of the relevant passages	Relevant to claim No.
X	GB 2 211 952 A (* THE SECRETARY OF STATE FOR DEFENCE) 12 July 1989 (1989-07-12)	1, 13, 26
Y	figure 1	4, 5, 8, 10, 12, 17, 18, 23, 25, 31, 32
Y	US 3 777 270 A (HARDY W, CA ET AL) 4 December 1973 (1973-12-04) figure 1	5, 18
Y	US 5 239 685 A (MOE ET AL) 24 August 1993 (1993-08-24) abstract	4, 8, 10, 12, 17, 23, 25, 31, 32
	----- -/--	
<input checked="" type="checkbox"/> Further documents are listed in the continuation of box C. <input checked="" type="checkbox"/> Patent family members are listed in annex.		
° Special categories of cited documents :		
"A" document defining the general state of the art which is not considered to be of particular relevance "E" earlier document but published on or after the international filing date "L" document which may throw doubts on priority claim(s) or which is cited to establish the publication date of another citation or other special reason (as specified) "O" document referring to an oral disclosure, use, exhibition or other means "P" document published prior to the international filing date but later than the priority date claimed		"T" later document published after the international filing date or priority date and not in conflict with the application but cited to understand the principle or theory underlying the invention "X" document of particular relevance; the claimed invention cannot be considered novel or cannot be considered to involve an inventive step when the document is taken alone "Y" document of particular relevance; the claimed invention cannot be considered to involve an inventive step when the document is combined with one or more other such documents, such combination being obvious to a person skilled in the art. "&" document member of the same patent family
Date of the actual completion of the international search 21 October 2005		Date of mailing of the international search report 02/11/2005
Name and mailing address of the ISA European Patent Office, P.B. 5818 Patentlaan 2 NL - 2280 HV Rijswijk Tel. (+31-70) 340-2040, Tx. 31 651 epo nl, Fax: (+31-70) 340-3016		Authorized officer Thomte, M

INTERNATIONAL SEARCH REPORT

International Application No

PCT/US2005/025678

C.(Continuation) DOCUMENTS CONSIDERED TO BE RELEVANT		
Category °	Citation of document, with indication, where appropriate, of the relevant passages	Relevant to claim No.
A	<p>NAKANO H ET AL: "A BROADBAND MICROWAVE RADIOMETER USING CORRELATION TECHNIQUE" IEEE TRANSACTIONS ON INSTRUMENTATION AND MEASUREMENT, IEEE INC. NEW YORK, US, vol. 48, no. 2, April 1999 (1999-04), pages 631-633, XP000930680 ISSN: 0018-9456 the whole document</p> <p>-----</p>	1-32

INTERNATIONAL SEARCH REPORT

Information on patent family members

International Application No

PCT/US2005/025678

Patent document cited in search report		Publication date	Patent family member(s)	Publication date
GB 2211952	A	12-07-1989	NONE	
US 3777270	A	04-12-1973	NONE	
US 5239685	A	24-08-1993	NONE	