

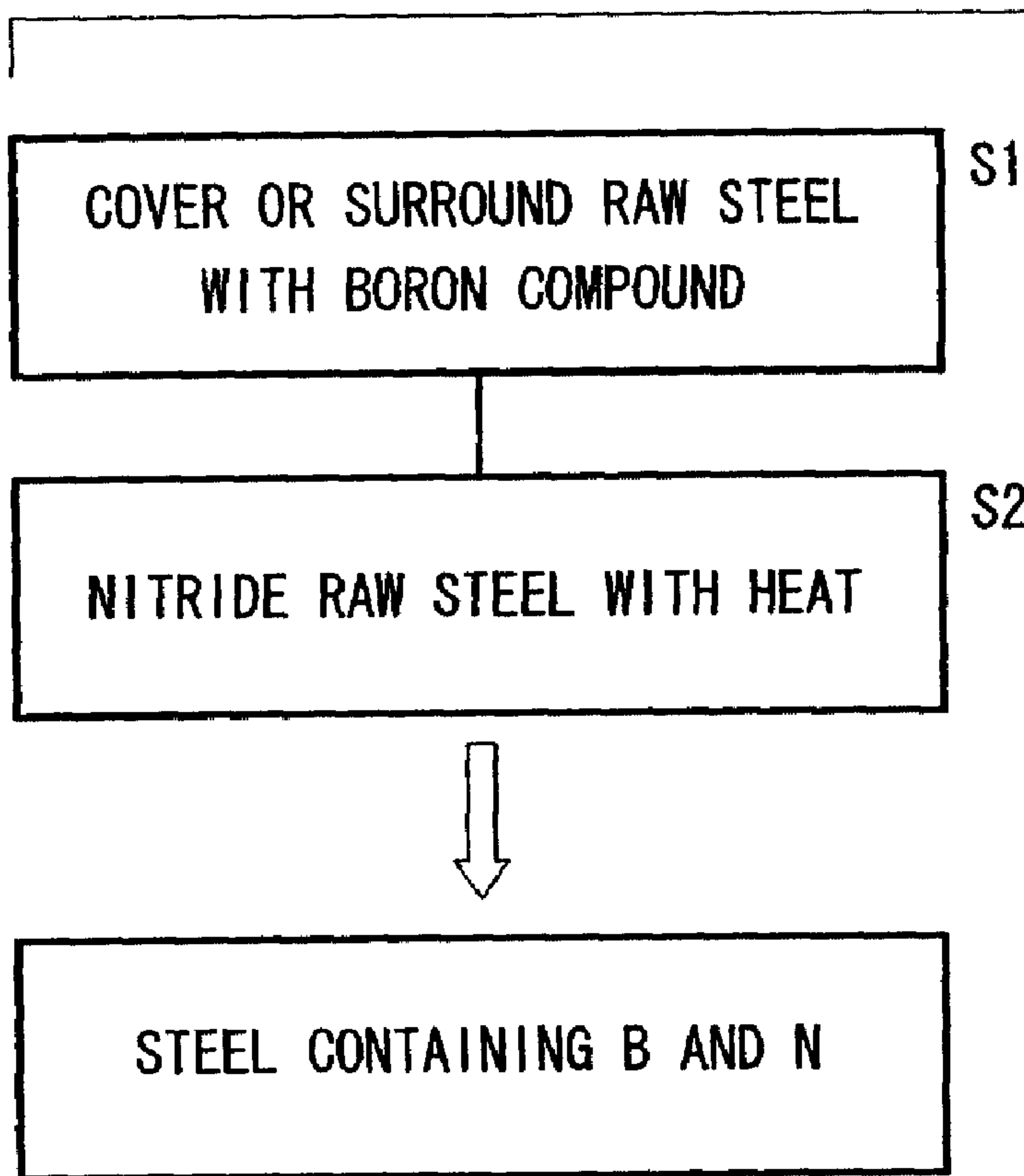

(86) Date de dépôt PCT/PCT Filing Date: 2002/03/20
 (87) Date publication PCT/PCT Publication Date: 2002/09/26
 (45) Date de délivrance/Issue Date: 2009/10/06
 (85) Entrée phase nationale/National Entry: 2003/09/17
 (86) N° demande PCT/PCT Application No.: JP 2002/002653
 (87) N° publication PCT/PCT Publication No.: 2002/075013
 (30) Priorités/Priorities: 2001/03/21 (JP2001-80328);
 2001/03/21 (JP2001-80313)

(51) Cl.Int./Int.Cl. *C23C 8/26* (2006.01),
C23C 8/70 (2006.01)
 (72) Inventeur/Inventor:
 KUWABARA, MITSUO, JP
 (73) Propriétaire/Owner:
 HONDA GIKEN KOGYO KABUSHIKI KAISHA, JP
 (74) Agent: MARKS & CLERK

(54) Titre : MATERIAU EN ACIER ET PROCEDE DE FABRICATION CORRESPONDANT
 (54) Title: STEEL MATERIAL AND METHOD FOR PREPARATION THEREOF



(57) Abrégé/Abstract:

A raw steel is coated with or surrounded by a boron compound (step S1). A coating film of h-BN is formed on the surface of the raw steel. Then, the raw steel is nitrided by a nitriding gas while being heated (step S2). B from the boron compound and N from

(57) **Abrégé(suite)/Abstract(continued):**

the nitriding gas are diffused into the raw steel, turning the raw steel into a steel material containing B and N. Most of B and N are present as an Fe (B, N) solid solution or an Fe (C, B, N) solid solution in the structure of the steel material. The raw steel is heated and nitrided under conditions such that B and N are contained ranging from 7 to 30 ppm by weight and ranging from 10 to 70 ppm by weight, respectively.

ABSTRACT

A raw steel is coated with or surrounded by a boron compound (step S1). A coating film of h-BN is formed on the surface of the raw steel. Then, the raw steel is nitrided by a nitriding gas while being heated (step S2). B from the boron compound and N from the nitriding gas are diffused into the raw steel, turning the raw steel into a steel material containing B and N. Most of B and N are present as an Fe (B, N) solid solution or an Fe (C, B, N) solid solution in the structure of the steel material. The raw steel is heated and nitrided under conditions such that B and N are contained ranging from 7 to 30 ppm by weight and ranging from 10 to 70 ppm by weight, respectively.

DESCRIPTION

STEEL MATERIAL AND METHOD FOR PREPARATION THEREOF

TECHNICAL FILED

5 The present invention relates to a steel material containing B (boron) and N (nitrogen), and a method of manufacturing such a steel material.

BACKGROUND ART

10 Steel material of Fe-C alloy is one of the most general metal materials. Particularly, steel materials containing some elements are referred to as special steel, and widely used as raw materials for structural members, tools, and jigs.

15 Elements contained in the special steels include Al, B, Co, Cr, Mn, Mo, N, Ni, Pb, S, V, Ti, Ta, W, and Zr. These elements improve the characteristics of steel materials by being contained in certain proportions. For example, a boron steel containing B in the range from 40 to 70 ppm by weight (hereinafter, the unit of "ppm" refers to "ppm by weight" unless otherwise specified) exhibits better
20 mechanical strength, hardness, and toughness than general steel materials. A steel containing Pb is known as a free cutting steel that can highly easily be cut off.

25 Those elements in steel materials are present in different states. Almost all elements are present as a solid solution or compound with ferrite (a solid solution

with α -Fe and C) of the steel material, or as a solid solution or compound with cementite (Fe_3C). Some elements may be present as nonmetal compounds such as oxides or sulfides or intermetallic compounds. In the Pb free cutting steel, Pb is present by itself in the steel material without being bonded to other elements.

While a steel material is being rolled, forged or otherwise plastically formed into a desired shape, it is customary to treat the surface thereof by hardening, carburizing, nitriding, etc. In the hardening process, the surface of a steel material is heated to produce an austenite (a solid solution with γ -Fe and C), and then rapidly cooled to produce a martensite. In the carburizing and nitriding processes, after a steel material is heated, C or N is introduced into the steel material from its surface. These surface treatment processes result in a case-hardened steel material.

A boron steel tends to crack while being quenched, and any boron steel workpieces with cracks cannot be used as products. Stated otherwise, when a boron steel is quenched, the yield is lowered. The reason why a boron steel tends to crack is that a trace of Fe, C, Si, Ni, Mo, or the like which is present as a separate impurity in the steel material reacts with B, generating a brittle material such as FeB , Fe_2B , Fe_5SiB_2 , Ni_4B_3 , MoFeB_4 , Mo_2FeB_2 , B_4C , or the like which is precipitated and localized in the crystal grain boundary of the steel material. The brittle material thus

present is liable to suffer large thermal stresses in the steel material when the steel material is quenched.

While a boron steel has good mechanical strength, hardness, and toughness at its surface, these properties are not good enough in the inner structure of the steel because it is difficult to introduce or diffuse boron deeply into the steel material. Boron quickly reacts with the above separate impurity when the steel material is boronized.

When a steel material is carburized or nitrided, C or N is diffused into the steel material usually by a distance of about 0.1 mm or slightly over 0.25 mm at maximum from its surface. Therefore, while the carburizing or nitriding process is effective to harden the surface of the steel material, it fails to harden the inner structure of the steel material beyond the distance of 0.3 mm from the surface. In addition, the toughness of the carburized or nitrided steel material is lower than before it is carburized or nitrided.

Japanese laid-open patent publication No. 53-142933 (published December 13, 1978) proposes another surface treatment process of nitriding a steel material and then boronizing the steel material. According to the proposed surface treatment process, a temperature of heating the steel material in the boronizing process can be lower than a temperature in a boronizing process where the steel material would not be nitrided. Hence, the steel material can be formed into less strained products.

However, as described in the above publication, an Fe-B-N compound is generated only in the surface of the steel material according to the proposed surface treatment process. Since B or N does not enter deeply into the steel material, it is difficult for the process to improve the properties of the steel material in its inner structure.

DISCLOSURE OF THE INVENTION

It is therefore an object of the present invention to provide a steel material having excellent mechanical strength, hardness, and toughness, which is resistant to cracking when heated and can be formed into products at a high yield. It is also an object of the present invention to provide a method of manufacturing such a steel material.

According to the present invention, a steel material contains B ranging from 7 to 30 ppm by weight and N ranging from 10 to 70 ppm by weight.

The steel material which contains B in the above proportion has better mechanical strength, hardness, and toughness than steel materials free of B. N contained in the above proportion in the steel material is effective to suppress reactions between B and separate elements present as impurities in the steel material. Since brittle materials are thus prevented from being formed in the steel material, the steel material is prevented from cracking, and hence can be manufactured at a high yield.

B and N in the steel material may be present as

hexagonal BN (h-BN) or cubic BN (c-BN) or may be combined with Fe and C and present as an Fe-C-B-N boronitride. However, for highest mechanical strength, hardness, and toughness, B and N are preferably present as an Fe (B, N) solid solution with Fe or an Fe (C, B, N) solid solution with Fe and C. Since the structure of the steel material gradually changes, thermal stresses produced in the steel material when heated are small. Therefore, the steel material is further prevented from cracking.

Typical examples of structures in which B and N are present as solid solutions include a ferrite, an austenite, a bainite (a transformed material produced when an austenite is cooled), or the like. A solid solution of Si, Mn, P, S, etc. which are contained in trace quantities in the steel material may be present in the Fe (B, N) solid solution or the Fe (C, B, N) solid solution.

When B and N are introduced as solid solutions in the Fe structure, they can be diffused deeply into the steel material, specifically, by a distance in excess of 0.3 mm. In a conventional case, a distance by which B is diffused in boron steel or by which N is diffused by nitridation is 0.1 mm, and slightly over 0.25 mm at maximum. Thus, B and N can be diffused by a much greater distance.

According to the present invention, there is provided a method of manufacturing a steel material containing B ranging from 7 to 30 ppm by weight and N ranging from 10 to 70 ppm by weight, comprising the steps of covering or

surrounding a raw steel with a boron compound, and nitriding
the raw steel with a nitriding gas while heating the raw
steel in a temperature range from 1100 to 1750 K. The
terminology "raw steel" herein refers to steel before
5 surface treatment.

B and N contained in the steel material are diffused
from the boron compound and the nitriding gas into the steel
material. The steel material containing B in the above
proportion has better mechanical strength, hardness, and
10 toughness than steel materials free of B. N contained in
the above proportion in the steel material is effective to
suppress reactions between B and separate elements present
as impurities in the steel material. Since brittle
materials are thus prevented from being formed in the steel
15 material, the steel material is prevented from cracking.

According to the present invention, it is possible to
manufacture simply and easily a steel material which has
high mechanical strength, hardness, and toughness and is
resistant to cracking.

20 The reason why the raw steel is heated in the
temperature range from 1100 to 1750 K is that if the
temperature were lower than 1100 K, then N would easily be
combined with a ferrite or a cementite and would exceed 70
ppm by weight. If the temperature exceeded 1750 k, then B
25 would quickly be combined with separate elements such as Fe,
Si, Ni, Mo, etc. in the raw steel, generating brittle
borides which would make the steel material susceptible to

cracking.

5 One preferred means for heating the raw steel is a high-frequency heating device because the high-frequency heating device is capable of heating the raw steel to a desired temperature within a short time, the steel material can be manufactured more efficiently.

10 Preferably, the raw steel is placed in a tubular member, and the nitriding gas is passed in the tubular member while the raw steel is being heated by the high-frequency heating device. Inasmuch as the nitriding gas is maintained in reliable contact with the raw steel, the raw steel can be nitrided efficiently with the high-frequency heating device.

15 The boron compound should preferably comprise hexagonal BN (h-BN) or B_4C . These boron compounds are easily available in the market, making it possible to reduce the cost of manufacture of the steel material.

20 The nitriding gas should preferably comprise a gas of N_2 . Since the amount of N to be diffused into the raw steel is very small and the gas of N_2 is inactive, it is easy to control the amount of N diffused into the raw steel.

25 The above and other objects, features, and advantages of the present invention will become more apparent from the following description when taken in conjunction with the accompanying drawings in which preferred embodiments of the present invention are shown by way of illustrative example.

BRIEF DESCRIPTION OF THE DRAWINGS

FIG. 1 is a flowchart of a process of manufacturing a steel material;

5 FIG. 2 is a table showing Vickers hardness of steel materials of the Inventive Examples 1 and 2 from one end to the other thereof;

10 FIG. 3 is a table showing tensile values and Charpy impact values of test pieces obtained from the steel materials of the Inventive Examples 1 and 2 and Comparative Example 1;

FIG. 4 is a graph showing the relationship between distances from the surfaces of steel materials of the Inventive Examples 3 and 4 and Comparative Example 2 and Vickers hardness thereof;

15 FIG. 5 is a table showing the relationship between heat-nitriding times, proportions by weight of boron, Rockwell hardness (C scale) of surfaces, tensile strength values, and fracture toughness values of steel materials;

20 FIG. 6 is a table showing the relationship between heat-nitriding times, proportions by weight of boron, Rockwell hardness (C scale) of surfaces, tensile strength values, and fracture toughness values of steel materials;

FIG. 7 is a perspective view of a raw steel and half pieces of a cylindrical member mounted on the raw steel;

25 FIG. 8 is a perspective view of the cylindrical member mounted on the raw steel shown in FIG. 7; and

FIG. 9 is a graph showing the relationship between

distances from the surfaces of steel materials of the
Inventive Examples 5 through 7 and Comparative Example 3
and Vickers hardness thereof.

5 BEST MODE FOR CARRYING OUT THE INVENTION

A steel material according to the present invention
contains B and N which are present as an Fe (B, N) solid
solution or an Fe (C, B, N) solid solution in a ferrite,
austenite, a bainite, or the like. A solid solution of Si,
10 Mn, P, S, or the like contained in a trace amount in the
steel material may further be present in the above solid
solution.

B is a component for improving the mechanical strength,
hardness, and toughness of the steel material, as with the
15 boron steel. B is contained in a proportion ranging from 7
to 30 ppm. If the proportion of B were smaller than 7 ppm,
then it would not be effective enough to improve the above
properties of the steel material. If the proportion of B
were greater than 30 ppm, then the toughness of the steel
20 material would be lowered. Preferably, B should be
contained in a proportion ranging from 10 to 20 ppm.

N is a component for suppressing reactions between B
and Fe, Si, Ni, Mo, etc. contained as separate impurities in
the steel. N is effective to greatly suppress reactions
25 between B and these separate elements, thus greatly
suppressing the generation of brittle materials such as FeB,
Fe₂B, Fe₅SiB₂, Ni₄B₃, MoFeB₄, Mo₂FeB₂, B₄C. Accordingly, the

steel material according to the present invention suffers much smaller thermal stresses generated when heated in various heat treatment processes such as quenching than general boron steels, and hence is resistant to cracking.

5 N is contained in a proportion ranging from 10 to 70 ppm. If the proportion of N were less than 10 ppm, then it would not be effective enough to prevent the steel material from cracking. If the proportion of N were greater than 70 ppm, then the hardness of the steel material would be
10 lowered.

As described above, B and N are present as an Fe (B, N) solid solution or an Fe (C, B, N) solid solution in the steel material. The steel material exhibits better mechanical strength, hardness, and toughness than steel materials in which B and N are present as h-BN or c-BN.
15

In the steel material according to the present invention, B and N are diffused at a large distance. Specifically, B and N are introduced more deeply into the steel material than into boron steels and nitrided steel materials because B is greatly suppressed against reactions with separate elements in the steel material. Specifically, both B and N are occasionally present within an inner structure of the steel material according to the present invention beyond a distance of 30 to 70 mm from the surface
20 of the steel material.
25

The structure of the steel material gradually varies from the surface to the inside thereof. Therefore, since

thermal stresses produced when the steel material is heated are greatly reduced, the steel material is highly resistant to cracking.

As described above, B and N are diffused deeply within the steel structure according to the present invention. Consequently, the steel structure exhibits excellent mechanical strength, hardness, and toughness also within its inner structure, and hence is highly resistant to cracking.

The steel material according to the present invention is manufactured as follows:

FIG. 1 shows a flowchart of a process of manufacturing the steel material according to the present invention. As shown in FIG. 1, the manufacturing process has a first step S1 of covering or surrounding a raw steel with a boron compound, and a second step S2 of nitriding the raw steel with heat.

In the first step S1, a raw steel is covered with or surrounded by a boron compound. Specifically, if the raw steel is to be covered with a boron compound, then a coating film of a boron compound is formed on the surface of the raw steel. The coating film may be formed easily and simply by spraying a solution of a boron compound such as h-BN or the like dispersed in a solvent such as of xylene, toluene, acetone, or the like, to the surface of the raw steel, and then volatilizing away the solvent. Alternatively, the coating film may be formed by chemical vapor deposition (CVD) or physical vapor deposition (PVD).

If the raw steel is to be surrounded by a boron compound, then a powdery boron compound such as B_4C or the like may be filled in a crucible which contains the raw steel therein.

5 In the second step S2, the raw steel covered with the coating film or surrounded by the powdery boron compound is nitrified with heat. In the nitrifying process, the raw steel is nitrified, and B is diffused from the boron compound from the surface of the steel material into the inside of the steel material. N which is applied to nitride the raw steel is also introduced from the surface of the steel material into the inside of the steel material. As a result, the steel material described above is obtained.

10

A nitrifying gas used to nitride the raw steel may be a mixed gas containing NH_3 , such as a mixed gas of NH_3 , N_2 , and H_2 or a mixed gas of NH_3 , N_2 , and Ar, but should preferably be a gas consisting of N_2 only. The N_2 gas is preferable because the proportion by weight of N to be diffused into the raw steel is very small, i.e., ranges from 10 to 70 ppm, as described above, and the gas of N_2 is inactive enough to easily control the amount of N diffused into the raw steel.

15

20

The nitrifying gas is introduced into the sintering or heating furnace when the temperature is in the range from 1100 to 1750 K. If the temperature were lower than 1100 K, then N would easily be turned into a solid solution in a ferrite, austenite, or bainite, and would have its proportion by weight in excess of 70 ppm. If the

25

temperature were higher than 1750 K, then B would quickly be combined with separate elements such as Fe, Si, Ni, Mo, etc. in the raw steel, generating brittle borides which would make the steel material susceptible to cracking. When the temperature is outside of the above temperature range, an inactive nitriding gas such as Ar or the like may be introduced into the heating furnace. If the coating film is formed on the surfaced of the raw steel, then the heating furnace may be evacuated.

In the step S2, the raw steel may be heated by any heating means. However, a high-frequency induction heating device is particularly preferred because the device can raise the temperature of the raw steel within a short period of time to manufacture the steel material efficiently. If the high-frequency induction heating device is used, then the raw steel is preferably placed in a cylindrical member, and nitrided with a nitriding gas flowing through the cylindrical member. Inasmuch as the nitriding gas is maintained in reliable contact with the raw steel, the raw steel can be nitrided efficiently with the high-frequency induction heating device. The cylindrical member may be made of quartz or graphite.

In the nitriding process, the raw steel is heated for about 10 minutes to 2 hours in the heating furnace or for about 5 seconds to 5 minutes with the high-frequency induction heating device, depending on the thickness and volume of the raw steel. If the nitriding time were too

long, then the proportions of B and N would exceed 30 ppm and 70 ppm, respectively.

Examples:

1. Effects of B and N:

5 A raw steel of S50C according to JIS (Japanese Industrial Standard) in the form of a rectangular parallelepiped having a size of 50 mm × 50 mm × 100 mm was prepared. A solution of h-BN dispersed in xylene was sprayed to the surface of the raw steel. Then, the raw
10 steel was left to stand at room temperature and dried, thus forming a coating film of h-BN on the surface of the raw steel.

 The raw steel was then placed in a heating furnace, and heated to 1600 K at a rate of 10 K/min. Then, the raw steel
15 was kept at 1600 K for 30 minutes. The raw steel was nitrided with heat into a steel material containing B and N. The steel material thus manufactured is referred to as Inventive Example 1. The heating furnace was evacuated until the temperature reached 1200 K, and N₂ was introduced
20 into the heating furnace immediately after the temperature reached 1200 K.

 The proportions by weight of B and N in the steel material of the Inventive Example 1 were determined as 17 ppm and 20 ppm, respectively, as a result of a quantitative
25 analysis by way of absorption spectrophotometry.

 A raw steel of the same size as described above was prepared and pressed into a crucible filled with a powder of

B₄C, so that the raw steel was surrounded by the powder of B₄C.

The raw steel contained in the crucible was placed into a heating furnace, and nitrided with heat under the same conditions as with the Inventive Example 1, producing a steel material. The steel material thus manufactured is referred to as Inventive Example 2. The proportions by weight of B and N of the steel material of the Inventive Example 2 were 18 ppm and 50 ppm, respectively.

A cylindrical raw steel having a diameter of 10 mm and a length of 30 mm were heated with flames and then quenched. The raw steel thus prepared is referred to as Comparative Example 1. B and N were not detected in the raw steel of the Comparative Example 1.

The steel materials of the Inventive Examples 1, 2 and the Comparative Example 1 were measured for Vickers hardness. The Vickers hardness value of the surface of the raw steel of the Comparative Example 1 was 640. As shown in FIG. 2, the Vickers hardness values of the steel materials of the Inventive Examples 1, 2 from one end to the other were about 80 to 100 higher than the raw steel of the Comparative Example 1. This result indicates that the inclusion of B and N increases the hardness of a steel material. Since the hardness of the steel materials of the Inventive Examples 1, 2 is substantially uniform, it can be seen that B and N are diffused from the surface to the inner structure of these steel materials.

Test pieces for a tensile test and test pieces for a impact test were cut from the steel materials of the Inventive Examples 1, 2 and the Comparative Example 1, and measured for Vickers hardness values and Charpy impact values. The results of the test are shown in FIG. 3. Higher Charpy impact values indicate higher toughness values. It can be understood from FIG. 3 that the steel materials of the Inventive Examples 1, 2 have better tensile strength and toughness than the steel material of the Comparative Example 1.

It is apparent from the above results that it is possible to increase the hardness, mechanical strength, and toughness of a steel material by adding B and N to the steel material.

A steel material was produced in the same manner as with the Inventive Example 1 except that SCM 430 (according to JIS) was selected as raw steel. The steel material thus produced is referred to as Inventive Example 3.

Another steel material was produced in the same manner as with the Inventive Example 3 except that while the heating furnace was being evacuated, the raw steel was heated to 1200 K at a rate of 10 K/min, then kept at 1200 K for 30 minutes, heated to 1500 K whereupon a gas of N₂ was introduced, and then kept at 1650 K for 30 minutes. The steel material thus produced is referred to as Inventive Example 4.

A raw steel of SCM 430 having the same size as the

Inventive Examples 3, 4 was dipped for 2 hours in a salt bath of 115 g of KCl, 20 g of BaCl₂, 7.5 g of NaF, 1 g of B₂O₃, and 5 g of ferroboration which were dissolved in 1000 cm³ of water as a solvent. The raw steel thus dipped in the salt bath was boronized, and is referred to as Comparative Example 2.

The proportions by weight of B and N of the steel materials of the Inventive Examples 3, 4 and the Comparative Example 2 were determined as 19 ppm, 21 ppm, and 2 ppm, respectively, as a result of a quantitative analysis.

The steel materials of the Inventive Examples 3, 4 and the Comparative Example 2 were measured for Vickers hardness from their surface to inner structure. The relationships between distances from the surfaces and Vickers hardness values are illustrated in FIG. 4. It is apparent from FIG. 4 that whereas the Vickers hardness of the steel material of the Comparative Example 2 sharply decreases at a depth in excess of 0.05 mm, the Vickers hardness of the steel materials of the Inventive Examples 3, 4 is excellent even at a depth in excess of 0.3 mm. It can be understood from the results shown in FIG. 4 that B was diffused more deeply into the steel materials of the Inventive Examples 3, 4 than the steel material of the Comparative Example 2.

2. The relationships between heat-nitriding times and proportions by weight of boron, Rockwell hardness values (C scale) of surfaces, tensile strength values, and fracture

toughness values of steel materials:

5 Various raw steels of rectangular parallelepiped having the same length and different base areas were prepared from the steel of SKS 93 (according to JIS). Solid solutions of B and N were produced in the forms of rectangular parallelepiped in the same manner as with the Inventive Example 1 except that a gas of N₂ was introduced when the temperature reached 1400 K and the raw steels were kept at the temperature for several periods of time, producing steel materials. Test pieces for a tensile test and test pieces for measuring fracture toughness (K_{IC}) were cut from the steel materials having bottom surface dimensions in excess of 40 mm × 40 mm, and the tensile strength and fracture toughness (K_{IC}) were determined for each of the test pieces. 10 The Rockwell hardness values (C scale, H_{RC}) of the surfaces of the steel materials were also measured. The measured results together with nitriding times (temperature-holding times) in the nitriding process and the proportions by weight of the contained B are shown in FIGS. 5 and 6. 15

20 FIGS. 5 and 6 clearly indicate that the properties of the steel materials can be controlled by setting the processing times.

3. Suppression of cracking:

25 As shown in FIG. 7, a cylindrical raw steel 10 of SCM 420 (according to JIS) having a diameter of 50 mm and a length of 200 mm was prepared. A solution of h-BN dispersed

in xylene was sprayed to the surface of the raw steel, left at room temperature and dried, thus forming a coating film of h-BN (not shown) on the surface of the raw steel. A through hole 12 having a diameter of 8 mm was formed substantially centrally in the raw steel 10, the through hole 12 having an axis perpendicular to the axis of the raw steel 10.

Half pieces 16a, 16b, each semicylindrical in shape, having a plurality of holes 14 defined therein near one end thereof, were mounted on the raw steel 10, thus producing a cylindrical member 18 shown in FIG. 8. A gas of N₂ was passed through the holes 14 in the cylindrical member 18, and the cylindrical member 18 was rotated at a speed of 30 rpm. The raw steel 10 was heated by a high-frequency heating device under the conditions of 480 V, 48 kW, and 19 kHz for 10 seconds, thus producing a steel material. The steel material thus produced is referred to as Inventive Example 5.

Steel materials were prepared in the same manner as with the Inventive Example 5 except that the raw steels were heated for 15 seconds or 30 seconds. The steel materials thus produced are referred to as Inventive Examples 6, 7, respectively. In the Inventive Example 7, the raw steel 10 and the steel material were measured for B, N by a quantitative analysis. B, N were not detected in the raw steel 10, whereas B, N were detected as 17 ppm and 50 ppm, respectively, in the steel material.

For comparison, the raw steel 10 which was free of a coating film was heated and quenched by a high-frequency heating device, producing a steel material. Specifically, the raw steel 10 was heated for 8 seconds under the conditions of 460 V, 45 kW, and 19 kHz while the raw steel 10 was being rotated at a speed of 30 rpm in the atmosphere. The steel material thus produced is referred to as Comparative Example 3.

The steel materials of the Inventive Examples 5 through 7 and the Comparative Example 3 were inspected for cracking. It was confirmed that cracks were formed around the through hole 12 in 6 out of 10 specimens of the Comparative Example 3. No cracks were recognized in all 40 specimens of the Inventive Examples 5 through 7.

The steel materials of the Inventive Examples 5 through 7 and the Comparative Example 3 were measured for Vickers hardness from their surface to inner structure. The relationships between distances from the surfaces and Vickers hardness values are illustrated in FIG. 9.

It is apparent from FIG. 9 that whereas the Vickers hardness of the steel material of the Comparative Example 3 sharply decreases at a depth in excess of 2 mm, the Vickers hardness of the steel materials of the Inventive Examples 5 through 7 is gradually lowered. It can be understood from the results shown in FIG. 9 that the structure of the steel material of the Comparative Example 3 sharply changes, and the structure of the steel materials of the Inventive

Examples 5 through 7 gradually changes. The steel materials of the Inventive Examples 5 through 7 having such structure suffer much smaller thermal stresses produced when heated than the steel material of the Comparative Example 3. It appears that this is the reason why no cracks were formed in the steel materials of the Inventive Examples 5 through 7.

Although certain preferred embodiments of the present invention have been shown and described in detail, it should be understood that various changes and modifications may be made therein without departing from the scope of the appended claims.

The embodiments of the invention in which an exclusive property or privilege is claimed are defined as follows:

1. A steel material containing B ranging from 7 to 30 ppm by weight and N ranging from 10 to 70 ppm by weight, wherein B and N are diffused from a surface into an inner structure of the steel material and contained as an Fe (B, N) solid solution or an Fe (C, B, N) solid solution with Fe which is a constituent element of the steel material, B and N being diffused by a distance in excess of 0.3 mm.

2. A steel material containing B ranging from 7 to 30 ppm by weight and N ranging from 10 to 70 ppm by weight, wherein B and N are diffused from a surface into an inner structure of the steel material and contained as an Fe (B, N) solid solution or an Fe (C, B, N) solid solution with Fe which is a constituent element of the steel material in an austenite structure, B and N being diffused by a distance in excess of 0.3 mm.

3. A method of manufacturing a steel material containing B ranging from 7 to 30 ppm by weight and N ranging from 10 to 70 ppm by weight, wherein B and N are diffused from a surface into an inner structure of the steel material and contained as an Fe (B, N) solid solution or an Fe (C, B, N) solid solution with Fe which is a constituent element of the steel material, B and N being diffused by a distance in excess of 0.3 mm, comprising the steps of:

coating a surface of a raw steel with a boron compound to form a film or surrounding said surface of said raw material by a powdery boron compound; and

nitriding said raw steel with a nitriding gas while heating said raw steel in a temperature range from 1100 to 1750 K.

4. A method according to claim 3, wherein said raw steel is heated by a high-frequency heating device.

5. A method according to claim 4, further comprising the step of placing said raw steel in a tubular member;

wherein in the nitriding step said raw steel is nitrided with the nitriding gas passing in said tubular member while said raw steel is being heated by said high-frequency heating device.

6. A method according to claim 3, 4 or 5, wherein said boron compound comprises hexagonal BN or B₄C.

7. A method according to any one of claims 3 to 6, wherein said nitriding gas comprises a gas of N₂.

1/9

FIG. 1

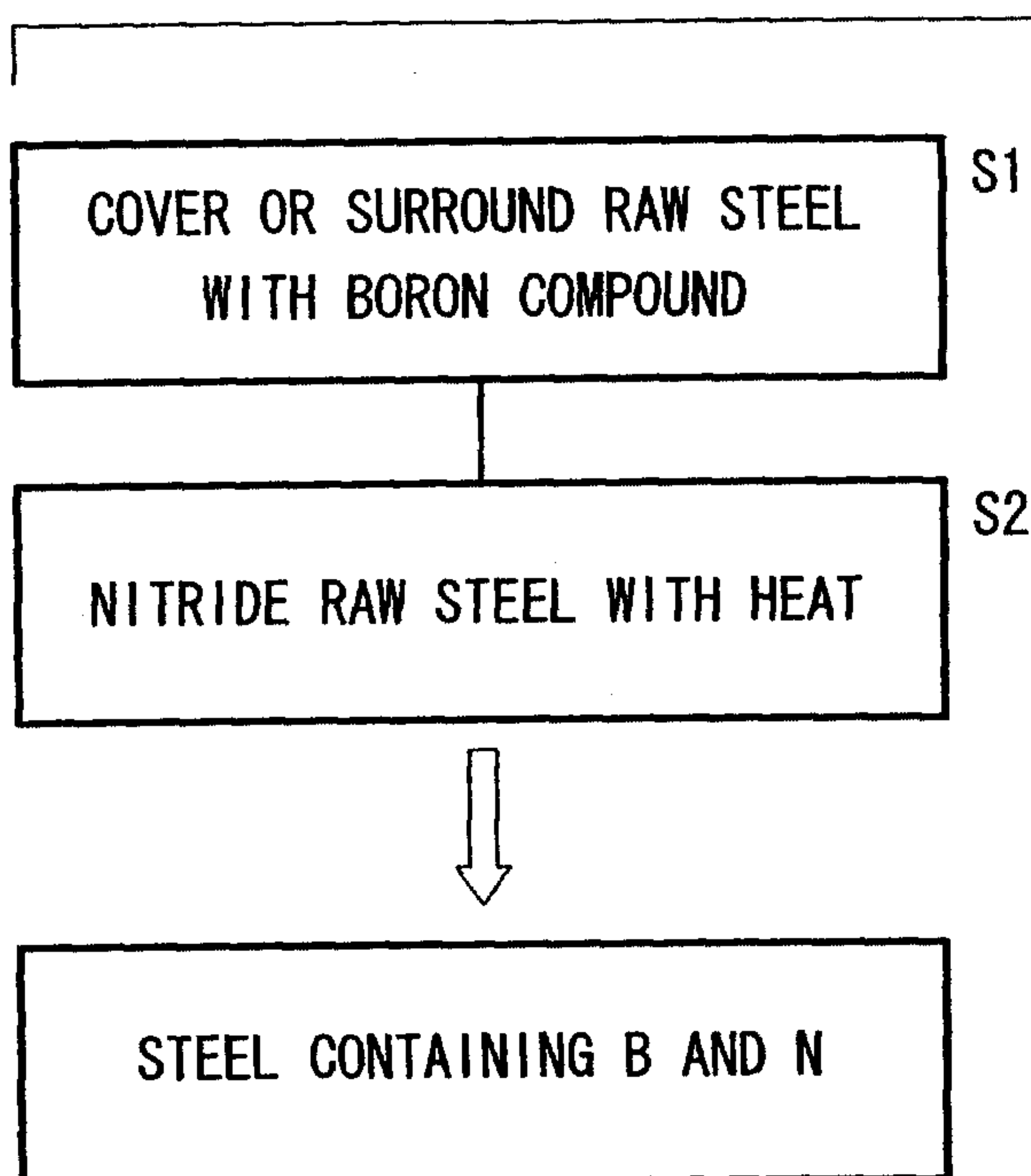

Marks & Clerk

FIG. 2

		VICKERS HARDNESS FROM ONE END TO THE OTHER										OTHER END FACE
		0.3 mm	0.5 mm	1.0 mm	2.0 mm	3.0 mm	5.0 mm	10 mm	20 mm	30 mm	40 mm	
\	INVENTIVE EXAMPLE 1	746	754	743	765	754	746	743	754	746	743	746
	INVENTIVE EXAMPLE 2	720	738	746	743	728	738	738	746	728	720	743

Marks & Clerk

3/9

FIG. 3

TEST PIECE	TENSILE STRENGTH (MPa)	CHARPY IMPACT VALUE (kgm/cm ²)
INVENTIVE EXAMPLE 1	1260	12.4
INVENTIVE EXAMPLE 2	1080	10.6
COMPARATIVE EXAMPLE 1	780	7.3

Marks & Clerk

FIG. 4

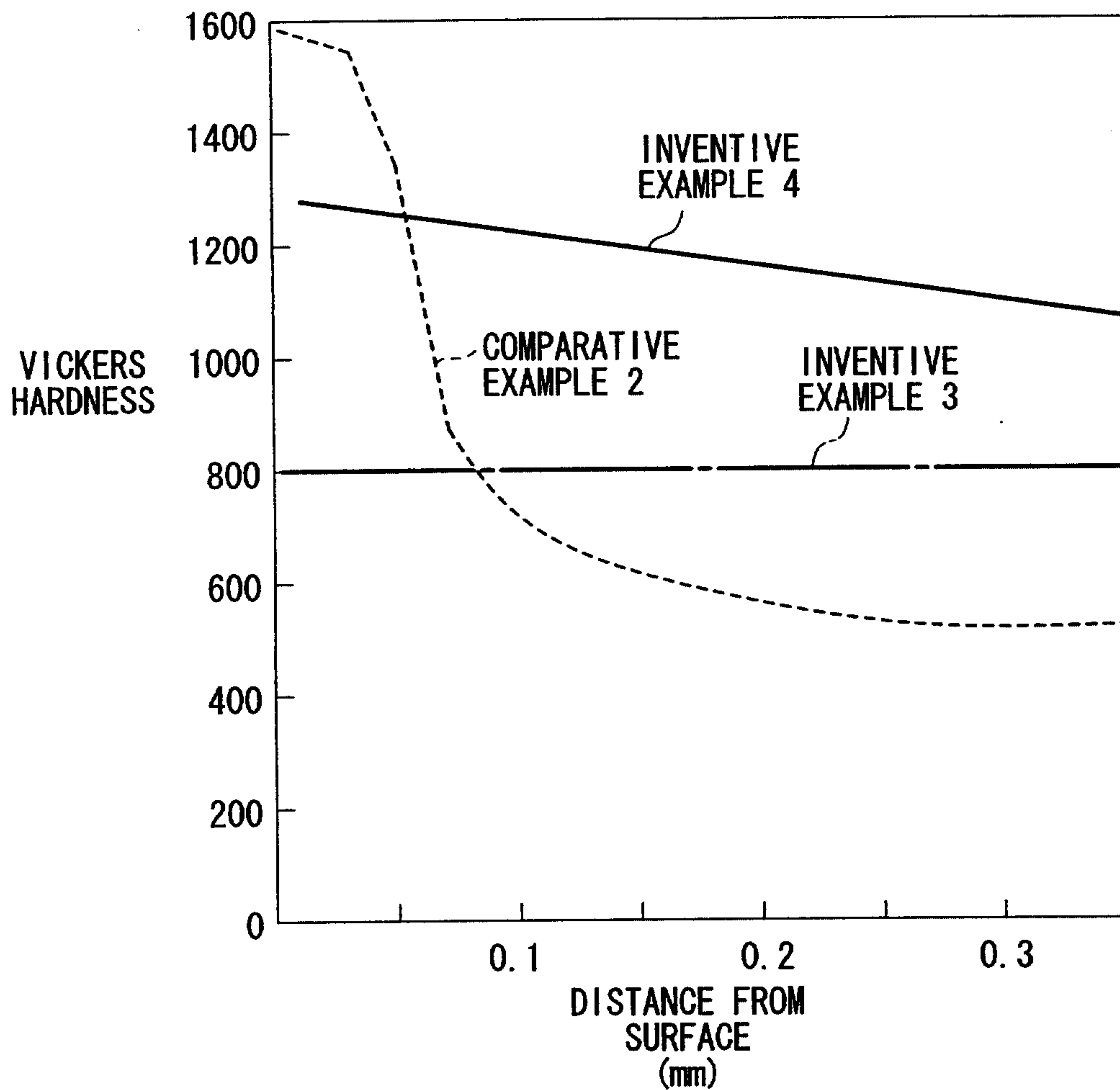

FIG. 5

HEAT-NITRIDING TIME (MIN.)	10 x 10*				20 x 20*				30 x 30*			
	B (ppm)	H _{RC}	TENSILE STRENGTH (MPa)	K _{IC}	B (ppm)	H _{RC}	TENSILE STRENGTH (MPa)	K _{IC}	B (ppm)	H _{RC}	TENSILE STRENGTH (MPa)	K _{IC}
5	14	66	-	-	14	66	-	-	14	66	-	-
10	14	66	-	-	14	66	-	-	14	66	-	-
15	15	67	-	-	14	66	-	-	14	66	-	-
20	15	67	-	-	14	67	-	-	14	66	-	-
30	16	67	-	-	15	67	-	-	14	66	-	-
45	16	67	-	-	15	67	-	-	15	66	-	-
60	17	67	-	-	16	67	-	-	15	67	-	-
80	17	67	-	-	17	67	-	-	15	67	-	-
120	18	68	-	-	17	67	-	-	16	67	-	-

* INDICATES LONGITUDINAL AND TRANSVERSE DIMENSIONS (mm)

Marks & Clerk

FIG. 6

HEAT-NITRIDING TIME (MIN.)	40 x 40*				50 x 50*				60 x 60*				70 x 70*			
	B (ppm)	H _{RC}	TENSILE STRENGTH (MPa)	K _{IC}	B (ppm)	H _{RC}	TENSILE STRENGTH (MPa)	K _{IC}	B (ppm)	H _{RC}	TENSILE STRENGTH (MPa)	K _{IC}	B (ppm)	H _{RC}	TENSILE STRENGTH (MPa)	K _{IC}
5	14	65	1480	62	14	65	1340	56	13	64	1280	52	13	63	1240	51
10	14	65	1460	60	14	65	1360	56	14	64	1240	52	13	63	1180	51
15	14	65	1460	61	14	65	1420	62	14	65	1340	57	14	63	1280	52
20	14	66	1580	67	14	66	1560	66	14	65	1460	61	14	64	1360	56
30	14	66	1640	74	14	66	1610	71	14	65	1480	62	14	65	1460	57
45	15	66	1680	75	14	66	1660	76	14	66	1650	74	14	65	1480	56
60	15	66	1680	75	15	66	1680	75	15	66	1680	76	15	65	1520	56
80	15	66	1470	56	15	66	1650	74	15	66	1640	74	15	66	1660	74
120	16	67	1380	47	16	67	1340	41	15	66	1650	74	15	66	1640	75

* INDICATES LONGITUDINAL AND TRANSVERSE DIMENSIONS (mm)

Marks & Clerk

7/9

FIG. 7

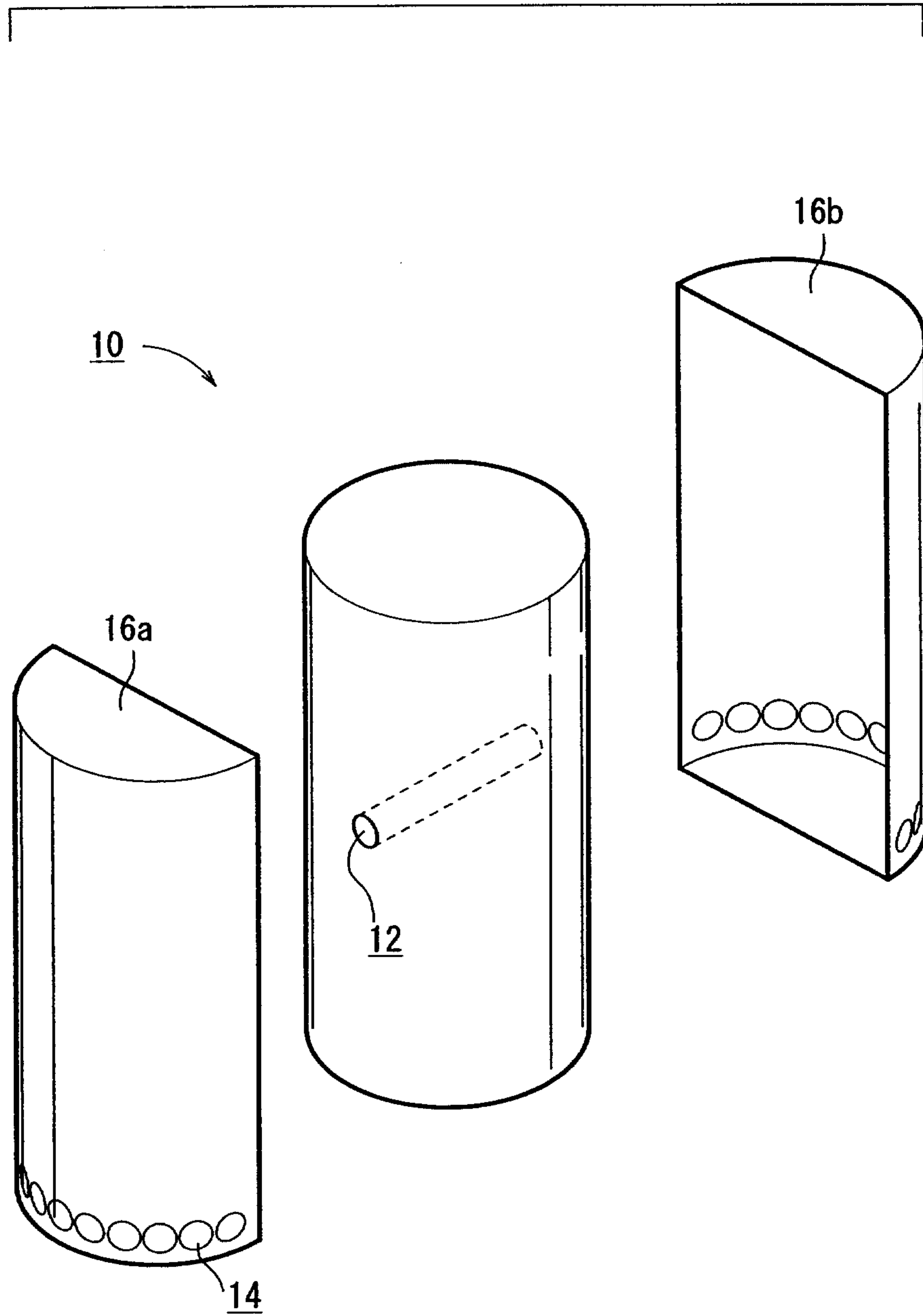

FIG. 8

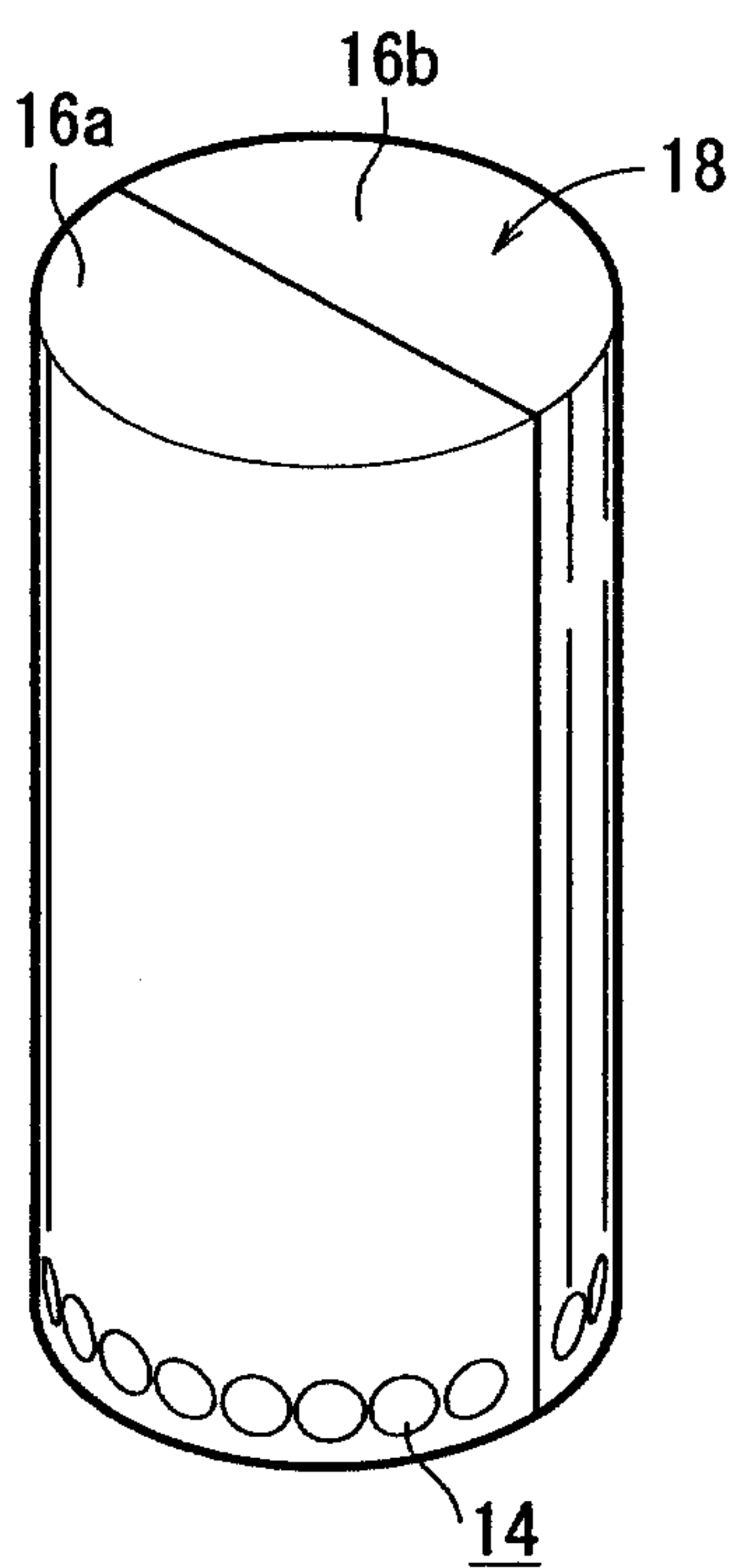
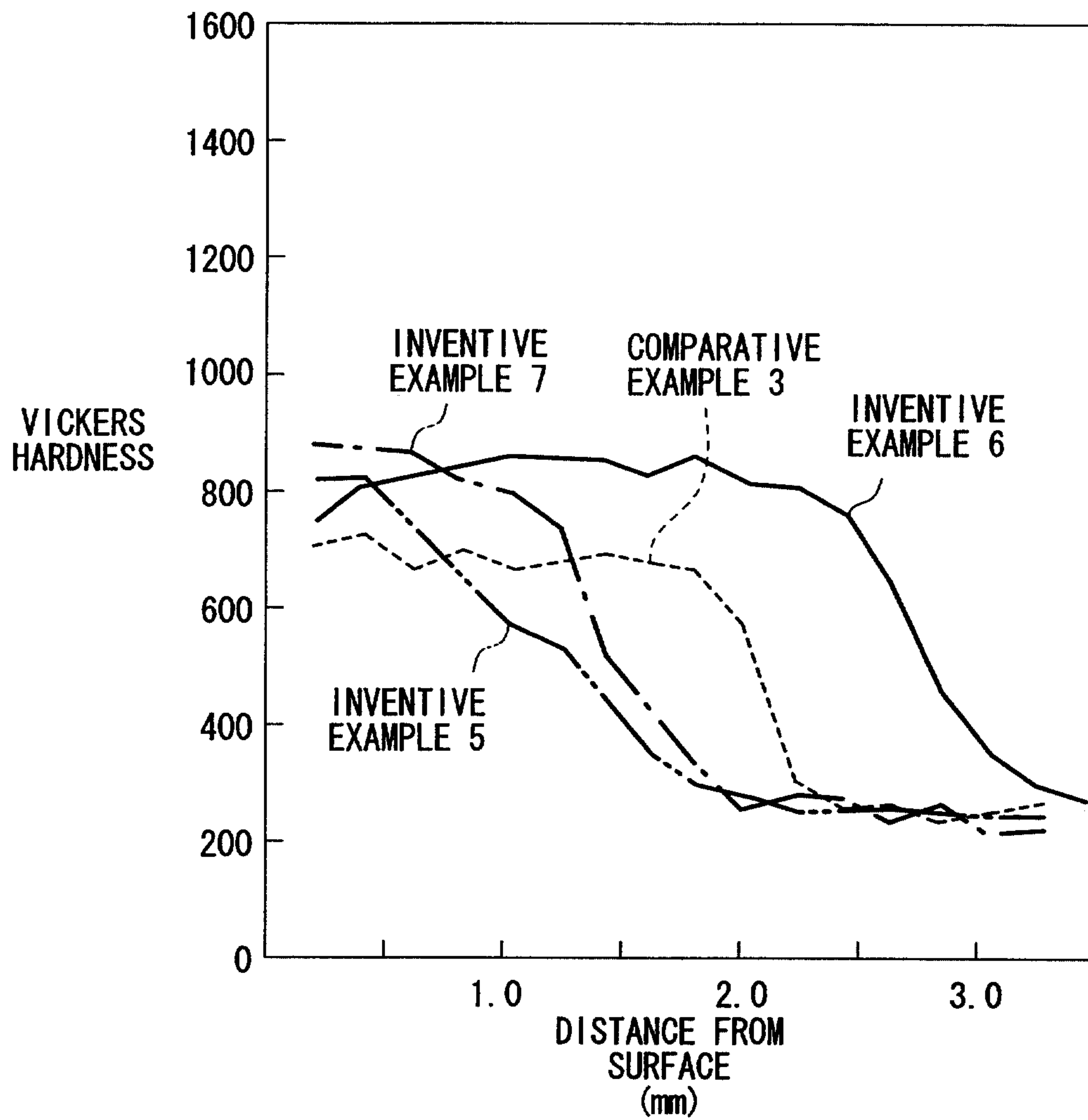

FIG. 9



COVER OR SURROUND RAW STEEL
WITH BORON COMPOUND

S1

NITRIDE RAW STEEL WITH HEAT

S2

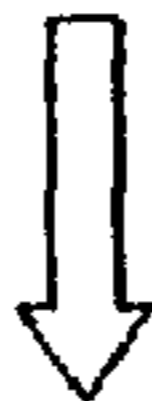

STEEL CONTAINING B AND N