

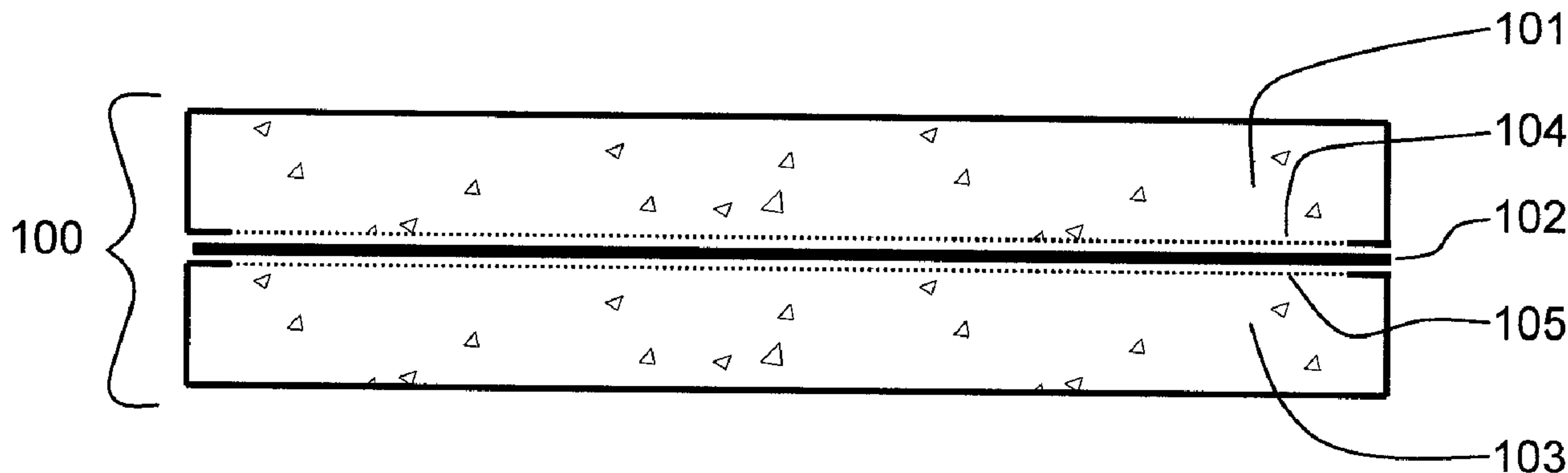

(86) **Date de dépôt PCT/PCT Filing Date:** 2008/04/07
 (87) **Date publication PCT/PCT Publication Date:** 2008/10/16
 (45) **Date de délivrance/Issue Date:** 2017/05/02
 (85) **Entrée phase nationale/National Entry:** 2009/10/06
 (86) **N° demande PCT/PCT Application No.:** US 2008/059540
 (87) **N° publication PCT/PCT Publication No.:** 2008/124672
 (30) **Priorité/Priority:** 2007/04/06 (US11/697,691)

(51) **Cl.Int./Int.Cl. E04B 1/86** (2006.01),
E04B 1/82 (2006.01), **E04C 2/284** (2006.01)
 (72) **Inventeur/Inventor:**
TINIANOV, BRANDON D., US
 (73) **Propriétaire/Owner:**
PACIFIC COAST BUILDING PRODUCTS, INC., US
 (74) **Agent:** SMART & BIGGAR

(54) **Titre : MATERIAU D'INSONORISATION ACOUSTIQUE AVEC CARACTERISTIQUES DE RUPTURE AMELIOREES ET
PROCEDES DE FABRICATION**
 (54) **Title: ACOUSTICAL SOUND PROOFING MATERIAL WITH IMPROVED FRACTURE CHARACTERISTICS AND METHODS FOR
MANUFACTURING SAME**



(57) **Abrégé/Abstract:**

A material for use in building construction (partition, wall, ceiling, floor or door) that exhibits improved acoustical sound proofing and fracture characteristics optimized for efficient installation. The material comprises a laminated structure having as an integral part thereof one or more layers of viscoelastic material which also functions both as a glue and as an energy dissipating layer; and one or more constraining layers, such as gypsum or cement-based panel products modified for easy fracture. In one embodiment, standard paper-faced wallboard, typically gypsum, comprises the external surfaces of the laminated structure with the inner surface of said wallboard being bare with no paper or other material being placed thereon. The resulting structure improves the attenuation of sound transmitted through the structure while also allowing installation of the sound proofing material as efficiently as the installation of standard material when the sound proofing material is used alone or incorporated into a partition assembly.

(12) INTERNATIONAL APPLICATION PUBLISHED UNDER THE PATENT COOPERATION TREATY (PCT)

(19) World Intellectual Property Organization
International Bureau



(43) International Publication Date
16 October 2008 (16.10.2008)

PCT

(10) International Publication Number
WO 2008/124672 A1

(51) International Patent Classification:
E04B 1/82 (2006.01)

(21) International Application Number:

PCT/US2008/059540

(22) International Filing Date: 7 April 2008 (07.04.2008)

(25) Filing Language: English

(26) Publication Language: English

(30) Priority Data:

11/697,691 6 April 2007 (06.04.2007) US

(71) Applicant (for all designated States except US): **SERIOUS MATERIALS, LLC** [US/US]; 1250 Elko Drive, Sunnyvale, California 94089 (US).

(72) Inventor; and

(75) Inventor/Applicant (for US only): **TINIANOV, Brandon, D.** [US/US]; 647 Monroe Street, Santa Clara, California 95050 (US).

(74) Agent: **MACPHERSON, Alan, H.**; MacPherson Kwok Chen & Heid LLP, 2033 Gateway Place, Suite 400, San Jose, California 95110 (US).

(81) Designated States (unless otherwise indicated, for every kind of national protection available): AE, AG, AL, AM, AO, AT, AU, AZ, BA, BB, BG, BH, BR, BW, BY, BZ, CA, CH, CN, CO, CR, CU, CZ, DE, DK, DM, DO, DZ, EC, EE, EG, ES, FI, GB, GD, GE, GH, GM, GT, HN, HR, HU, ID, IL, IN, IS, JP, KE, KG, KM, KN, KP, KR, KZ, LA, LC, LK, LR, LS, LT, LU, LY, MA, MD, ME, MG, MK, MN, MW, MX, MY, MZ, NA, NG, NI, NO, NZ, OM, PG, PH, PL, PT, RO, RS, RU, SC, SD, SE, SG, SK, SL, SM, SV, SY, TJ, TM, TN, TR, TT, TZ, UA, UG, US, UZ, VC, VN, ZA, ZM, ZW.

(84) Designated States (unless otherwise indicated, for every kind of regional protection available): ARIPO (BW, GH, GM, KE, LS, MW, MZ, NA, SD, SL, SZ, TZ, UG, ZM, ZW), Eurasian (AM, AZ, BY, KG, KZ, MD, RU, TJ, TM), European (AT, BE, BG, CH, CY, CZ, DE, DK, EE, ES, FI, FR, GB, GR, HR, HU, IE, IS, IT, LT, LU, LV, MC, MT, NL, NO, PL, PT, RO, SE, SI, SK, TR), OAPI (BF, BJ, CF, CG, CI, CM, GA, GN, GQ, GW, ML, MR, NE, SN, TD, TG).

Published:

- with international search report
- before the expiration of the time limit for amending the claims and to be republished in the event of receipt of amendments

(54) Title: ACOUSTICAL SOUND PROOFING MATERIAL WITH IMPROVED FRACTURE CHARACTERISTICS AND METHODS FOR MANUFACTURING SAME

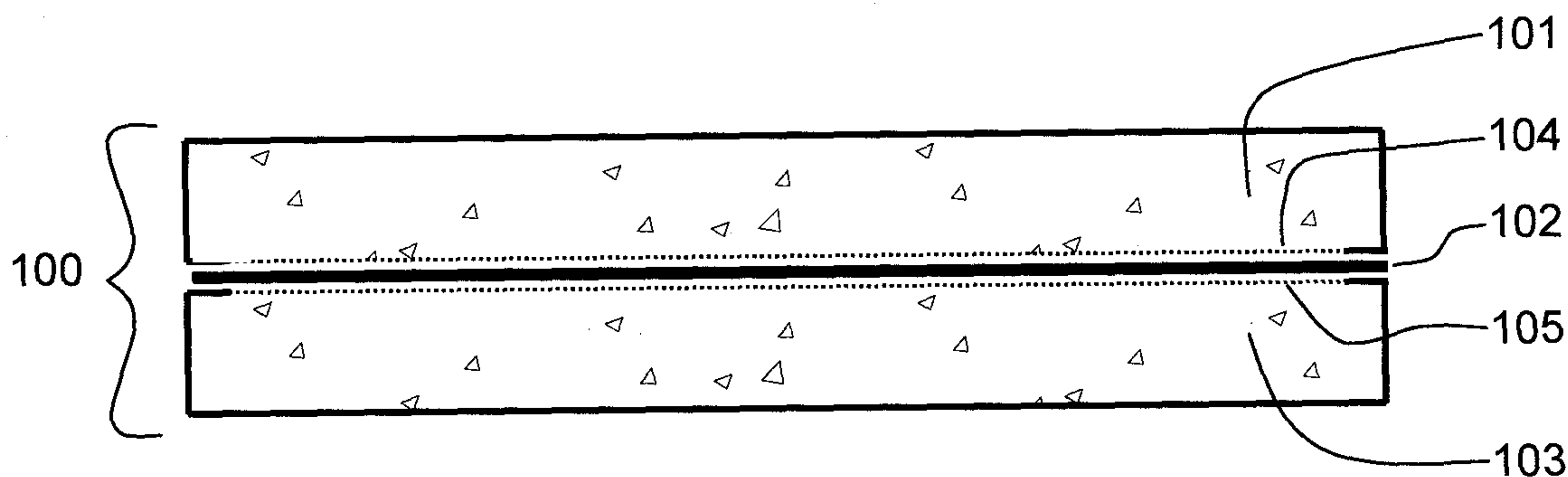

FIG. 1

(57) Abstract: A material for use in building construction (partition, wall, ceiling, floor or door) that exhibits improved acoustical sound proofing and fracture characteristics optimized for efficient installation. The material comprises a laminated structure having as an integral part thereof one or more layers of viscoelastic material which also functions both as a glue and as an energy dissipating layer; and one or more constraining layers, such as gypsum or cement-based panel products modified for easy fracture. In one embodiment, standard paper-faced wallboard, typically gypsum, comprises the external surfaces of the laminated structure with the inner surface of said wallboard being bare with no paper or other material being placed thereon. The resulting structure improves the attenuation of sound transmitted through the structure while also allowing installation of the sound proofing material as efficiently as the installation of standard material when the sound proofing material is used alone or incorporated into a partition assembly.



WO 2008/124672 A1

ACOUSTICAL SOUND PROOFING MATERIAL WITH IMPROVED FRACTURE CHARACTERISTICS AND METHODS FOR MANUFACTURING SAME

BACKGROUND

[0001] Noise control constitutes a rapidly growing economic and public policy concern for the construction industry. Areas with high acoustical isolation (commonly referred to as 'soundproofed') are requested and required for a variety of purposes. Apartments, condominiums, hotels, schools and hospitals all require walls, ceilings and floors that are specifically designed to reduce the transmission of sound in order to minimize or eliminate the disruption to people in adjacent rooms. Soundproofing is particularly important in buildings adjacent to public transportation including highways, airports and railroad lines. Additionally, theaters and home theaters, music practice rooms, recording studios and others require increased noise abatement for acceptable listening levels. Likewise, hospitals and general healthcare facilities have begun to recognize acoustical comfort as an important part of a patient's recovery time. One measure of the severity of multi-party residential and commercial noise control issues is the widespread emergence of model building codes and design guidelines that specify minimum Sound Transmission Class (STC) ratings for specific wall structures within a building. Another measure is the broad emergence of litigation between homeowners and builders over the issue of unacceptable noise levels. To the detriment of the U.S. economy, both problems have resulted in major builders refusing to build homes, condos and apartments in certain municipalities; and in cancellation of liability insurance for builders.

[0002] Various construction techniques and products have emerged to address the problem of noise control, such as: replacement of wooden framing studs with light gauge steel studs; alternative framing techniques such as staggered-stud and double-stud construction; additional gypsum drywall layers; the addition of resilient channels to offset and isolate drywall panels from framing studs; the addition of mass-loaded vinyl barriers; cellulose-based sound board; and the use of cellulose

and fiberglass batt insulation in walls not requiring thermal control. All of these changes help reduce the noise transmission but not to such an extent that certain disturbing noises (e.g., those with significant low frequency content or high sound pressure levels) in a given room are prevented from being transmitted to a room
5 designed for privacy or comfort. The noise may come from rooms above or below the occupied space, or from an outdoor noise source. In fact, several of the above named methods only offer a three to six decibel improvement in acoustical performance over that of standard construction techniques with no regard to acoustical isolation. Such a small improvement represents a just noticeable
10 difference, not a soundproofing solution. A second concern with the above named techniques is that each involves the burden of either additional (sometimes costly) construction materials or extra labor expense due to complicated designs and additional assembly steps.

[0003] More recently, an alternative building noise control product has been
15 introduced to the market in the form of a laminated damped drywall panel as disclosed in U.S. Pat. No. 7,181,891. That panel replaces a traditional drywall layer and eliminates the need for additional materials such as resilient channels, mass loaded vinyl barriers, additional stud framing, and additional layers of drywall. The resulting system offers excellent acoustical performance improvements of up to
20 15 decibels in some cases. However, the panel cannot be cut by scribing and breaking. Rather than using a box cutter or utility knife to score the panel for fracture by hand, the panels must be scored multiple times and broken with great force over the edge of a table or workbench. Often times, the quality of the resulting break (in terms of accuracy of placement and overall straightness) is
25 poor. The reason for the additional force required to fracture the laminated panel is because the component gypsum layers have a liner back paper (or liner fiberglass nonwoven) that has a high tensile strength. Tests have shown that scored panels of this type require approximately 85 pounds of force to fracture versus the 15 pounds required to break scored 1/2 inch thick standard gypsum wallboard and the
30 46 pounds of force required to break scored 5/8 inch thick type X gypsum wallboard. This internal layer (or layers, in some cases) must be broken under

tension via considerable bending force during a typical score and snap operation.

[0004] In many cases, the tradesman is forced to cut each panel with a power tool such as a circular saw or a rotary cutting tool to ensure a straight cut and a high quality installation. This adds time and labor costs to the panel installation and generates copious amounts of dust which act as a nuisance to the laborers and adds even more installation expense in the form of jobsite clean up.

[0005] A figure of merit for the sound reducing qualities of a material or method of construction is the material or wall assembly's Sound Transmission Class (STC). The STC rating is a classification which is used in the architectural field to rate partitions, doors and windows for their effectiveness in blocking sound. The rating assigned to a particular partition design as a result of acoustical testing represents a best fit type of approach to a curve that establishes the STC value. The test is conducted in such a way as to make it independent of the test environment and yields a number for the partition only and not its surrounding structure or environment. The measurement methods that determine an STC rating are defined by the American Society of Testing and Materials (ASTM). They are ASTM E 90, "Standard Test Method Laboratory Measurement of Airborne Sound Transmission Loss of Building Partitions and Elements," and ASTM E413 "Classification for Sound Insulation," used to calculate STC ratings from the sound transmission loss data for a given structure. These standards are available on the Internet at <http://www.astm.org>.

[0006] A second figure of merit for the physical characteristics of construction panels is the material's flexural strength. This refers to the panel's ability to resist breaking when a force is applied to the center of a simply supported panel. Values of flexural strength are given in pounds of force (lbf) or Newtons (N). The measurement technique used to establish the flexural strength of gypsum wallboard or similar construction panels is ASTM C 473 "Standard Test Methods for the Physical Testing of Gypsum Panel Products". This standard is available on the Internet at <http://www.astm.org>.

[0007] The desired flexural strength of a panel is dependant upon the situation. For a pristine panel, a high flexural strength is desirable since it allows for easy transportation and handling without panel breakage. However, when the panel is scored by the tradesman (for example, with a utility knife) for fitting and installation,
5 a low flexural strength is desirable. In that case, a low value indicates that the scored panel may be easily fractured by hand without excessive force.

[0008] Accordingly, what is needed is a new material and a new method of construction to reduce the transmission of sound from a given room to an adjacent area while simultaneously minimizing the materials required and the cost of
10 installation labor during construction.

SUMMARY

[0009] In accordance with the present invention, a new laminar structure and associated manufacturing process are disclosed which significantly improve both the material's installation efficiency and the ability of a wall, ceiling, floor or door to
15 reduce the transmission of sound from one architectural space (e.g. room) to an adjacent architectural space, or from the exterior to the interior of an architectural space (e.g. room), or from the interior to the exterior of an architectural space.

[0010] The material comprises a lamination of several different materials. In accordance with one embodiment, a laminar substitute for drywall comprises a
20 sandwich of two outer layers of selected thickness gypsum board, each lacking the standard liner back paper, which are glued to each other using a sound dissipating adhesive wherein the sound dissipating adhesive is applied over all of the interior surfaces of the two outer layers. In one embodiment, the glue layer is a specially formulated QuietGlue™, which is a viscoelastic material, of a specific thickness.
25 Formed on the interior surfaces of the two gypsum boards, the glue layer is about 1/32 inch thick. In one instance, a 4 foot x 8 foot panel constructed using a 1/32 inch thick layer of glue has a total thickness of approximately 1/2 inches and has a scored flexural strength of 22 pounds force and an STC value of approximately 38. A double-sided wall structure constructed using single wood studs, R13 fiberglass

77346-24

batts in the stud cavity, and the laminated panel screwed to each side provides an STC value of approximately 49. The result is a reduction in noise transmitted through the wall structure of approximately 15 decibels compared to the same structure using common (untreated) gypsum boards of equivalent mass and thickness.

5 **[0010a]** Some embodiments disclosed herein relate to a laminated, sound-attenuating structure for use in walls, ceilings, floors or other building partitions to attenuate sound which comprises: a first gypsum board having two surfaces, the first of said two surfaces comprising an outer, paper-clad surface and the second of said two surfaces comprising an inner, unclad surface; a layer of viscoelastic glue on the
10 second of said two surfaces; and a second gypsum board over said viscoelastic glue, said second gypsum board having two surfaces, the first of said two surfaces of said second gypsum board comprising an outer, paper-clad surface and the second of said two surfaces of said second gypsum board comprising an inner, unclad surface.

[0010b] Some embodiments disclosed herein relate to a laminated, sound-
15 attenuating structure for use in walls, ceilings, floors or other building partitions to attenuate sound which comprises: a first gypsum board having two surfaces, the first of said two surfaces comprising an outer, fiberglass nonwoven-clad surface and the second of said two surfaces comprising an inner, unclad surface; a layer of viscoelastic glue on the second of said two surfaces; and a second gypsum board over said
20 viscoelastic glue, said second gypsum board having two surfaces, the first of said two surfaces of said second gypsum board comprising an outer, paper-clad surface and the second of said two surfaces of said second gypsum board comprising an inner, unclad surface.

[0010c] Some embodiments disclosed herein relate to a laminated, sound-
25 attenuating structure for use in walls, ceilings, floors or other building partitions to attenuate sound which comprises: a gypsum board having two surfaces, the first of said two surfaces comprising an outer, paper-clad surface and the second of said two surfaces comprising an inner, unclad surface; a layer of viscoelastic glue on the second of said two surfaces; and a cement-based board over said viscoelastic glue, said

77346-24

cement-based board having two surfaces, the first of said two surfaces of said cement-based board comprising an outer surface and the second of said two surfaces of said cement-based board comprising an inner surface.

[0010d] Some embodiments disclosed herein relate to a laminated, sound-attenuating structure for use in walls, ceilings, floors or other building partitions to attenuate sound which comprises: a gypsum board having two surfaces, the first of said two surfaces comprising an outer, fiberglass nonwoven-clad surface and the second of said two surfaces comprising an inner, unclad surface; a layer of viscoelastic glue on the second of said two surfaces; and a cement-based board over said viscoelastic glue, said cement-based board having two surfaces, the first of said two surfaces of said cement-based board comprising an outer surface and the second of said two surfaces of said cement-based board comprising an inner surface.

BRIEF DESCRIPTION OF THE DRAWINGS

[0011] This invention will be more fully understood in light of the following drawings taken together with the following detailed description.

FIG. 1 shows a laminar structure fabricated in accordance with this invention for reducing the transmission of sound through the material while providing superior fracture characteristics.

FIG. 2 shows a second embodiment of a laminated structure containing five (5) layers of material capable of significantly reducing the transmission of sound through the material while providing superior fracture characteristics.

FIG. 3 shows flexural strength results for one sample embodiment of a laminar material constructed in accordance with the present invention.

FIG. 4 shows flexural strength results for several examples of drywall materials including typical drywall, laminated panels in current use, and the present invention.

77346-24

FIG. 5 shows a wall structure wherein one element of the structure comprises a laminar panel constructed in accordance with the present invention.

FIG. 6 graphically shows detailed results data of sound attenuation tests for an example embodiment of this invention and a typical wall of similar weight
5 and physical dimensions.

DESCRIPTION OF SOME EMBODIMENTS

[0012] The following detailed description is meant to be exemplary only and not

limiting. Other embodiments of this invention, such as the number, type, thickness, dimensions, area, shape, and placement order of both external and internal layer materials, will be obvious to those skilled in the art in view of this description.

5 [0013] The process for creating laminar panels in accordance with the present invention takes into account many factors: exact chemical composition of the glue; glue application process; pressing process; and drying and dehumidification process.

10 [0014] FIG. 1 shows the laminar structure of one embodiment of this invention. In FIG. 1, the layers in the structure will be described from top to bottom with the structure oriented horizontally as shown. It should be understood, however, that the laminar structure of this invention will be oriented vertically when placed on vertical walls, doors or other vertical partitions, as well as horizontally or even at an angle when placed on ceilings and floors. Therefore, the reference to top and bottom layers is to be understood to refer only to these layers as oriented in FIG. 1 and not in the context of the vertical use of this structure. In FIG. 1, the assembly
15 numerated as 100 refers to an entire laminated panel constructed in accordance with this invention. A top layer 101 is made up of a paper or fiberglass-faced gypsum material and in one embodiment is 1/4 inch thick. In one embodiment sixty (60) pound paper eighteen (18) mils thick is used. The resulting panel is 1/4 inch
20 plus eighteen (18) mils thick. Of course, many other combinations and thicknesses can be used for any of the layers as desired. The thicknesses are limited only by the acoustical attenuation (i.e., STC rating) desired for the resulting laminar structure and by the weight of the resulting structure which will limit the ability of workers to install the laminated panel on walls, ceilings, floors and doors for its
25 intended use.

[0015] The gypsum board in top layer 101 typically is fabricated using standard well-known techniques and thus the method for fabricating the gypsum board will not be described. Next, the bottom face of gypsum layer 101 is an unfaced (without paper or fiberglass liner) interior surface 104. In other embodiments,
30 surface 104 may be faced with a thin film or veil with a very low tensile strength. In

one embodiment this thin film or veil can be a single use healthcare fabric as described more completely below in paragraph 21. Applied to surface 104 is a layer of glue 102 called "QuietGlue™. Glue 102, made of a viscoelastic polymer, has the property that the kinetic energy in the sound which interacts with the glue, when constrained by surrounding layers, will be significantly dissipated by the glue thereby reducing the sound's total energy across a broad frequency spectrum, and thus the sound energy which will transmit through the resulting laminar structure. Typically, this glue 102 is made of the materials as set forth in TABLE 1, although other glues having similar characteristics to those set forth directly below TABLE 1 can also be used in this invention.

TABLE 1

Fire-Enhanced (FE) Quiet Glue™ Chemical Makeup

COMPONENTS	WEIGHT %		
	Min	Max	Preferred
acrylate polymer	30	70	41
ethyl acrylate, methacrylic acid, polymer with ethyl-2- propenoate	0	3.0	0.3
hydrophobic silica	0	1.0	0.2
paraffin oil	0	3.0	1.5
silicon dioxide	0	1.0	0.1
sodium carbonate	0	3.0	0.6
stearic acid, aluminum salt	0	1.0	0.1
surfactant	0	2.0	0.6
rosin ester	0	20	7
Zinc Borate	0	25	12
Melamine Phosphate	0	10	6
Ammonium Polyphosphate	0	10	6
Hexahydroxy methyl ethane	0	5.0	1.5
CI Pigment Red Dispersion	0	1.0	0.02
water	10	40	23
2-Pyridinethiol, 1- oxide, sodium salt	0	3.0	1

The preferred formulation is but one example of a viscoelastic glue. Other

formulations may be used to achieve similar results and the range given is an example of successful formulations investigated here.

[0016] The physical solid-state characteristics of QuietGlue™ include:

- 1) a broad glass transition temperature below room temperature;
- 5 2) mechanical response typical of a rubber (i.e., elongation at break, low elastic modulus);
- 3) strong peel strength at room temperature;
- 4) weak shear strength at room temperature;
- 6) does not dissolve in water (swells poorly); and
- 10 7) peels off the substrate easily at temperature of dry ice.

QuietGlue may be obtained from Serious Materials, 1259 Elko Drive, Sunnyvale, CA 94089.

[0017] Gypsum board layer 103 is placed on the bottom of the structure and carefully pressed in a controlled manner with respect to uniform pressure (pounds
15 per square inch), temperature and time. The top face of gypsum layer 103 is an unfaced (without paper or fiberglass liner) interior surface 105. In other embodiments, surface 105 may be faced with a thin film or veil with a very low tensile strength. The maximum very low tensile strength for the thin film or veil is approximately six (6) psi but the preferred very low tensile strength for this material
20 is as low as approximately one (1) psi. In one embodiment this thin film can be a fabric such as a single use healthcare fabric as described more completely in paragraph 21. Such fabrics are typically used for surgical drapes and gowns.

[0018] Finally, the assembly is subjected to dehumidification and drying to allow the panels to dry, typically for forty-eight (48) hours.

25 [0019] In one embodiment of this invention, the glue 102, when spread over the bottom of top layer 101, is subject to a gas flow for about forty-five seconds to

partially dry the glue. The gas can be heated, in which case the flow time may be reduced. The glue 102, when originally spread out over any material to which it is being applied, is liquid. By partially drying out the glue 102, either by air drying for a selected time or by providing a gas flow over the surface of the glue, the glue
5 102 becomes a pressure sensitive adhesive, much like the glue on a tape. The second panel, for example the bottom layer 103, is then placed over the glue 102 and pressed against the material beneath the glue 102 (as in the example of FIG. 1, top layer 101) for a selected time at a selected pressure. The gas flowing over the glue 102 can be, for example, air or dry nitrogen. The gas dehumidifies the
10 glue 102, improving manufacturing throughput compared to the pressing process described previously wherein the glue 102 is not dried for an appreciable time prior to placing layer 103 in place.

[0020] In FIG. 2, two external layers of gypsum board 201 and 203 have on their interior faces unfaced surfaces 206 and 207, respectively. Attached to these
15 are glue layers 204 and 205 respectively. Between the two glue layers 204 and 205 is a constraining layer 202 made up of polyester, non-woven fiber, or another low tensile strength material suitable for the application. The tensile strength of this constraining layer can be a maximum of approximately ten (10) psi but preferably is from approximately one (1) to three (3) psi.

20 [0021] Examples of materials for the constraining layer 202 include polyester non-wovens, fiberglass non-woven sheets, cellulosic nonwovens, or similar products. The tensile strength of these materials varies with the length of the constituent fibers and the strength of the fiber/binder bond. Those with shorter fibers and weaker bond strengths have lower tensile strengths. A good example of
25 such materials are the plastic-coated cellulosic nonwoven materials commonly used as single use healthcare fabrics, known for their poor tensile strengths. Single use healthcare fabrics are available from the 3M Corporation of St. Paul, MN, DuPont of Wilmington, DE and Ahlstrom of Helsinki, Finland. The preferred maximum very low tensile strength for these materials is approximately six (6) psi
30 but the preferred very low tensile strength for these materials is approximately one

(1) psi. The weight of these materials can vary from a high of approximately four (4) ounces per square yard down to a preferred weight of approximately eight tenths (0.8) of an ounce per square yard. Alternate materials can be of any type and any appropriate thickness with the condition that they have acceptably low tensile strength properties. In the example of FIG. 2, the constraining material 202 approximate covers the same area as the glue 204 and 205 to which it is applied.

[0022] FIG. 3 shows flexural strength test results for an embodiment wherein the interior surfaces (104 and 105) the gypsum sheets 101, 103 do not have an additional facing material such as paper. The sample tested was constructed consistent with FIG. 1, and had dimensions of 0.3 m by 0.41 m (12 inches by 16 inches) and a total thickness of 13 mm (0.5 inch). A three point bending load was applied to the sample according to ASTM test method C 473, bending test method B. The measured flexural strength was 22 pounds force.

[0023] The flexural strength value of the finished laminate 100 significantly decreases with the elimination of the paper facings at surfaces 104 and 105. FIG. 4 illustrates the relationship of two laminate embodiments and typical gypsum wallboard materials. As seen in FIG. 4, the currently available laminated panels G1 to G4 (QuietRock 510) have an average flexural strength of 85 pounds force when scored.

[0024] In comparison, scored typical prior art gypsum sheets (F1 to F4 and E1 to E4) with interior paper faced surfaces, have an average flexural strength of 15 pounds force for 1/2 inch thick and 46 pounds force for 5/8 inch thick respectively. These prior art laminated panels can be scored and fractured in the standard manner used in construction but lack the acoustic properties of the structures described herein. The other prior art structures shown in FIG. 4 (A1-A4 to D1-D4 and G1-G4) have an average peak load at fracture above fifty pounds force and thus are unacceptable materials for traditional fracture methods during installation. Of these prior art materials, QuietRock® (G1-G4) has improved sound attenuation properties but can not be scored and fractured using traditional scoring and breaking methods. The present invention (represented by H1 to H4) has a scored

flexural strength of 22 pounds force as shown in FIG. 3 and 4. and thus can be scored and fractured in the standard manner used in construction while at the same time providing an enhanced acoustical attenuation of sound compared to the prior art structures (except QuietRock).

5 [0025] FIG. 5 is an example of a wall structure comprising a laminated panel 508 constructed in accordance with the present invention (i.e., laminate 100 as shown in FIG. 1); wood studs 502, 504, and 506; batt-type insulation 512; and a 5/8 inch sheet of standard gypsum drywall 510, with their relationship shown in Section A-A. FIG. 6 shows the results of sound testing for a structure as in FIG. 5,
10 wherein the panel 508 is constructed as shown in FIG. 1. Sound attenuation value (STC number) of the structure is an STC of 49. It is known to those practicing in this field that a similar configuration with standard 5/8 inch drywall on both sides of standard 2 x 4 construction yields an STC of approximately 34. Accordingly, this invention yields a 15 STC point improvement over standard drywall in this
15 particular construction.

[0026] In fabricating the structure of FIG. 1, the glue 104 is first applied in a prescribed manner in a selected pattern, typically to 1/32 inch thickness, although other thicknesses can be used if desired, onto the top layer 101. The bottom layer 103 is placed over the top layer 101. Depending on the drying and
20 dehumidification techniques deployed, anywhere from five minutes to thirty hours are required to totally dry the glue in the case that the glue is water-based. A solvent-based viscoelastic glue can be substituted for the water-based glue. The solvent-based glue requires a drying time of about five (5) minutes in air at room temperature.

25 [0027] In fabricating the structure of FIG. 2, the method is similar to that described for the structure of FIG. 1. However, before the bottom layer 203 is applied (bottom layer 203 corresponds to bottom layer 103 in FIG. 1) the constraining material 202 is placed over the glue 204. A second layer of glue 205 is applied to the surface of the constraining material 202 on the side of the
30 constraining material 202 that is facing away from the top layer 201. In one

embodiment the glue layer 205 is applied to the interior side of bottom layer 203 instead of being applied to layer 202. The bottom layer 203 is placed over the stack of layers 201, 204, 202 and 205. The resulting structure is dried in a prescribed manner under a pressure of approximately two to five pounds per square inch, depending on the exact requirements of each assembly, although
5 other pressures may be used as desired.

[0028] Accordingly, the laminated structures of this invention provide a significant improvement in the sound transmission class number associated with the structures and thus reduce significantly the sound transmitted from one room
10 to adjacent rooms while simultaneously providing for traditional scoring and hand fracture during installation.

[0029] The dimensions given for each material in the laminated structures of this invention can be varied as desired to control cost, overall thickness, weight, anticipated moisture and temperature control requirements, and STC results. The described embodiments and their dimensions are illustrative only and not limiting.
15 Other materials than gypsum can be used for one or both of the external layers of the laminated structures shown in FIGS. 1 and 2. For example, the layer 103 of the laminated structure 100 shown in FIG.1 and the layer 203 of the laminated structure 200 shown in FIG.2 can be formed of cement or of a cement-based
20 material in a well known manner. The cement-based material can include calcium silicate, magnesium oxide and/or phosphate or combinations thereof.

[0030] Other embodiments of this invention will be obvious in view of the above description.

77346-24

CLAIMS:

1. A laminated, sound-attenuating structure for use in walls, ceilings, floors or other building partitions to attenuate sound which comprises:

5 a first gypsum board having two surfaces, the first of said two surfaces comprising an outer, paper-clad surface and the second of said two surfaces comprising an inner, unclad surface;

a layer of viscoelastic glue on the second of said two surfaces; and

10 a second gypsum board over said viscoelastic glue, said second gypsum board having two surfaces, the first of said two surfaces of said second gypsum board comprising an outer, paper-clad surface and the second of said two surfaces of said second gypsum board comprising an inner, unclad surface.

2. A laminated, sound-attenuating structure for use in walls, ceilings, floors or other building partitions to attenuate sound which comprises:

15 a first gypsum board having two surfaces, the first of said two surfaces comprising an outer, fiberglass nonwoven-clad surface and the second of said two surfaces comprising an inner, unclad surface;

a layer of viscoelastic glue on the second of said two surfaces; and

20 a second gypsum board over said viscoelastic glue, said second gypsum board having two surfaces, the first of said two surfaces of said second gypsum board comprising an outer, paper-clad surface and the second of said two surfaces of said second gypsum board comprising an inner, unclad surface.

3. A laminated, sound-attenuating structure for use in walls, ceilings, floors or other building partitions to attenuate sound which comprises: a gypsum board having two surfaces, the first of said two surfaces comprising an outer, paper-clad surface and
25 the second of said two surfaces comprising an inner, unclad surface;

77346-24

a layer of viscoelastic glue on the second of said two surfaces; and

a cement-based board over said viscoelastic glue, said cement-based board having two surfaces, the first of said two surfaces of said cement-based board comprising an outer surface and the second of said two surfaces of said cement-based
5 board comprising an inner surface.

4. A laminated, sound-attenuating structure of Claim 3, wherein the cement-based board comprises a calcium silicate board; and

wherein said structure is appropriate for use in walls, ceilings, floors or other building partitions to attenuate sound.

10 5. A laminated, sound-attenuating structure as in Claim 3, wherein the cement-based board comprises a magnesium oxide-based board; and

wherein said structure is appropriate for use in walls, ceilings, floors or other building partitions to attenuate sound.

15 6. A laminated, sound-attenuating structure as in Claim 3, wherein the cement-based board comprises a phosphate-based cement board; and

wherein said structure is appropriate for use in walls, ceilings, floors or other building partitions to attenuate sound.

7. A laminated, sound-attenuating structure for use in walls, ceilings, floors or other building partitions to attenuate sound which comprises:

20 a gypsum board having two surfaces, the first of said two surfaces comprising an outer, fiberglass nonwoven-clad surface and the second of said two surfaces comprising an inner, unclad surface;

a layer of viscoelastic glue on the second of said two surfaces; and

77346-24

a cement-based board over said viscoelastic glue, said cement-based board having two surfaces, the first of said two surfaces of said cement-based board comprising an outer surface and the second of said two surfaces of said cement-based board comprising an inner surface.

- 5 8. A laminated, sound-attenuating structure as in Claim 7, wherein the cement-based board comprises a calcium silicate board; and

wherein said structure is appropriate for use in walls, ceilings, floors or other building partitions to attenuate sound.

9. A laminated, sound-attenuating structure as in Claim 7, wherein the
10 cement-based board comprises a magnesium oxide-based board; and

wherein said structure is appropriate for use in walls, ceilings, floors or other building partitions to attenuate sound.

10. A laminated, sound-attenuating structure as in Claim 7, wherein the cement-based board comprises a phosphate-based cement board; and

- 15 wherein said structure is appropriate for use in walls, ceilings, floors or other building partitions to attenuate sound.

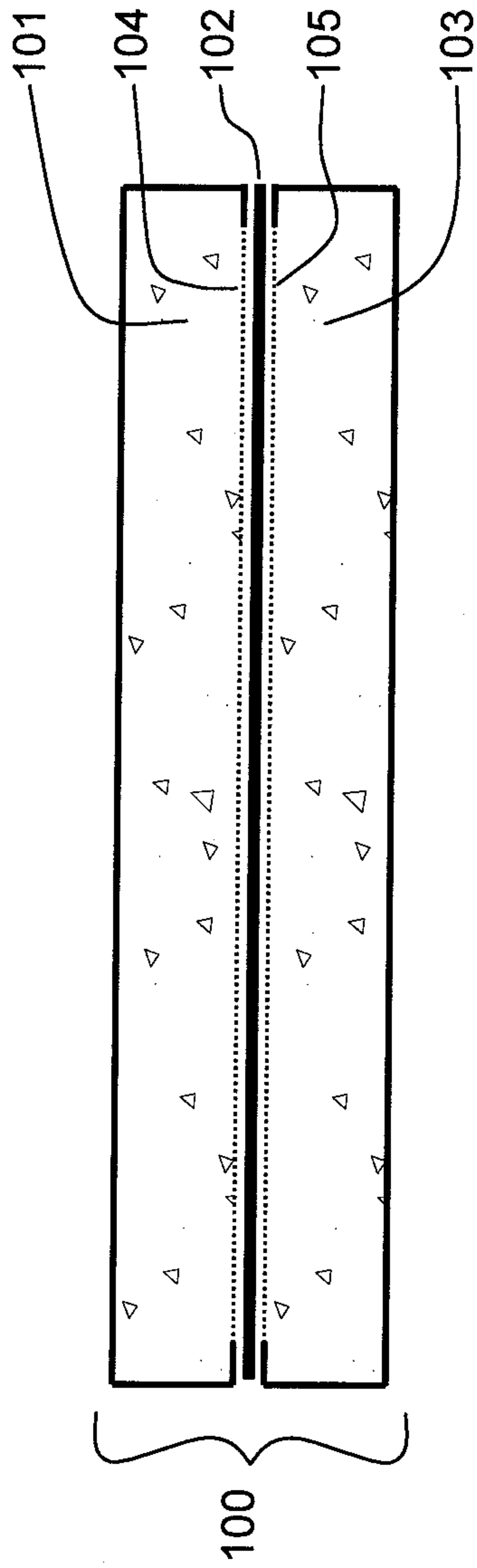

FIG. 1

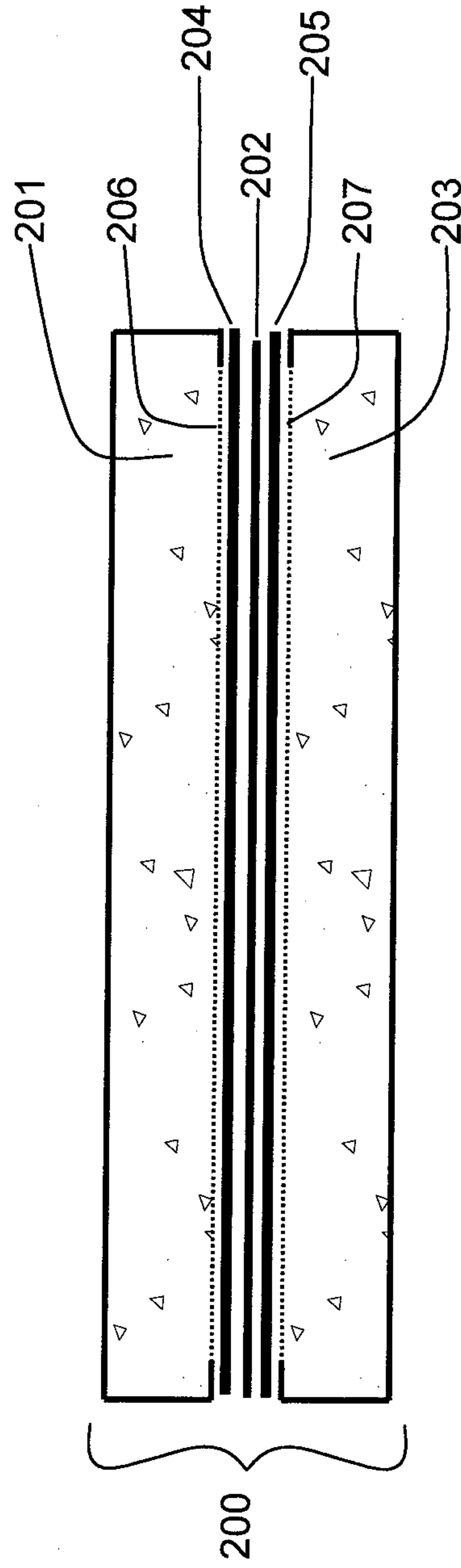

FIG. 2

**ASTM C473 Flexural strength test results for a
laminated wallboard**

Sample Number	Sample Description	Peak Load at Fracture (lbf)
H1	1/2 inch thick laminated gyp panel optimized for fracture	24.1
H2	1/2 inch thick laminated gyp panel optimized for fracture	21.7
H3	1/2 inch thick laminated gyp panel optimized for fracture	19.8
H4	1/2 inch thick laminated gyp panel optimized for fracture	22.4
Average		22.0
Standard Deviation		1.82

FIG. 3

**ASTM C473 flexural strength test results for various
wallboard types and conditions**

Series Identification	Sample Description	Average Peak Load at Fracture (lbf)	Standard Deviation
A1 - A4	5/8 inch thick gypsum panel	204	2.99
B1 - B4	1/2 inch thick gypsum panel	147	3.10
C1 - C4	1/2 inch thick QuietRock 510 laminated gypsum panel	164	4.90
D1 - D4	1/2 inch thick laminated gyp panel optimized for fracture	111	8.34
E1 - E4	5/8 inch thick gypsum panel, scored	46.3	4.65
F1 - F4	1/2 inch thick gypsum panel, scored	15.0	0.50
G1 - G4	1/2 inch thick QuietRock 510 laminated gypsum panel, scored	84.5	3.30
H1 - H4	1/2 inch thick laminated gyp panel optimized for fracture, scored	22.0	1.82

FIG. 4

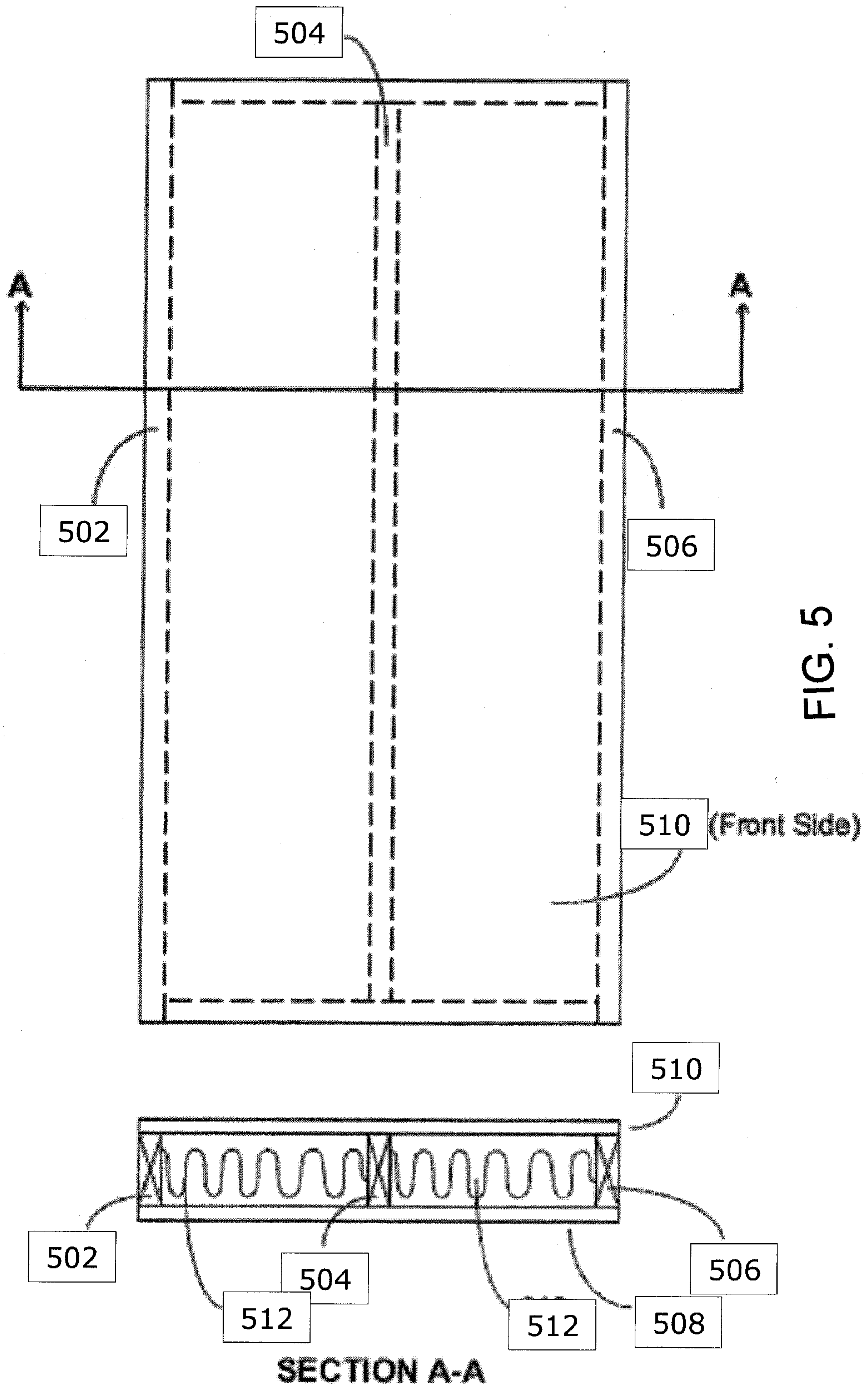

FIG. 5

ASTM E90 transmission loss curves for a two wall assemblies using different wallboard types

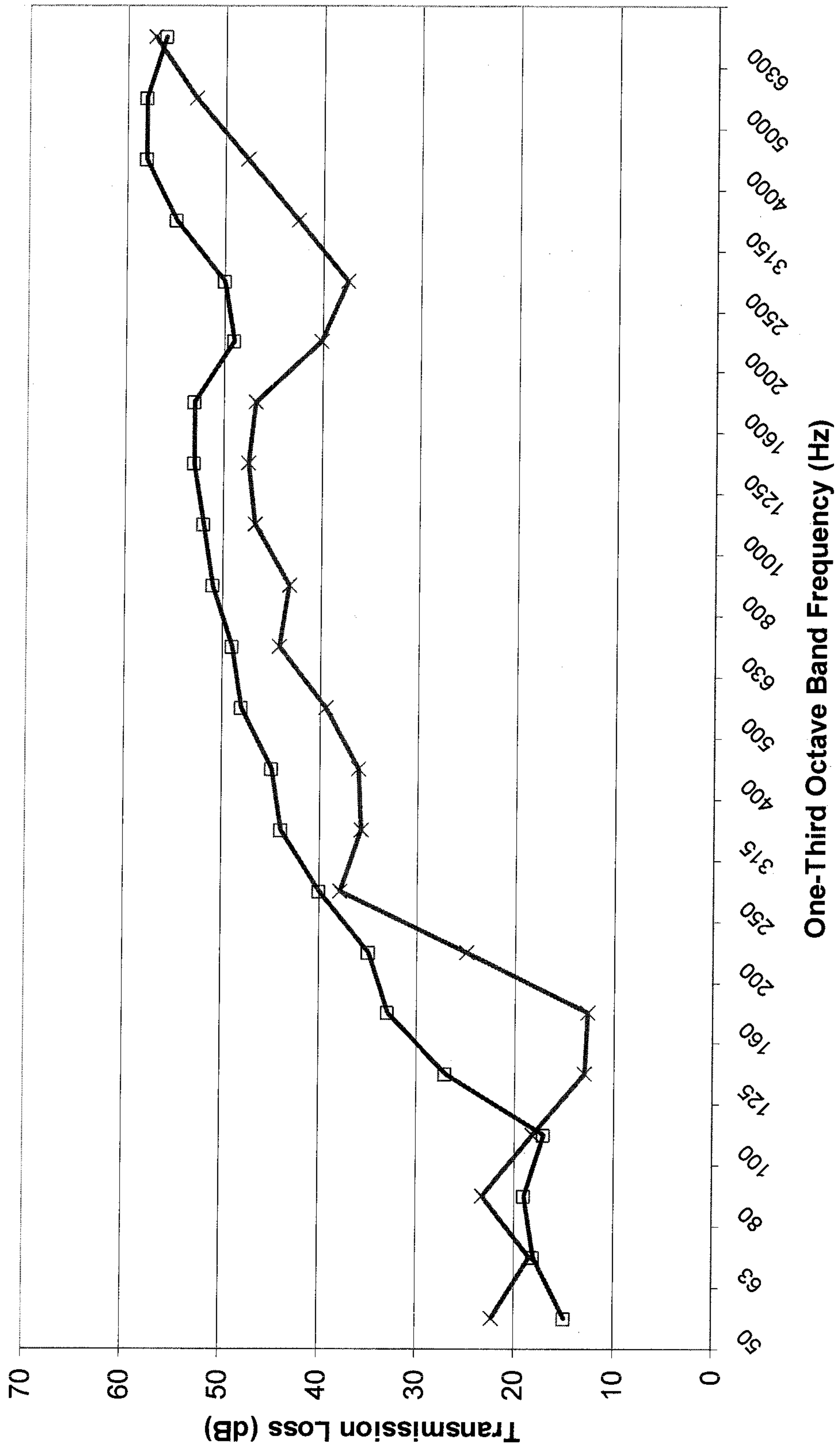

FIG. 6

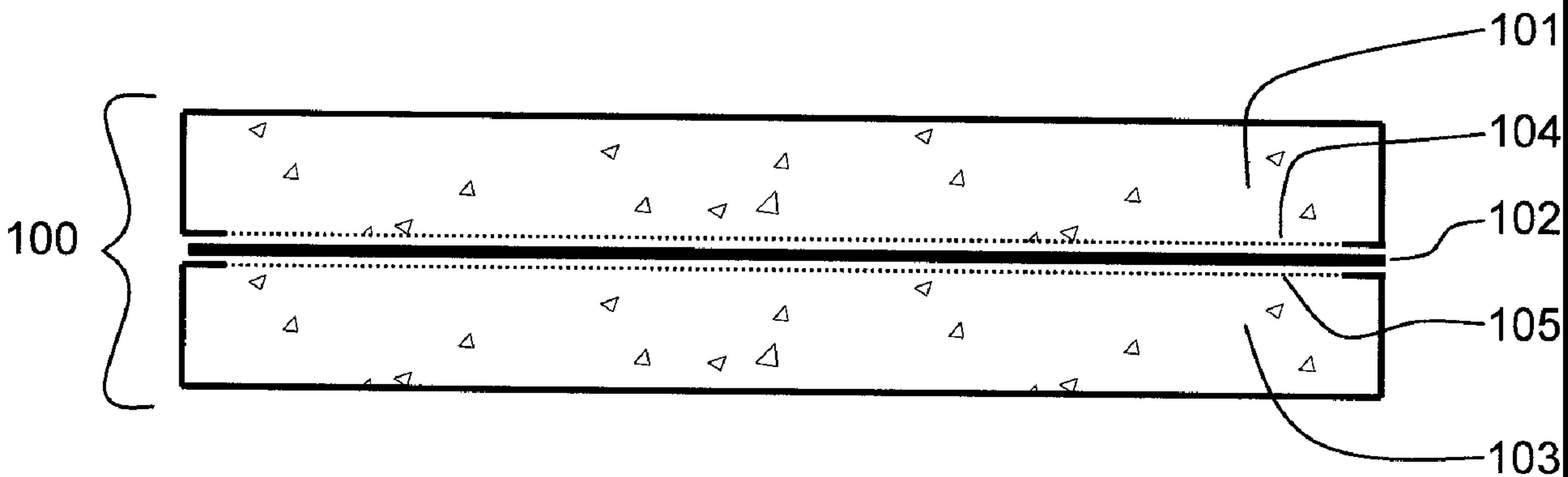

FIG. 1