



(11) **EP 3 128 123 A2**

(12) **EUROPEAN PATENT APPLICATION**

(43) Date of publication:
08.02.2017 Bulletin 2017/06

(51) Int Cl.:
E21B 43/12^(2006.01)

(21) Application number: **16183114.4**

(22) Date of filing: **05.08.2016**

(84) Designated Contracting States:
AL AT BE BG CH CY CZ DE DK EE ES FI FR GB GR HR HU IE IS IT LI LT LU LV MC MK MT NL NO PL PT RO RS SE SI SK SM TR
Designated Extension States:
BA ME
Designated Validation States:
MA MD

(72) Inventors:
• **SCHMITT, Kenneth J.**
Houston, TX Texas TX 77041 (US)
• **ROBISON, Clark E.**
Houston, TX Texas TX 77041 (US)
• **MCDONALD, Robert G.**
Shenandoah, TX Texas TX 77385 (US)
• **TRAPANI, James. S**
Houston, TX Texas TX 77056 (US)
• **THOMAS, Benson**
Katy, TX Texas TX 77493 (US)

(30) Priority: **05.08.2015 PCT/US2015/043694**
02.12.2015 US 201514956545
02.12.2015 US 201514956527
02.12.2015 US 201514956601
02.12.2015 US 201514956863

(74) Representative: **Hagmann-Smith, Martin P.**
Marks & Clerk LLP
Fletcher House
Heatley Road
The Oxford Science Park
Oxford OX4 4GE (GB)

(71) Applicants:
• **Weatherford Technology Holdings, LLC**
Houston, TX 77056 (US)
• **Amfields, LP**
Houston, TX 77073 (US)

(54) **PUMPING SYSTEM AND METHOD**

(57) A hydraulic pumping system can include a hydraulic actuator with a magnet that displaces with a piston, and a sensor that continuously detects a position of the magnet. A ferromagnetic wall of the hydraulic actuator is positioned between the magnet and the sensor. A hydraulic pumping method can include incrementally lowering a lower stroke extent of a rod string reciprocation over multiple reciprocation cycles of the rod string, and automatically varying the lower stroke extent or an upper stroke extent of the rod string reciprocation, in response to a measured vibration. Another hydraulic pumping method can include solving a wave equation in the rod string, and automatically varying a reciprocation speed of the rod string in response to a change in work performed during reciprocation cycles of the hydraulic actuator or a change in detected force versus displacement in different reciprocation cycles of the hydraulic actuator.

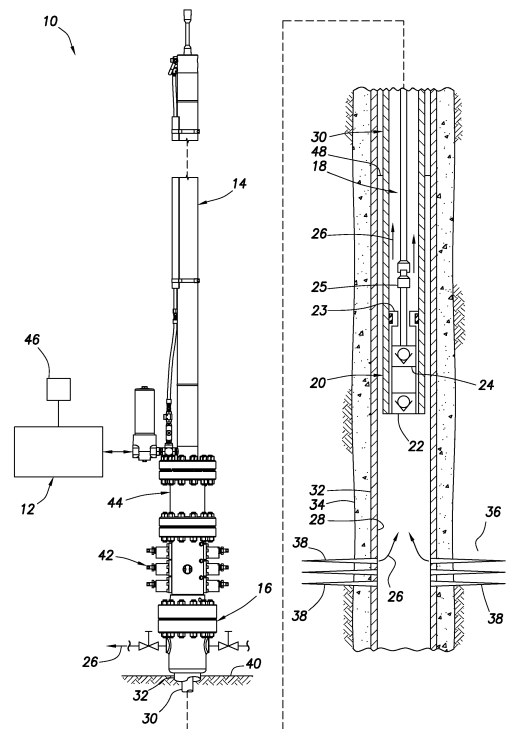

FIG.1

EP 3 128 123 A2

Description**CROSS-REFERENCE TO RELATED APPLICATION**

[0001] This application claims priority from US 14/956,527, US 14/956,545, US 14/956,601, US 14/956,863 and PCT/US15/43694. The entire disclosure of the prior applications is incorporated herein by this reference for all purposes.

BACKGROUND

[0002] This disclosure relates generally to equipment utilized and operations performed in conjunction with a subterranean well and, in one example described below, more particularly provides a hydraulic pumping system, such as a hydraulic pumping system with piston displacement sensing and control.

[0003] Reservoir fluids can sometimes flow to the earth's surface when a well has been completed. However, with some wells, reservoir pressure may be insufficient (at the time of well completion or thereafter) to lift the fluids (in particular, liquids) to the surface. In those circumstances, technology known as "artificial lift" can be employed to bring the fluids to the surface (or other desired location, such as a subsea production facility or pipeline, etc.).

[0004] Various types of artificial lift technology are known to those skilled in the art. In one type of artificial lift, a downhole pump is operated by reciprocating a string of "sucker" rods deployed in a well. An apparatus (such as, a walking beam-type pump jack or a hydraulic actuator) located at the surface can be used to reciprocate the rod string.

[0005] The inventors have appreciated that improvements are continually needed in the arts of constructing and operating artificial lift systems. Such improvements may be useful for lifting oil, water, gas condensate or other liquids from wells, may be useful with various types of wells (such as, gas production wells, oil production wells, water or steam flooded oil wells, geothermal wells, etc.), and may be useful for any other application where reciprocating motion is desired.

BRIEF DESCRIPTION OF THE DRAWINGS**[0006]**

FIG. 1 is a representative partially cross-sectional view of an example of a hydraulic pumping system and associated method which can embody principles of this disclosure.

FIG. 2 is a representative cross-sectional view of an example of a hydraulic actuator that may be used in the system and method of FIG. 1.

FIG. 3 is a representative cross-sectional view of an

example piston position sensing technique that may be used in the system and method of FIG. 1.

FIG. 4 is a representative cross-sectional view of an example lower portion of the hydraulic actuator and an annular seal housing.

FIG. 5 is a representative top view of an example of a hydraulic pressure source that may be used in the system and method of FIG. 1.

FIG. 6 is a representative diagram of an example of a gas balancing assembly that may be used in the system and method of FIG. 1.

FIG. 7 is an example process and instrumentation diagram for the hydraulic pressure source of FIG. 5.

FIGS. 8A & B are representative examples of load versus displacement graphs for the system and method of FIG. 1.

FIG. 9 is a representative cross-sectional view of another example of the hydraulic actuator with a continuous position sensor.

FIG. 10 is a representative cross-sectional view of a downhole pump and rod string in the system and method.

DETAILED DESCRIPTION

[0007] Representatively illustrated in FIG. 1 is a hydraulic pumping system 10 and associated method for use with a subterranean well, which system and method can embody principles of this disclosure. However, it should be clearly understood that the hydraulic pumping system 10 and method are merely one example of an application of the principles of this disclosure in practice, and a wide variety of other examples are possible. Therefore, the scope of this disclosure is not limited at all to the details of the system 10 and method as described herein or depicted in the drawings.

[0008] In the FIG. 1 example, a hydraulic pressure source 12 is used to apply hydraulic pressure to, and exchange hydraulic fluid with, a hydraulic actuator 14 mounted on a wellhead 16. In response, the hydraulic actuator 14 reciprocates a rod string 18 extending into the well, thereby operating a downhole pump 20.

[0009] The rod string 18 may be made up of individual sucker rods connected to each other, although other types of rods or tubes may be used, the rod string 18 may be continuous or segmented, a material of the rod string 18 may comprise steel, composites or other materials, and elements other than rods may be included in the string. Thus, the scope of this disclosure is not limited to use of any particular type of rod string, or to use of a rod string at all. It is only necessary for purposes of this

disclosure to communicate reciprocating motion of the hydraulic actuator 14 to the downhole pump 20, and it is therefore within the scope of this disclosure to use any structure capable of such transmission.

[0010] The downhole pump 20 is depicted in FIG. 1 as being of the type having a stationary or "standing" valve 22 and a reciprocating or "traveling" valve 24. The traveling valve 24 is connected to, and reciprocates with, the rod string 18, so that fluid 26 is pumped from a wellbore 28 into a production tubing string 30. However, it should be clearly understood that the downhole pump 20 is merely one example of a wide variety of different types of pumps that may be used with the hydraulic pumping system 10 and method of FIG. 1, and so the scope of this disclosure is not limited to any of the details of the downhole pump described herein or depicted in the drawings.

[0011] The wellbore 28 is depicted in FIG. 1 as being generally vertical, and as being lined with casing 32 and cement 34. In other examples, a section of the wellbore 28 in which the pump 20 is disposed may be generally horizontal or otherwise inclined at any angle relative to vertical, and the wellbore section may not be cased or may not be cemented. Thus, the scope of this disclosure is not limited to use of the hydraulic pumping system 10 and method with any particular wellbore configuration.

[0012] In the FIG. 1 example, the fluid 26 originates from an earth formation 36 penetrated by the wellbore 28. The fluid 26 flows into the wellbore 28 via perforations 38 extending through the casing 32 and cement 34. The fluid 26 can be a liquid, such as oil, gas condensate, water, etc. However, the scope of this disclosure is not limited to use of the hydraulic pumping system 10 and method with any particular type of fluid, or to any particular origin of the fluid.

[0013] As depicted in FIG. 1, the casing 32 and the production tubing string 30 extend upward to the wellhead 16 at or near the earth's surface 40 (such as, at a land-based wellsite, a subsea production facility, a floating rig, etc.). The production tubing string 30 can be hung off in the wellhead 16, for example, using a tubing hanger (not shown). Although only a single string of the casing 32 is illustrated in FIG. 1 for clarity, in practice multiple casing strings and optionally one or more liner (a liner string being a pipe that extends from a selected depth in the wellbore 28 to a shallower depth, typically sealingly "hung off" inside another pipe or casing) strings may be installed in the well.

[0014] In the FIG. 1 example, a rod blowout preventer stack 42 and an annular seal housing 44 are connected between the hydraulic actuator 14 and the wellhead 16. The rod blowout preventer stack 42 includes various types of blowout preventers (BOP's) configured for use with the rod string 18. For example, one blowout preventer can prevent flow through the blowout preventer stack 42 when the rod string 18 is not present therein, and another blowout preventer can prevent flow through the blowout preventer stack 42 when the rod string 18 is

present therein. However, the scope of this disclosure is not limited to use of any particular type or configuration of blowout preventer stack with the hydraulic pumping system 10 and method of FIG. 1.

[0015] The annular seal housing 44 includes an annular seal (described more fully below) about a piston rod of the hydraulic actuator 14. The piston rod (also described more fully below) connects to the rod string 18 below the annular seal, although in other examples a connection between the piston rod and the rod string 18 may be otherwise positioned.

[0016] The hydraulic pressure source 12 may be connected directly to the hydraulic actuator 14, or it may be positioned remotely from the hydraulic actuator 14 and connected with, for example, suitable hydraulic hoses or pipes. Operation of the hydraulic pressure source 12 is controlled by a control system 46.

[0017] The control system 46 may allow for manual or automatic operation of the hydraulic pressure source 12, based on operator inputs and measurements taken by various sensors. The control system 46 may be separate from, or incorporated into, the hydraulic pressure source 12. In one example, at least part of the control system 46 could be remotely located or web-based, with two-way communication between the hydraulic pressure source 12 and the control system 46 being via, for example, satellite, wireless or wired transmission.

[0018] The control system 46 can include various components, such as a programmable controller, input devices (e.g., a keyboard, a touchpad, a data port, etc.), output devices (e.g., a monitor, a printer, a recorder, a data port, indicator lights, alert or alarm devices, etc.), a processor, software (e.g., an automation program, customized programs or routines, etc.) or any other components suitable for use in controlling operation of the hydraulic pressure source 12. The scope of this disclosure is not limited to any particular type or configuration of a control system.

[0019] In operation of the hydraulic pumping system 10 of FIG. 1, the control system 46 causes the hydraulic pressure source 12 to increase pressure applied to the hydraulic actuator 14 (delivering a volume of hydraulic fluid into the hydraulic actuator), in order to raise the rod string 18. Conversely, the hydraulic pressure source 12 receives a volume of hydraulic fluid from the hydraulic actuator 14 (thereby decreasing pressure applied to the hydraulic actuator), in order to allow the rod string 18 to descend. Thus, by alternately increasing and decreasing pressure in the hydraulic actuator 14, the rod string 18 is reciprocated, the downhole pump 20 is actuated and the fluid 26 is pumped out of the well.

[0020] Note that, when pressure in the hydraulic actuator 14 is decreased to allow the rod string 18 to displace downward (as viewed in FIG. 1), the pressure is not decreased to zero gauge pressure (e.g., atmospheric pressure). Instead, a "balance" pressure is maintained in the hydraulic actuator 14 to nominally offset a load due to the rod string 18 being suspended in the well (e.g., a

weight of the rod string, taking account of buoyancy, inclination of the wellbore 28, friction, well pressure, etc.).

[0021] In this manner, the hydraulic pressure source 12 is not required to increase pressure in the hydraulic actuator 14 from zero to that necessary to displace the rod string 18 upwardly (along with the displaced fluid 26), and then reduce the pressure back to zero, for each reciprocation of the rod string 18. Instead, the hydraulic pressure source 12 only has to increase pressure in the hydraulic actuator 14 sufficiently greater than the balance pressure to displace the rod string 18 to its upper stroke extent, and then reduce the pressure in the hydraulic actuator 14 back to the balance pressure to allow the rod string 18 to displace back to its lower stroke extent.

[0022] Note that it is not necessary for the balance pressure in the hydraulic actuator 14 to exactly offset the load exerted by the rod string 18. In some examples, it may be advantageous for the balance pressure to be somewhat less than that needed to offset the load exerted by the rod string 18. In addition, it can be advantageous in some examples for the balance pressure to change over time. Thus, the scope of this disclosure is not limited to use of any particular or fixed balance pressure, or to any particular relationship between the balance pressure, any other force or pressure and/or time.

[0023] A reciprocation speed of the rod string 18 will affect a flow rate of the fluid 26. Generally speaking, the faster the reciprocation speed at a given length of stroke of the rod string 18, the greater the flow rate of the fluid 26 from the well (to a point).

[0024] It can be advantageous to control the reciprocation speed, instead of reciprocating the rod string 18 as fast as possible. For example, a fluid interface 48 in the wellbore 28 can be affected by the flow rate of the fluid 26 from the well. The fluid interface 48 could be an interface between oil and water, gas and water, gas and gas condensate, gas and oil, steam and water, or any other fluids or combination of fluids.

[0025] If the flow rate is too great, the fluid interface 48 may descend in the wellbore 28, so that eventually the pump 20 will no longer be able to pump the fluid 26 (a condition known to those skilled in the art as "pump-off"). On the other hand, it is typically desirable for the flow rate of the fluid 26 to be at a maximum level that does not result in pump-off. In addition, a desired flow rate of the fluid 26 may change over time (for example, due to depletion of a reservoir, changed offset well conditions, water or steam flooding characteristics, etc.).

[0026] A "gas-locked" downhole pump 20 can result from a pump-off condition, whereby gas is received into the downhole pump 20. The gas is alternately expanded and compressed in the downhole pump 20 as the traveling valve 24 reciprocates, but the fluid 26 cannot flow into the downhole pump 20, due to the gas therein.

[0027] In the FIG. 1 hydraulic pumping system 10 and method, the control system 46 can automatically control operation of the hydraulic pressure source 12 to regulate the reciprocation speed, so that pump-off is avoided,

while achieving any of various desirable objectives. Those objectives may include maximum flow rate of the fluid 26, optimized rate of electrical power consumption, reduction of peak electrical loading, etc. However, it should be clearly understood that the scope of this disclosure is not limited to pursuing or achieving any particular objective or combination of objectives via automatic reciprocation speed regulation by the control system 46.

[0028] As mentioned above, the hydraulic pressure source 12 controls pressure in the hydraulic actuator 14, so that the rod string 18 is displaced alternately to its upper and lower stroke extents. These extents do not necessarily correspond to maximum possible upper and lower displacement limits of the rod string 18 or the pump 20.

[0029] For example, it is typically undesirable for a valve rod bushing 25 above the traveling valve 24 to impact a valve rod guide 23 above the standing valve 22 when the rod string 18 displaces downwardly (a condition known to those skilled in the art as "pump-pound"). Thus, it is preferred that the rod string 18 be displaced downwardly only until the valve rod bushing 25 is near its maximum possible lower displacement limit, so that it does not impact the valve rod guide 23.

[0030] On the other hand, the longer the stroke distance (without impact), the greater the productivity and efficiency of the pumping operation (within practical limits), and the greater the compression of fluid between the standing and traveling valves 22, 24 (e.g., to avoid gas-lock). In addition, a desired stroke of the rod string 18 may change over time (for example, due to gradual lengthening of the rod string 18 as a result of lowering of a liquid level (such as at fluid interface 48) in the well, etc.).

[0031] In the FIG. 1 hydraulic pumping system 10 and method, the control system 46 can automatically control operation of the hydraulic pressure source 12 to regulate the upper and lower stroke extents of the rod string 18, so that pump-pound is avoided, while achieving any of various desirable objectives. Those objectives may include maximizing rod string stroke length, maximizing production, minimizing electrical power consumption rate, minimizing peak electrical loading, etc. However, it should be clearly understood that the scope of this disclosure is not limited to pursuing or achieving any particular objective or combination of objectives via automatic stroke extent regulation by the control system 46.

[0032] Referring additionally now to FIG. 2, an enlarged scale cross-sectional view of an example of the hydraulic actuator 14 as used in the hydraulic pumping system 10 is representatively illustrated. Note that the hydraulic actuator 14 of FIG. 2 may be used with other systems and methods, in keeping with the principles of this disclosure.

[0033] As depicted in FIG. 2, the hydraulic actuator 14 includes a generally tubular cylinder 50, a piston 52 sealingly and reciprocally disposed in the cylinder 50, and a piston rod 54 connected to the piston 52. The piston 52

and piston rod 54 displace relative to the cylinder 50 in response to a pressure differential applied across the piston 52.

[0034] Hydraulic fluid and pressure are communicated between the hydraulic pressure source 12 and an annular chamber 56 in the cylinder 50 below the piston 52 via a port 58. A vent valve 60 is connected via a tubing 62 to an upper chamber 64 above the piston 52. The upper chamber 64 is maintained at substantially atmospheric pressure (zero gauge pressure), and pressure in the annular chamber 56 is controlled by the hydraulic pressure source 12, in order to control displacement of the piston 52 and piston rod 54 (and the rod string 18 connected thereto).

[0035] Note that, in this example, an annular seal assembly 66 is sealingly received in a lower flange 68 of the hydraulic actuator 14. The annular seal assembly 66 also sealingly engages an outer surface of the piston rod 54. Thus, a lower end of the annular chamber 56 is sealed off by the annular seal assembly 66.

[0036] In FIG. 2, the piston 52 is at a maximum possible upper limit of displacement. However, during a pumping operation, the piston 52 may not be displaced to this maximum possible upper limit of displacement. For example, as discussed above, an upper stroke extent of the rod string 18 may be regulated to achieve various objectives.

[0037] Similarly, during a pumping operation, the piston 52 also may not be displaced to a maximum possible lower limit of displacement. As described more fully below, upper and lower extents of displacement of the piston 52 and rod 54 can be varied to produce corresponding changes in the upper and lower stroke extents of the rod string 18, in order to achieve various objectives (such as, preventing pump-off, preventing pump-pound, optimizing pumping efficiency, reducing peak electrical loading, etc.).

[0038] Referring additionally now to FIG. 3, a further enlarged scale cross-sectional view of an upper portion of the hydraulic actuator 14 is representatively illustrated. This view is rotated somewhat about a vertical axis of the hydraulic actuator 14 (as compared to FIG. 2), so that a sensor 70, for example, a magnetic field sensor, is visible in FIG. 3.

[0039] The sensor 70 is secured to an outer surface of the cylinder 50 (for example, using a band clamp). In other examples, the sensor 70 could be bonded, threaded or otherwise attached to the cylinder 50, or could be incorporated into the cylinder or another component of the hydraulic actuator 14.

[0040] In some examples, a position of the sensor 70 relative to the cylinder 50 can be adjustable. The sensor 70 could be movable longitudinally along the cylinder 50, for example, via a threaded rod or another type of linear actuator.

[0041] A suitable magnetic field sensor is a Pepperl MB-F32-A2 magnetic flux sensing switch marketed by Pepperl+Fuchs North America of Twinsburg, Ohio USA. However, other magnetic field sensors may be used in

keeping with the principles of this disclosure.

[0042] The sensor 70 (when a magnetic field sensor is used) is capable of sensing a presence of a magnet 72 through a wall 74 of the cylinder 50. The magnet 72 is secured to, and displaces with, the piston 52. In some examples, the sensor 70 can sense the presence of the magnet 72, even though the wall 74 comprises a ferromagnetic material (such as steel), and even though the wall is relatively thick (such as, approximately 1.27 cm or greater thickness).

[0043] A suitable magnet for use in the actuator 14 is a neodymium magnet (such as, a neodymium-iron-boron magnet) in ring form. However, other types and shapes of magnets may be used in keeping with the principles of this disclosure.

[0044] Although only one sensor 70 is visible in FIG. 3, it is contemplated that any number of sensors could be used with the hydraulic actuator 14. The sensors 70 could be distributed in a variety of different manners along the cylinder 50 (e.g., linearly, helically, evenly spaced, unevenly spaced, etc.).

[0045] In the FIG. 3 example, an output of the sensor 70 is communicated to the control system 46, so that a position of the piston 52 at any given point in the pumping operation is determinable. As the number of sensors 70 is increased, determination of the position of the piston 52 at any given point in the pumping operation can become more accurate.

[0046] For example, two of the sensors 70 could be positioned on the cylinder 50, with one sensor at a position corresponding to an upper stroke extent of the piston 52 and magnet 72, and the other sensor at a position corresponding to a lower stroke extent of the piston and magnet. When a sensor 70 detects that the piston 52 and magnet 72 have displaced to the corresponding stroke extent (by sensing the proximate presence of the magnet 72), the control system 46 appropriately reverses the stroke direction of the piston 52 by operation of hydraulic components to be described further below. In this example, the upper and lower stroke extents of the piston 52 can be conveniently varied by adjusting the longitudinal positions of the sensors 70 on the cylinder 50.

[0047] Referring additionally now to FIG. 4, a cross-sectional view of a lower portion of the hydraulic actuator 14, the annular seal housing 44 and an upper flange of the BOP stack 42 is representatively illustrated. In this view, a threaded connection 76 between the piston rod 54 and the rod string 18 can be seen in the annular seal housing 44 below an annular seal assembly 78.

[0048] The annular seal assembly 78 seals off an annular space between the exterior surface of the piston rod 54 and an interior surface of the annular seal housing 44. The annular seal assembly 78 is similar in some respects to the annular seal assembly 66 in the hydraulic actuator 14, but the annular seal assembly 78 shown in FIG. 4 is exposed to pressure in the well (when the rod BOP's are not actuated), whereas the annular seal assembly (66 in FIG. 3) is exposed to pressure in the an-

nular chamber (56 in FIG. 3) of the hydraulic actuator 14.

[0049] A lubricant injector 80 slowly pumps grease or another lubricant 86 into an annular chamber 82 formed in the lower flange 68 of the hydraulic actuator 14 and an upper flange 84 of the annular seal housing 44. The lubricant 86 flows out of the annular chamber 82 to a reservoir 88. In one example, the lubricant 86 could be sourced from the hydraulic fluid in the annular chamber (56 in FIG. 3) or the hydraulic pressure source (12 in FIG. 1).

[0050] An advantage of having the lubricant 86 flow through the annular chamber 82 is that, if well fluid leaks past the annular seal assembly 78, or if hydraulic fluid leaks past the annular seal assembly (66 in FIG. 3), it will be apparent in the lubricant delivered to the reservoir 88. However, it is not necessary for the lubricant injector 80 to deliver pressurized lubricant 86 into the annular chamber 82 in keeping with the scope of this disclosure. For example, the lubricant 86 could instead be delivered from an unpressurized reservoir by gravity flow, etc.

[0051] An advantage of having the annular seal assemblies 66, 78 in the flanges 68, 84 is that they are both accessible by separating the flanges 68, 84 (for example, when the hydraulic actuator 14 is removed from the annular seal housing 44 for periodic maintenance). However, it should be clearly understood that the scope of this disclosure is not limited to pursuing or achieving any particular advantage, objective or combination of objectives by the hydraulic pumping system 10, hydraulic actuator 14, hydraulic pressure source 12 or annular seal housing 44.

[0052] Referring additionally now to FIG. 5, a top view of an example of the hydraulic pressure source 12 is representatively illustrated. In this view, a top cover of the hydraulic pressure source 12 is not illustrated, so that internal components of the hydraulic pressure source 12 are visible.

[0053] In the FIG. 5 example, the hydraulic pressure source 12 includes a prime mover 90, a primary hydraulic pump 92, an accessory hydraulic pump 94, a hydraulic fluid reservoir 96, a hydraulic fluid heat radiator 98 with fan 100, a nitrogen concentrator assembly 102, and a gas balancing assembly 104. The control system 46 is included with the hydraulic pressure source 12 in this example.

[0054] The prime mover 90 can be a fixed or variable speed electric motor (or any other suitable type of motor or engine). Preferably, the control system 46 controls operation of the prime mover 90 in an efficient manner that minimizes a cost of supplying electricity or fuel to the prime mover 90. This efficient manner may vary, depending on, for example, how a local electric utility company charges for electrical service (e.g., by peak load or by kilowatt hours used). Instead of an electric motor, the prime mover 90 could in other examples be an internal combustion engine, a turbine or positive displacement motor rotated by flow of gas from the well, or any other type of engine or motor. The type of prime mover is not

in any way intended to limit the scope of this disclosure.

[0055] The primary hydraulic pump 92 is driven by the prime mover 90 and supplies hydraulic fluid 106 under pressure from the gas balancing assembly 104 to the hydraulic actuator 14, in order to raise the piston 52 (and piston rod 54 and rod string 18). A filter 108 filters the hydraulic fluid 106 that flows from the hydraulic actuator 14 to the primary hydraulic pump 92 (flow from the pump to the actuator bypasses the filter).

[0056] When the piston 52 (and piston rod 54 and rod string 18) descends, the hydraulic fluid 106 flows back through the primary hydraulic pump 92 to the gas balancing assembly 104. In some examples, this "reverse" flow of the hydraulic fluid 106 can cause a rotor in the prime mover 90 to rotate "backward" and thereby generate electrical power. In such examples, this generated electrical power may be used to offset a portion of the electrical power consumed by the prime mover 90, in order to reduce the cost of supplying electricity to the prime mover. However, the scope of this disclosure is not limited to generation of electrical power by reverse flow of the hydraulic fluid 106 through the primary hydraulic pump 92.

[0057] The accessory hydraulic pump 94 can be used to initially charge the gas balancing assembly 104 with the hydraulic fluid 106 and circulate the hydraulic fluid 106 through the radiator 98. The nitrogen concentrator assembly 102 is used to produce pressurized and concentrated nitrogen gas by removal of oxygen from air (that is, non-cryogenically). In other examples, cryogenic nitrogen or another inert gas source could be used instead of, or in addition to, the nitrogen concentrator assembly 102.

[0058] The nitrogen concentrator assembly 102 pressurizes the gas balancing assembly 104 and thereby causes the balance pressure discussed above to be applied to the hydraulic actuator 14. The balance pressure can be varied by control of the nitrogen concentrator assembly 102 by the control system 46. As described more fully below, the control system 46 controls operation of the nitrogen concentrator assembly 102 in response to various operator inputs and sensor measurements.

[0059] Referring additionally now to FIG. 6, a schematic view of an example of the gas balancing assembly 104 is representatively illustrated with the nitrogen concentrator assembly 102. In this view, it may be seen that the gas balancing assembly 104 includes one or more gas volumes 110 that receive pressurized nitrogen from the nitrogen concentrator assembly 102. The nitrogen concentrator assembly 102 includes a membrane filter 112 and a compressor 114 in this example.

[0060] A total volume of the gas volumes 110 can be varied, depending on well conditions, anticipated pressures, a stroke length and piston area of the piston (52 in FIG. 3), etc. Although three gas volumes 110 are depicted in FIG. 6, any number of gas volumes may be used, as desired.

[0061] The gas balancing assembly 104 also includes

an accumulator 116 connected to the gas volumes 110. Thus, in this example, an upper portion of the accumulator 116 has the pressurized nitrogen gas 118 therein. In other examples, the gas volumes 110 could be combined with the accumulator 116.

[0062] A lower portion of the accumulator 116 has the hydraulic fluid 106 therein. Thus, the accumulator 116 is of the type known to those skilled in the art as a "gas over liquid" accumulator. However, in this example, there is no barrier (such as, a bladder or piston) separating the nitrogen gas 118 from the hydraulic fluid 106 in the accumulator 116. Thus, the hydraulic fluid 106 is in direct contact with the nitrogen gas 118 in the accumulator 116, and maintenance requirements for the accumulator 116 are reduced or eliminated (due at least to the absence of a barrier between the nitrogen gas 118 and the hydraulic fluid 106).

[0063] A suitable hydraulic fluid for use in the accumulator 116 in direct contact with the nitrogen gas 118 is a polyalkylene glycol (PAG) synthetic oil, such as SYN-LUBE P12 marketed by American Chemical Technologies, Inc. of Fowlerville, Michigan USA. However, other enhancements thereof and other hydraulic fluids may be used without departing from the scope of this disclosure.

[0064] The compressor 114 pressurizes the nitrogen gas 118, and this pressure is applied to the hydraulic fluid 106 in the accumulator 116. A valve 120 (such as, a pilot operated control valve) selectively permits and prevents flow of the hydraulic fluid 106 between the accumulator 116 and the primary hydraulic pump 92. The valve 120 is open while the hydraulic pressure source 12 is being used to reciprocate the rod string 18 (thereby allowing the hydraulic fluid 106 to flow back and forth between the accumulator 116 and the hydraulic actuator 14), and is otherwise normally closed. The control system 46 can control operation of the valve 120.

[0065] One or more liquid level sensors 122 on the accumulator 116 detect whether a level of the hydraulic fluid 106 is at upper or lower limits. The hydraulic fluid 106 level typically should not (although at times it may) rise above the upper limit when the piston (52 in FIG. 3) displaces to its lower stroke extent in the cylinder (50 in FIG. 3) and triggers a sensor (70 in FIG. 3), and the hydraulic fluid 106 level typically should not (although at times it may) fall below the lower limit when the piston (52 in FIG. 3) rises to its upper stroke extent and triggers a sensor (70 in FIG. 3).

[0066] A suitable liquid level sensor for use on the accumulator 116 is an electro-optic level switch model no. ELS-1150XP marketed by Gems Sensors & Controls of Plainville, Connecticut USA. However, other types of sensors may be used in keeping with the scope of this disclosure.

[0067] The liquid level sensors 122 are connected to the control system 46, which can increase the hydraulic fluid 106 level by operation of the accessory hydraulic pump 94. Typically, a decrease in hydraulic fluid 106 level is constantly occurring via a lubrication case drain of the

primary hydraulic pump 92 and other seals of the hydraulic pressure source 12 and hydraulic actuator 14, with this hydraulic fluid 106 being directed back to the radiator 98 and hydraulic fluid reservoir 96. Although two liquid level sensors 122 are depicted in FIG. 6, any number of liquid level sensors (or a single continuous sensor) may be used, as may be desired.

[0068] Referring additionally now to FIG. 7, an example process and instrumentation diagram for the hydraulic pressure source 12 is representatively illustrated. Various components of the hydraulic pressure source 12 are indicated in the diagram using the following symbols in the table below labeled "Equipment."

15 Equipment

[0069]

E-1	N ₂ Volume Bottle (110)
20 E-2	N ₂ Volume Bottle (110)
E-3	N ₂ Volume Bottle (110)
E-4	Accumulator (116)
E-5	Hydraulic Fluid Vessel
E-6	Prime Mover (90)
25 E-7	Primary Hydraulic Pump (92)
E-8	Accessory Hydraulic Pump (94)
E-9	Radiator (98)
E-10	Hydraulic Fluid Reservoir (96)
E-11	N ₂ Membrane Filter (112)
30 E-12	Air Particle Filter (1 st stage)
E-13	Air Particle Filter (2 nd stage)
E-14	Air Carbon Filter
E-15	Air Compressor
E-16	N ₂ Booster Compressor (15:1) (114)
35 E-17	Hydraulic Fluid Filter
E-18	Fan
E-19	Air Cooler

40 Valves

[0070]

V-1	Pilot Operated Control Valve V-1 (120)
V-2	Solenoid Valve (for actuation of V-1)
45 V-3	Charge Shunt Valve
V-4	Safety Relief Valve
V-5	Pressure Reducing Valve
V-6	Reverse Flow Check Valve
V-7	Reverse Flow Check Valve

50 Instrumentation

[0071]

55 I-1	Fluid Level Sensor for Hydraulic Fluid Reservoir E-10 (96)
I-2	Temperature Sensor for Hydraulic Fluid Reservoir E-10 (96)

- I-3 N₂ Pressure Sensor
- I-4 Magnetic Field Sensor(s) (70) on Cylinder (50)
- I-5 Control System (46)
- I-6 Accumulator E-4 (116) High Fluid Level Sensor (122)
- I-7 Accumulator E-4 (116) Low Fluid Level Sensor (122)
- I-8 Temperature Sensor on Primary Pump E-7 (92) Outlet
- I-9 Pressure Sensor on Primary Hydraulic Pump E-7 (92) Accumulator Side (to prevent cavitation)
- I-10 Pressure Sensor on Primary Hydraulic Pump E-7 (92) Outlet (to Cylinder 50)

Piping

[0072]

- P-1 Flow to/from Primary Hydraulic Pump E-7 (92) and Cylinder 50
- P-2 Flow from Control Valve V-1 (120) to Primary Pump E-7 (92)
- P-3 Flow from Hydraulic Fluid Vessel E-5 to Control Valve V-1 (120)
- P-4 Flow from Accumulator E-4 (116) to Hydraulic Vessel E-5
- P-5 Flow to/from N₂ Volume Bottle E-3 (110) and Accumulator E-4 (116)
- P-6 Flow to/from N₂ Volume Bottles E-2,3 (110)
- P-7 Flow to/from N₂ Volume Bottles E-1,2 (110)
- P-8 N₂ Flow from Compressor E-16 to N₂ Volume Bottle E-1 (110)
- P-9 Flow from Air Cooler E-19 to Air Particle Filter E-12
- P-10 Flow from Air Compressor E-15 to Air Cooler E-19
- P-11 Flow from Air Particle Filters E-12,13 to Air Carbon Filter E-14
- P-12 Flow from Air Carbon Filter E-14 to N₂ Membrane Filter E-11 (112)
- P-13 Flow from N₂ Membrane Filter E-11 (112) to N₂ Booster Compressor E-16
- P-14 Flow from Accessory Hydraulic Pump E-8 (94) to Valve Manifold V-2/3/4
- P-15 Flow from Valve V-2 to actuate Control Valve V-1 (120)
- P-16 Flow from Primary Hydraulic Pump E-7 (92) case drain and controls to Radiator E-9 (98)
- P-17 Flow from Valve Manifold V-2/3/4 to Radiator E-9 (98)
- P-18 Flow from Cylinder Vent Valve (60) to Reservoir E-10 (96)
- P-19 Flow from Air Compressor E-15 to N₂ Booster Compressor E-16
- P-20 Flow From Radiator E-9 (98) to Hydraulic Fluid Reservoir E-10 (96)

[0073] Note that the scope of this disclosure is not lim-

ited to any specific details of the hydraulic pressure source 12, or any of the components thereof, as described herein or depicted in the drawings. For example, although the nitrogen booster compressor E-16 is listed above as having a 15:1 ratio, other types of compressors may be used if desired.

[0074] In a normal start-up operation, the hydraulic pressure source 12 is powered on, and certain parameters are input to the control system 46 (for example, via a touch screen, keypad, data port, etc.). These parameters can include characteristics of the hydraulic actuator 14 (such as, piston 52 area and maximum stroke length), characteristics of the well (such as, expected minimum and maximum rod string 18 loads, expected well pressure, initial fluid 26 flow rate, etc.), or any other parameters or combination of parameters. Some parameters may already be input to the control system 46 (such as, stored in non-volatile memory), for example, characteristics of the hydraulic pressure source 12 and hydraulic actuator 14 that are not expected to change, or default parameters.

[0075] At this point, the piston rod 54 is already connected to the rod string 18, and the hydraulic actuator 14 is installed on the wellhead 16 above the rod BOP stack 42 and the annular seal housing 44. The control valve 120 is closed, thereby preventing communication between the gas balancing assembly 104 and the primary pump 92.

[0076] The volumes 110 and accumulator 116 may be purged with nitrogen and optionally pre-charged with pressure prior to the start-up operation. Similarly, lines and volumes in the hydraulic pressure source 12 and the hydraulic actuator 14, and lines between the hydraulic pressure source 12 and the hydraulic actuator 14, may be purged with hydraulic fluid 106 prior to (or as part of) the start-up operation.

[0077] The control system 46 determines a minimum volume of the hydraulic fluid 106 that will be needed for reciprocating the piston 52 in the cylinder 50. Alternatively, a default volume of the hydraulic fluid 106 (which volume is appropriate for the actuator 14 characteristics) may be used.

[0078] An appropriate volume of the hydraulic fluid 106 (which volume is preferably greater than the minimum needed) is flowed by operation of the accessory pump 94 from the hydraulic fluid reservoir 96 to fill the hydraulic fluid vessel (E-5 in the Equipment Table) and a lower portion of the accumulator 116. The level sensors 122 are used with the control system 46 to verify that an appropriate level of the hydraulic fluid 106 is present in the accumulator 116.

[0079] The control system 46 determines an appropriate balance pressure that should be applied, based on, for example, the input parameters. Nominally, the balance pressure can be equal to the expected minimum load exerted by the rod string 18 in operation, divided by the piston area of the piston 52. However, as mentioned above, it may in some circumstances be advantageous

to increase or decrease the balance pressure somewhat.

[0080] The air compressor (E-15 in the Equipment Table) is activated to supply a flow of pressurized air through the cooler (E-19 in the Equipment Table) and the air filters (E-12, E-13, E-14 in the Equipment Table) to the membrane filter 112. The membrane filter 112 provides a flow of concentrated nitrogen 118 (e.g., by removal of substantially all oxygen from the air) to the booster compressor 114. Note that pressurized air is also supplied to the booster compressor 114 from the compressor E-15 for operation of the booster compressor.

[0081] The nitrogen 118 flows from the booster compressor 114 into the volumes 110 and an upper portion of the accumulator 116. The booster compressor 114 elevates a pressure of this nitrogen 118 to the desired balance pressure.

[0082] The pressure sensor I-3 monitors the pressure in the gas balancing assembly 104. By virtue of the hydraulic fluid 106 being in contact with the nitrogen 118 in the accumulator 116, the nitrogen pressure is the same as the hydraulic fluid pressure.

[0083] Note that each of the sensors (I-1, I-2, I-3, I-4, I-6, I-7, I-8, I-9, I-10 in the Equipment Table) is connected to the control system 46, so that the control system 46 is capable of monitoring parameters sensed by the sensors. Adjustments to the input parameters can be made by the control system 46 in response to measurements made by the sensors if needed to maintain a desired condition (such as, efficient and economical operation), or to mitigate an undesired condition (such as, pump-off or pump-pound). Such adjustments may be made manually (for example, based on user input), or automatically (for example, based on instructions or programs stored in the control system 46 memory), or a combination of manually and automatically (for example, using a program that initiates automatic control in response to a manual input).

[0084] The piston 52, piston rod 54 and rod string 18 can now be raised by opening the control valve 120 and operating the primary hydraulic pump 92. When the control valve 120 is opened, the balance pressure is applied to the annular chamber 56 below the piston 52 (see FIG. 2). Depending on the selected level of the balance pressure, the balance pressure applied to the annular chamber 56 will typically not cause the piston 52 and attached rod string 18 to displace upward, but some upward displacement of the rod string 18 may be desired in some circumstances.

[0085] The primary hydraulic pump 92 flows pressurized hydraulic fluid 106 from the accumulator 116 and hydraulic fluid vessel E-5 to the annular chamber 56 of the hydraulic actuator 14, and increases the hydraulic fluid pressure therein, thereby causing the piston 52 and attached rod string 18 to rise in the wellbore 16 and operate the downhole pump 20 (see FIG. 1). A hydraulic fluid pressure increase (greater than the balance pressure) needed to displace the piston 52 upwardly to its upper stroke extent is dependent on various factors (such

as, rod string 18 weight, friction in the well and in the hydraulic actuator 14, piston 52 area, well fluid 26 density, depth to the downhole pump 20, etc.).

[0086] Nevertheless, the control system 46 can operate the primary hydraulic pump 92, so that the hydraulic fluid 106 flows into the annular chamber 56 until the piston 52 is displaced to its upper stroke extent. Such displacement of the piston 52 is indicated to the control system 46 by the sensor(s) 70 of the hydraulic actuator 14. Note that the control system 46 can operate the primary hydraulic pump 92 in a manner that avoids an abrupt halt of the piston 52 displacement at the upper stroke extent (e.g., by reducing a flow rate of the hydraulic fluid 106 as the piston 52 approaches the upper stroke extent).

[0087] The piston 52, piston rod 54 and rod string 18 can then be lowered by ceasing operation of the primary pump 92, and allowing the hydraulic fluid 106 to flow from the annular chamber 56 back through the primary hydraulic pump to the hydraulic fluid vessel E-5 and the accumulator 116. Pressure in the annular chamber 56 below the piston 52 will, thus, return to the balance pressure and the load exerted by the rod string 18 will cause the piston 52 and piston rod 54 to descend in the cylinder 50.

[0088] Depending on the level of the balance pressure at this point, the piston 52 may not return to its initial, lowermost position. Instead, the piston 52 typically will descend to a lower stroke extent that avoids pump-pound (e.g., bottoming out of the valve rod bushing 25 against the valve rod guide 23), while providing for efficient and economical operation. As the piston 52 descends in the cylinder 50 and the hydraulic fluid 106 flows from the annular chamber 56 to the hydraulic fluid vessel E-5 and accumulator 116, the control system 46 can operate a variable displacement swash plate (not shown separately) in the primary hydraulic pump 92 in a manner that avoids an abrupt halt of the piston 52 displacement at the lower stroke extent (e.g., by reducing a flow rate of the hydraulic fluid as the piston 52 approaches the lower stroke extent).

[0089] The "reverse" flow of the hydraulic fluid 106 through the primary hydraulic pump 92 could, in some examples, cause the primary hydraulic pump 92 to rotate backward and thereby cause the prime mover 90 (when an electric motor is used) to generate electrical power. Thus, the prime mover 90 can serve as a motor when the hydraulic fluid 106 is pumped to the hydraulic actuator 14, and a generator when the hydraulic fluid is returned to the hydraulic pressure source 12. The generated electrical power may be stored (for example, using batteries, capacitors, etc.) for use by the hydraulic pressure source 12, or the electrical power may be supplied to the local electrical utility (for example, to offset the cost of electrical power supplied to the hydraulic pumping system 10, such as, in situations where the cost is based on demand and/or total usage).

[0090] The above-described actions of raising and lowering the piston 52, piston rod 54 and rod string 18 can

be repeated indefinitely, in order to reciprocate the rod string 18 in the well and operate the downhole pump 20 to flow the well fluid 26 to the surface. However, it should be understood that variations in operation of the hydraulic pressure source 12 and the hydraulic actuator 14 are to be expected as the pumping operation progresses.

[0091] For example, assumptions or estimates may have been made to arrive at certain parameters initially input to the control system 46. After an initial stroking of the hydraulic actuator 14, adjustments may be made automatically or manually (or both) via the control system 46 to account for actual conditions. Such adjustments could include varying the balance pressure, the piston 52 upper or lower stroke extents, the number of piston 52 strokes per minute (spm), etc.

[0092] At any point in the pumping operation, actuation of the hydraulic actuator 14 can be stopped, so that displacement of the piston 52 ceases, and a pressure level in the annular chamber 56 (e.g., sensed using the pressure sensor I-10) needed to support the load exerted by the rod string 18 can be measured. The pressure in the accumulator 116 can then be adjusted, if needed, to provide an appropriate balance.

[0093] The booster compressor 114 can be automatically operated by the control system 46 to increase the balance pressure when appropriate. For example, based on measurements of the pressure applied to the hydraulic actuator 14 over time (sensed by the pressure sensor I-10), it may be determined that efficiency or economy of operation (or work performed, as described more fully below) would be enhanced by increasing the balance pressure. In such circumstances, the control system 46 can operate the booster compressor 114 to increase the pressure on the accumulator 116 until a desired, increased hydraulic balance pressure is achieved (e.g., as sensed by the pressure sensor I-3).

[0094] If a pump-off condition is detected during the pumping operation, a reciprocation speed can be adjusted to avoid this condition. For example, the control system 46 can regulate the hydraulic fluid 106 flow rate (e.g., by varying an operational characteristic of the primary hydraulic pump 92 (such as, by adjusting a swash plate of the primary hydraulic pump 92), varying a rotational speed of the prime mover 90, varying a restriction to flow through the control valve 120, etc.) to decrease a speed of ascent or descent (or both) of the piston 52 in the cylinder 50 if pump-off is detected. Alternatively (or in addition), a stroke length of the piston 52 could be decreased to cause a decrease in the flow rate of the fluid 26 from the well.

[0095] If a pump-pound condition is detected during the pumping operation, the lower stroke extent of the piston 52 can be raised, for example, to avoid contact between the valve rod bushing 25 and the valve rod guide 23 in the downhole pump 20. The lower stroke extent can be raised by decreasing the volume of hydraulic fluid 106 returned to the hydraulic pressure source 12 from the hydraulic actuator 14 (e.g., by the control system 46

beginning to change displacement of a swash plate of the primary hydraulic pump 92 and thereby terminate reverse flow when the piston 52 has descended to the raised lower stroke extent). If the detected pump-pound is due to contacting another component of the downhole pump 20 on an upward stroke, the upper stroke extent of the piston 52 can be lowered by decreasing the volume of hydraulic fluid 106 pumped into the hydraulic actuator 14 (e.g., by the control system 46 ceasing operation of the primary hydraulic pump 92 when the piston 52 has ascended to the lowered upper stroke extent).

[0096] The balance pressure can be increased at any point in the pumping operation by the control system 46 operating the nitrogen concentrator assembly 102 and the booster compressor 114. The balance pressure can be decreased at any point in the operation by discharging an appropriate volume of the nitrogen 118 in the accumulator 116 and/or the nitrogen volumes 110 to the atmosphere.

[0097] The valve manifold V-2/V-3/V-4 can comprise a two position manifold (such as, a National Fluid Power Association (NFPA) D05 manifold marketed by Daman Products Company, Inc. of Mishawaka, Indiana USA) with two position spring return solenoid valves. In one example, a solenoid valve V-2 of the manifold activates V-1 (control valve 120) upon V-2 being energized, and for as long as V-2 remains energized it holds the V-1 control valve (120) open. A sandwich relief valve (such as, an NFPA D05 20 MPa over-pressure safety relief valve marketed by Parker Hannifin Corporation of Cleveland, Ohio USA) can be used with the V-2 valve. Another sandwich relief valve V-4 (such as, adjustable 1 MPa to 7 MPa, set to 2 MPa) of the manifold can function as a charge circuit back-pressure/relief valve placed under a solenoid valve V-3.

[0098] Energizing the V-3 solenoid valve of the manifold closes off a 2 MPa relief flow to the radiator 98 (and back to the hydraulic fluid reservoir 96) to cause pressure from the accessory hydraulic pump 94 to rise to the balance pressure and inject a volume of hydraulic fluid 106 into P-3 (for example, to make up losses from the pressurized gas balancing assembly 104, primary hydraulic pump 92 and cylinder 50 circuit), until the level sensor I-6 indicates that sufficient hydraulic fluid is present in the accumulator 116. When V-3 de-energizes, the accessory hydraulic pump 94 output pressure (in P-14) returns to the 2 MPa relief valve setting. Of course, other settings and other types of valve manifolds may be used, without departing from the scope of this disclosure.

[0099] As mentioned above, certain adjustments may be made if a pump-pound condition is detected. In the FIG. 7 example, a pump-pound condition can be detected by monitoring pressure of the hydraulic fluid 106 as sensed using the sensor I-10.

[0100] The pump-pound condition will be apparent from fluctuations in pressure sensed by the sensor I-10. For example, when the valve rod bushing 25 strikes the valve rod guide 23 of the downhole pump 20, this will

cause an abrupt change in the rod string 18 displacement and the load exerted by the rod string, resulting in a corresponding abrupt change in the piston rod 54 and piston 52 displacement. Such abrupt displacement and load changes will, in turn, produce corresponding pressure changes in the hydraulic fluid 106 flowing from the hydraulic actuator 14 to the hydraulic pressure source 12.

[0101] The control system 46 can be programmed to recognize hydraulic fluid pressure fluctuations that are characteristic of a pump-pound condition. For example, pressure fluctuations having a certain range of frequencies or amplitudes (or both) could be characteristic of a pump-pound condition, and if such frequencies or amplitudes are detected in the sensor I-10 output, the control system 46 can cause certain actions to take place in response. The actions could include displaying an alert, sounding an alarm, recording an event record, transmitting an indication of the pump-pound condition to a remote location, initiating a routine to appropriately raise the lower stroke extent of the piston 52, etc.

[0102] An action that may be automatically implemented by the control system 46 to raise the lower stroke extent of the piston 52 can include incrementally decreasing the volume of hydraulic fluid 106 returned to the hydraulic pressure source 12 from the hydraulic actuator 14 (e.g., by the control system 46 adjusting the swash plate of the primary hydraulic pump 92 to terminate reverse flow when the piston 52 has descended to the raised lower stroke extent), until the pump-pound condition is no longer detected. If pump-pound is detected on an upward stroke of the piston 52, then a similar set of actions can be initiated by the control system 46 to appropriately lower the upper stroke extent of the piston (e.g., by incrementally decreasing the volume of hydraulic fluid 106 pumped into the hydraulic actuator 14 when the piston 52 is stroked upwardly, until the pump-pound condition is no longer detected). As mentioned above, the upper and lower stroke extents could, in some examples, be adjusted by changing positions of the sensors 70 on the cylinder 50.

[0103] Note that pressure fluctuations that are characteristic of a pump-pound condition can change based on a variety of different factors, and the characteristics of pressure fluctuations indicative of a pump-pound condition are not necessarily the same from one well to another. For example, a depth to the downhole pump 20 could affect the amplitude of the pressure fluctuations, and a density of the fluid 26 could affect the frequency of the pressure fluctuations. Therefore, it may be advantageous during the start-up operation to intentionally produce a pump-pound condition, in order to enable detection of pressure fluctuations that are characteristic of the pump-pound condition in that particular well, so that such characteristics can be stored in the control system 46 for use in detecting pump-pound conditions in that particular well. Pressure fluctuations are considered to be a type of vibration of the hydraulic fluid 106.

[0104] However, it should be clearly understood that

the scope of this disclosure is not limited to use of pressure fluctuation measurements to detect a pump-pound condition. Various other types of vibration measurements can be used to indicate a pump-pound condition, and suitable sensors can be included in the system 10 to sense these other types of vibrations. For example, an acoustic sensor, geophone or seismometer (e.g., a velocity sensor, motion sensor or accelerometer) may be used to sense vibrations resulting from a pump-pound condition. The sensor(s) 70 on the actuator 14 could include such sensors, or separate sensors could be used for such purpose if desired.

[0105] As mentioned above, certain adjustments may be made if a pump-off condition is detected. In the FIG. 7 example, a pump-pound condition can be detected by monitoring over time the pressure of the hydraulic fluid 106 as sensed using the sensor I-10, and the displacement of the piston 52 as sensed using the sensor(s) 70.

[0106] In operation, pressure of the hydraulic fluid 106 is directly related to the load or force transmitted between the hydraulic actuator 14 and the rod string 18. Force multiplied by displacement equals work. If a pump-off condition occurs, the total work performed during a reciprocation cycle will decrease due, for example, to gas intake to the pump 20 and/or to less fluid 26 being pumped to the surface.

[0107] Thus, by monitoring the work performed during individual reciprocation cycles over time, the control system 46 can detect whether a pump-off condition is occurring, and can make appropriate adjustments to mitigate the pump-off condition (such as, by decreasing a reciprocation speed of the hydraulic actuator 14, as discussed above). Such adjustments may be made automatically or manually (or both). Other actions (for example, displaying an alert, sounding an alarm, recording an event record, transmitting an indication of the pump-off condition to a remote location, etc.) may be performed by the control system 46 as an alternative to, or in addition to, the adjustments.

[0108] In FIGS. 8A & B, examples of load versus displacement graphs for the system 10 are representatively illustrated. As mentioned above, in operation, load or force transmitted between the hydraulic actuator 14 and the rod string 18 is directly related to hydraulic fluid pressure, and so the graphs could instead be drawn for pressure versus displacement, if desired. Thus, the scope of this disclosure is not limited to any particular technique for determining work performed by the hydraulic actuator 14.

[0109] A reciprocation cycle for the hydraulic actuator 14 is depicted in FIG. 8A without a pump-off condition. In the FIG. 8A graph, it may be observed that the force quickly increases as the hydraulic actuator 14 begins to raise the rod string 18, and then the force substantially levels off as the fluid 26 flows from the well (although in practice the force can decrease somewhat due to fluid 26 inertia effects and as less fluid is lifted near the end of the upward stroke). The force then quickly decreases

as the hydraulic actuator 14 allows the rod string 18 to descend in the well, and then the force substantially levels off until an end of the downward stroke.

[0110] The graph of FIG. 8A has a shape (e.g., generally parallelogram) that is indicative of a reciprocation cycle with no pump-off condition. In actual practice, the idealized parallelogram shape of the FIG. 8A graph will not be exactly produced, but the control system 46 can be programmed to recognize shapes that are indicative of reciprocation cycles with no pump-off condition.

[0111] An area A_1 of the FIG. 8A graph is representative of the total work performed during this reciprocation cycle (e.g., including a summation of the work performed during the upward and downward strokes). The area A_1 can be readily calculated by the control system 46 for comparison to other areas of reciprocation cycles, either prior to or after the FIG. 8A reciprocation cycle.

[0112] By comparing the total work performed in different reciprocation cycles, the control system 46 can determine whether and how the work performed has changed. If the total work performed has changed, the control system 46 can make appropriate adjustments to certain parameters, in order to mitigate any undesired conditions, or to enhance any desired conditions.

[0113] In FIG. 8B, the force versus displacement graph for another reciprocation cycle is depicted, in which a pump-off condition is occurring. Note that an area A_2 of the FIG. 8B graph is less than the area A_1 of the FIG. 8A graph. This indicates that less total work is performed in the FIG. 8B reciprocation cycle, as compared to the FIG. 8A reciprocation cycle.

[0114] If the FIG. 8B reciprocation cycle is after the FIG. 8A reciprocation cycle, the control system 46 can recognize that less total work is being performed over time, and can make appropriate adjustments (such as, by reducing the reciprocation speed). Such adjustments can be made incrementally, with repeated comparisons of total work performed over time, so that the control system 46 can verify whether the adjustments are accomplishing intended results (e.g., increased total work performed over time, due to reduced pump-off).

[0115] If the FIG. 8A reciprocation cycle is after the FIG. 8B reciprocation cycle, the control system 46 can recognize that more work is being performed over time and that, if incremental adjustments are being made, those incremental adjustments should continue. However, the control system 46 can discontinue the adjustments, for example, if other objectives (such as, operational efficiency, economy, etc.) would be reduced if the adjustments continue.

[0116] The FIG. 8B graph has a shape that is not indicative of a reciprocation cycle in which a pump-off condition is not occurring. Stated differently, the shape of the FIG. 8B graph (for example, with a rounded upward slope, reduced maximum force on the upward stroke and one or more reductions in force during the upward stroke) is indicative of a pump-off condition. The control system 46 can be programmed to recognize such shapes, so

that adjustments can be made to mitigate the pump-off condition.

[0117] Similar to the procedure described above for situations (where the control system 46 recognizes a substantial change in total work performed), the control system can incrementally decrease the reciprocation speed if a pump-off condition is detected, until the shape of the force (or pressure) versus displacement graph for a reciprocation cycle does not indicate pump-off. If force (or pressure) versus displacement graphs initially do not indicate a pump-off condition, the control system 46 can incrementally increase the reciprocation speed (to thereby increase a rate of production), until the shape of the graph for a reciprocation cycle does begin to indicate pump-off, at which point the control system can incrementally decrease the reciprocation speed until the shape of the graph does not indicate pump-off. In this manner, production rate can be maximized, without any sustained pump-off condition.

[0118] It will be readily appreciated that the graphs shown in FIGS. 8A and 8B are visual illustrations of measured force or pressure with respect to measured displacement of the piston 52 and rod string 18. If automatic adjustment of any of the hydraulic actuator 14 operating parameters, e.g., reciprocation rate, maximum stroke extent, etc. are implemented by the control system 46, actual graphs may not be constructed or displayed. The control system 46 may detect the numerical or other equivalent of the "shape" of a graph by implementing suitable detection and control processes therein in response to measurements from any one or more of the various sensors described herein.

[0119] Referring additionally now to FIG. 9, another example of the hydraulic actuator 14 is representatively illustrated. In this example, a position of the piston 52 (and the rod string 18 connected thereto) can be continuously sensed, to thereby provide for more precise control over reciprocation of the piston 52 and rod string 18. More precise reciprocation control can provide for enhanced pumping efficiency, mitigation of pump-off and pump-pound conditions, and prevention of gas-lock.

[0120] In the FIG. 9 example, a position sensor 130 is used to continuously detect the position of the piston 52. For example, the position sensor 130 can comprise a linear transducer (or a linear variable displacement transducer). The position sensor 130 in this example can be a Hall effect sensor capable of continuously sensing the presence and position of the magnet 72 on the piston 52 as it displaces to and between its upper and lower stroke extents.

[0121] As used herein, the term "continuous" is used to refer to a substantially uninterrupted sensing of position by the sensor 130. For example, when used to continuously detect the position of the piston 52, the sensor 130 can detect the piston's position during all portions of its reciprocating motion, and not just at certain discrete points (such as, at the upper and lower stroke extents). However, a continuous position sensor may have a par-

ticular resolution (e.g., .001-0.1 mm) at which it can detect the position of a member. Accordingly, the term "continuous" does not require an infinitely small resolution.

[0122] A suitable position sensor for use as the sensor 130 in the system 10 is available from Rota Engineering Ltd. of Manchester, United Kingdom. Other suitable position sensors are available from Hans Turck GmbH & Co. KG of Germany, and from Balluff GmbH of Germany. However, the scope of this disclosure is not limited to use of any particular sensor with the system 10.

[0123] As depicted in FIG. 9, the sensor 130 is attached externally to the cylinder 50, so that the sensor 130 extends longitudinally along the cylinder 50. In other examples, the sensor 130 could be otherwise located (such as, in the wall 74 of the cylinder 50, in the piston rod 54, etc.), or could be otherwise oriented (such as, extending helically on or in the cylinder 50, etc.). Thus, the scope of this disclosure is not limited to any particular location or orientation of the sensor 130.

[0124] An output of the sensor 130 can be communicated to the control system 46. In this manner, the control system 46 can be provided with an accurate measurement of the piston 52 position at any point in the piston's reciprocation, thereby dispensing with any need to perform calculations based on discrete detections of position (as with the sensors 70 of FIG. 3), detections/calculations of hydraulic fluid 106 displacement, etc. It will be appreciated by those skilled in the art that actual continuous position detection can be more precise than such calculations of position, since various factors (including known and unknown factors, such as, temperature, fluid compressibility, fluid leakage, etc.) can affect the calculations.

[0125] The control system 46, provided with accurate continuous measurement of the piston's 52 position, can more precisely control operation of the hydraulic pressure source 12 (see FIG. 1) to achieve various objectives. For example, the control system 46 can operate the hydraulic pressure source 12 in a manner that prevents or mitigates gas-lock, optimizes work output, increases efficiency, reduces peak or average electrical power consumption, etc. However, note that the scope of this disclosure is not limited to accomplishment of any particular objective by communication of continuous position measurements to the control system 46.

[0126] Note that the entire rod string 18 does not displace as an infinitely rigid member. Instead, the rod string 18 has some elasticity and there are dampening effects present (such as, friction between the rod string 18 and the tubing string 30, etc.), so that the reciprocating displacement of a lower end of the rod string at the downhole pump 20 is not the same as the reciprocating displacement of the upper end of the rod string at the surface.

[0127] Accordingly, a wave equation in the rod string 18 can be solved, so that reciprocating displacement (or desired changes therein) at the surface corresponds to reciprocating displacement (or desired changes therein) at the downhole pump 20. The Everitt-Jennings algorithm may be used to solve the wave equation (see Everitt,

T.A. and Jennings, J.W., An Improved Finite-Difference Calculation of Downhole Dynamometer Cards for Sucker-Rod Pumps, SPE 18189, February 1992). The full wave equation solution determines force versus position of the rod string 18 at the downhole pump 20, but intermediate calculations can be used to derive characteristics such as stroke extents, stroke distance, velocity, acceleration, etc.

[0128] Thus, working "backward" from a desired reciprocating displacement (with certain characteristics, such as, desired stroke extents, stroke length, etc.) at the downhole pump 20, solution of the wave equation produces a corresponding desired reciprocating displacement (with certain characteristics) at the surface (e.g., at a reciprocating member of the actuator 14, or an upper end of the rod string 18). As another example, solution of the wave equation in the rod string 18 may be used to determine a change in work performed during reciprocation cycles of the hydraulic actuator 14 and a change in detected force versus displacement in different reciprocation cycles of the hydraulic actuator.

[0129] Referring additionally now to FIG. 10, an example of a technique whereby the control system 46 can operate the hydraulic pressure source 12 to prevent or mitigate a gas-lock condition is representatively illustrated. This technique can be enhanced using precise control of the hydraulic pressure source 12 by the control system 46 due to the continuous position measurements described above in relation to FIG. 9 and solution of the wave equation in the rod string 18, but it should be understood that such continuous position measurements and solution of the wave equation are not necessarily required.

[0130] As mentioned above, a gas-lock condition can occur when a sufficient quantity of gas has accumulated in a downhole pump, so that the downhole pump is rendered inoperative to flow liquids to the surface. Such an accumulation of gas in the downhole pump can be caused by a pump-off condition, or by the gas coming out of solution and accumulating over time as fluid is flowed through the downhole pump (for example, gas can come out of solution when pressure is reduced in the downhole pump to draw the fluid into the pump).

[0131] In highly deviated wells, and particularly horizontal wells, where the pump is placed at a point above a final build radius, there can be a high probability that slug flow will ensue. Slugging occurs because the gas breaks out of solution and flows independently from the liquid in the horizontal section. As the liquid is drawn into the pump a slug of gas may accompany the liquid. The well is not technically "pumped-off," but there is sufficient gas present to displace the liquid from entering the pump barrel.

[0132] A result of a gas-lock condition is that the compressibility of the fluid in the downhole pump prevents a pump chamber from emptying. When the fluid in the pump chamber is compressible (for example, due to gas in solution in the fluid, or due to free gas in the chamber),

a percentage of pump stroke that is useful for displacing the fluid may be reduced to such an extent that little or no fluid displacement occurs through the pump. The fluid in the pump chamber is compressed, but this compression does not increase pressure in the fluid sufficiently to discharge the fluid from the pump. Since the fluid in the pump is not discharged, no additional fluid can be drawn into the chamber.

[0133] In the FIG. 10 example, the traveling valve 24 reciprocates in a pump barrel 132 relative to the standing valve 22. Thus, a variable volume pump chamber 134 is formed in the pump barrel 132 between the standing and traveling valves 22, 24. A volume of the chamber 134 alternately increases and decreases as a distance D between the standing and traveling valves 22, 24 also alternately increases and decreases.

[0134] The fluid 26 in the tubing string 30 above the traveling valve 24 exerts hydrostatic pressure on the traveling valve 24. Thus, in order to discharge fluid 26 from the chamber 134, the pressure of the fluid 26 must be increased to greater than the hydrostatic pressure in the tubing string 30.

[0135] When the traveling valve 24 displaces downward (thereby decreasing the distance D), the volume of the chamber 134 decreases relative to its volume when the traveling valve 24 is at its upper stroke extent. A ratio of maximum chamber 134 volume to minimum chamber 134 volume affects whether pressure in the chamber 134 will be increased sufficiently to overcome the hydrostatic pressure exerted on the traveling valve 24, so that the fluid 26 in the chamber 134 will be discharged into the tubing string 30.

[0136] It will be appreciated by those skilled in the art that, if the fluid 26 in the chamber 134 is compressible, a larger ratio of maximum to minimum chamber 134 volume will be required to sufficiently increase pressure in the chamber. Thus, if enough gas accumulates in the chamber 134, or if the fluid 26 in the chamber 134 has enough gas in solution therein, pressure in the chamber 134 may not be sufficiently increased to discharge the fluid 26 from the chamber 134 when the traveling valve 24 displaces to its lower stroke extent.

[0137] In the system 10, however, displacement of the traveling valve 24 can be more precisely controlled, so that a gas-lock condition can be prevented, or can be mitigated if it has already occurred. More specifically, the distance D between the traveling valve 24 and the standing valve 22 at the lower stroke extent of the traveling valve 24 can be controllably minimized to thereby increase the ratio of maximum to minimum chamber 134 volume. In addition, velocities of the traveling valve 24 during its upward and downward strokes (as viewed in FIG. 10) can be independently controlled to enhance filling and discharging of the chamber 134.

[0138] A technique for minimizing the distance D between the standing and traveling valves 22, 24 at the lower stroke extent of the traveling valve 24 can be performed after the downhole pump 20 and tubing string 30

have been deployed into the wellbore 28, and the hydraulic pressure source 12, hydraulic actuator 14 and control system 46 have been installed (see FIGS. 1-7 and 9) and are operational. The technique may be performed as part of a start-up or initialization process, and/or at a subsequent time(s) (such as, after the system 10 has been operated for some time, periodically during operation of the system 10, etc.).

[0139] In the technique, the lower stroke extent of the traveling valve 24 is incrementally lowered (thereby incrementally decreasing the distance D at the lower stroke extent of the traveling valve 24) by allowing the piston 52 (see FIGS. 2 & 9) to descend incrementally farther in the cylinder 50 over multiple reciprocation cycles. For example, the lower stroke extents of the piston 52 and the traveling valve 24 may be incrementally lowered in each of multiple successive reciprocation cycles.

[0140] An amount of each incremental lowering can be selected as appropriate for a particular configuration of the system 10 (such as, depending on the downhole pump 20 configuration, a length of the rod string 18, an amount of friction, whether the sensors 70 or sensor 130 (see FIGS. 3 & 9) are used, etc.). For example, the incremental lowering amount could be on the order of 0.1-0.5 cm.

[0141] In this example, the incremental lowering continues as the piston 52, rod string 18 and traveling valve 24 reciprocate, until a pump-pound condition is detected. The pump-pound condition may be detected, for example, by sensing a vibration characteristic of the pump-pound condition, or by detection of a decrease in work performed by the system 10, as described above (for example, by solving the wave equation in the rod string 18 to produce a "downhole card" indicating load versus position (the integral of which is work) at the downhole pump 20). The pump-pound condition may be due to the rod bushing 25 striking the valve rod guide 23 as the rod string 28 descends.

[0142] When the pump-pound condition is detected, the lower stroke extents of the piston 52 and the traveling valve 24 are raised sufficiently to alleviate the pump-pound condition. For example, the lower stroke extents may be raised by a predetermined amount (such as, 0.5-1.0 cm), or the lower stroke extents may be raised incrementally until the pump-pound condition is no longer detected.

[0143] Although the technique described above can be accomplished by the control system 46 controlling operation of the hydraulic pressure source 12 (see FIG. 1) with indications of the piston 52 positions being provided by the sensors 70 (see FIG. 3), enhanced precision of the operation can be provided by the continuous position sensing of the position sensor 130 (see FIG. 9).

[0144] As mentioned above, velocities of the traveling valve 24 during its upward and downward strokes (as viewed in FIG. 10) can be independently controlled to enhance filling and discharging of the chamber 134. For example, the upward stroke velocity of the traveling valve

24 can be decreased relative to the downward stroke velocity, so that the chamber 134 volume increases at a reduced rate, thereby allowing the chamber 134 to fill more completely and reducing or preventing gas from coming out of solution in the chamber 134.

[0145] When it is desired to change a characteristic (such as, the upper or lower stroke extent, the stroke distance, the upward or downward velocity, etc.) of the reciprocating displacement of the rod string 18 at the downhole pump 20, the wave equation in the rod string 18 may be solved (e.g., using the Everitt-Jennings algorithm or another suitable algorithm), in order to determine how the reciprocating displacement at the surface should be changed to produce an appropriate change at the downhole pump 20. Using the output of the continuous position sensor 130, the control system 46 can verify that the appropriate change has been made, or can modify operation of the pressure source 12 and actuator 14 as appropriate to achieve the desired change.

[0146] Note that the operation of the downhole pump 20 as described herein refers to displacement of the traveling valve 24, which varies a volume of the chamber 134 in the pump barrel 132. However, other downhole pump configurations can be used in keeping with the scope of this disclosure. For example, in some downhole pump configurations, a piston (without a valve therein) could be used instead of the traveling valve 24, or another means could be used to vary a volume of a chamber in the pump. Thus, the scope of this disclosure is not limited to any of the details of the downhole pump 20 or its operation as described herein or depicted in the drawings.

[0147] It may now be fully appreciated that the above description provides significant advancements to the art of artificial lifting for subterranean wells. In various examples described above, pumping of a fluid from a well can be made more efficient, convenient, economical and productive utilizing the hydraulic pumping system 10 and associated methods.

[0148] The above disclosure provides to the art a hydraulic pumping system 10 for use with a subterranean well. In one example, the system 10 can include a hydraulic actuator 14 including a piston 52 that displaces in response to pressure in the actuator 14, a magnet 72 that displaces with the piston 52, and at least one sensor 130 that continuously detects a position of the magnet 72 as the magnet displaces with the piston 52. A ferromagnetic wall 74 of the hydraulic actuator 14 is positioned between the magnet 72 and the sensor 130.

[0149] The sensor 130 may comprise a linear transducer. The sensor 130 may be a Hall effect sensor.

[0150] Displacement of the piston 52 can be automatically varied in response to solution of a wave equation in a rod string 18 connected to the piston 52. The wave equation solution may determine force versus position of the rod string 18 at a downhole pump 20 connected to the rod string.

[0151] A lower stroke extent of the piston 52 may be incrementally lowered over multiple reciprocation cycles,

until a pump-pound condition is detected. The lower stroke extent of the piston 52 may be raised in response to detection of the pump-pound condition.

[0152] The ferromagnetic wall 74 of the hydraulic actuator 14 can have a thickness of at least approximately 1.25 cm.

[0153] The system 10 may include a hydraulic pump 92 connected between the hydraulic actuator 14 and an accumulator 116, with the accumulator receiving nitrogen gas from a nitrogen concentrator assembly 102 while a hydraulic fluid 106 flows between the hydraulic pump 92 and the hydraulic actuator 14.

[0154] The system 10 may include a hydraulic pump 92 connected between the hydraulic actuator 14 and an accumulator 116, with a hydraulic fluid 106 in contact with a pressurized gas 118 in the accumulator 116. Pressure in the accumulator 116 may be automatically regulated in response to measurements of pressure applied to the hydraulic actuator 14.

[0155] A reciprocation speed of the piston 52 may be automatically varied in response to at least one of: a) a change in work performed during reciprocation cycles of the system 10 and b) a change in detected force versus displacement in different reciprocation cycles of the system 10.

[0156] An extent of reciprocation displacement of the piston 52 may be automatically varied in response to a measured vibration.

[0157] A hydraulic pumping method for use with a subterranean well having a rod string 18 connected to a downhole pump 20 is also provided to the art by the above disclosure. In one example, the method can include reciprocating the rod string 18 in response to pressure in a hydraulic actuator 14 connected to the rod string 18; incrementally lowering a lower stroke extent of the rod string 18 reciprocation over multiple reciprocation cycles of the rod string; and automatically varying at least one of: a) the lower stroke extent, and b) an upper stroke extent of the rod string 18 reciprocation, in response to a measured vibration.

[0158] The method may include solving a wave equation in the rod string 18. The step of solving the wave equation in the rod string 18 can comprise determining force versus displacement in the rod string 18 at the downhole pump 20.

[0159] The incrementally lowering step may be performed until a pump-pound condition is detected. The pump-pound condition may be indicated by the measured vibration.

[0160] The automatically varying step can comprise raising the lower stroke extent of the rod string 18 reciprocation in response to detection of the pump-pound condition.

[0161] The method can include continuously sensing a position of the rod string 18 as the rod string reciprocates.

[0162] The vibration may be sensed by at least one of a pressure sensor, an acoustic sensor, a geophone and

a seismometer.

[0163] The step of automatically varying the extent of reciprocation displacement can comprise raising the lower stroke extent of the rod string 18 reciprocation.

[0164] The method can include automatically varying a reciprocation speed of the rod string 18 in response to a change in work performed during reciprocation cycles of the hydraulic actuator 14 over time, or in response to a change in shapes of force versus displacement graphs for reciprocation cycles of the hydraulic actuator 14 over time.

[0165] The method may include connecting a hydraulic pump 92 between the hydraulic actuator 14 and an accumulator 116, with the accumulator 116 receiving nitrogen gas 118 from a nitrogen concentrator assembly 102 while a hydraulic fluid 106 flows between the hydraulic pump 92 and the hydraulic actuator 14. The hydraulic fluid 106 may be contact with a pressurized gas 118 in the accumulator 116. The method can comprise automatically regulating pressure in the accumulator 116 in response to measurements of pressure applied to the hydraulic actuator 14.

[0166] Another hydraulic pumping method for use with a subterranean well having a rod string 18 connected to a downhole pump 20 is described above. In one example, the method can comprise: reciprocating the rod string 18 in response to pressure in a hydraulic actuator 14 connected to the rod string; solving a wave equation in the rod string 18; and automatically varying a reciprocation speed of the rod string 18 in response to at least one of the group consisting of: a) a change in work performed during reciprocation cycles of the hydraulic actuator 14 and b) a change in detected force versus displacement in different reciprocation cycles of the hydraulic actuator 14.

[0167] Although various examples have been described above, with each example having certain features, it should be understood that it is not necessary for a particular feature of one example to be used exclusively with that example. Instead, any of the features described above and/or depicted in the drawings can be combined with any of the examples, in addition to or in substitution for any of the other features of those examples. One example's features are not mutually exclusive to another example's features. Instead, the scope of this disclosure encompasses any combination of any of the features.

[0168] Although each example described above includes a certain combination of features, it should be understood that it is not necessary for all features of an example to be used. Instead, any of the features described above can be used, without any other particular feature or features also being used.

[0169] It should be understood that the various embodiments described herein may be utilized in various orientations, such as inclined, inverted, horizontal, vertical, etc., and in various configurations, without departing from the principles of this disclosure. The embodiments are described merely as examples of useful applications of

the principles of the disclosure, which is not limited to any specific details of these embodiments.

[0170] In the above description of the representative examples, directional terms (such as "above," "below," "upper," "lower," etc.) are used for convenience in referring to the accompanying drawings. However, it should be clearly understood that the scope of this disclosure is not limited to any particular directions described herein.

[0171] The terms "including," "includes," "comprising," "comprises," and similar terms are used in a non-limiting sense in this specification. For example, if a system, method, apparatus, device, etc., is described as "including" a certain feature or element, the system, method, apparatus, device, etc., can include that feature or element, and can also include other features or elements. Similarly, the term "comprises" is considered to mean "comprises, but is not limited to."

[0172] Of course, a person skilled in the art would, upon a careful consideration of the above description of representative embodiments of the disclosure, readily appreciate that many modifications, additions, substitutions, deletions, and other changes may be made to the specific embodiments, and such changes are contemplated by the principles of this disclosure. For example, structures disclosed as being separately formed can, in other examples, be integrally formed and *vice versa*. Accordingly, the foregoing detailed description is to be clearly understood as being given by way of illustration and example only, the spirit and scope of the invention being limited solely by the appended claims and their equivalents. Each feature disclosed or illustrated in the present specification may be incorporated in the invention, whether alone or in any appropriate combination with any other feature disclosed or illustrated herein.

Claims

1. A hydraulic pumping system for use with a subterranean well, the system comprising:
 - a hydraulic actuator including a piston that displaces in response to pressure in the actuator, a magnet that displaces with the piston, and at least one sensor that continuously detects a position of the magnet as the magnet displaces with the piston, wherein a ferromagnetic wall of the hydraulic actuator is positioned between the magnet and the sensor.
2. The system of claim 1, wherein the sensor comprises a linear transducer.
3. The system of claim 1, wherein the sensor is a Hall effect sensor.
4. The system of claim 1, wherein displacement of the

piston is automatically varied in response to solution of a wave equation in a rod string connected to the piston.

5. The system of claim 1, wherein a lower stroke extent of the piston is incrementally lowered over multiple reciprocation cycles, until a pump-pound condition is detected. 5
6. The system of claim 1, wherein the ferromagnetic wall of the hydraulic actuator has a thickness of at least approximately 1.25 cm. 10
7. The system of claim 1, further comprising a hydraulic pump connected between the hydraulic actuator and an accumulator, and wherein the accumulator receives nitrogen gas from a nitrogen concentrator assembly while a hydraulic fluid flows between the hydraulic pump and the hydraulic actuator. 15
8. The system of claim 1, further comprising a hydraulic pump connected between the hydraulic actuator and an accumulator, and wherein a hydraulic fluid is in contact with a pressurized gas in the accumulator. 20
9. The system of claim 1, further comprising a hydraulic pump connected between the hydraulic actuator and an accumulator, and wherein pressure in the accumulator is automatically regulated in response to measurements of pressure applied to the hydraulic actuator. 25
10. The system of claim 1, wherein a reciprocation speed of the piston is automatically varied in response to at least one of: a) a change in work performed during reciprocation cycles of the system and b) a change in detected force versus displacement in different reciprocation cycles of the system. 30
11. The system of claim 1, wherein an extent of reciprocation displacement of the piston is automatically varied in response to a measured vibration. 35
12. A hydraulic pumping method for use with a subterranean well having a rod string connected to a down-hole pump, the method comprising: 40

reciprocating the rod string in response to pressure in a hydraulic actuator connected to the rod string; 50

incrementally lowering a lower stroke extent of the rod string reciprocation over multiple reciprocation cycles of the rod string; and automatically varying at least one of: a) the lower stroke extent, and b) an upper stroke extent of the rod string reciprocation, in response to a measured vibration. 55

13. The method of claim 12, further comprising solving a wave equation in the rod string.
14. The method of claim 12, wherein the incrementally lowering is performed until a pump-pound condition is detected.
15. The method of claim 12, further comprising continuously sensing a position of the rod string as the rod string reciprocates.
16. The method of claim 12, wherein the vibration is sensed by at least one of the group consisting of a pressure sensor, an acoustic sensor, a geophone and a seismometer.
17. The method of claim 12, wherein automatically varying the extent of reciprocation displacement comprises raising the lower stroke extent of the rod string reciprocation.
18. The method of claim 12, further comprising automatically varying a reciprocation speed of the rod string in response to a change in work performed during reciprocation cycles of the hydraulic actuator over time.
19. The method of claim 12, further comprising automatically varying a reciprocation speed of the rod string in response to a change in shapes of force versus displacement graphs for reciprocation cycles of the hydraulic actuator over time.
20. The method of claim 12, further comprising connecting a hydraulic pump between the hydraulic actuator and an accumulator, and the accumulator receiving nitrogen gas from a nitrogen concentrator assembly while a hydraulic fluid flows between the hydraulic pump and the hydraulic actuator.
21. The method of claim 12, further comprising connecting a hydraulic pump between the hydraulic actuator and an accumulator, and wherein a hydraulic fluid is in contact with a pressurized gas in the accumulator.
22. The method of claim 12, wherein a hydraulic pump is connected between the hydraulic actuator and an accumulator, and further comprising automatically regulating pressure in the accumulator in response to measurements of pressure applied to the hydraulic actuator.
23. A hydraulic pumping method for use with a subterranean well having a rod string connected to a down-hole pump, the method comprising:

reciprocating the rod string in response to pressure in a hydraulic actuator connected to the rod

string;

solving a wave equation in the rod string; and automatically varying a reciprocation speed of the rod string in response to at least one of the group consisting of: a) a change in work performed during reciprocation cycles of the hydraulic actuator and b) a change in detected force versus displacement in different reciprocation cycles of the hydraulic actuator.

5

10

24. The method of claim 23, wherein the reciprocation speed is decreased in response to a measured decrease in the work performed during the reciprocation cycles.

15

25. The method of claim 23, further comprising automatically varying an extent of reciprocation displacement of the rod string in response to a measured vibration.

20

26. The method of claim 23, further comprising connecting a hydraulic pump between the hydraulic actuator and an accumulator, and the accumulator receiving nitrogen gas from a nitrogen concentrator assembly while a hydraulic fluid flows between the hydraulic pump and the hydraulic actuator.

25

27. The method of claim 23, further comprising connecting a hydraulic pump between the hydraulic actuator and an accumulator, and wherein a hydraulic fluid is in contact with a pressurized gas in the accumulator.

30

28. The method of claim 23, wherein a hydraulic pump is connected between the hydraulic actuator and an accumulator, and further comprising automatically regulating pressure in the accumulator in response to measurements of pressure applied to the hydraulic actuator.

35

40

45

50

55

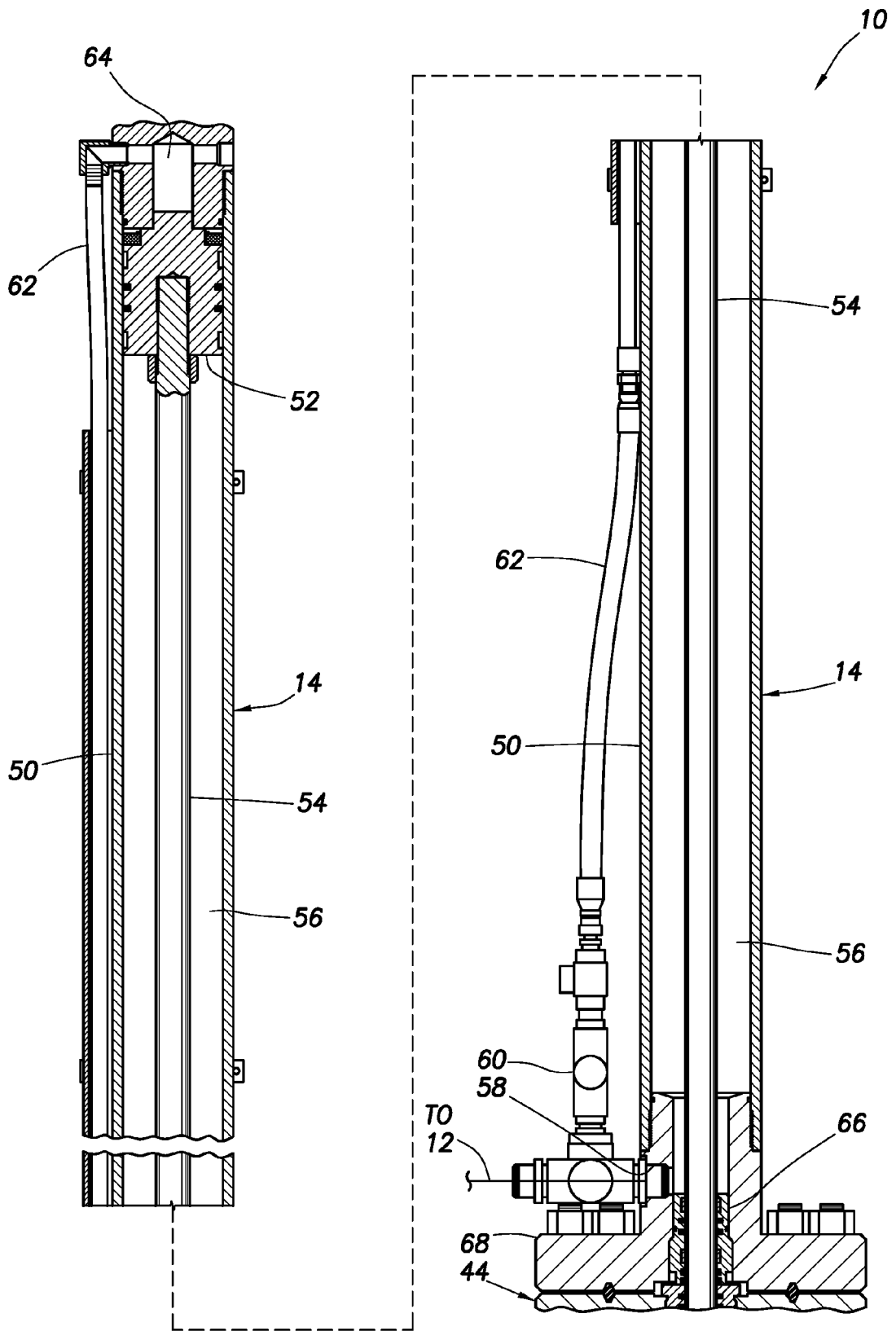

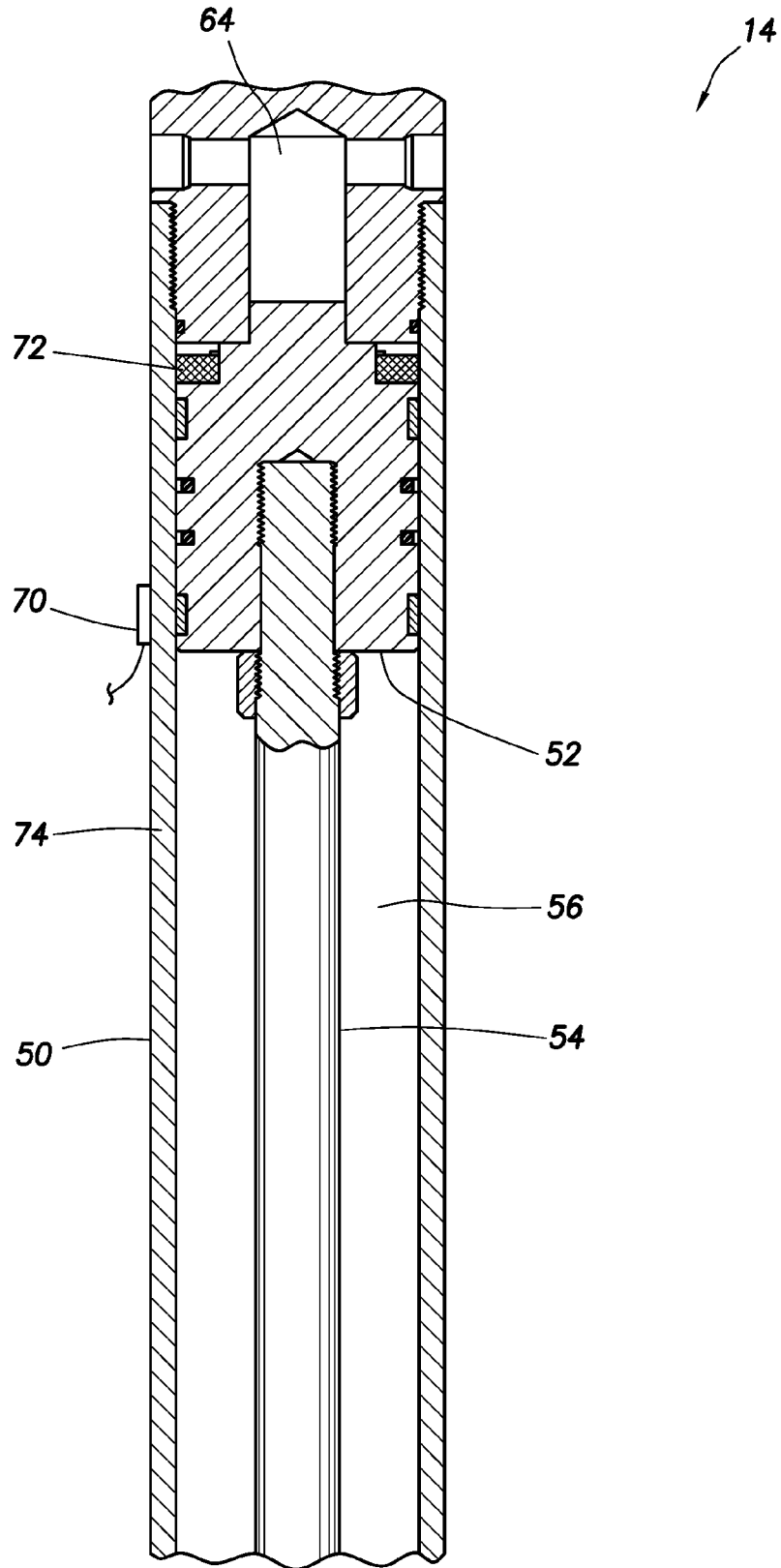
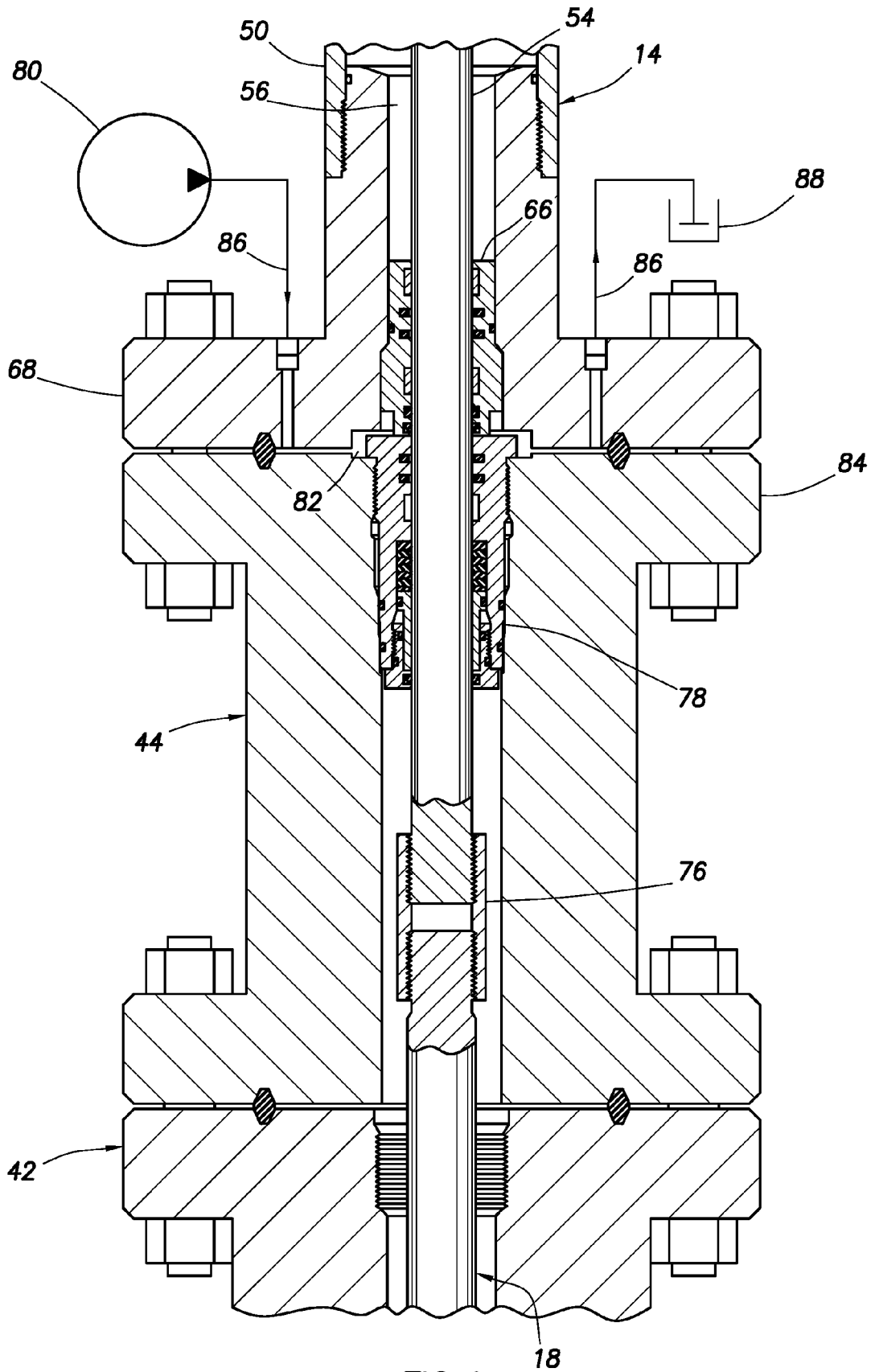

FIG.3



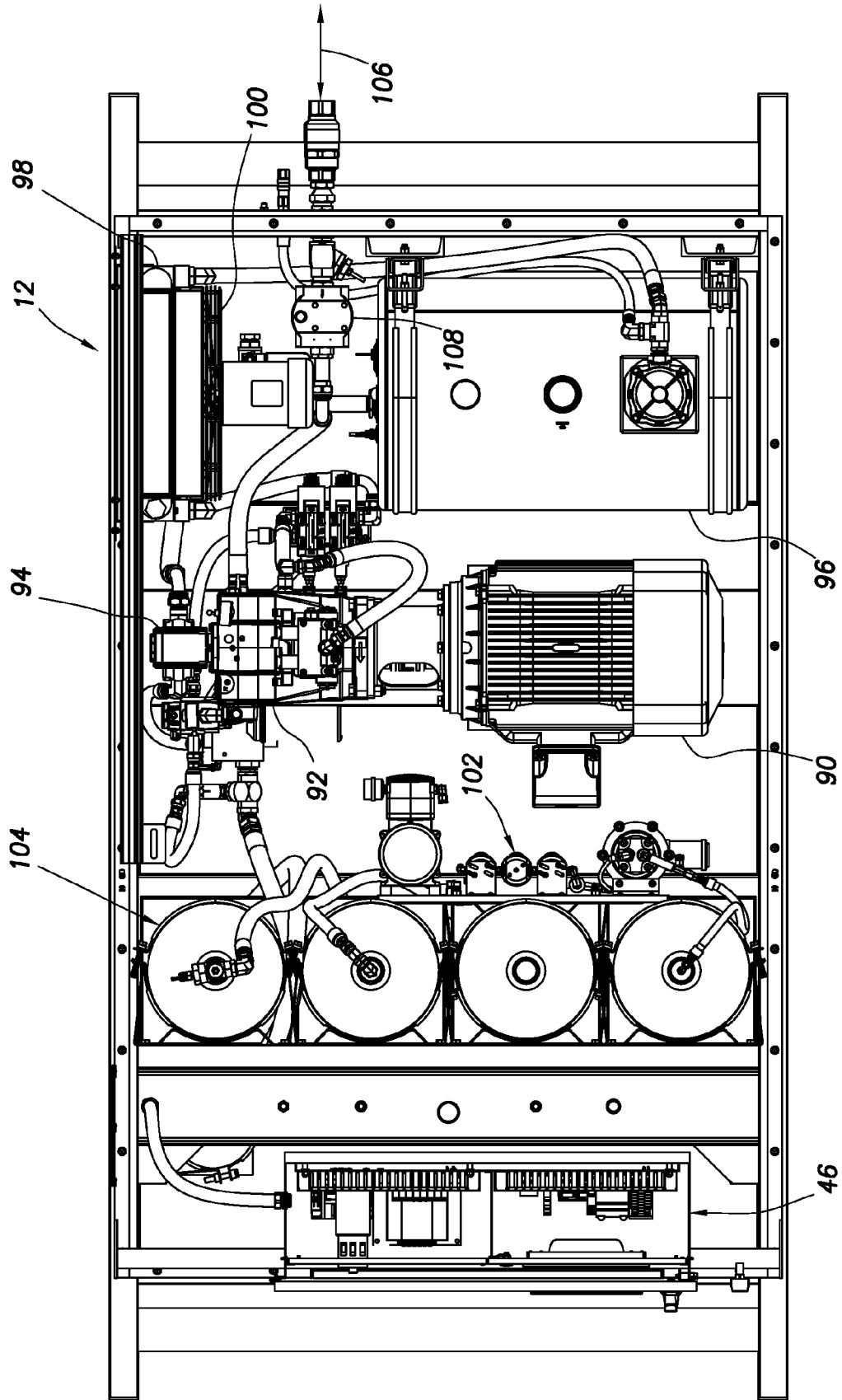

FIG.5

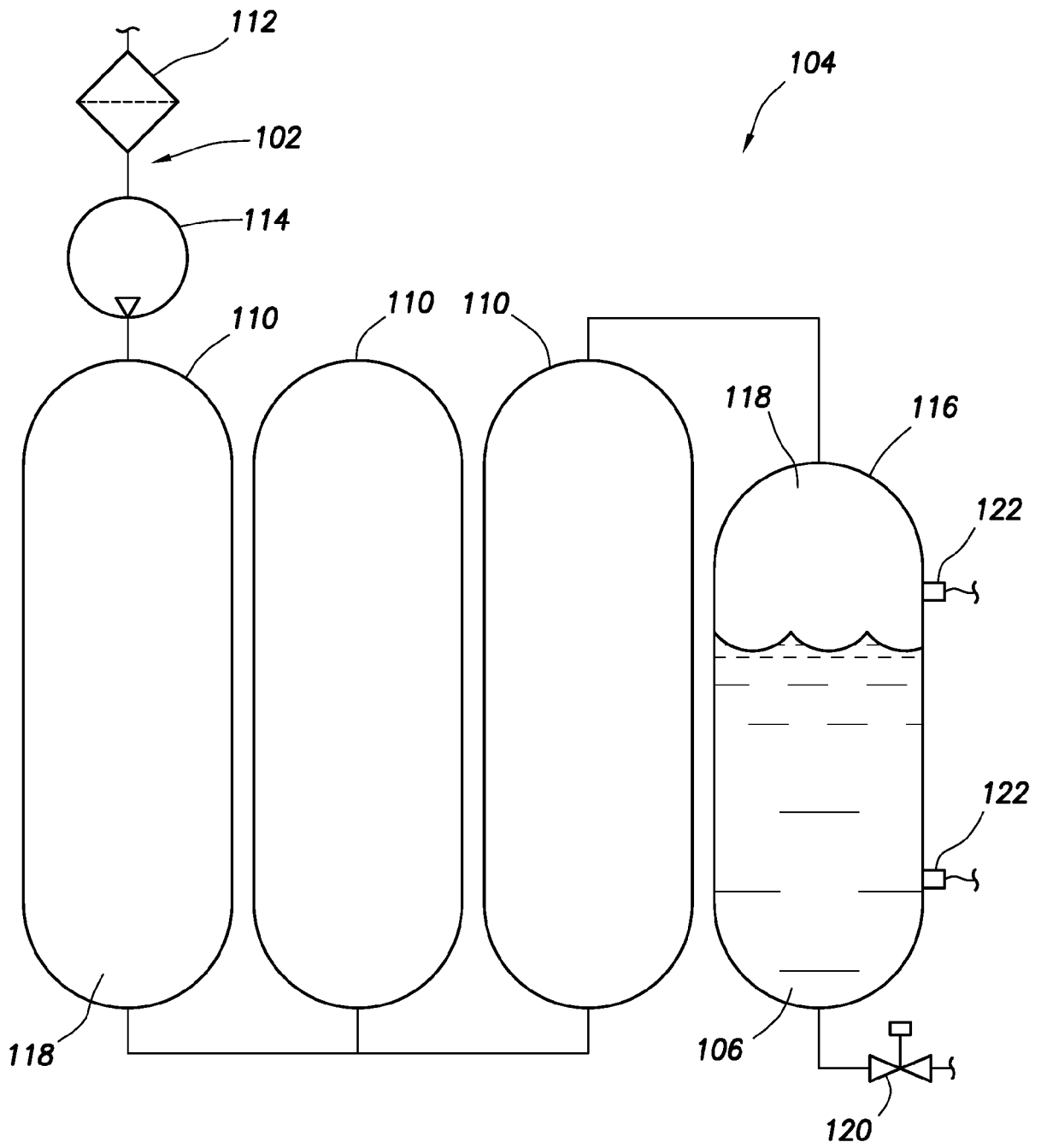

FIG.6

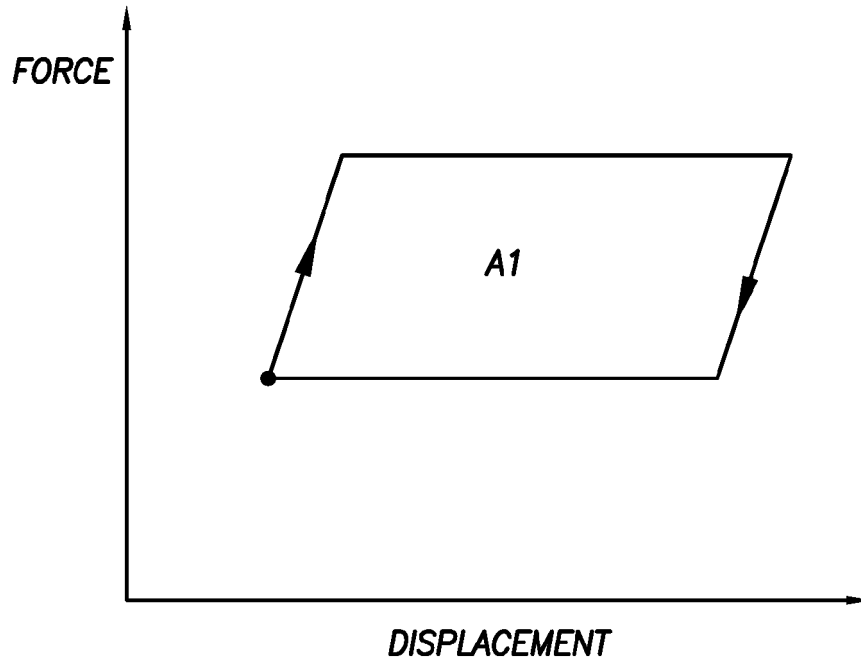
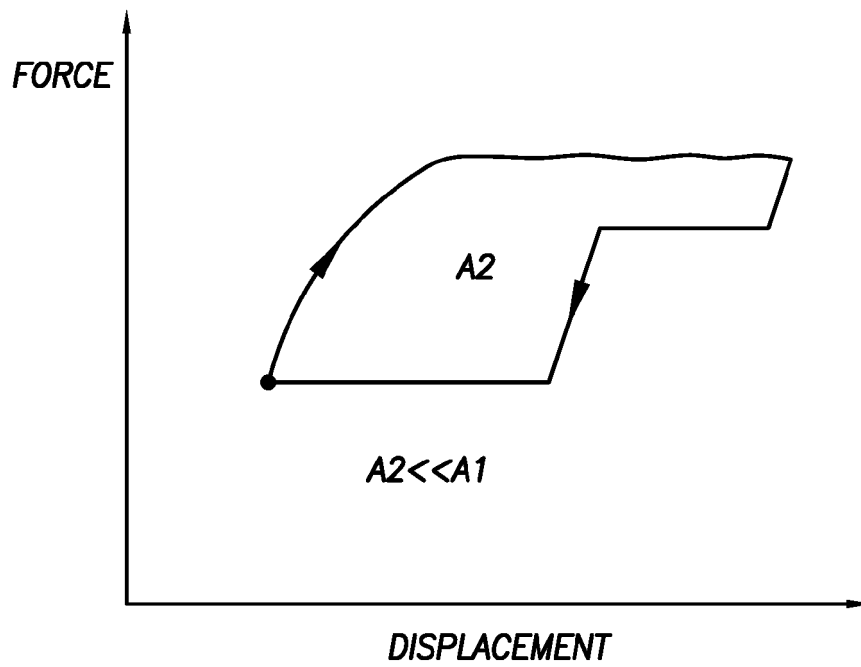

FIG.8A



$A2 \ll A1$

FIG.8B

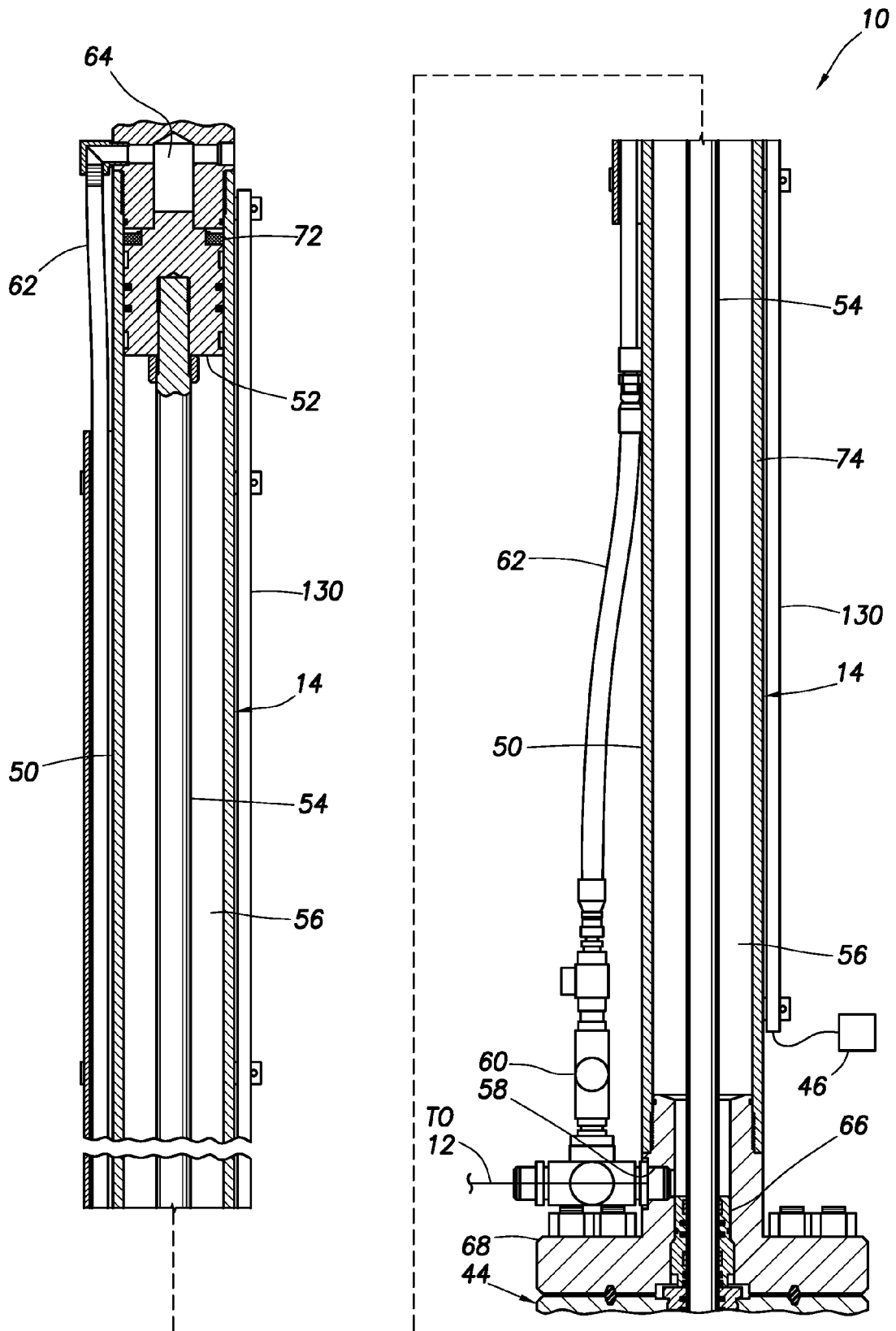

FIG.9

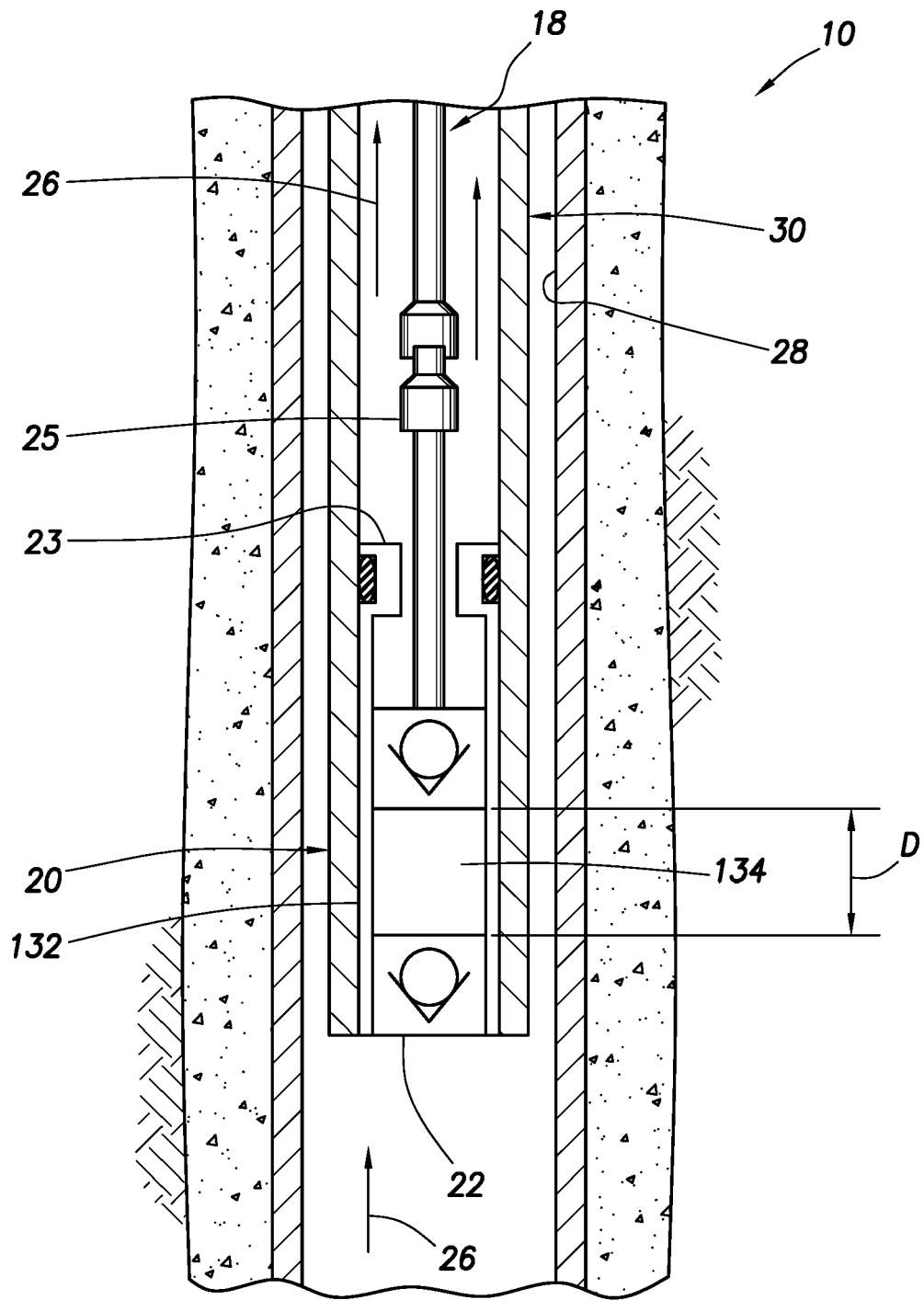

FIG. 10

REFERENCES CITED IN THE DESCRIPTION

This list of references cited by the applicant is for the reader's convenience only. It does not form part of the European patent document. Even though great care has been taken in compiling the references, errors or omissions cannot be excluded and the EPO disclaims all liability in this regard.

Patent documents cited in the description

- US 14956527 B [0001]
- US 14956545 B [0001]
- US 14956601 B [0001]
- US 14956863 B [0001]
- US 1543694 W [0001]

Non-patent literature cited in the description

- **EVERITT, T.A. ; JENNINGS, J.W.** An Improved Finite-Difference Calculation of Downhole Dynamometer Cards for Sucker-Rod Pumps. *SPE*, February 1992, vol. 18189 [0127]