

(19) World Intellectual Property Organization  
International Bureau



(43) International Publication Date  
28 June 2007 (28.06.2007)

PCT

(10) International Publication Number  
**WO 2007/073372 A1**

(51) International Patent Classification:  
*F25D 11/00* (2006.01) *E04B 2/30* (2006.01)

(74) Agent: WALL, Thomas J.; 101 South Salina Street, Suite 400, Syracuse, New York 13202 (US).

(21) International Application Number:  
PCT/US2005/046569

(81) Designated States (unless otherwise indicated, for every kind of national protection available): AE, AG, AL, AM, AT, AU, AZ, BA, BB, BG, BR, BW, BY, BZ, CA, CH, CN, CO, CR, CU, CZ, DE, DK, DM, DZ, EC, EE, EG, ES, FI, GB, GD, GE, GH, GM, HR, HU, ID, IL, IN, IS, JP, KE, KG, KM, KN, KP, KR, KZ, LC, LK, LR, LS, LT, LU, LV, LY, MA, MD, MG, MK, MN, MW, MX, MZ, NA, NG, NI, NO, NZ, OM, PG, PH, PL, PT, RO, RU, SC, SD, SE, SG, SK, SL, SM, SY, TJ, TM, TN, TR, TT, TZ, UA, UG, US, UZ, VC, VN, YU, ZA, ZM, ZW.

(22) International Filing Date:  
22 December 2005 (22.12.2005)

(25) Filing Language: English

(26) Publication Language: English

(71) Applicant (for all designated States except US): **CARRIER CORPORATION** [US/US]; One Carrier Place, Farmington, Connecticut 06034 (US).

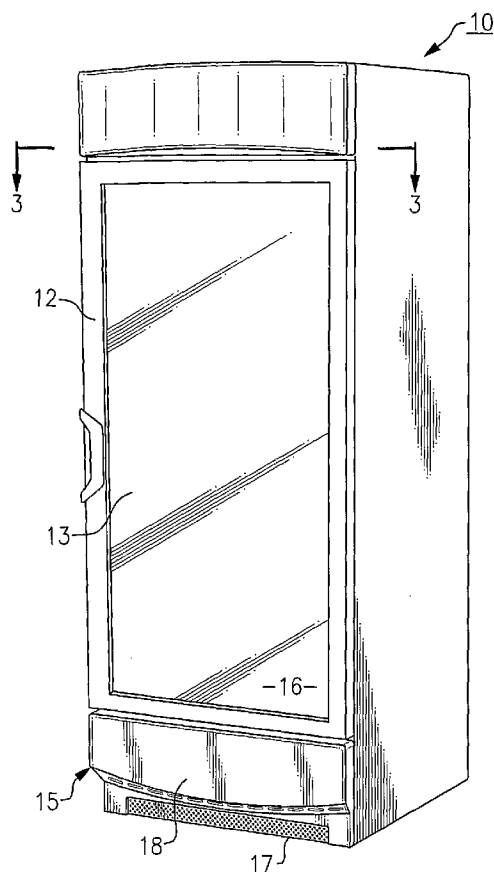
(84) Designated States (unless otherwise indicated, for every kind of regional protection available): ARIPO (BW, GH, GM, KE, LS, MW, MZ, NA, SD, SL, SZ, TZ, UG, ZM, ZW), Eurasian (AM, AZ, BY, KG, KZ, MD, RU, TJ, TM), European (AT, BE, BG, CH, CY, CZ, DE, DK, EE, ES, FI, FR, GB, GR, HU, IE, IS, IT, LT, LU, LV, MC, NL, PL, PT, RO, SE, SI, SK, TR), OAPI (BF, BJ, CF, CG, CI, CM, GA, GN, GQ, GW, ML, MR, NE, SN, TD, TG).

(72) Inventor; and

(75) Inventor/Applicant (for US only): **AVILA, Luis F.** [MX/US]; 4582 Pauli Drive, Manlius, New York 13104 (US).

[Continued on next page]

(54) Title: INTERLOCKING WALL SECTIONS FOR REFRIGERATED ENCLOSURES



(57) Abstract: Interlocking insulated wall sections (20-24), each of which contains a shell (30) having an outer panel (33) and a pair of end walls (35-36). A cover (31) is having an inner panel (38) and two end walls (39-40) is fitted over the shell. A first end wall (39) of the cover is mounted in contact with an end wall (35) of the shell and a second end wall (40) of the cover passes into the shell between the two end walls of the shell. An L-shaped flange (43) is connected to the second end wall of the cover and has a first leg of the flange (44) that rests in contact with the inner panel and a second leg of the flange (45) rests in contact with the other end wall of the shell. A space (50) is thus provided between the two panels of the wall section and is filled with an insulation (55). Each wall section is dimensioned so that it can be received in the opening between the second end wall of the cover and the end flange so that two wall sections can be interlocked together in assembly.

WO 2007/073372 A1



**Published:**

— with international search report

*For two-letter codes and other abbreviations, refer to the "Guidance Notes on Codes and Abbreviations" appearing at the beginning of each regular issue of the PCT Gazette.*

## **INTERLOCKING WALL SECTIONS FOR REFRIGERATED ENCLOSURES**

### **Field of the Invention**

[0001] This invention relates generally to interlocking insulated wall sections for use in the construction of structurally sound refrigerated enclosures.

### **Background of the Invention**

[0002] This invention relates more specifically to interlocking wall sections that are ideally suited for use in the construction of refrigerated merchandisers having an enclosed compartment for holding products in a relatively cool or cold environment. Many prior art refrigerated enclosures of this type employ modular corner units to attach the various insulated wall pieces in assembly. This type of construction required the use of a relatively large number of parts and the joints created by the modular corners are generally difficult to align and require special insulation and a large number of mechanical fasteners to complete. In addition, this type of construction does not allow for off-line fabrication of the various wall sections as subassemblies.

### **Summary of the Invention**

[0003] It is an object of this invention to improve the structural and thermal integrity of refrigerated enclosures.

[0004] It is a further object of the present invention to provide for improved structural joints at the corners of insulated walls of a refrigerated enclosure.

[0005] A still further object of the present invention is to improve the ease of assembly of a refrigerated assembly such as refrigerated merchandiser.

[0006] Another object of the invention is to allow for the off-line assembly of insulated wall sections of a refrigerated container whereby the sections can be easily brought together and interlocked in place at final assembly.

[0007] Yet another object of the present invention is to minimize the number of parts required to assemble a refrigerated enclosure.

[0008] These and other objects of the invention are attained by a wall section that contains a shell having an outer panel and two end walls integral with the outer

panel that are mounted perpendicular to the outer panel. A cover is mounted over the shell that has an inner panel and a first end wall and a second end wall. The first end wall of the cover is in contact with one end wall of the shell and the second end wall of the cover passes into the shell between one end wall of the shell and the other end wall of the tray. An L-shaped flange having a first leg that is connected to the distal end of the second end wall of the cover and a second leg that is mounted in contact with the other side wall of the tray. A space is established between the two wall panels, which is filled with insulation.

### **Brief Description of the Drawings**

[0009] For a further better understanding of these and other objects of the invention, reference will be made to the following detailed description of the invention which is to be read in association with the accompanying drawing, wherein:

[0010] Fig. 1 is a perspective view of a refrigerated merchandiser employing wall sections that embody the teachings of the invention;

[0011] Fig. 2 is a top view in section of a wall section that embodies the present invention;

[0012] Fig. 3 is a section taken along lines 3-3 in Fig. 1 showing a number of wall sections that embody the invention interlocked in assembly;

[0013] Fig. 4 is a partial top view showing a modified cover end flange;

[0014] Fig. 5 is also a partial top view showing a further modified cover end flange; and

[0015] Fig. 6 is an exploded view in perspective showing a second embodiment of the invention.

### **Description of the Invention**

[0016] Referring initially to Fig. 1-3 there is illustrated a refrigerated merchandiser, generally reference 10 that contains interlocking insulated wall sections which embody the teachings of the present invention. Although the present invention will be described with specific reference to a refrigerated merchandiser, it should become evident from the disclosure below that the invention has wider

application and may be employed in association with any number of refrigerated enclosures requiring relatively strong insulated walls. The merchandiser includes a door 12 mounted in the front of the unit that opens into a refrigerated storage compartment for containing products such as canned and bottled beverages and other perishable or frozen consumables that necessitate storage within a controlled atmosphere. The door contains a transparent window 13 that allows a customer to view the contents of the unit without the need of opening the door.

[0017] The merchandiser includes a separate equipment compartment 15 that is isolated thermally from the refrigerated product compartment by means of an insulated floor panel 16. A refrigeration system (not shown) is housed within the equipment compartment that includes an evaporator unit and a condenser unit each being equipped with its own fan and being connected by a compressor in a conventional manner to produce a flow of refrigerated air from the system's evaporator into the product compartment. Warm air discharged from the condenser unit is passed out of the equipment compartment via a vent 17 located in the lower part of the merchandiser. An access panel 18 located over the vent which can be removed to allow a technician ready access to the refrigeration equipment.

[0018] Turning now to Fig. 2, the upper part of the merchandiser contains four insulated wall sections that are interlocked together so as to provide extremely tight joints at the corners to produce a rigid structure having high thermal integrity particularly in the corner regions. The four walls include two side walls 20 and 21, a back wall 23 which extend from the base of the unit to the top of the unit, and a front wall 24 that is foreshortened to accommodate the door and the equipment compartment access panel. Although now shown, the top of the unit is enclosed with an insulated ceiling panel.

[0019] Each wall section is of similar construction with the only differences is the section being found in the height and the width of the section.

[0020] As illustrated in Fig. 3, each wall section includes a shell 30 that is enclosed by cover 31. The shell includes an outer panel 33 and two opposed end walls 35 and 36 that are mounted perpendicular to the outer panel to create a channel shaped structure.

[0021] The cover 31 includes an inner panel 38 which also has two opposed end walls 39 and 40 that are mounted perpendicular to the inner panel. End wall 39 is mounted in contact with the outside surface of end wall 35 of the shell while the opposite end wall 40 of the cover passes downwardly into the shell. An L-shaped flange 43 protrudes outwardly from the end wall 40 towards the opposite end wall 36 of the shell. The flange contains a first leg 44 that is connected to the distal end of end wall 40 and which rests on the floor of the shell. The second leg 45 of the flange is turned outwardly 90° and rests in contact against the inside surface of end wall 36 of the shell. With the cover so mounted upon the shell the outer and inner panels of the wall section are held in parallel alignment with a space 50 being established between the two panels.

[0022] The shell and cover of each wall section is constructed of any suitable material, such as sheet metal, structural plastic, or any other suitable composite materials. The shell and cover of the wall section shown in Fig. 2 is formed from a single piece of sheet metal so that the individual sections of each are integrally joined. The end walls and the end flange each preferably extend across the entire width of the inner and outer panels, however in practice each may be broken up into a series of spaced apart segments without departing from the teachings of the present invention. When the wall sections are assembled as shown in Fig. 2, the cover can be secured to the shell using any one of well known fastening techniques such as mechanical fasteners, adhesive bonding, cladding, or pressure fits to form the desired hollow structure. Preferably, a tight sliding fit is provided between the shell and the cover so that the cover fits snugly within the shell.

[0023] As best illustrated, four wall sections can be interlocked at the four corners of the unit by simply inserting the unflanged end of one section into the flanged end of its neighbor. The dimension  $D_1$  over the two panels of each wall section is substantially equal to the inside dimension  $D_2$  of the cover flange to provide a close running fit between the two wall sections that form a corner section of the structure. This interlocking feature insures that a tight structural joint is established at the corners resulting in an overall rigid structure.

[0024] The space or cavity 50 within each wall section is filled with a thermal insulating material 55 which can be polyurethane foam, fiberglass sheets or

any other material that is capable of providing the necessary insulation. The joint formed by the interlocking wall sections insulates the corners of the enclosure providing for a thermally efficient assembly.

[0025] Turning now to Fig. 4, there is illustrated a further embodiment of the invention wherein the end flange 43 of the cover is provided with a stiffening plate 60 that is mounted within the corner that is established between the two legs of the end flange. The stiffening plate is mounted at a 45° between the legs and extends substantially along the width of the cover. As noted above, the cover provides a tight running fit between the two end walls of the shell in assembly and the stiffening plate serves to furnish greater rigidity to the structure which helps prevent the cover from being dislodged once it is closed.

[0026] Fig. 5 illustrates another embodiment of the invention wherein a detent 62 is established between the end flange 43 and the end wall 36 of the shell. The detent is formed by producing an outwardly protruding dimple 64 in the leg 45 of the flange adjacent to the flange corner and producing a complementary concave section 65 in the end wall 36. In this arrangement, the cover can be either snap fitted downwardly into the shell or moved laterally into the shell with the dimple of the flange in sliding relationship with the concave section of the end wall 36. The detent joint formed between the shell and the cover allows the cover to be more securely closed.

[0027] Fig. 6 is an exploded view of a wall section 70 that includes a shell 71 and a cover 72 as described above that are capable of closing together to establish a space between the shell panel 73 and the cover panel 74 for containing insulation. The wall section 70 is provided with two side caps 76 and 77 that can be snap fitted over open sides of the wall section assembly and secured in place using any suitable fastening means. One or both side caps are provided with a series of injection ports 79-79 through which an insulating foam material can be passed into the space between the cover panel and the shell panel.

[0028] While the present invention has been particularly shown and described with reference to the preferred mode as illustrated in the drawing, it will be understood by one skilled in the art that various changes in detail may be effected

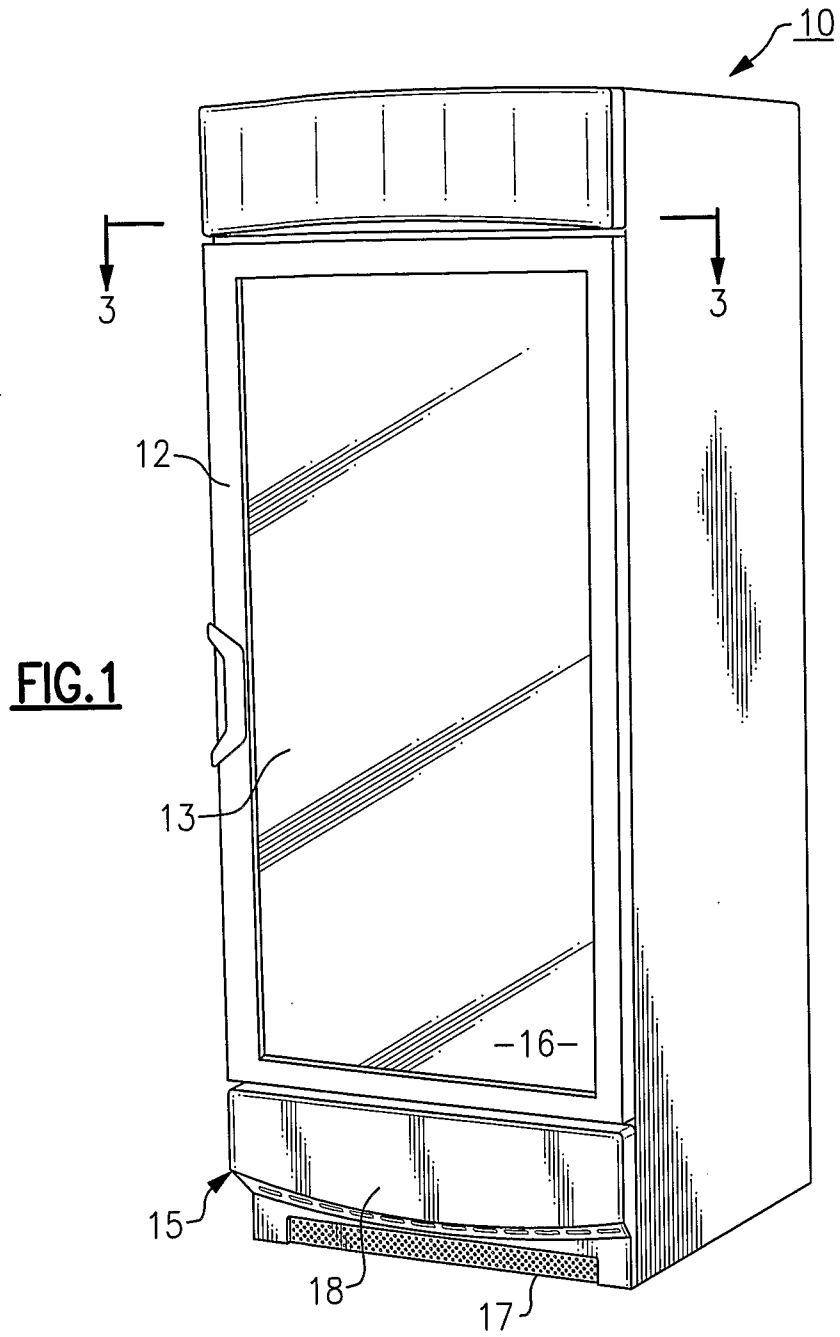
therein without departing from the spirit and scope of the invention as defined by the claims.

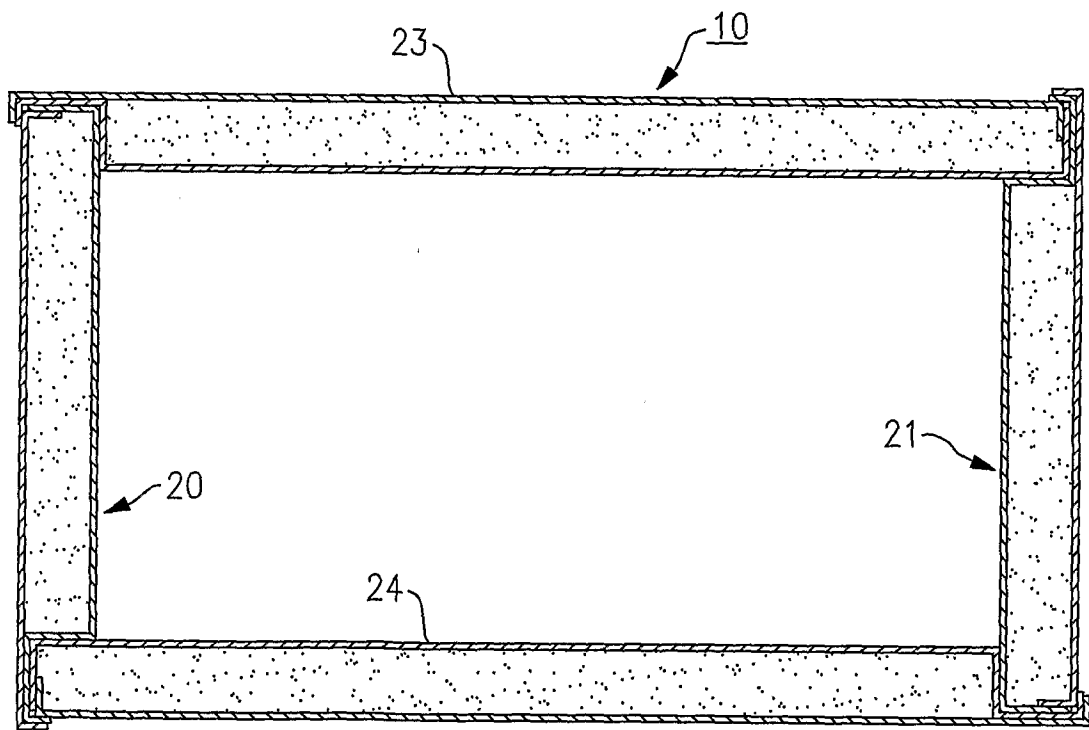
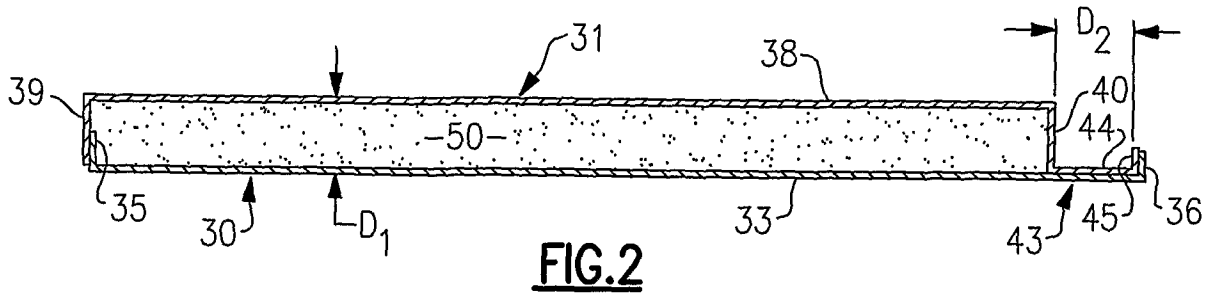


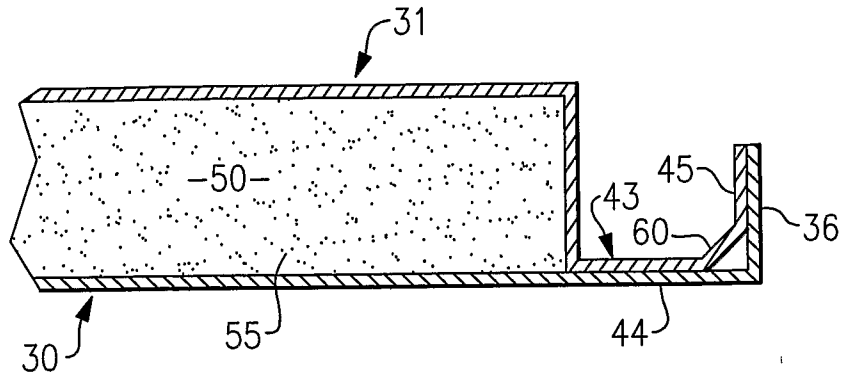
**We Claim:**

1. A wall section for use in a refrigerated enclosure that includes:
  - a shell having an outer panel and two parallel spaced apart end walls that are perpendicular to said outer panel;
  - a cover mounted over said shell that includes an inner panel having first and second end walls that are mounted perpendicular to said inner panel;
  - said first end wall being in contact with one end wall of said shell and said second end wall being mounted between the one end wall of the shell and the other end wall of the shell so that a space is established between the two panels; and
  - an L shaped flange having a first leg connected to the distal end of said second end wall of said cover and a second leg that is in contact with said other end wall of said shell whereby the inner and outer panels are perpendicularly aligned in assembly.
2. The wall section of claim 1 that further includes an insulation material located in the space between said panels.
3. The wall section of claim 1 wherein said first leg of said flange rests in contact with the outer panel of said shell.
4. The wall section of claim 1 wherein said shell and said cover are each fabricated from a single sheet of material.
5. The wall section of claim 4 wherein said shell and said cover are each fabricated of a structurally rigid material.
6. The wall section of claim 5 wherein said shell and said cover are each formed of sheet metal.
7. The wall section of claim 5 wherein said tray and said cover are each formed of a structural plastic material.

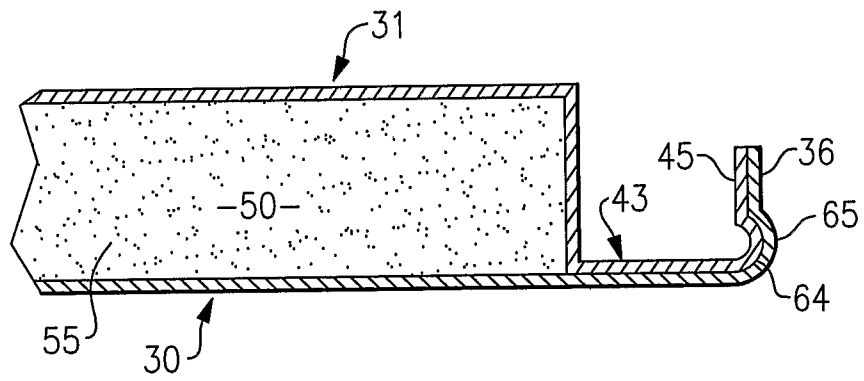
8. The wall section of claim 1 wherein the legs of said flange are joined by a corner piece that forms an acute angle with said outer panel.
9. The wall section of claim 1 that further includes a detent that acts between the second leg of the flange and the opposite side wall of the shell.
10. The wall section of claim 1 wherein the distance between the second end wall of the cover and the second leg of the flange is about equal to the distance over the shell and cover panels wherein said wall section can be interlocked with a second wall section having the same geometry.
11. The wall section of claim 1 that further includes side caps for enclosing the open space between the inner and outer panels.
12. The wall section of claim 11 wherein the side caps contain one or more injection ports through which insulation may be injected into the space between the inner and outer panels.



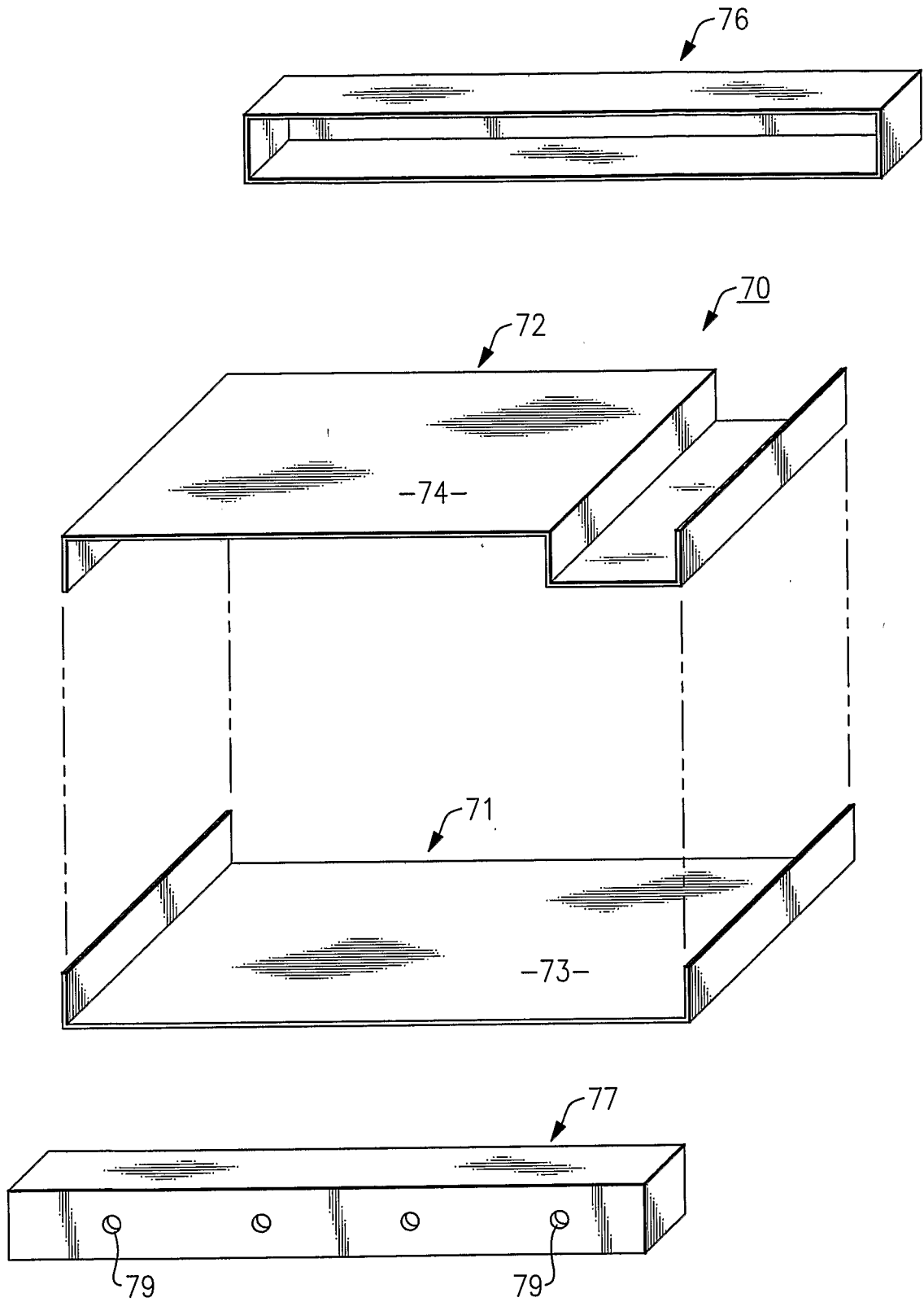




**FIG. 4**



**FIG. 5**



**FIG.6**

# INTERNATIONAL SEARCH REPORT

International application No.

PCT/US05/46569

**A. CLASSIFICATION OF SUBJECT MATTER**

IPC: F25D 11/00( 2006.01);E04B 2/30( 2006.01)

USPC: 52/786.13,309.14,783.1,784.13

According to International Patent Classification (IPC) or to both national classification and IPC

**B. FIELDS SEARCHED**

Minimum documentation searched (classification system followed by classification symbols)

U.S. : 52/786.13, 309.14, 783.1, 784.13

Documentation searched other than minimum documentation to the extent that such documents are included in the fields searched

Electronic data base consulted during the international search (name of data base and, where practicable, search terms used)

**C. DOCUMENTS CONSIDERED TO BE RELEVANT**

Category *	Citation of document, with indication, where appropriate, of the relevant passages	Relevant to claim No.
A	US 4,635,421 A (Newberg) 13 January 1987 13.01.1987, entire document	1-12
A	US 6,481,179 A (Zen) 19 November 2002 (19.11.2002), entire document	1-12
A	US 4,583,796 A (Nakajima et al) 22 April 1986 (22.04.1986), entire document	1-12

Further documents are listed in the continuation of Box C.

See patent family annex.

* Special categories of cited documents:	"T"
"A" document defining the general state of the art which is not considered to be of particular relevance	later document published after the international filing date or priority date and not in conflict with the application but cited to understand the principle or theory underlying the invention
"E" earlier application or patent published on or after the international filing date	"X" document of particular relevance; the claimed invention cannot be considered novel or cannot be considered to involve an inventive step when the document is taken alone
"L" document which may throw doubts on priority claim(s) or which is cited to establish the publication date of another citation or other special reason (as specified)	"Y" document of particular relevance; the claimed invention cannot be considered to involve an inventive step when the document is combined with one or more other such documents, such combination being obvious to a person skilled in the art
"O" document referring to an oral disclosure, use, exhibition or other means	"&" document member of the same patent family
"P" document published prior to the international filing date but later than the priority date claimed	

Date of the actual completion of the international search

24 May 2006 (24.05.2006)

Date of mailing of the international search report

26 JUN 2006

Name and mailing address of the ISA/US

Mail Stop PCT, Attn: ISA/US  
Commissioner of Patents  
P.O. Box 1450  
Alexandria, Virginia 22313-1450

Facsimile No. (571) 273-3201

Authorized officer

Carl Friedman

Telephone No. (571) 272-3600