



US00D769488S

(12) **United States Design Patent**  
**Ma**

(10) **Patent No.:** **US D769,488 S**

(45) **Date of Patent:** **\*\* Oct. 18, 2016**

(54) **FRONT LIGHT FOR A VEHICLE**

(71) Applicant: **Foshan Tuff Plus Auto Lighting Co., Ltd.**, Foshan, Guangdong (CN)

(72) Inventor: **Yong Ma**, Guangdong (CN)

(73) Assignee: **Foshan Tuff Plus Auto Lighting Co., Ltd.**, Foshan, Guangdong (CN)

(\*\*) Term: **15 Years**

(21) Appl. No.: **29/537,752**

(22) Filed: **Aug. 28, 2015**

(51) **LOC (10) Cl.** ..... **26-06**

(52) **U.S. Cl.**

USPC ..... **D26/28**

(58) **Field of Classification Search**

USPC ..... D26/28-36; 362/459-468, 475-478, 362/485-487

CPC ..... F21S 48/00; F21S 48/10; F21S 48/115; F21S 48/225; F21S 48/1233; F21S 48/1266; F21S 48/1388; F21S 48/2268; F21V 21/04

See application file for complete search history.

(56) **References Cited**

**U.S. PATENT DOCUMENTS**

D547,889 S \* 7/2007 Huang ..... D26/28  
D570,012 S \* 5/2008 Huang ..... D26/28

D578,678 S \* 10/2008 Huang ..... D26/28  
D592,778 S \* 5/2009 Chang ..... D26/28  
D606,682 S \* 12/2009 Chang ..... D26/28  
D645,177 S \* 9/2011 Okuda ..... D12/345  
D662,632 S \* 6/2012 Wilson ..... D26/28

\* cited by examiner

*Primary Examiner* — Marcus Jackson

(74) *Attorney, Agent, or Firm* — Sand & Sebolt

(57) **CLAIM**

The ornamental design for a front light for a vehicle, as shown and described.

**DESCRIPTION**

FIG. 1 is an isometric perspective view of a front light for a vehicle in accordance with my design; FIG. 2 is a front elevation thereof; FIG. 3 is a rear elevation thereof; FIG. 4 is a top plan view thereof; FIG. 5 is a bottom plan view thereof; FIG. 6 is a left side elevation thereof; and, FIG. 7 is a right side elevation thereof. The broken lines illustrate portions of the front light for a vehicle which form no part of the claimed design.

**1 Claim, 6 Drawing Sheets**

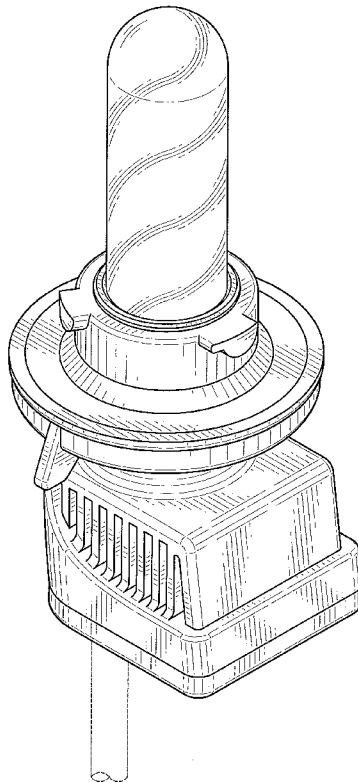

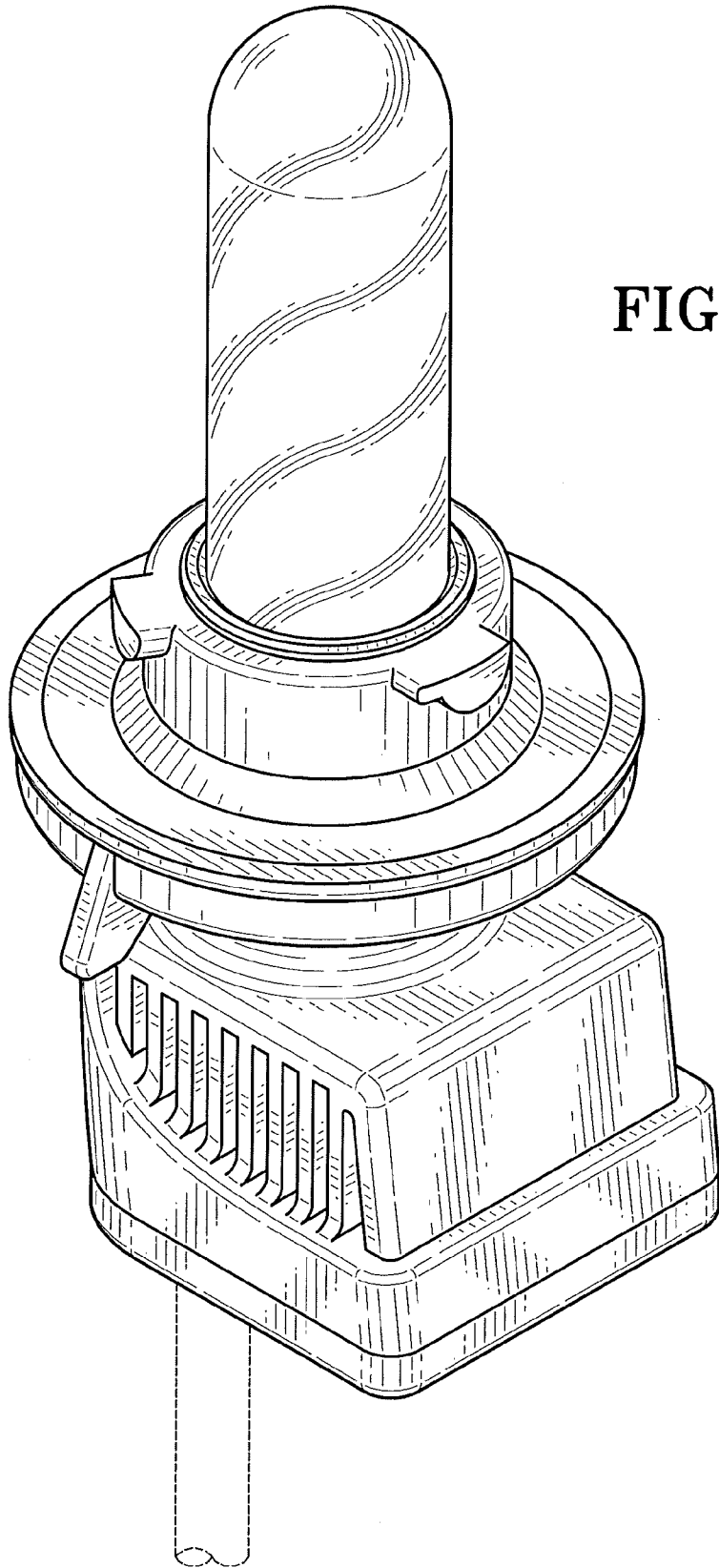

FIG-1

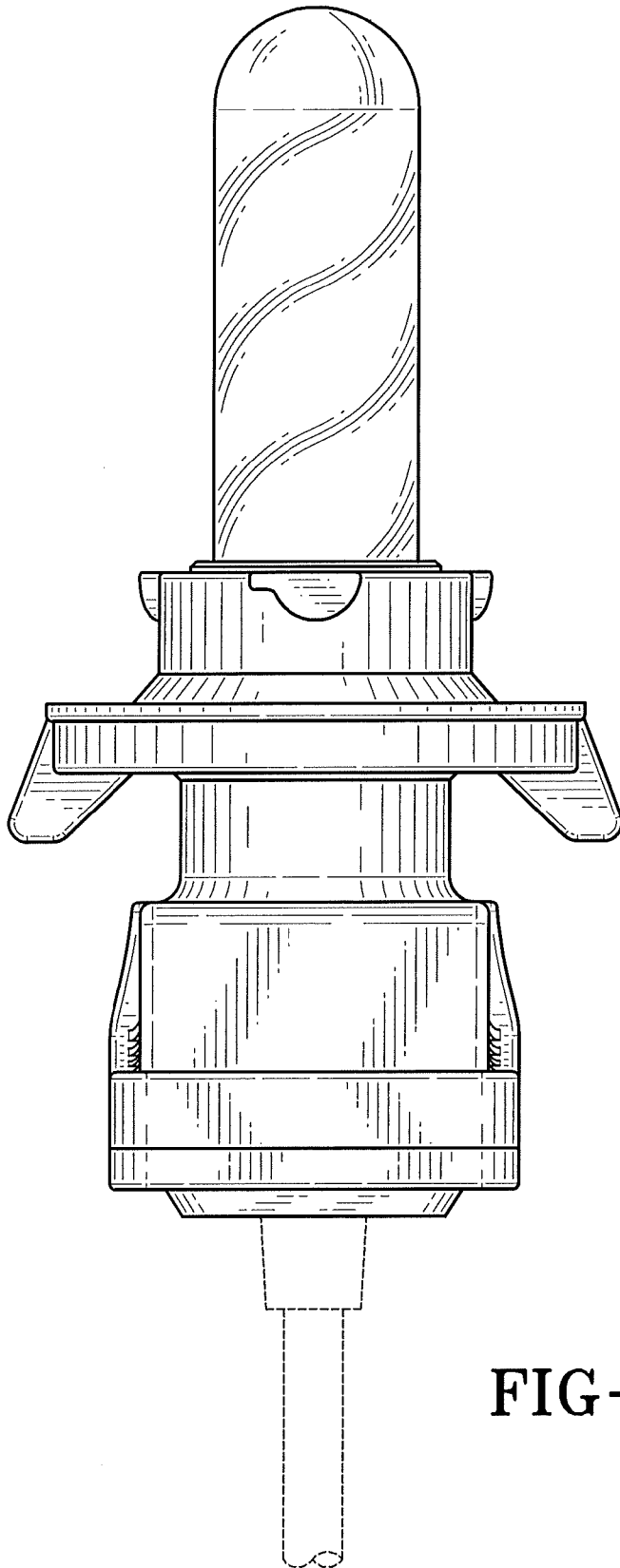

FIG-2

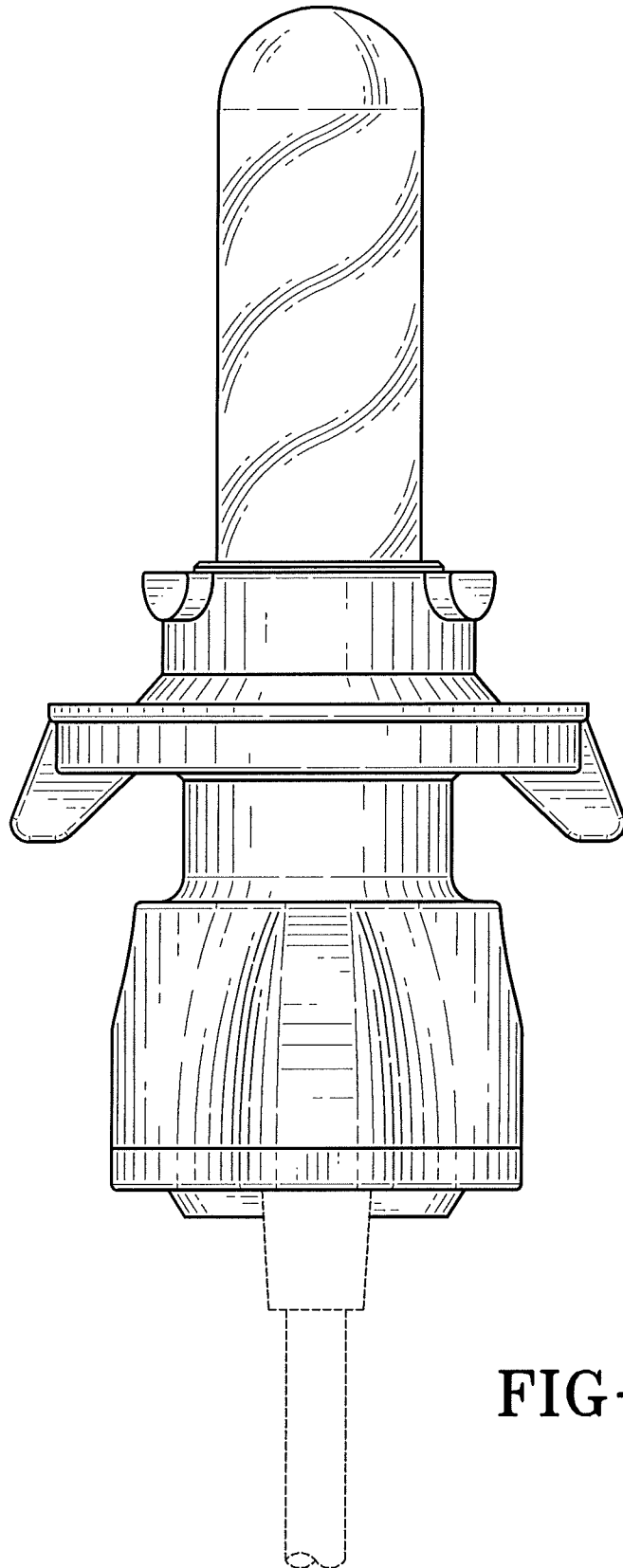

FIG-3

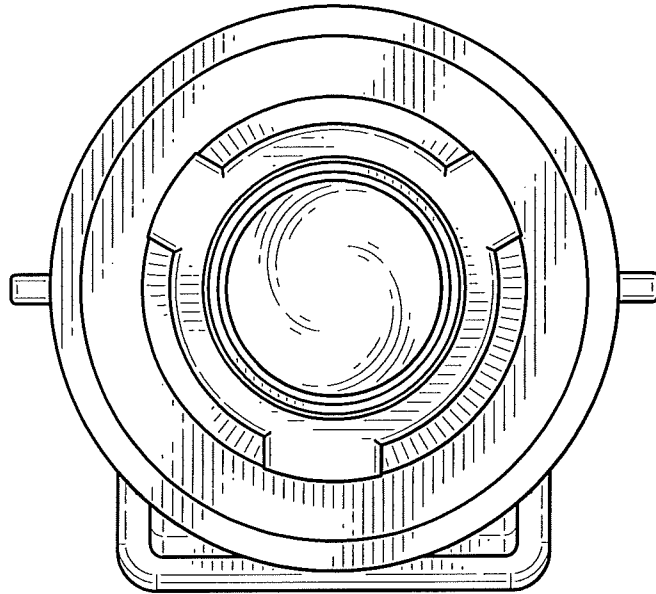

FIG-4

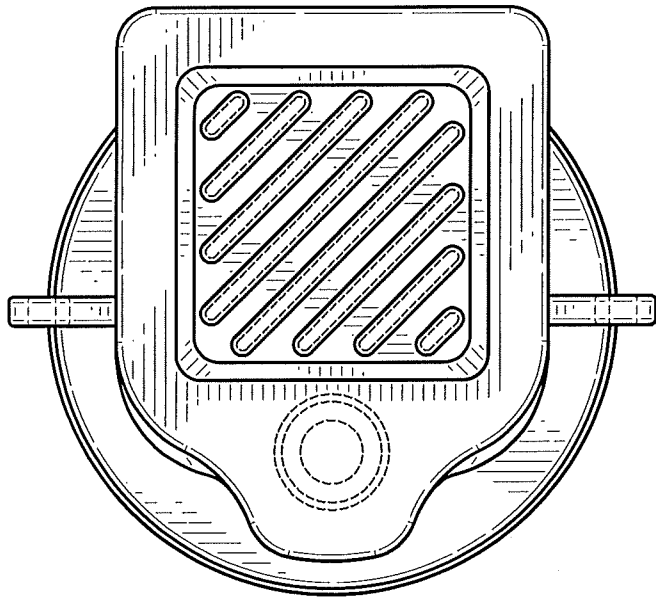

FIG-5

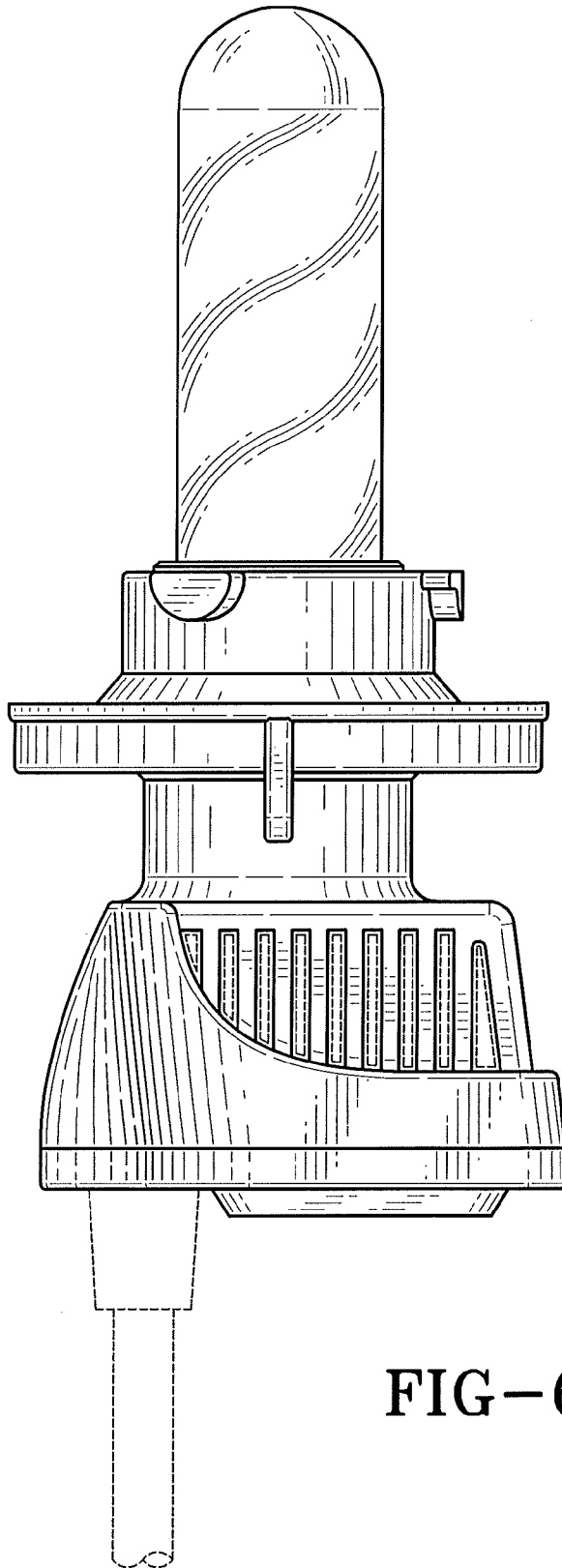

FIG-6

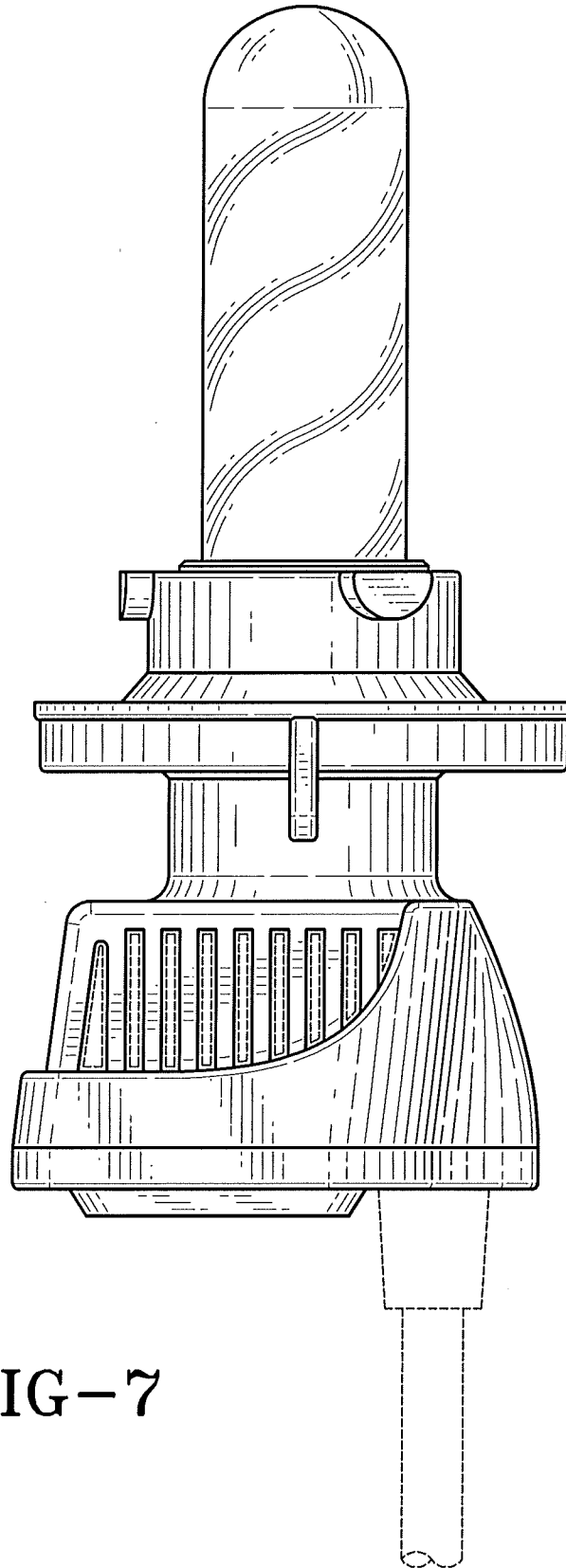

FIG-7