



US 20040188327A1

(19) **United States**

(12) **Patent Application Publication**

Groten

(10) **Pub. No.: US 2004/0188327 A1**

(43) **Pub. Date: Sep. 30, 2004**

(54) **PROCESS FOR SULFUR REDUCTION IN NAPHTHA STREAMS**

(52) **U.S. Cl. 208/210; 208/211; 208/212**

(75) **Inventor: Willibrord A. Groten, Houston, TX (US)**

(57) **ABSTRACT**

Correspondence Address:
**KENNETH H. JOHNSON
P.O. BOX 630708
HOUSTON, TX 772630000**

(73) **Assignee: CATALYTIC DISTILLATION TECHNOLOGIES**

(21) **Appl. No.: 10/015,863**

(22) **Filed: Dec. 12, 2001**

Related U.S. Application Data

(60) **Provisional application No. 60/299,508, filed on Jun. 20, 2001. Provisional application No. 60/315,161, filed on Aug. 27, 2001.**

Publication Classification

(51) **Int. Cl.⁷ C10G 45/02; C10G 65/04**

A process for fractionating and treating of a full range naphtha stream. The full boiling range naphtha stream is first split into a light boiling range naphtha, an intermediate boiling range naphtha and a heavy boiling range naphtha. The bottoms are subjected to hydrodesulfurization and the effluent combined with the intermediate boiling range naphtha containing thiophene and thiophene boiling range mercaptans and subjected to a second hydrodesulfurization. The effluent from the polishing reactor may be combined with the light boiling range naphtha to produce a new full boiling range naphtha containing substantially less total sulfur than the original feed. The mercaptans in the light naphtha may be removed by thioetherification prior to splitting or by wet caustic wash afterwards. The object being to meet higher standards for sulfur removal, by treating the components of the naphtha feed with the process that preserves the olefinic while most expediently removing the sulfur compounds.

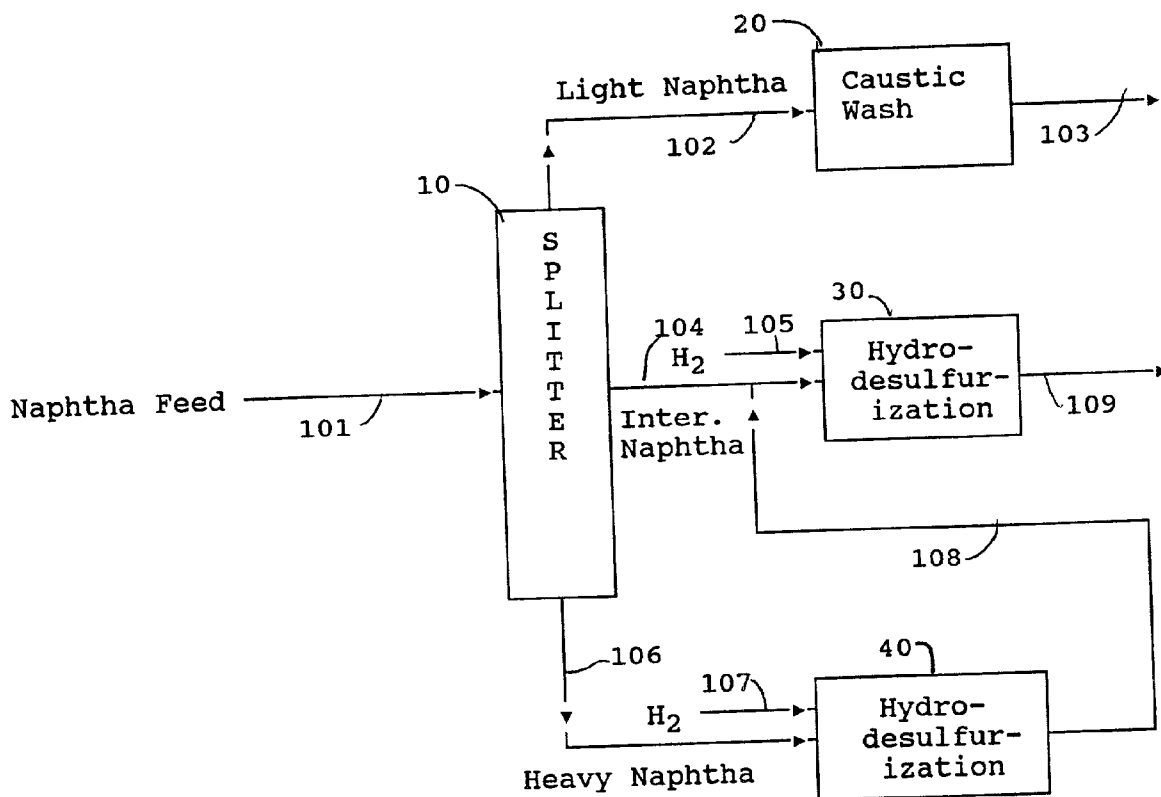

FIG. 1

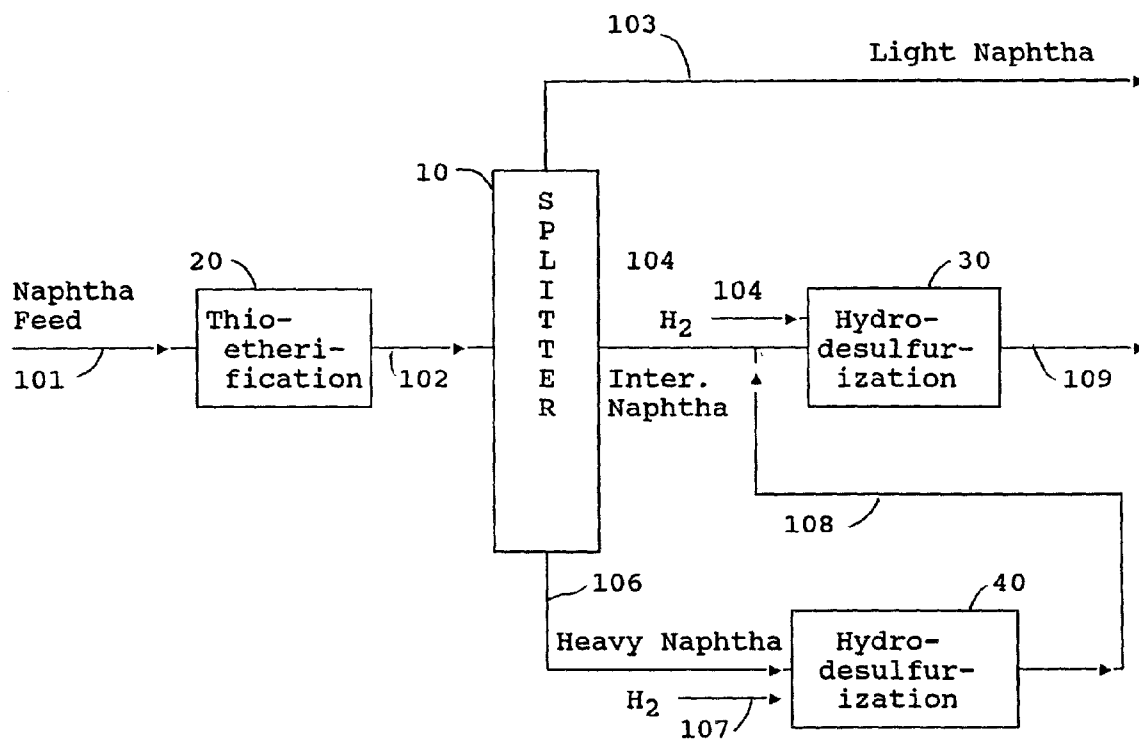

FIG. 2

PROCESS FOR SULFUR REDUCTION IN NAPHTHA STREAMS

BACKGROUND OF THE INVENTION

[0001] 1. Field of the Invention

[0002] The present invention relates to a process for concurrently fractionating and hydrotreating a full range naphtha stream. More particularly the full boiling range naphtha stream is split into a light boiling range naphtha, a medium boiling range naphtha and a heavy boiling range naphtha. Each boiling range naphtha is treated separately to achieve a combined desired total sulfur content.

[0003] 2. Related Information

[0004] Petroleum distillate streams contain a variety of organic chemical components. Generally the streams are defined by their boiling ranges which determine the compositions. The processing of the streams also affects the composition. For instance, products from either catalytic cracking or thermal cracking processes contain high concentrations of olefinic materials as well as saturated (alkanes) materials and polyunsaturated materials (diolefins). Additionally, these components may be any of the various isomers of these compounds.

[0005] The composition of untreated naphtha as it comes from the crude still, or straight run naphtha, is primarily influenced by the crude source. Naphthas from paraffinic crude sources have more saturated straight chain or cyclic compounds. As a general rule most of the "sweet" (low sulfur) crudes and naphthas are paraffinic. The naphthenic crudes contain more unsaturates and cyclic and polycyclic compounds. The higher sulfur content crudes tend to be naphthenic. Treatment of the different straight run naphthas may be slightly different depending upon their composition due to crude source.

[0006] Reformed naphtha or reformat generally requires no further treatment except perhaps distillation or solvent extraction for valuable aromatic product removal. Reformed naphthas have essentially no sulfur contaminants due to the severity of their pretreatment for the process and the process itself.

[0007] Cracked naphtha as it comes from the catalytic cracker has a relatively high octane number as a result of the olefinic and aromatic compounds contained therein. In some cases this fraction may contribute as much as half of the gasoline in the refinery pool together with a significant portion of the octane.

[0008] Catalytically cracked naphtha gasoline boiling range material currently forms a significant part ($\approx 1/3$) of the gasoline product pool in the United States and it provides the largest portion of the sulfur. The sulfur impurities may require removal, usually by hydrotreating, in order to comply with product specifications or to ensure compliance with environmental regulations.

[0009] The most common method of removal of the sulfur compounds is by hydrodesulfurization (HDS) in which the petroleum distillate is passed over a solid particulate catalyst comprising a hydrogenation metal supported on an alumina base. Additionally copious quantities of hydrogen are

included in the feed. The following equations illustrate the reactions in a typical HDS unit:



[0010] Typical operating conditions for the HDS reactions are:

Temperature, ° F.	600–780
Pressure, psig	600–3000
H ₂ recycle rate, SCF/bbl	1500–3000
Fresh H ₂ makeup, SCF/bbl	700–1000

[0011] The reaction of organic sulfur compounds in a refinery stream with hydrogen over a catalyst to form H₂S is typically called hydrodesulfurization. Hydrotreating is a broader term which includes saturation of olefins and aromatics and the reaction of organic nitrogen compounds to form ammonia. However hydrodesulfurization is included and is sometimes simply referred to as hydrotreating.

[0012] After the hydrotreating is complete, the product may be fractionated or simply flashed to release the hydrogen sulfide and collect the now desulfurized naphtha.

[0013] In addition to supplying high octane blending components the cracked naphthas are often used as sources of olefins in other processes such as etherifications. The conditions of hydrotreating of the naphtha fraction to remove sulfur will also saturate some of the olefinic compounds in the fraction reducing the octane and causing a loss of source olefins.

[0014] Various proposals have been made for removing sulfur while retaining the more desirable olefins. Since the olefins in the cracked naphtha are mainly in the low boiling fraction of these naphthas and the sulfur containing impurities tend to be concentrated in the high boiling fraction the most common solution has been prefractionation prior to hydrotreating. The prefractionation produces a light boiling range naphtha which boils in the range of C₅ to about 250° F. and a heavy boiling range naphtha which boils in the range of from about 250–475° F.

[0015] The predominant light or lower boiling sulfur compounds are mercaptans while the heavier or higher boiling compounds are thiophenes and other heterocyclic compounds. The separation by fractionation alone will not remove the mercaptans. However, in the past the mercaptans were frequently removed by oxidative processes involving caustic washing. A combination oxidative removal of the mercaptans followed by fractionation and hydrotreating of the heavier fraction is disclosed in U.S. Pat. No. 5,320,742. In the oxidative removal of the mercaptans the mercaptans are converted to the corresponding disulfides.

[0016] In addition to treating the lighter portion of the naphtha to remove the mercaptans the lighter fraction traditionally has been used as feed to a catalytic reforming unit to increase the octane number if necessary. Also the lighter fraction may be subjected to further separation to remove the valuable C₅ olefins (amylenes) which are useful in preparing ethers.

[0017] Simultaneous treatment and fractionation of petroleum products, including naphtha, especially fluid catalyti-

cally cracked naphtha (FCC naphtha) is disclosed in U.S. Pat. Nos. 5,510,568; 5,597,476; 5,779,883; 5,807,477 and 6,083,378.

[0018] U.S. Pat. No. 5,510,568 for example discloses full boiling range FCC naphtha hydrotreated in a splitter which contains a thioetherification catalyst in the upper portion. Mercaptans in the light fraction react with the diolefins contained therein (thioetherification) to produce higher boiling sulfides which are removed as bottoms along with the heavy (higher boiling) FCC naphtha.

[0019] It has now been found that the light FCC naphtha cut in the splitter just below the light fraction also contains mercaptans and a significant amount of thiophenes. The mercaptans in this cut may be removed by the thioetherification. The total sulfur content of the thiophene cut is relatively low and more significantly does not require as severe treatment as the sulfur compounds in the heavy fraction to convert the thiophene to H_2S , thus the olefins in the thiophene cut are less likely to be hydrogenated.

[0020] It is an advantage of the present invention that the sulfur may be removed from the light olefin portion of the stream to a heavier portion of the stream without any substantial loss of olefins. Substantially all of the sulfur in the heavier portion is converted to H_2S by hydrodesulfurization and easily distilled away from the hydrocarbons. Also, the sulfur in the middle cut will also be lowered.

SUMMARY OF THE INVENTION

[0021] Briefly the present invention is a process for removal of sulfur from a full boiling range fluid cracked naphtha stream to meet higher standards for sulfur removal, by splitting the light portion of the stream and treating the components of the naphtha feed with the process that preserves the olefinic while most expediently removing the sulfur compounds.

[0022] Preferably the process comprises the steps of:

[0023] (a) separating the full boiling range cracked naphtha stream into three fractions comprising a light cracked naphtha fraction, preferably boiling in the range of C_5 to about $150^\circ F.$, an intermediate cracked naphtha fraction preferably boiling in the range of about 150 to about $250^\circ F.$ and a heavy cracked naphtha preferably boiling in the range of about 250 to $450^\circ F.$;

[0024] (b) subjecting the heavy cracked naphtha to hydrodesulfurization in a first hydrodesulfurization reactor containing a hydrodesulfurization catalyst; and

[0025] (c) combining the effluent from the first hydrodesulfurization reactor with the intermediate cracked naphtha and subjecting the combined stream to hydrodesulfurization in a second hydrodesulfurization reactor.

[0026] The advantage of this system is that the size and capital investment of the hydrodesulfurization distillation column reactor are reduced. The level of recombinant mercaptans coming for the hydrodesulfurization distillation column is reduced. Finally there is a potential savings in octane due to the milder treatment of the olefin rich thiophene cut.

BRIEF DESCRIPTION OF THE DRAWINGS

[0027] FIG. 1 is a simplified flow diagram of one embodiment of the invention.

[0028] FIG. 2 is a simplified flow diagram of an alternative embodiment having a having a thioetherification pretreatment.

DETAILED DESCRIPTION OF THE INVENTION

[0029] The feed to the process comprises a sulfur-containing petroleum fraction which boils in the gasoline boiling range. Feeds of this type include light naphthas having a boiling range of about C_5 to $330^\circ F.$ and full range naphthas having a boiling range of C_5 to $420^\circ F.$ Generally the process is useful on the naphtha boiling range material from catalytic cracker products because they contain the desired olefins and unwanted sulfur compounds. Straight run naphthas have very little olefinic material, and unless the crude source is "sour", very little sulfur.

[0030] The sulfur content of the catalytically cracked fractions will depend upon the sulfur content of the feed to the cracker as well as the boiling range of the selected fraction used as feed to the process. Lighter fractions will have lower sulfur contents than higher boiling fractions. The front end of the naphtha contains most of the high octane olefins but relatively little of the sulfur. The sulfur components in the front end are mainly mercaptans and typical of those compounds are: methyl mercaptan (b.p. $43^\circ F.$), ethyl mercaptan (b.p. $99^\circ F.$), n-propyl mercaptan (b.p. $154^\circ F.$), iso-propyl mercaptan (b.p. $135-140^\circ F.$), iso-butyl mercaptan (b.p. $190^\circ F.$), tert-butyl mercaptan (b.p. $147^\circ F.$), n-butyl mercaptan (b.p. $208^\circ F.$), sec-butyl mercaptan (b.p. $203^\circ F.$) and 3-mercapto hexane (b.p. $135^\circ F.$). Typical sulfur compounds found in the heavier boiling fraction include the heavier mercaptans, thiophenes sulfides and disulfides.

[0031] The reaction of these mercaptans with diolefins contained within the naphtha is called thioetherification and the products are higher boiling sulfides. A suitable catalyst for the reaction of the diolefins with the mercaptans is 0.4 wt. % Pd on 7 to 14 mesh Al_2O_3 (alumina) spheres, supplied by Süd-Chemie, designated as G-68C-1. Typical physical and chemical properties of the catalyst as provided by the manufacturer are as follows:

TABLE I

Designation	G-68C-1
Form	Spheres
Nominal size	7 × 12 mesh
Pd. wt. %	0.4 ± 0.03
Support	High purity alumina (99.0–99.5)

[0032] Another catalyst useful for the mercaptan-diolefin reaction is Ni silica/alumina extrudates, supplied by Süd-Chemie, designated as C46-7-03RS. Typical physical and chemical properties of the catalyst as provided by the manufacturer are as follows:

TABLE II

Designation	046-7-03 RS
Form	Extrudate

TABLE II-continued

Nominal size	1/16"
Ni wt. %	52 ± 4
Support	Silica/Alumina

[0033] The hydrogen rate to the reactor must be sufficient to maintain the reaction, but which is understood to be the "effectuating amount of hydrogen" as that term is used herein. The mole ratio of hydrogen to diolefins and acetylenes in the feed is at least 1.0 to 1.0 and preferably 2.0 to 1.0.

[0034] Another method suitable for removing mercaptans from a light naphtha is the wet caustic washing process. In such a process the light naphtha is contacted with caustic. The mercaptans are solublized into the aqueous caustic phase. The mercaptans are then reacted to form disulfides. The amount of mercaptan extracted is limited by the solubility of the mercaptan in the caustic solution.

[0035] Catalyst which are useful for the hydrodesulfurization reaction include Group VIII metals such as cobalt, nickel, palladium, alone or in combination with other metals such as molybdenum or tungsten on a suitable support which may be alumina, silica-alumina, titania-zirconia or the like. Normally the metals are provided as the oxides of the metals supported on extrudates or spheres and as such are not generally useful as distillation structures.

[0036] The catalysts contain components from Group V, VIB, VIII metals of the Periodic Table or mixtures thereof. The use of the distillation system reduces the deactivation and provides for longer runs than the fixed bed hydrogenation units of the prior art. The Group VIII metal provides increased overall average activity. Catalysts containing a Group VIB metal such as molybdenum and a Group VIII metal such as cobalt or nickel are preferred. Catalysts suitable for the hydrodesulfurization reaction include cobalt-molybdenum, nickel-molybdenum and nickel-tungsten. The metals are generally present as oxides supported on a base such as alumina, silica-alumina or the like. The metals are reduced to the sulfide either in use or prior to use by exposure to sulfur compound containing streams. The catalyst may also catalyze the hydrogenation of the olefins and polyolefins contained within the light cracked naphtha and to a lesser degree the isomerization of some of the mono-olefins. The hydrogenation, especially of the mono-olefins in the lighter fraction may not be desirable.

[0037] Typical preferred conditions for the thioetherification reaction in a standard down flow fixed bed reactor include temperatures in the range of 170 to 400° F., pressures of 145 to 290 psia and liquid hourly space velocities of 1 to 10 vol. of naphtha/volume of catalyst/hr.

[0038] The properties of a typical hydrodesulfurization catalyst are shown in Table I below.

TABLE III

Manufacture	Criterion Catalyst Co.
Designation	C-448
Form	Tri-lobe Extrudate
Nominal size	1.2 mm diameter

TABLE III-continued

Metal, Wt. %	
Cobalt	2-5%
Molybdenum	5-20%
Support	Alumina

[0039] The catalyst typically is in the form of extrudates having a diameter of 1/8, 1/16 or 1/32 inches and an L/D of 1.5 to 10. The catalyst also may be in the form of spheres having the same diameters. They may be directly loaded into standard straight pass fixed bed reactors which include supports and reactant distribution structures.

[0040] Reaction conditions for sulfur removal only in a standard straight pass fixed bed reactor are in the range of 500-700° F. at pressures of between 400-1000 psig. Residence times expressed as liquid hourly space velocity are generally typically between 1.0 and 10. The naphtha in the straight pass fixed bed reaction may be in the liquid phase or gaseous phase depending on the temperature and pressure, with total pressure and hydrogen gas rate adjusted to attain hydrogen partial pressures in the 100-700 psia range. The operation of the straight pass fixed bed hydrodesulfurization is otherwise well known in the art.

[0041] Referring now to the FIG. 1 a simplified flow diagram in schematic form of one embodiment is shown. The naphtha feed enters a naphtha splitter **10** via flow line **101**. A light naphtha containing mostly C₅'s is taken as overheads via flow line **102**. The light naphtha also contains most of the mercaptans and little other organic compounds. An intermediate naphtha boiling in the range of C₆ to about 300° F. is taken via flow line **104** as a side draw. The intermediate naphtha containing predominantly thiophenes along with some mercaptans. A heavy naphtha boiling in the range of 300-450° F. is taken as bottoms via flow line **106**. The heavy naphtha may contain some thiophene but basically contains the heavier boiling organic sulfur compounds which for a better term are called other organic sulfur compounds.

[0042] The light naphtha in flow line **102** is treated by a wet caustic wash to in reactor **20** remove the mercaptans and taken as product via flow line **103** to be used primarily as feed to a tertiary amyl methyl ether process. The bottoms in flow line **106** is subjected to hydrodesulfurization in reactor **40** with hydrogen for the process being added via flow line **107**. In reactor **40** substantially all of the thiophene and most of the other organic sulfur compounds are converted to hydrogen sulfide which can easily be removed by flashing or distillation. The effluent from the reactor **40** is combined with the intermediate naphtha in flow line **104** and fed to a second hydrodesulfurization reactor **30** where hydrogen is added via flow line **105** for polishing. Basically the thiophene in the intermediate naphtha and the remaining organic sulfur compounds in the heavy naphtha are converted to hydrogen sulfide. A combined naphtha product is taken from reactor **30** via flow line **109**.

[0043] Referring now to FIG. 2 a second embodiment is shown. The entire naphtha feed is fed via flow line **101** to a thioetherification reactor **20** where the diolefins in the naphtha react with the mercaptans to sulfides. The effluent from the reactor **20** is fed via flow line **102** to the naphtha splitter

10 where the naphtha is split into three fractions. A light naphtha containing mostly C_5 's is taken as overheads via flow line **103**. Because the mercaptans have been removed in the thioetherification reactor the light naphtha contains very little organic sulfur. An intermediate naphtha boiling in the range of C_6 to about 300° is taken via flow line **104** as a side draw. The intermediate naphtha containing predominantly thiophenes along with some mercaptans. A heavy naphtha boiling in the range of 300 - 450° is taken as bottoms via flow line **106**. The heavy naphtha may contain some thiophene but basically contains the heavier boiling organic sulfur compounds which for a better term are called other organic sulfur compounds.

[**0044**] The bottoms in flow line **106** is subjected to hydrodesulfurization in reactor **40** with hydrogen for the process being added via flow line **107**. In reactor **40** substantially all of the thiophene and most of the other organic sulfur compounds are converted to hydrogen sulfide which can easily be removed by flashing or distillation. The effluent from the reactor **40** is combined with the intermediate naphtha in flow line **104** and fed to a second hydrodesulfurization reactor **30** where hydrogen is added via flow line **105** for polishing. Basically the thiophene in the intermediate naphtha and the remaining organic sulfur compounds in the heavy naphtha are converted to hydrogen sulfide. A combined naphtha product is taken from reactor **30** via flow line **109**.

The invention claimed is:

1. A process for reducing the organic sulfur content of a full boiling range cracked naphtha stream containing olefins, diolefins, mercaptans, thiophenes, and other organic sulfur compounds, comprising the steps of:

- (a) separating the full boiling range cracked naphtha stream into three fractions comprising a light cracked naphtha fraction, an intermediate cracked naphtha fraction and a heavy cracked naphtha;
- (b) subjecting the heavy cracked naphtha to hydrodesulfurization in a first hydrodesulfurization reactor containing a hydrodesulfurization catalyst; and
- (c) combining the effluent from the first hydrodesulfurization reactor with the intermediate cracked naphtha and subjecting the combined stream to hydrodesulfurization in a second hydrodesulfurization reactor.

2. The process according to claim 1 wherein said light cracked naphtha contains substantially all of the mercaptans and is subjected to a wet caustic wash process wherein the mercaptans contained therein are converted to sulfides and said sulfides are removed.

3. The process according to claim 1 wherein said intermediate cracked naphtha contains mercaptans and substantially all of the thiophenes and substantially all of said mercaptans and thiophenes are converted to hydrogen sulfide in said second hydrodesulfurization reactor.

4. The process according to claim 1 wherein said heavy cracked naphtha contains thiophenes and substantially all of said other organic sulfur compounds and a portion of said thiophenes and other organic sulfur compounds are converted to hydrogen sulfide in said first hydrodesulfurization reactor.

5. The process according to claim 4 wherein substantially all of the remaining thiophenes and other organic sulfur compounds are converted to hydrogen sulfide in said second hydrodesulfurization reactor.

6. The process according to claim 1 wherein said full boiling range cracked naphtha stream is first subjected to thioetherification in a thioetherification reactor prior to separating the full boiling range cracked naphtha stream into said three fractions, wherein substantially all of said mercaptans are reacted with a portion of said diolefins to form sulfides.

7. The process according to claim 6 wherein said sulfides are removed in said heavy cracked naphtha and substantially all of said sulfides are converted to hydrogen sulfide in said first hydrodesulfurization reactor.

8. The process according to claim 7 wherein the remaining sulfides are converted to hydrogen sulfide in said second hydrodesulfurization reactor.

9. The process according to claim 1 wherein said light cracked naphtha fraction boils in the range of C_5 to about 150° F., said intermediate cracked naphtha fraction boils in the range of about 150 to about 250° F. and said heavy cracked naphtha boils in the range of about 250 to 450° F.

10. A process for reducing the organic sulfur content of a full boiling range cracked naphtha stream containing olefins, diolefins, mercaptans, thiophenes, and other organic sulfur compounds, comprising the steps of:

- (a) subjecting the full boiling range naphtha to thioetherification in a thioetherification reactor wherein substantially all of said mercaptans are reacted with a portion of said diolefins to form sulfides;
- (b) separating the effluent from the thioetherification reactor into three fractions comprising a light cracked naphtha fraction boiling in the range of C_5 to about 150° F, an intermediate cracked naphtha fraction boiling in the range of about 150 to about 250° F. and a heavy cracked naphtha boiling in the range of about 250 to 450° F.;
- (b) subjecting the heaving cracked naphtha to hydrodesulfurization in a first hydrodesulfurization reactor containing a hydrodesulfurization catalyst; and
- (c) combining the effluent from the first hydrodesulfurization reactor with the intermediate cracked naphtha and subjecting the combined stream to hydrodesulfurization in a second hydrodesulfurization reactor.

11. A process for reducing the organic sulfur content of a full boiling range cracked naphtha stream containing olefins, diolefins, mercaptans, thiophenes, and other organic sulfur compounds, comprising the steps of:

- (a) separating the full boiling range cracked naphtha stream into three fractions comprising a light cracked naphtha fraction boiling in the range of C_5 to about 150° F., an intermediate cracked naphtha fraction boiling in the range of about 150 to about 250° F. and a heavy cracked naphtha boiling in the range of about 250 to 450° F.;

(b) subjecting the heaving cracked naphtha to hydrodesulfurization in a first hydrodesulfurization reactor containing a hydrodesulfurization catalyst;

(c) combining the effluent from the first hydrodesulfurization reactor with the intermediate cracked naphtha

and subjecting the combined stream to hydrodesulfurization in a second hydrodesulfurization reactor and
(d) subjecting said light cracked naphtha to a wet caustic wash wherein substantially all of the mercaptans contained therein are converted to sulfides.

* * * * *