



- (51) International Patent Classification:
A61F 13/38 (2006.01)
- (21) International Application Number:
PCT/US2016/028153
- (22) International Filing Date:
18 April 2016 (18.04.2016)
- (25) Filing Language: English
- (26) Publication Language: English
- (30) Priority Data:
62/149,142 17 April 2015 (17.04.2015) US
- (71) Applicant: INNOVAPREP LLC [US/US]; 132 East Main Street, Drexel, MO 64742 (US).

- (72) Inventors: ADOLPHSON, Alec, D.; 1507 Johnston Drive, Raymore, MO 64083 (US). PACKINGHAM, Ann, K.; 908 E 289th Street, Cleveland, MO 64734 (US). PAGE, Andrew, E.; 3165 Florence Road, Smithton, MO 65350 (US). ALBURTY, David, S.; 31712 Southfork Drive, Drexel, MO 64742 (US). PACKINGHAM, Zachary, A.; 6700 E 319th Street, Drexel, MO 64742 (US). BIRKENHOLZ, John, D.; 10000 N. Kentucky Avenue, Kansas City, MO 64157 (US). FISCHER, Michael, F.; 510 Graffway, Lee's Summit, MO 64081 (US).

- (74) Agent: MOAZZAM, Fariborz; Moazzam & Associates, LLC, 7601 Lewisville Road, Suite 304, McLean, VA 22102 (US).

- (81) Designated States (unless otherwise indicated, for every kind of national protection available): AE, AG, AL, AM, AO, AT, AU, AZ, BA, BB, BG, BH, BN, BR, BW, BY, BZ, CA, CH, CL, CN, CO, CR, CU, CZ, DE, DK, DM, DO, DZ, EC, EE, EG, ES, FI, GB, GD, GE, GH, GM, GT, HN, HR, HU, ID, IL, IN, IR, IS, JP, KE, KG, KN, KP, KR, KZ, LA, LC, LK, LR, LS, LU, LY, MA, MD, ME, MG, MK, MN, MW, MX, MY, MZ, NA, NG, NI, NO, NZ, OM, PA, PE, PG, PH, PL, PT, QA, RO, RS, RU, RW, SA, SC, SD, SE, SG, SK, SL, SM, ST, SV, SY, TH, TJ, TM, TN, TR, TT, TZ, UA, UG, US, UZ, VC, VN, ZA, ZM, ZW.

[Continued on next page]

(54) Title: DEVICES, SYSTEMS AND METHODS FOR SURFACE SAMPLING

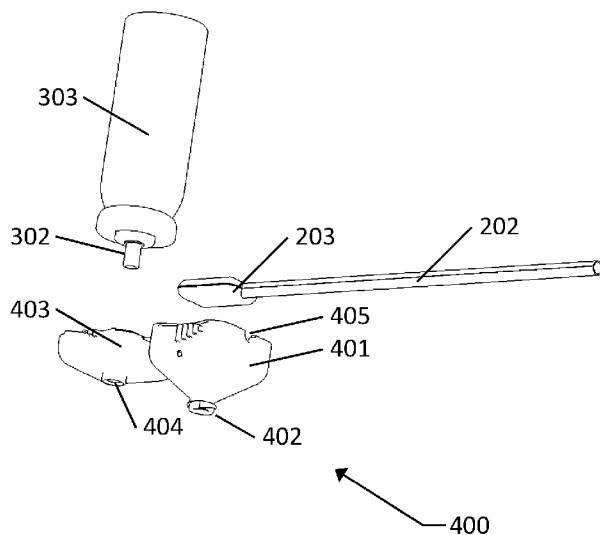

FIG. 6

(57) Abstract: Devices, systems and methods are disclosed which relate to using wet foam elution for removal of particles from swabs and wipes. This allow users to capture particles from surfaces and recover them by elution into small sample volumes for subsequent detection for human clinical, veterinary, food safety, pharmaceutical, outbreak investigations, forensics, biodefense and bioterrorism response, environmental monitoring, and other applications where collection of samples from surfaces and humans or animals is required. More specifically, the swabs or wipes are used to collect samples in the standard ways that commercially available swabs and wipes are in use today; from, for instance, food preparation surfaces in food plants, from production equipment in pharmaceutical facilities, for collection of dry powders during bioterrorism event response, and for collection of clinical samples such as nasal, throat, nasopharyngeal, and wounds.



- (84) Designated States** (*unless otherwise indicated, for every kind of regional protection available*): ARIPO (BW, GH, GM, KE, LR, LS, MW, MZ, NA, RW, SD, SL, ST, SZ, TZ, UG, ZM, ZW), Eurasian (AM, AZ, BY, KG, KZ, RU, TJ, TM), European (AL, AT, BE, BG, CH, CY, CZ, DE, DK, EE, ES, FI, FR, GB, GR, HR, HU, IE, IS, IT, LT, LU, LV, MC, MK, MT, NL, NO, PL, PT, RO, RS, SE, SI, SK, SM, TR), OAPI (BF, BJ, CF, CG, CI, CM, GA, GN, GQ, GW, KM, ML, MR, NE, SN, TD, TG).
- Published:**
- *with international search report (Art. 21(3))*
 - *before the expiration of the time limit for amending the claims and to be republished in the event of receipt of amendments (Rule 48.2(h))*

DEVICES, SYSTEMS AND METHODS FOR SURFACE SAMPLING

[0001] This application claims priority to U.S. Provisional Patent Application Serial No. 62/149,142, filed on April 17, 2015, the contents of which are hereby incorporated by reference herein in their entirety into this disclosure.

TECHNICAL FIELD

[0002] The present subject disclosure relates generally to the fields of human clinical, veterinary, food safety, pharmaceutical, outbreak investigations, forensics, biodefense and bioterrorism response, environmental monitoring, and other applications where collection of samples from surfaces and humans or animals is required. Swab and wipe sampling are routinely used in these and other fields to collect surface samples, human clinical, animal clinical and other sample types. More specifically, the present subject disclosure comprises systems, devices and methods for recovery of samples from swabs and wipes using a wet foam elution process.

BACKGROUND OF THE SUBJECT DISCLOSURE

[0003] A wide range of existing, and developing, rapid analysis platforms are potentially useful technologies for detection and identification needs. Detection and identification may key on whole organisms, nucleic acids, or proteins. Culture based analysis, antibiotic susceptibility testing, and functional assays all require live organism samples. Common nucleic acid techniques include qPCR, UHTS, and hybridization arrays. ELISA and other immunoassay techniques, mass spectrometry, chromatography techniques,

and other techniques may be used for protein analysis. There are significant reasons in some cases to choose one of these techniques over the other or in some cases to analyze with more than one technique. The various systems and methods are powerful techniques for rapidly detecting and identifying pathogens and other microorganisms and biological particles, but they require good techniques and devices for efficiently delivering high-quality samples, and contained target organism in a small sample volume.

[0004] Swabs and wipes are routinely used as tools for collection of biological and non-biological materials from environmental and clinical samples. Samples are collected by swabbing or wiping an appropriate surface. The sample must then be recovered from the collection tool into a liquid buffer or in some cases directly onto a culture plate for biological samples. A number of methods exist for recovery of samples from swabs and wipes, but these methods are inefficient and often recover the samples into relatively large liquid volumes. Poor recoveries and large sample volumes result in samples that are often too dilute to allow for rapid detection. Further, it is desirable to be able to perform sample recovery in a field setting with minimal equipment and minimal user steps, but conventional methods frequently require a significant number of steps and a laboratory setting where vortexers, centrifuges, or other AC powered laboratory equipment are available.

SUMMARY OF THE SUBJECT DISCLOSURE

[0005] Novel, rapid and efficient swab and wipe elution systems, devices and methods are disclosed that allow users to capture and elute swab and wipe samples for human clinical, veterinary, food safety, pharmaceutical, outbreak

investigations, forensics, biodefense and bioterrorism response, environmental monitoring, and other applications where collection of samples from surfaces and humans or animals is required. More specifically, the swabs and wipes are used to collect samples in the standard ways that are used today; from, for instance, food preparation surfaces in food plants, from production equipment in pharmaceutical facilities, for collection of dry powders, dry spill residues, or liquid spills during bioterrorism event response, and for collection of human and animal clinical samples such as nasal, throat, nasopharyngeal, and wounds.

[0006] After sample collection, various elution techniques may be used to elute target materials from swabs, including, for example, (1) elution down the lumen of the hollow shaft of a swab with the foam traveling from the inside to the outside of the swab and (2) enclosure of the swab in an elution chamber with the foam traveling across the outside surface of the swab head. Performing the elution in either of these two ways allows for the elution to be quickly and efficiently performed while using elution volumes significantly smaller than used in the traditional swab elution methods.

[0007] The present subject disclosure presents swab collection and elution devices that improve work flow for field and laboratory collection and elution of swab samples. In the case of hollow shaft swabs, the user pushes the swab onto the swab collection/elution instrument, and the swab can then be used in a dry state, or pre-wetted using the onboard wet foam. The present system provides a convenient tool for securely holding the swab during sample collection. After sample collection, the swab head is held inside an appropriate sample container and an elution button or lever is actuated,

releasing elution foam through the swab head and into the sample container.

The swab can then be automatically ejected into a waste container.

[0008] In another disclosed technique, a swab with or without a hollow shaft is used to collect a sample in the conventional way, and then the user inserts the swab head into the elution cartridge. The cartridge either seals around the swab shaft or the shaft is broken at a pre-scored line or an integral cutter is used to cut off the shaft and the cartridge seals the opening where the shaft previously was. The cartridge is then inserted into an elution system or an elution dispenser is pushed onto the cartridge and wet foam is dispensed into the hollow shaft or across the outside surface of the swab head. The foam elutes the collected target materials and is deposited into a sample reservoir within the cartridge. The collected sample can then be manually removed with a syringe or pipette device or automatically drawn from the reservoir into an assay portion of the cartridge or into a separate assay cartridge.

[0009] In addition to swabs, surface wipes and blotting devices are used for a variety of environmental surface and clinical specimen collections. Using similar wet foam elution processes to those described for swabs, these devices can also be eluted.

[0010] Swabs and wipes come in a variety of sizes, shapes and materials. The wet foam elution process described in Applicant's prior and co-pending patents and patent applications provide for an efficient technique for eluting particles from membrane filters, depth filters and similar fibrous and sponge-type materials that can also be used for collection from surfaces and clinical specimens. The following Applicant patents and pending applications are incorporated by reference herein in their entirety into this disclosure and

disclose various elution methodologies, but none present the novel techniques of sample collection by swab or wipe as disclosed in the present subject matter: USPN 8,110,112; USPN 8,584,535 (“Applicant’s Concentrating Pipette Instrument”); USPN 8,584,536; USPN 8,677,839; USPN 8,677,840; USPN 8,726,744; USPN 8,758,623; US Pat. App. 14/058,193; US Pat. App. 14/191,205; US Pat. App. 14/313,618.

BRIEF DESCRIPTION OF THE DRAWINGS

[0011] The accompanying drawings, which are incorporated in and constitute a part of this specification, illustrate embodiments of the subject disclosure and technical data supporting those embodiments, and together with the written description, serve to explain certain principles of the subject disclosure.

[0012] FIG. 1 shows the direction of wet foam elution flow down the hollow shaft and out through the swab head of a hollow-shaft swab, according to an exemplary embodiment of the present subject disclosure.

[0013] FIG. 2 shows a configuration of a hollow-shaft swab with holes through the side wall of the shaft tube to allow flow of foam through the entire swab head, according to an exemplary embodiment of the present subject disclosure.

[0014] FIG. 3 shows the direction of wet foam elution flow across head of a swab, according to an exemplary embodiment of the present subject disclosure.

[0015] FIGS. 4 and 5 show a device for enabling surface collection and subsequent wet foam elution down the hollow shaft and out through the swab

head for recovery of particles using hollow-shaft swabs, according to an exemplary embodiment of the present subject disclosure.

[0016] FIGS. 6-9 show a device for wet foam elution across the head of a swab for recovery of particles using swabs, according to an exemplary embodiment of the present subject disclosure.

[0017] FIG. 10 shows a hand-held wet foam elution canister with an internal pouch for delivering a set volume of elution fluid, according to an exemplary embodiment of the present subject disclosure.

[0018] FIGS. 11 and 12 show a consumable for hollow shaft swab elution using wet foam dispensed from Applicant's Concentrating Pipette Instrument, according to an exemplary embodiment of the present subject disclosure.

[0019] FIGS. 13 and 14 show a consumable for swab elution performed by a flow of foam across the swab head using wet foam dispensed from Applicant's Concentrating Pipette Instrument, according to an exemplary embodiment of the present subject disclosure.

[0020] FIGS. 15 and 16 show another configuration of a consumable for swab elution performed by a flow of foam across the swab head using wet foam dispensed from Applicant's Concentrating Pipette Instrument, according to an exemplary embodiment of the present subject disclosure.

[0021] FIGS. 17-25 show a consumable surface wipe and elution device and various components with a thin wipe material and a vented sample cup for catching the elution fluid, according to an exemplary embodiment of the present subject disclosure.

[0022] FIGS. 26-28 show a consumable surface wipe and elution device with a flexible bag for catching the elution fluid and delivering a sample aliquot, according to an exemplary embodiment of the present subject disclosure.

[0023] FIGS. 29 and 30 show an alternate configuration of a consumable surface wipe and elution device with a thick wipe material that is crushed around the edge to seal the material during the elution process, and a vented sample cup for catching the elution fluid, according to an exemplary embodiment of the present subject disclosure.

[0024] FIGS. 31 and 32 show an alternate configuration of a consumable surface wipe and elution device with a thick wipe material that is compressed and bonded at the edge to seal the material during the elution process, and a vented sample cup for catching the elution fluid, according to an exemplary embodiment of the present subject disclosure.

[0025] FIGS. 33 and 34 show an alternate configuration of a consumable surface wipe and elution device and various components with a thin wipe material and a vented sample cup for catching the elution fluid wherein the elution is performed by a flow of foam across the swab head using wet foam dispensed from Applicant's Concentrating Pipette Instrument, according to an exemplary embodiment of the present subject disclosure.

DETAILED DESCRIPTION OF THE SUBJECT DISCLOSURE

[0026] The following detailed description references specific embodiments of the subject disclosure and accompanying figures, including the respective best modes for carrying out each embodiment. It shall be understood that these illustrations are by way of example and not by way of limitation.

[0027] A detailed description of the disclosed swab and wipe elution techniques is provided below including a detailed description of the wet foam elution method and drawings of the disclosed devices.

[0028] *Wet Foam Elution*

[0029] Wet foam elution is a novel method for recovery of particles from filters, swabs, wipes and other surfaces. High-quality foam is produced by rapidly dispensing an elution solution containing a surfactant or other foaming agent from a high-pressure liquid-soluble gas atmosphere through a capillary, or other means of agitation, and into an expansion zone. The foam is then swept or across the material or surface to be extracted or eluted. Surfactants including Tween 20, Tween 80, Triton X-100, sodium dodecyl sulfate, and other ionic, nonionic, cationic and zwitterionic surfactants or proteins may be used as foaming agents. A range of other buffers may be added to maintain the elution fluid pH in a specific range or to supplement the fluid in other ways, such as maintain a specific ionic strength. Carbon dioxide and nitrous oxide are highly soluble in water under pressure and therefor work well as expansion gases. Other gases, such as nitrogen, may also be used alone or in combination with other gases to provide desired characteristics to the elution foam.

[0030] Foam has unique properties that make it a superior method for elution of particles from various materials and surfaces. Elution with aqueous foam has significant advantages over elution with standard aqueous solutions. Possibly the most important aspect of using foam for elution is the advantage gained by expanding the fluid to many times its original volume. Because most of the fluid simply goes toward filling the void volume of the inside of the

swab or around the surface, rather than performing the actual elution at the surface, it is difficult to efficiently elute particles while keeping the elution volume small – and keeping the volume small is critical to keeping the target concentration in the eluted sample high. During wet foam elution, the liquid is expanded five or more times its original volume.

[0031] Foams are frequently used during tertiary extraction for enhanced oil recovery. Due to the high viscosity of foams, they exhibit reduced channeling thereby sweeping more oil out of porous media. This same characteristic makes foam ideal for extraction from complex materials and surfaces. One application that the ability of wet foam elution to improve elution efficiencies has been proven is in the use of hollow fiber membrane filter concentration modules for concentration of bacteria and viruses. It is well known that channeling or non-uniform flow distribution takes place in hollow fiber membrane filter modules that contain multiple fibers. Channeling is dependent on inlet manifold design, Reynolds number, pressure drop and other issues such as irregularity in fiber diameter. In short, channeling is difficult to control and is almost certainly at play during recovery of organisms from multiple fiber concentration units with aqueous extraction fluids.

[0032] Several research teams have recently studied this subject and determined that uniform foams in a capillary exhibit plug flow and self-lubricate with a very narrow lubricating layer thickness on the order of 10 μm or less. The foam moves as a rigid body lubricated by water generated by breaking foam at the wall. Because core flow is absent and the lubricating layer is thin, the foam is able to act with high shear in the fiber surface boundary layer to sweep away the captured particles. Furthermore, energy

created by breaking bubbles may enhance particle removal from the hollow fiber surface and other surfaces or materials. The majority of the carbon dioxide bubbles in the wet foam burst soon after release into a lower pressure environment (e.g., atmospheric or near atmospheric), returning the foam to a liquid and allowing for transfer to the identifier as an aqueous sample. Most of the foam returns to a free liquid within two seconds.

[0033] *Swab Collection/Elution*

[0034] This disclosure presents various methods of wet foam elution of swabs. Two of the examples presented include (A) flow down the lumen of a hollow shaft swab and out through the swab head material, and (B) flow of foam across the swab head.

[0035] FIG. 1 shows the direction of flow during elution of a hollow shaft swab. Following collection of a sample with the hollow shaft swab **100**, wet foam is introduced into the opening **101** of a hollow shaft **102**. Following release, the wet foam travels down the lumen of the hollow shaft **102** and is pushed out through the swab head **103** and into a sample container **104**. In the process particles that were earlier collected onto the swab head surface are now recovered into a small volume of foam, which breaks down into a small liquid sample. Various types of swabs may be used in this technique, including a standard hollow shaft swab, such as Puritan Medical's Standard 6" Polyester Swab with plastic handle (part #806-PD).

[0036] FIG. 2 shows a custom designed hollow shaft swab **100** with a lumen **106** and holes **107** in the shaft wall **105** under the swab head **103**. The holes **107** in the walls **105** of the shaft allow foam to more uniformly flow out through the entire swab head surface and therefor provide more complete elution of

the entire swab head. The end of the shaft, under the swab head **103**, may be open, completely sealed off or partially closed off to provide as uniform of flow throughout the entire swab head surface as possible. Additionally, the holes **107** may consist of one or more holes in the shaft wall **105** or may consist of a porous section of shaft produced by various manufacturing methods.

[0037] Elution of hollow swabs may be conducted in any direction with respect to foam flow. In one exemplary embodiment shown in FIG. 3, the direction of flow during elution across the outside surface of a swab head **203** of a swab **200** into a sample container **104** is generally perpendicular to the longitudinal axis of the shaft **202**.

[0038] FIGS. 4 and 5 show a hollow shaft swab collection and elution tool **300** in conjunction with a hollow shaft swab **100**. The collection and elution tool **300** holds a pressurized elution fluid canister **303**, containing a wet foam elution solution under a pressurized soluble gas atmosphere, in the canister cradle **306** and in communication with the canister valve actuator **305**. The pressurized elution fluid canister **303** may be a standard continuous release valve or a standard metered dose release valve. A hollow shaft swab **100** is attached to the valve stem **302** of the elution fluid canister **303** with the swab fitting **301**. A user first uses the tool **300** to hold the swab **100** during sample collection. During the sample collection process the user may wet the swab head **103** by actuating the tool dispensing lever **304** to cause the canister valve actuator to push down on the elution fluid canister valve stem **302**, thereby releasing elution fluid which travels down the lumen of the swab hollow shaft **102** and out through the swab head **102**. This gives the user the

capability of easily using the swab **100** in a dry or wet state.

[0039] In use, and following a sample collection, the tool **300** is then used to hold the swab head **103** in a sample container **104** and the user then actuates the dispensing lever **304** to release elution fluid in the form of a wet foam, which travels down the lumen of the swab hollow shaft **101** and out through the swab head **102**. In the process particles that were earlier collected onto the swab head surface **103** are now recovered into a small volume of foam, which breaks down into a small liquid sample.

[0040] In alternative embodiments of the hollow shaft swab collection and elution tool 300, an integral swab ejector button or lever may be added to allow the user, following swab elution, to easily eject the used swab into a waste container. In another exemplary embodiment, the tool 300 may include a mechanism for allowing the user to push the tool onto a new swab while holding only the tool, much like commercially available micro-pipettors, such as those produced and sold by Eppendorf, which are held while pushing them onto a pipette tip contained in a pipette tip box. One example of a micro-pipettor of this type is the Eppendorf family of pipettors. In this embodiment the operation will be familiar to those familiar with micro-pipettors that allow a user to push a pipette tip onto the instrument, then use the pipettor and pipette to acquire a set sample volume, prior to ejecting the used pipette into a waste container. In such an embodiment of the hollow shaft swab collection and elution tool, a user would push the tool onto the swab, actuate the foam lever or button to wet the swab head, collect a surface sample, hold the swab head in a sample container, actuate the foam lever or button to elute the sample into the container, hold the swab over a waste container and actuate

the swab ejector button or lever to release the used swab into the waste container.

[0041] In another alternative embodiment of the hollow shaft swab collection and elution tool **300**, the system may contain mechanical or electro-mechanical mechanism of releasing a small set volume of elution fluid from the pressurized elution fluid canister **303**. This can be performed with mechanical based systems such as an integral sample reservoir or sample loop that holds a set volume of elution fluid after release from the aerosol canister and then releases this set volume during the elution process. Alternatively the system may use a standard electromechanical valve, such as those manufactured by Bio-Chem Fluidics Inc., to release a set volume during the elution process. In this case the foam is released by opening the valve for a defined period of time so that a reproducible volume of the elution fluid is released through an integral control orifice.

[0042] The hollow shaft swabs used in these systems may be especially configured to improve the elution process. This may include use of different swab materials, such as flocked materials, that improve elution and have the correct pressure drop to allow the wet foam through, but allow the foam to flow more evenly through the entire swab head surface area. Additionally, the hollow shaft **102** may be configured with a porous area or specifically sized holes under the swab head **103** material that allow the foam to be evenly released throughout the collect zone of the swab head. A hole at the end of the swab shaft may be included to allow foam to contact the end of the swab. This hole may be the same size or smaller than the shaft lumen.

[0043] Testing of a prototype hollow shaft swab collection and elution tool **300**

prototype was performed with 3.0 μm nominal diameter yellow-green fluorescent polystyrene microspheres spiked onto a melamine resin-coated Masonite coupon and allowed to dry. The microspheres were swabbed from the surface, using a standard swabbing approach while holding the swab in the collection and elution tool **300**, and then recovered into a small volume of elution fluid using the prototype tool. A UV light was then placed over the tubes to make the captured microspheres more visible. From this simple test it was clear that the swab sample contained significant quantities of microspheres collected from the surface.

[0044] FIGS. 6 – 9 show an exemplary embodiment of a cartridge type swab elution device **400** which uses a flow of foam across the face of the swab head **203** to elute. The user first swabs a target surface and then places the swab into the clam-shell cartridge **401**. The cartridge **401** contains a living hinge **408** on one side and sealing surfaces **409** around the elution chamber **406**. The user closes the clam-shell cartridge **401** until it is latched and sealed. Aperture **405** is designed to accommodate the shaft **202** while the clam-shell cartridge **401** is closed. The user then attaches the luer adapter **402** to a separate sample container or assay cartridge, or holds the cartridge over a sample tube. The valve stem **302** of a pressurized elution fluid canister **303**, with a metering valve, as is commonly available, is then pushed into the top port **404** located on a top lid portion **403** of the cartridge, releasing a set volume of elution fluid. The elution fluid quickly expands into a larger volume of wet foam, and under the pressure created by the propellant gas coming out of solution, is forced to flow over and around the swab head **203**. The foam then flows into a foam collapsing reservoir **407** below the swab head **203** and

out into a sample container or secondary cartridge.

[0045] Many alternate embodiments of the cartridge type swab elution device can be envisioned by one skilled in the art. In one embodiment the elution fluid can be held in the foam collapsing reservoir **407** until needed, at which time it is drawn out and into a secondary assay cartridge or sample reservoir. In another embodiment, a similar cartridge can be built that would be eluted by insertion of the cartridge into an elution instrument that contains a larger elution fluid canister and a timed valve to allow for precise control of the elution fluid volume released. In another embodiment, the cartridge could be part of a larger assay cartridge containing the elution system, other sample preparation operations and the assay components. In this way after sampling the user could place the swab into a cartridge which would be inserted into an instrument. The instrument would then run through the elution process, sample preparation steps and assay steps. The target materials would remain within the cartridge throughout the process.

[0046] In another embodiment, the cartridge may be used for elution of hollow shaft swabs. The user would then use a hollow swab shaft, an integrated cutting blade to cut the swab shaft, and a mechanism for fluidically connecting the pressurized foam canister to the lumen of the hollow swab shaft that would allow elution foam to be introduced into the shaft lumen and then out through the swab head.

[0047] Many other embodiments of the swab elution devices and methods can be envisioned including the use of dual swabs (two swabs connected together) for collection of duplicate samples or samples from both nares of a single patient at the same time for instance. Additionally many different sizes,

shapes and configurations of swabs, including different material types, may be used - including very large and very small swabs. Different shaped swabs may also be used including scoop shaped or spiral shaped for improved collection in certain applications.

[0048] FIG. 10 shows an exemplary embodiment of a novel pouch-on-valve aerosol canister **500** which provides a mechanism of delivering a small set volume from the portable pressurized elution fluid canister **30**, described throughout this disclosure. The aerosol canister **500** includes a standard continuous release aerosol valve **501** and a standard valve stem **302**. Enclosed within the canister **303** and attached to the base of the valve **501** and enclosing the valve inlet **502** to create fluid reservoir **504** is a silicone rubber or other flexible material pouch or bag **503**. To fill pouch-on-valve aerosol canisters **500** during manufacture, pressurized gas is pushed into the valve stem **302**, through the valve **501**, into the reservoir **504** and through the orifice **505** and finally into the canister **303**, until a set pressure is reached. Upon reaching the set pressure, fluid saturated with the propellant gas is pushed through the valve **302** and into the reservoir **504** until a set volume of fluid has been pushed in. The volume of fluid pushed in is such that reservoir **504** is overfilled, such that any additional fluid passes through orifice **505** into canister **303**. During use, valve stem **302** is depressed and held in a depressed position until flow of liquid and gas stops. When valve stem **302** is depressed fluid flows quickly from reservoir **504** out through valve **501** and is dispensed from valve stem **302**. When the volume of fluid contained in reservoir **504** has been dispensed the flexible reservoir **504** becomes compressed due to the higher pressure of gas in the canister **303**.

Compression of the reservoir **504** causes it to act like a check valve and stop flow of gas from the aerosol canister **500**.

[0049] FIGS. 11 and 12 show an exemplary embodiment of a hollow shaft swab elution device **604** for use with Applicant's Concentrating Pipette System **600**. Hollow shaft swab **100** is attached to the elution device **604** by connecting fitting **108** to fitting **606**. The swab **100** may be used prior to connecting it to the elution device **604** or the two may be connected and packaged for use together. After collection of a surface sample, the two nipples **608** and **609** on the fitting **605** are inserted into the Concentrating Pipette **600** head **602**. After insertion, the user interface **603** is used to set the elution fluid setpoints to allow the appropriate volume of elution fluid to be dispensed and an elution is performed. Elution fluid is released by an electromechanical elution fluid valve within the Concentrating Pipette **600** from the pressurized elution fluid canister **601**. Elution fluid is released in the form of wet foam and travels through elution fluid nipple **608**, fittings **606** and **108** and through the lumen 106 of the hollow shaft **102** and out through shaft holes **107** and the swab head **103**. As the foam flows out through the swab head **103** captured particles are recovered into the foam and dispensed into the reservoir **607**.

[0050] FIGS. 13 and 14 show an exemplary embodiment of an across the head swab elution device **610** for use with the Applicant's Concentrating Pipette System **600**. After collection of a sample with swab **200**, the shaft **202** of the swab **200** is placed through star-ring **613** and into fitting **615** and dropped into place such that swab head **203** is within chamber **614** in fitting **611**. Fitting **612** is then screwed into fitting **611**. This assembly allows the

swab head **203** to rest against star-ring **613** and in the center of chamber **614**. Star-ring **613** keeps the swab head **203** from being pushed into the flow path below chamber **614** during the elution process and allows wet foam to flow around all sides of the swab head **203**. Fitting **612** is then attached to fitting **606** and the two nipples **608** and **609** on the fitting **605** are inserted into the head **602** on Concentrating Pipette System **600**. After insertion, the user interface **603** is used to set the elution fluid setpoints to allow the appropriate volume of elution fluid to be dispensed and an elution is performed. Elution fluid is released by an electromechanical elution fluid valve within the Concentrating Pipette System **600** from the pressurized elution fluid canister **601**. Elution fluid is released in the form of wet foam and travels through the internal flow path of nipple **608**, fitting **605**, fitting **612**, past swab head **203**, past star-ring **613** and out through the flow path of fittings **611** and **615**. The captured particles are recovered into the foam and dispensed into the reservoir **607**.

[0051] FIGS. 15 and 16 show an exemplary embodiment of use of the across the head swab elution device **400** (shown in FIGS. 6-9) with Applicant's Concentrating Pipette System **600** performing elution rather than a stand-alone pressurized elution fluid canister. The user first swabs the surface and then places the swab into the clam-shell cartridge **401**. The cartridge contains a living hinge **408** on one side and sealing surfaces **409** around the elution chamber **406**. The users close the clam-shell cartridge until it is latched and sealed. Fitting **404** is then attached to fitting **606** and the two nipples **608** and **609** on the fitting **605** are inserted into the head **602** of the Concentrating Pipette System **600**. After insertion, the user interface **603** is used to set the

elution fluid setpoints to allow the appropriate volume of elution fluid to be dispensed and an elution is performed. Elution fluid is released by an electromechanical elution fluid valve within the Concentrating Pipette System **600** from the pressurized elution fluid canister **601**. Elution fluid is released in the form of wet foam and travels through the internal flow path of nipple **608**, fitting **606**, fitting **404**, and is forced to flow over and around the swab head **203** within chamber **406**. The foam then flows into a foam collapsing reservoir **407** and the captured particles are recovered into the foam and it is dispensed into a sample container **104**.

[0052] *Wipe Collection/Elution*

[0053] FIGS. 17 through 25 show an exemplary embodiment of a surface wipe collection and recovery device **700**. Surface wipe material **707** is a non-woven, woven or open cell foam material with support **706** and attachment post **705**. For collection of surface samples, a user holds onto attachment post **705** and support **706**, or attaches attachment post **705** to elutor cap **701** and uses elutor cap **701** as a handle. A surface sample is then collected with the dry surface wipe material **707** or pre-wets the material or the surface with water, surfactant solution or other appropriate buffer solution. The surface sample is collected from an appropriate area and the attachment post **705** is attached to elutor cap **701** (if not already attached). Elutor cap **701** and wipe material **707** are then inserted into elutor ring **708** and snapped into place with snap fit **712**. When snapped into place, wipe material **707** becomes compressed as shown as **711** between elutor cap **701** and elutor ring **708**, as seen in FIG. 25. The combination of the attachment post **705**, support material **706** and wipe material **707** are flexible so that once locked into

position, the original flat geometry flares into a convex geometry, as shown in FIGS. 24 and 25. Compression of the wipe material **707** acts to keep elution foam from passing around the edge of the wipe material during the sample recovery process. The elutor ring **708** is then attached to sample cup **710**. The hand-held pressurized elution fluid canister **303** is then placed into fitting **702** and the user pushes down on the canister **303** to actuate valve stem **302** against valve stem port **703**. Upon actuation, the valve stem **302** releases elution fluid which passes through flow splitter **704**. Flow splitter **704** acts to push the elution fluid, which is rapidly turned into wet foam away from the center flow path, so that it distributes evenly as it flows down and through the wipe material **707**, recovering particles that were captured from the surface into the material. The foam is then dispensed into sample cup **710** and quickly breaks back down into a liquid sample. Gas vents **709** allow gas released from the wet foam to escape from the assembly, so that the entire assembly remains at or near to atmospheric pressure.

[0054] FIGS 26 through 28 show an exemplary embodiment of a surface wipe collection and recovery device **800**. Surface wipe material **707** is a non-woven, woven or open cell foam material with support **706** and attachment post **705**. For collection of surface samples, a user holds onto attachment post **705** and support **706**, or attaches attachment post **705** to elutor cap **701** and uses elutor cap **701** as a handle. A surface sample is then collected with the dry surface wipe material **707**, or pre-wets the material or the surface with water, surfactant solution or other appropriate buffer solution. The surface sample is collected from an appropriate area and the attachment post is attached to elutor cap **701** (if not already attached). Elutor cap **701** and wipe

material **707** are then inserted into elutor ring **708** and snapped into place with snap fit **712**. When snapped into place, wipe material **707** becomes compressed as shown in **711** between elutor cap **701** and elutor ring **708**. Compression of the wipe material **707** acts to keep elution foam from passing around the edge of the wipe material during the sample recovery process. The elutor ring **708** is then attached to sample bag adapter **802** with the two pieces sealed together at seal **801**. The hand-held pressurized elution fluid canister **303** is then placed into fitting **702** and the user pushes down on the canister **303** to actuate valve stem **302** against valve stem port **703**. Upon actuation, the valve stem **302** releases elution fluid which passes through flow splitter **704**. Flow splitter **704** acts to push the elution fluid, which is rapidly turned into wet foam, away from the center flow path, so that it distributes evenly as it flows down and through the wipe material **707**, recovering particles that were captured from the surface into the material. The foam is then dispensed through flat tube check valve **804** and into sample bag **803** and quickly breaks back down into a liquid sample. Because the bag **803** is flat and the system does not contain vents the bag **803** is inflated slightly as the wet foam is dispensed into the bag. Pinch valve **805** is then opened, if not already open, and the bag **803** is squeezed slightly to push fluid into the sample aliquot reservoir **806**. The sample aliquot reservoir **806** can be custom configured to hold a set volume of sample for dispensing to assay cartridges or sample reservoirs. Pressure is then released from the bag **803** and the pinch valve **805** is closed. The user then attaches self-opening luer lock **807** to a separate assay cartridge or sample container and squeezes sample aliquot reservoir **806** to dispense the measured sample.

[0055] FIGS. 29 and 30 show an exemplary embodiment of surface wipe collection and recovery device **900**. Surface wipe material **901** is a hydrophilic open cell foam material. For collection of surface samples, the elutor cap **701** is used as a handle. A surface sample is then collected with the dry surface wipe material **901**, or the user pre-wets the material or the surface with water, surfactant solution or other appropriate buffer solution. The surface sample is collected from an appropriate area and the elutor cap **701** is inserted into elutor ring **708** and snapped into place with snap fit **712**. When snapped into place, wipe material **901** becomes compressed as shown in **902** between elutor cap **701** and elutor ring **708**. Compression of the wipe material **901** acts to keep elution foam from passing around the edge of the wipe material during the sample recovery process. The elutor ring **708** is then attached to sample cup **710**. The hand-held pressurized elution fluid canister **303** is then placed into fitting **702** and the user pushes down on the canister **303** to actuate valve stem **302** against valve stem port **703**. Upon actuation, the valve stem **302** releases elution fluid which passes through flow splitter **704**. Flow splitter **704** acts to push the elution fluid, which is rapidly turned into wet foam away from the center flow path, so that it distributes evenly as it flows down and through the wipe material **901**, recovering particles that were captured from the surface into the material. The foam is then dispensed into sample cup **710** and quickly breaks back down into a liquid sample. Gas vents **709** allow gas released from the wet foam to escape from the assembly, so that the entire assembly remains at or near to atmospheric pressure.

[0056] FIGS 31 and 32 show an exemplary embodiment of a surface wipe collection and recovery device **1000**. Surface wipe material **1002** is a

hydrophilic open cell foam material. For collection of surface samples, the elutor cap/swab handle **1001** is used as a handle. The wipe material **1002** is bonded to the elutor cap/swab handle **1001** along surface **1004**. The wipe material **1002** is cut slightly larger than the opening to ensure some compression of the wipe material and to reduce passage of foam along the bonding joint **1004**. The bonding joint **1004** is also long enough so that the foam flow path is the same at the bond location as at other locations in the wipe material. A surface sample is then collected with the dry surface wipe material **1002**, or the user pre-wets the material or the surface with water, surfactant solution or other appropriate buffer solution. The surface sample is collected from an appropriate area and the elutor cap/swab handle **1001** is snapped onto sample cup **710**. The hand-held pressurized elution fluid canister **303** is then placed into fitting **702** and the user pushes down on the canister **303** to actuate valve stem **302** against valve stem port **703**. Upon actuation, the valve stem **302** releases elution fluid which passes through flow splitter **704**. Flow splitter **704** acts to push the elution fluid, which is rapidly turned into a wet foam away from the center flow path, so that it distributes evenly as it flows down and through the wipe material **1002**, recovering particles that were captured from the surface into the material. The foam is then dispensed into sample cup **710** and quickly breaks back down into a liquid sample. Gas vents **1003** allow gas released from the wet foam to escape from the assembly, so that the entire assembly remains at or near to atmospheric pressure.

[0057] FIGS. 33 and 34 show an exemplary embodiment of a surface wipe collection and recovery device **700** for use with Applicant's Concentrating

Pipette System **600**. After collection of a surface sample with surface wipe material **707**, the two nipples **1101** and **1102** on the fitting **1100** are inserted into the Concentrating Pipette **600** head **602**. After insertion, the user interface **603** is used to set the elution fluid setpoints to allow the appropriate volume of elution fluid to be dispensed and an elution is performed. Elution fluid is released by an electromechanical elution fluid valve within the Concentrating Pipette **600** from the pressurized elution fluid canister **601**. Elution fluid is released in the form of wet foam which passes through elution fluid nipple **1101**, fittings **1100** and flow splitter **704**. Flow splitter **704** acts to push the elution fluid, which is rapidly turned into wet foam away from the center flow path, so that it distributes evenly as it flows down and through the wipe material **707**, recovering particles that were captured from the surface into the material. The foam is then dispensed into sample cup **710** and quickly breaks back down into a liquid sample. Gas vents **709** allow gas released from the wet foam to escape from the assembly, so that the entire assembly remains at or near to atmospheric pressure.

[0058] It is desirable to be able to efficiently collect and elute dry deposited and wet deposited and then dried materials, and also to be able to absorb still wet materials and to be able to captured powder type materials. As would be apparent to a person skilled in the art, a number of types of materials may be used as the collection material in the disclosed systems. Hydrophilic surface sampling materials are desired for collection of dried-on material, liquid samples, and powders from smooth surfaces. These may include materials such as flocked materials, rayon, cellulose and cotton materials and many others that will be apparent to someone skilled in the art. Electret surface

sampling materials, flocked materials and other hydrophobic or hydrophilic materials may be used for collection of dry, aerosol deposited materials or dry, dispersed powders from smooth surfaces. Sponge materials and durable wipe materials with thick fibrous surfaces may be used for collection from rougher and abrasive surfaces.

[0059] It will be appreciated that the foregoing instrumentalities teach by way of example, and not by limitation. Accordingly, those skilled in the art understand that the subject matter is not limited to what is strictly disclosed, but also pertains to what is understood by those skilled in the art on the basis of the teachings herein. The inventors hereby state their subject matter to rely, as may be needed, upon the Doctrine of Equivalents to protect the fullness of their rights in what is claimed.

WHAT IS CLAIMED IS:

1. A portable system for collecting and extracting a sample from a surface, the system comprising:

a swab having a head at one end of an extended shaft, the extended shaft having a lumen that extends substantially throughout the length of the shaft;

a source of pressurized wet foam;

wherein as the source of pressurized foam is introduced at an opposite end of the extended shaft with respect to the head, the wet foam travels through the lumen and elutes samples from the surface of the swab head.

2. The system in claim 1, wherein the source of wet foam is a portable canister.

3. The system in claim 2, wherein the canister is activated by a wet foam dispensing lever.

4. The system in claim 1, wherein the source of wet foam is a separate elution system.

5. The system in claim 1, wherein the extended shaft includes apertures near the head to allow for uniform distribution of wet foam through the head and onto its exterior surface.

6. The system in claim 1, further comprising a collection receptacle for collecting the wet foam with sample after elution from the swab head.
7. A portable system for collecting and extracting a sample from a surface, the system comprising:
 - a swab having a head at one end of an extended shaft;
 - a source of pressurized wet foam;
 - a clam-shell cartridge which accommodates the swab head such that the swab head is substantially sealed within a chamber inside the closed cartridge;
 - wherein as the source of pressurized foam is introduced into the cartridge, the wet foam elutes samples from the surface of the swab head.
8. The system in claim 7, wherein the cartridge has a hinge opposite of where the extended shaft of the swab extends therein.
9. The system in claim 8, wherein the cartridge has an accommodating aperture adapted to retain the extended shaft of the swab.
10. The system in claim 9, wherein the cartridge further comprises a collapsing reservoir distal to where the wet foam elutes samples from the surface of the swab head.
11. The system in claim 7, wherein the source of wet foam is a portable canister.

12. The system in claim 7, wherein the source of wet foam is a separate elution system.

13. A portable system for collecting and extracting a sample from a surface, the system comprising:

a wipe material held by a support structure; and

a source of pressurized wet foam;

wherein as the source of pressurized foam is introduced, the wet foam spreads substantially evenly through the wipe material to elute samples from the wipe material.

14. The system in claim 13, further comprising a collection receptacle for collecting the wet foam with sample after elution from the wipe material.

15. The system in claim 14, wherein the collection receptacle is flexible bag.

16. The system in claim 15, further comprising a sample aliquot reservoir positioned distal to the flexible bag wherein upon squeezing of the flexible bag, the sample dispenses into the aliquot reservoir.

17. The system of claim 16, further comprising a pinch valve positioned between the flexible bag and sample aliquot reservoir.

18. The system of claim 16, further comprising an adaptor positioned on a distal end of the sample aliquot reservoir to allow for direct coupling with a sample assay system.

19. The system in claim 15, wherein the source of wet foam is a portable canister.

20. The system in claim 15, wherein the source of wet foam is a separate elution system.

1/32

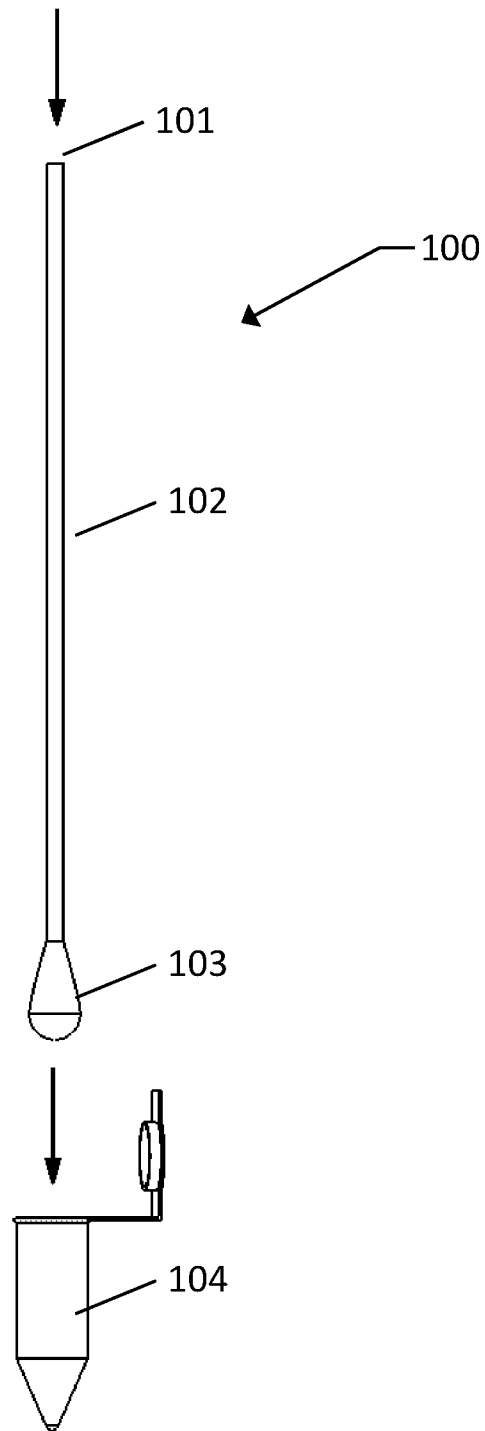

FIG. 1

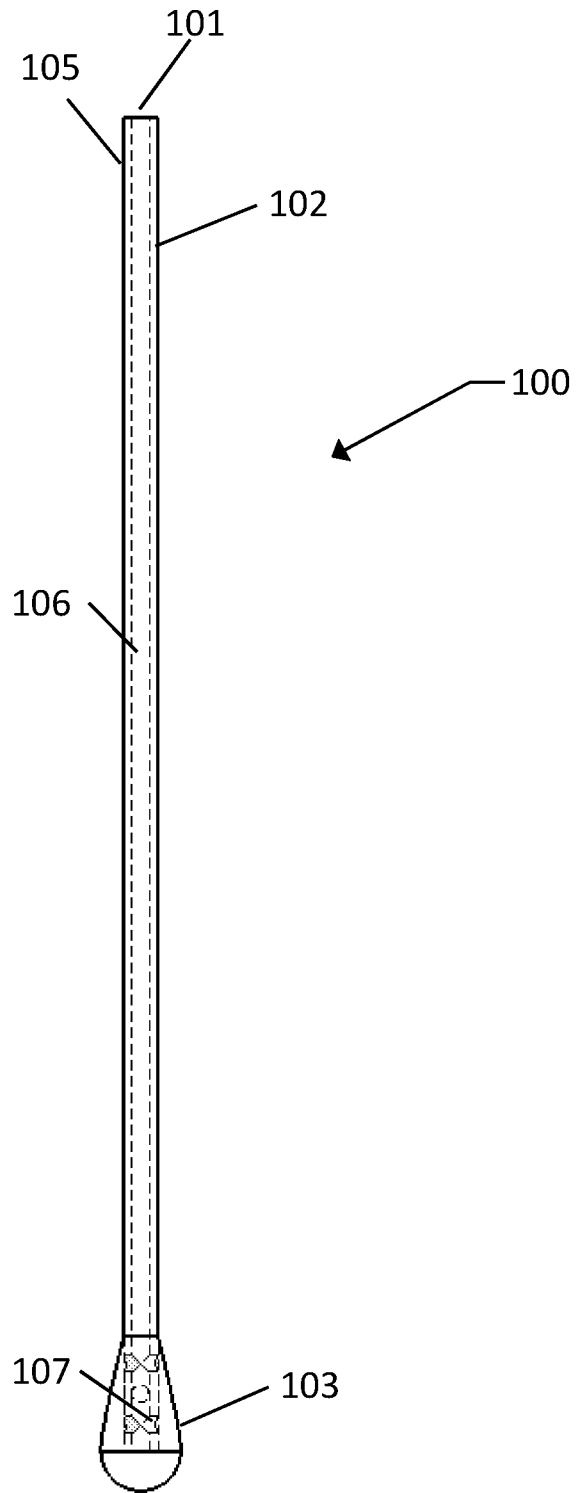

FIG. 2

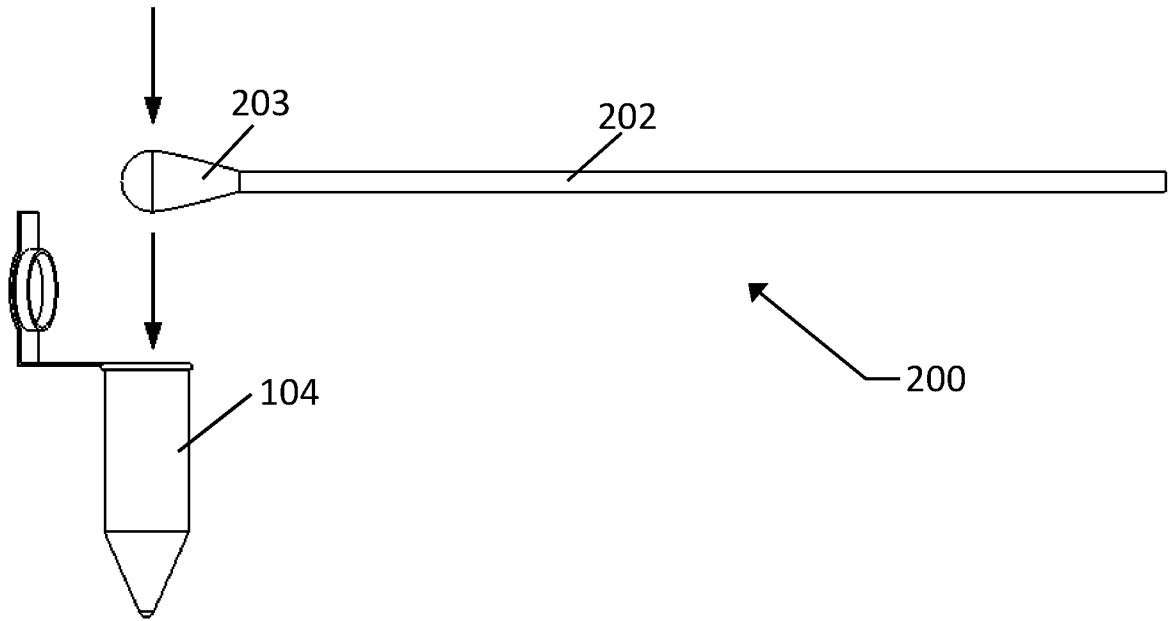

FIG. 3

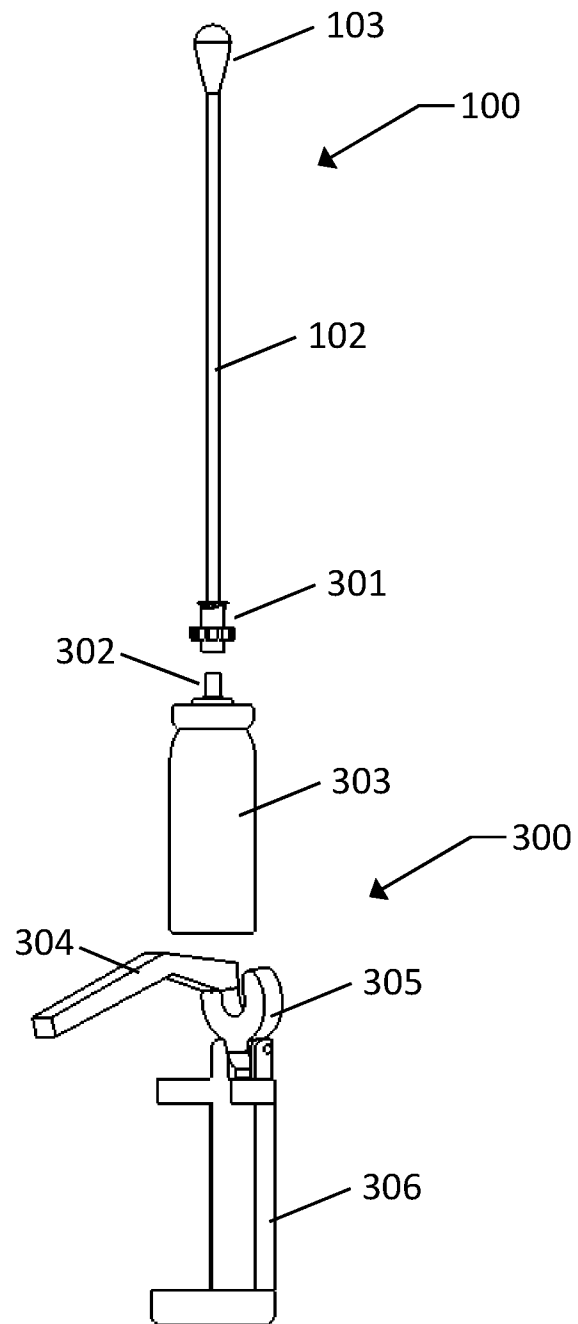

FIG. 4

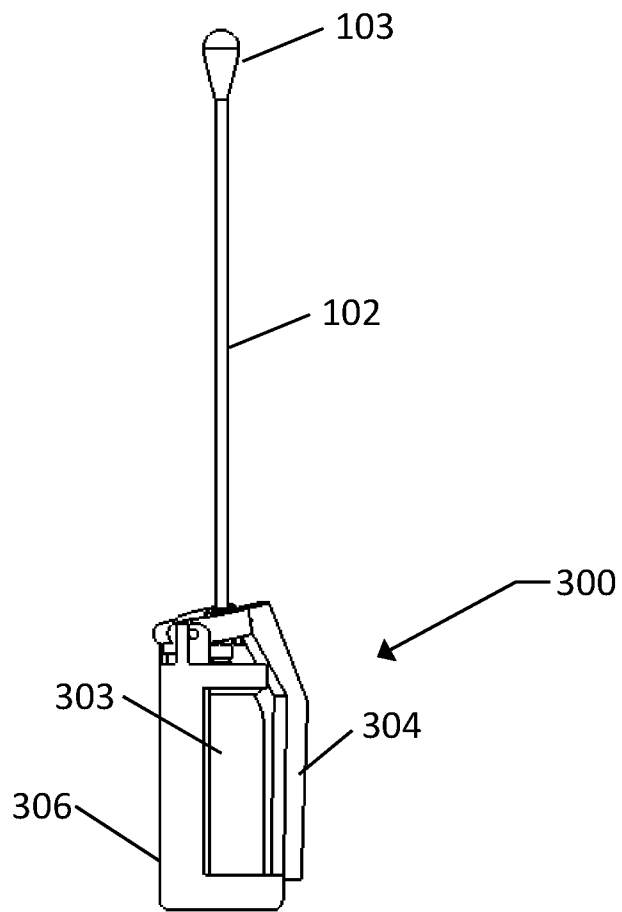

FIG. 5

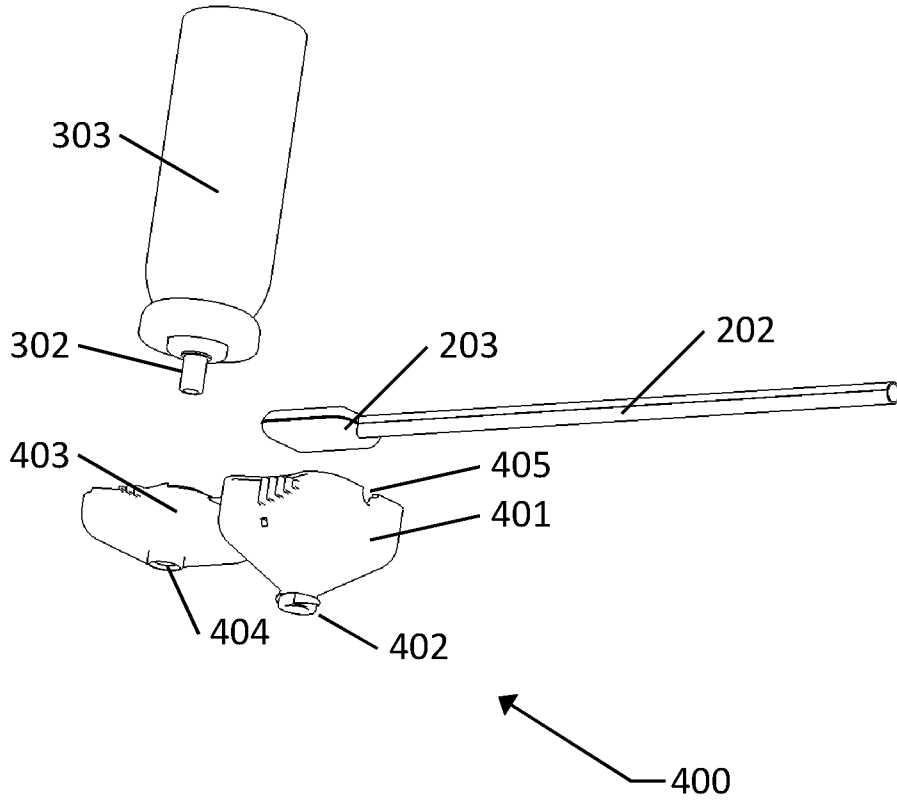

FIG. 6

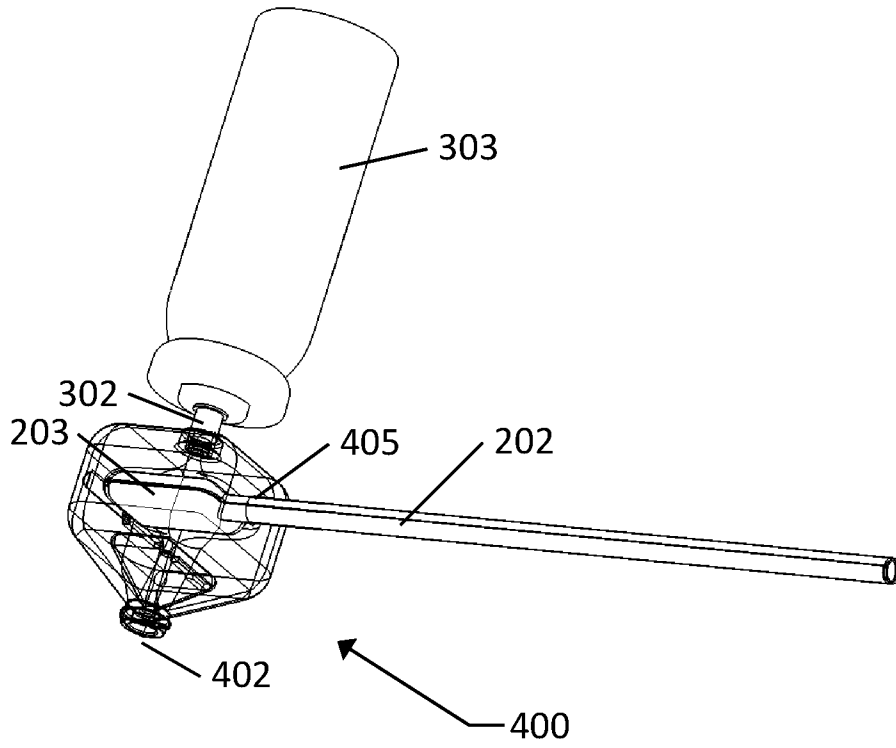

FIG. 7

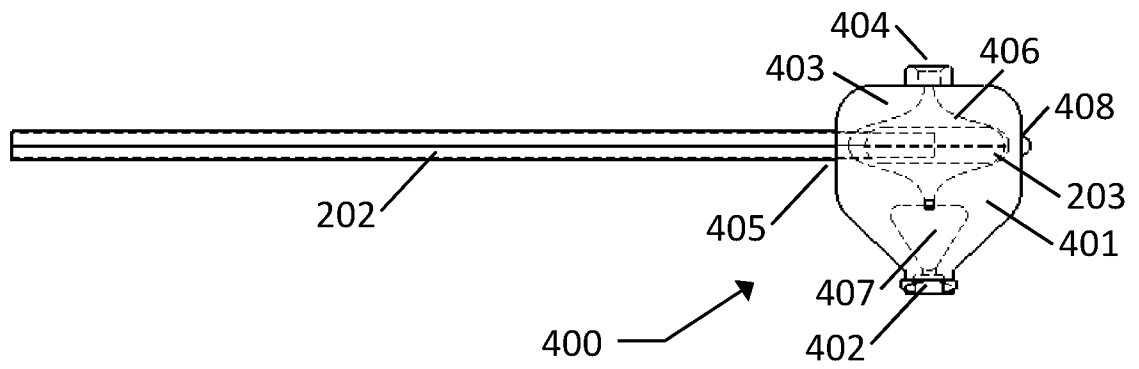

FIG. 8

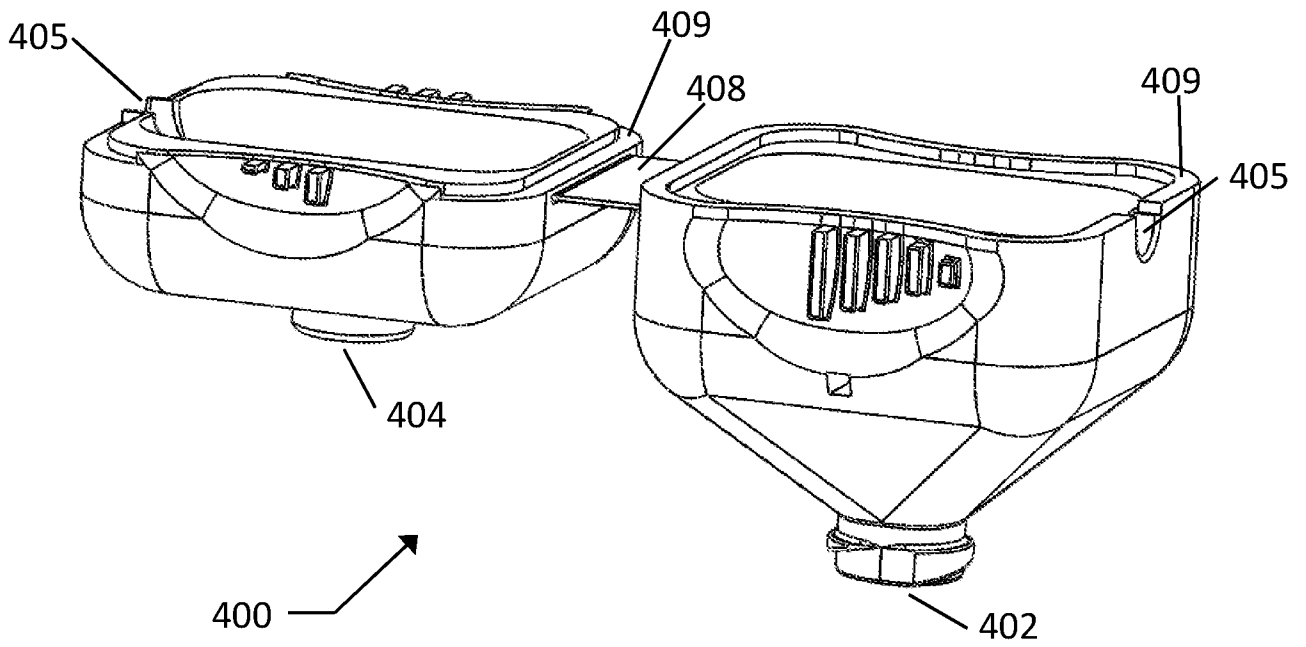

FIG. 9

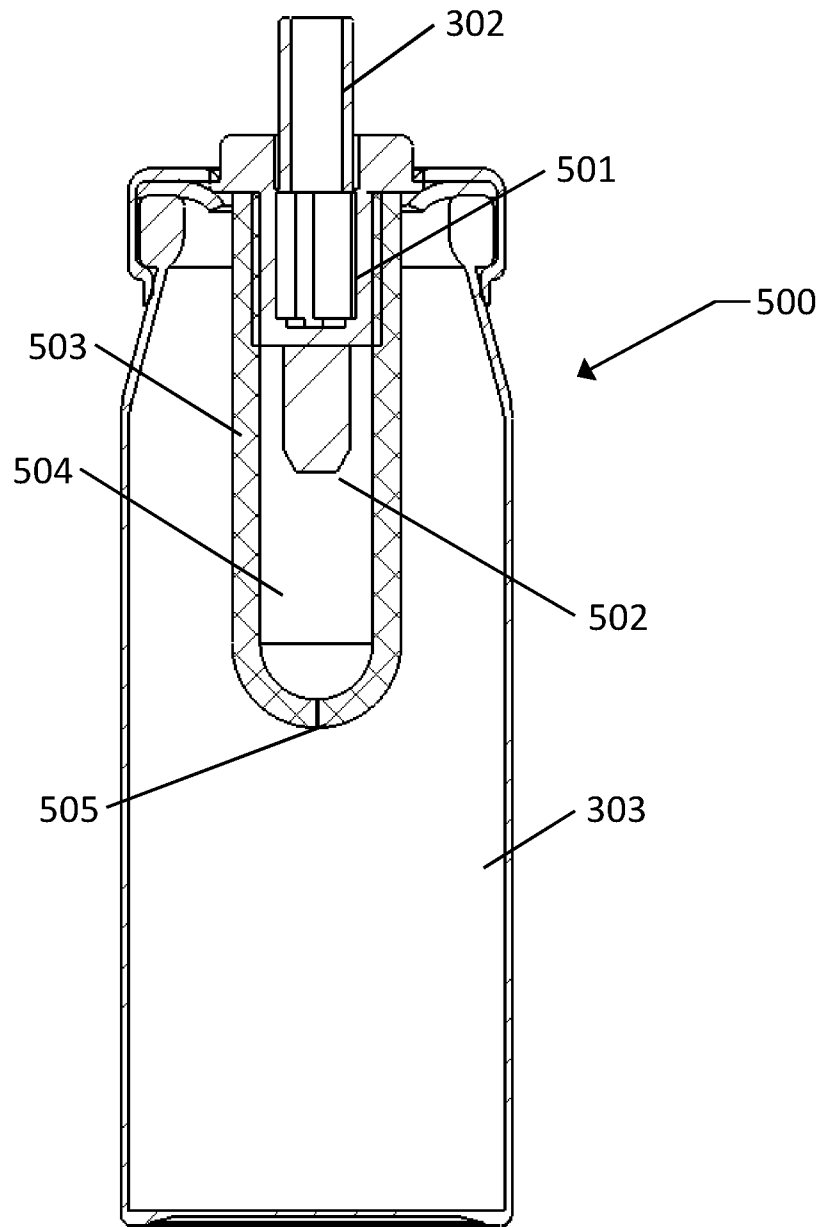

FIG. 10

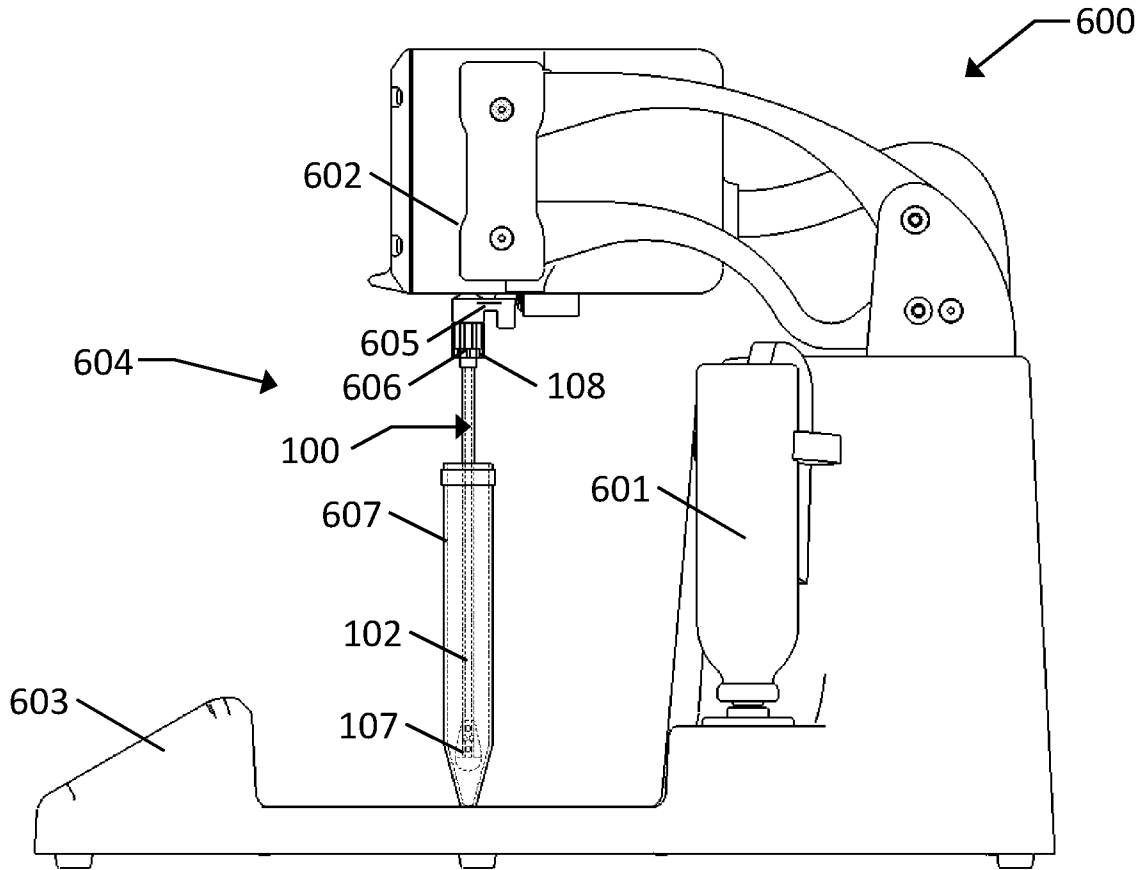

FIG. 11

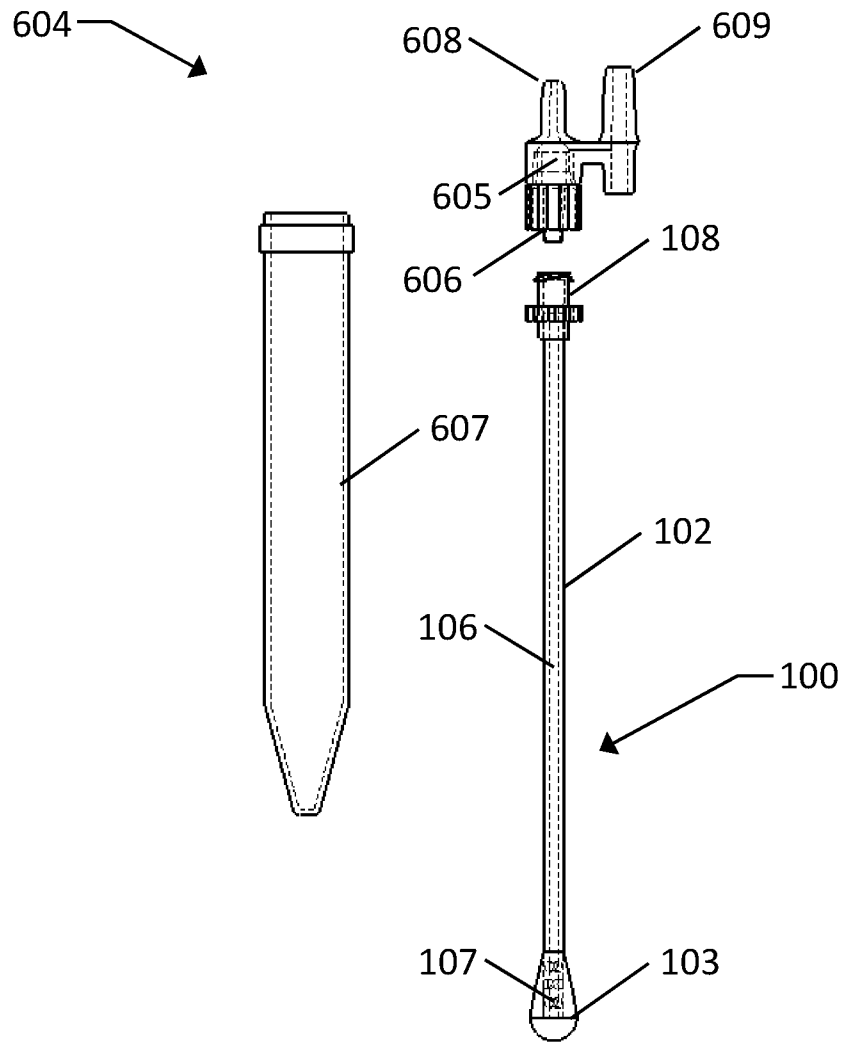

FIG. 12

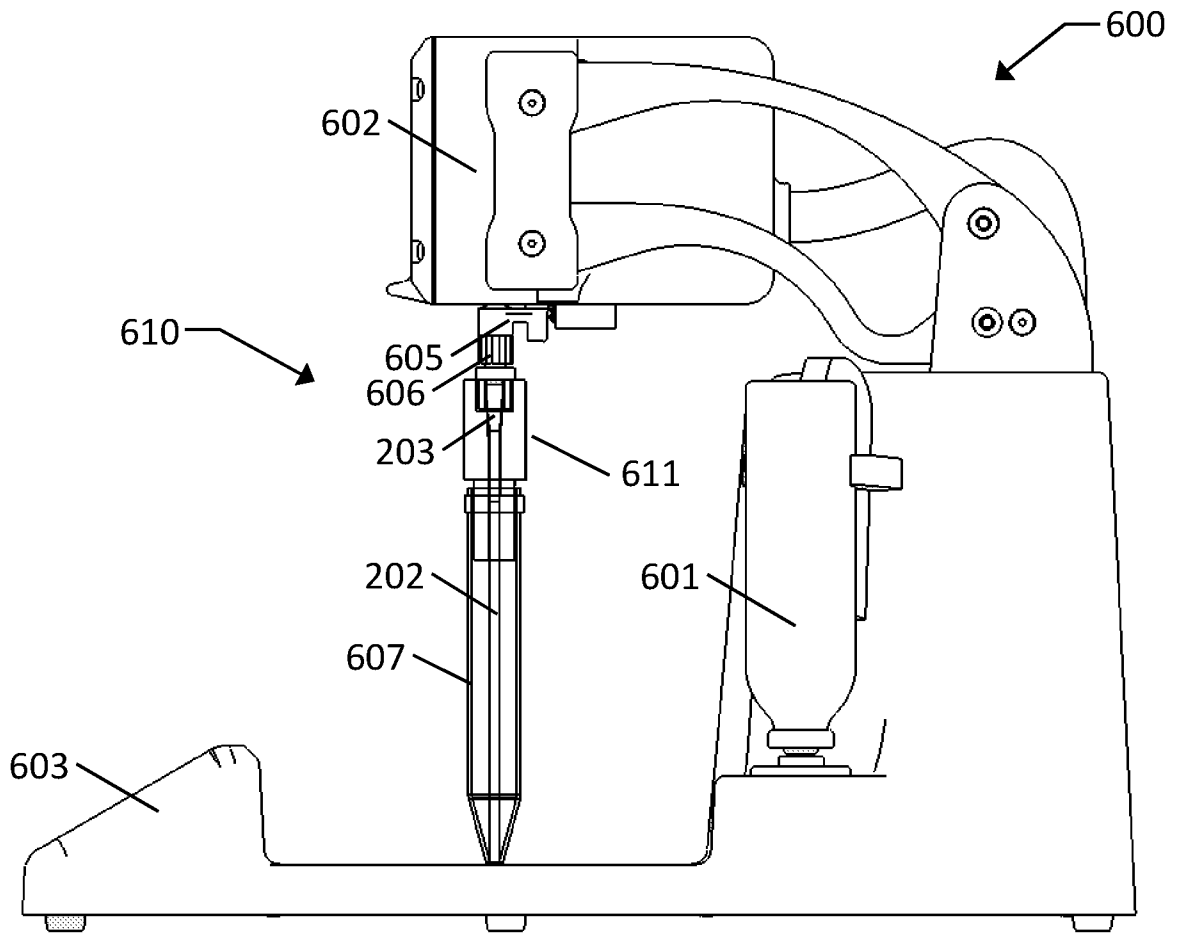

FIG. 13

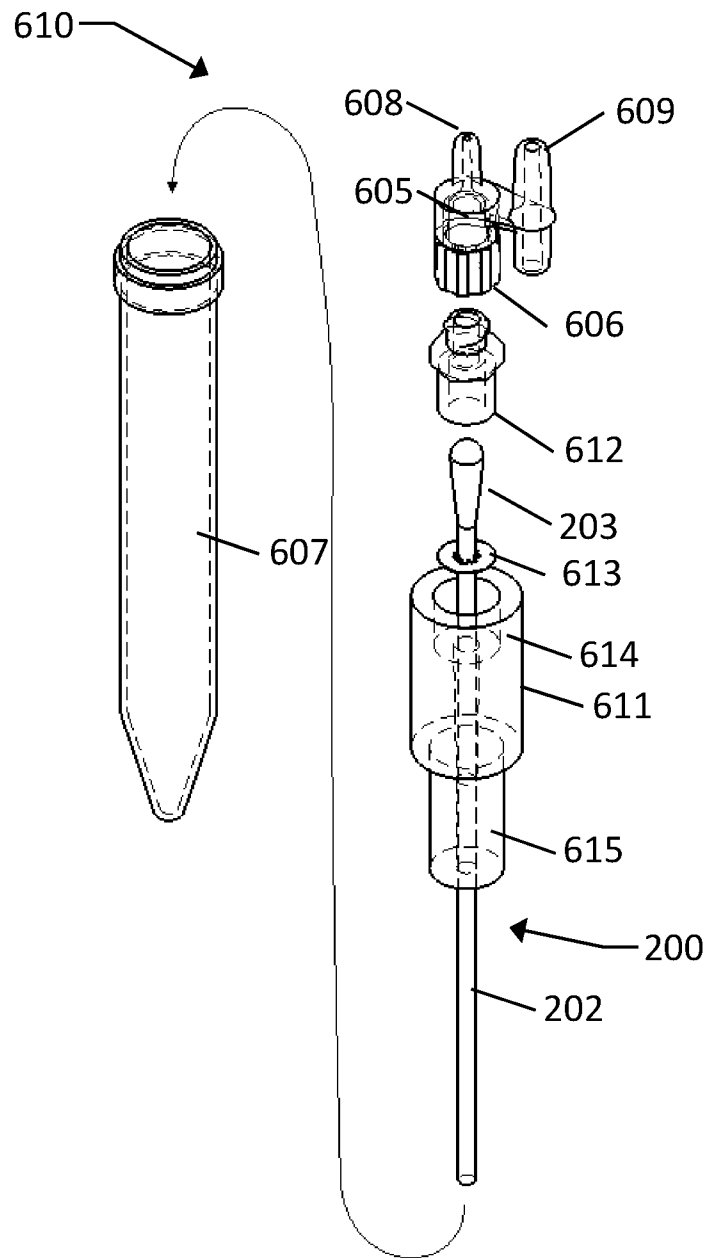

FIG. 14

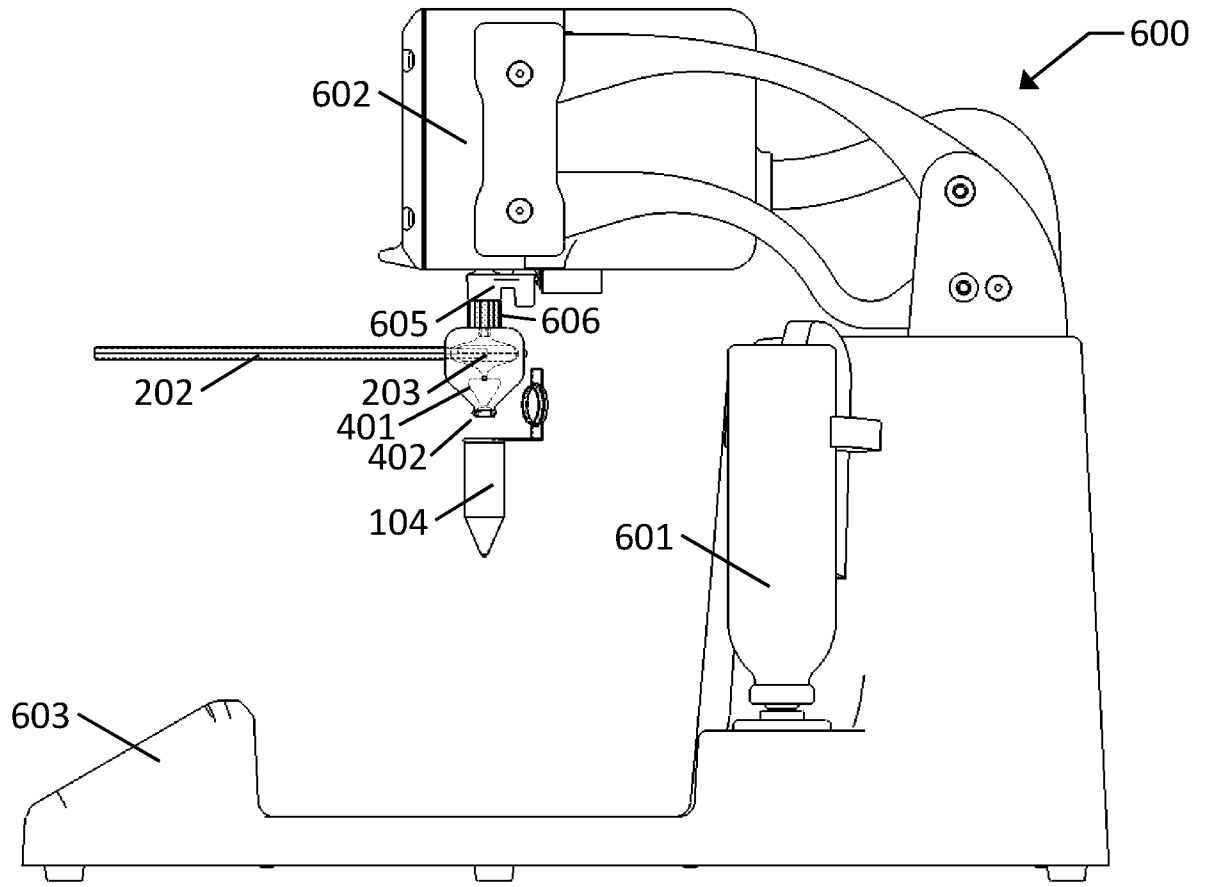

FIG. 15

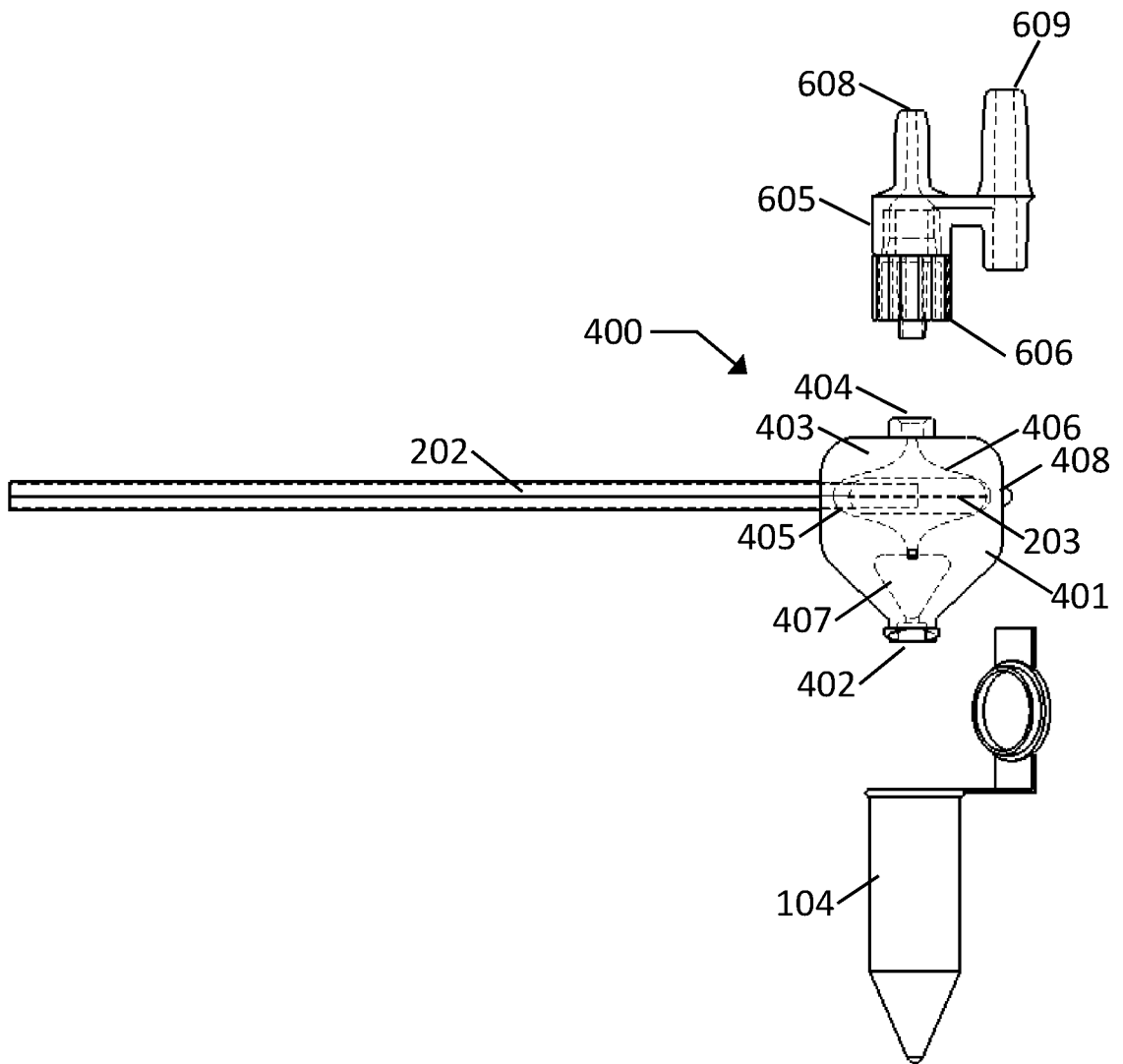

FIG. 16

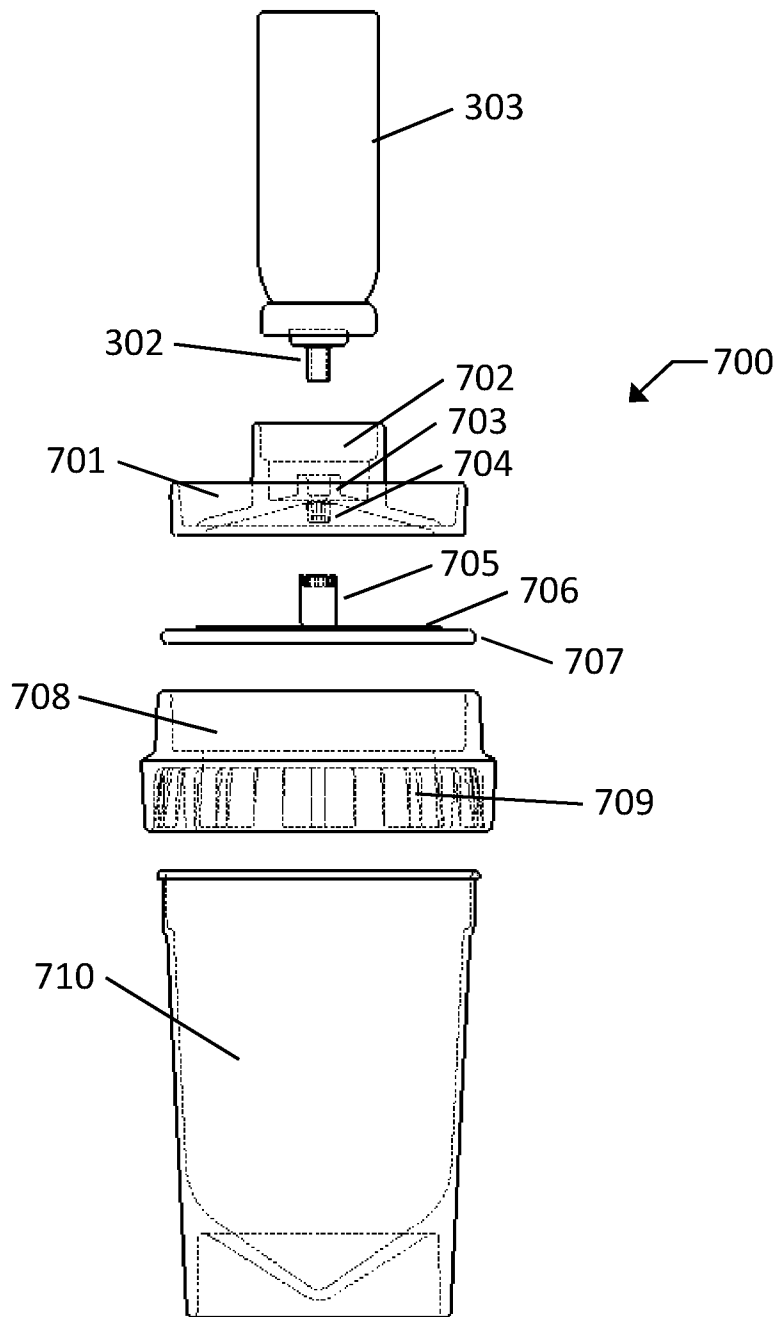

FIG. 17

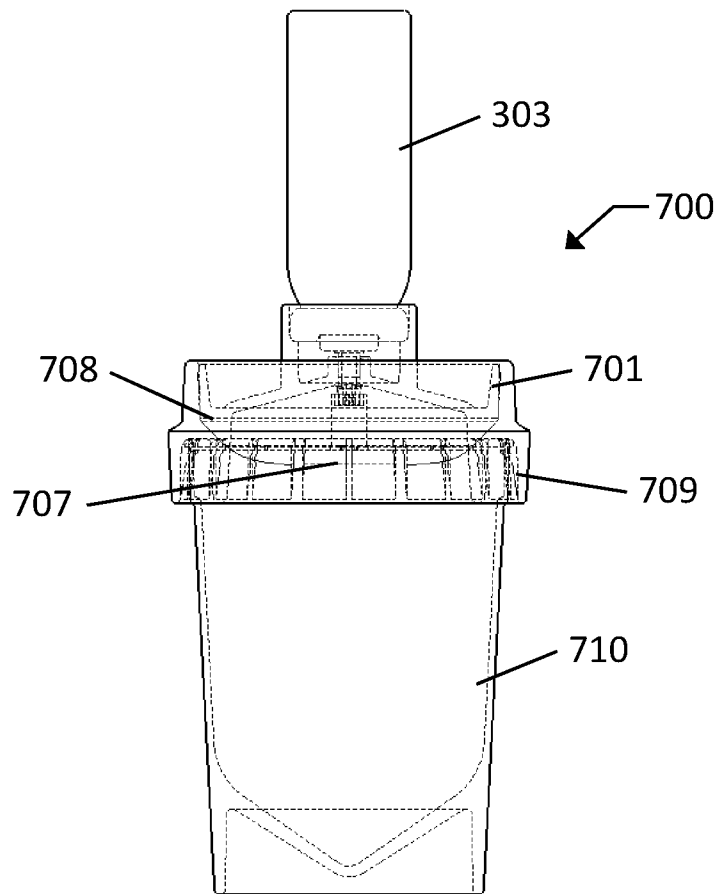

FIG. 18

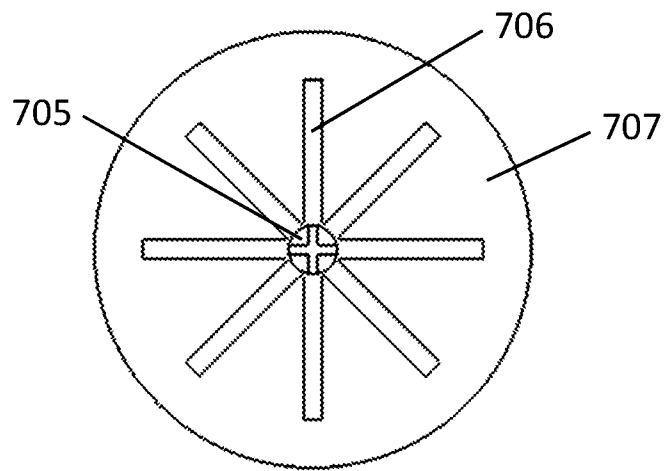

FIG. 19

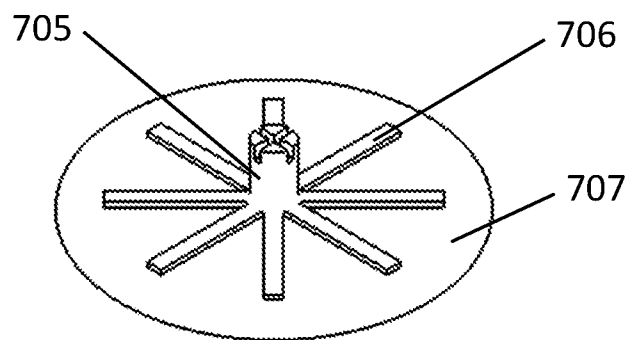

FIG. 20

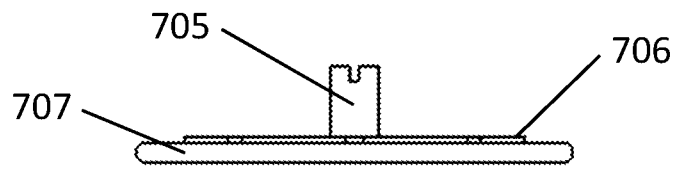

FIG. 21

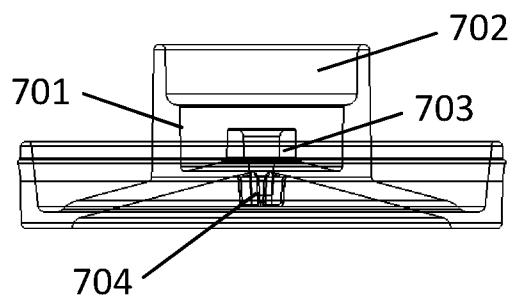

FIG. 22

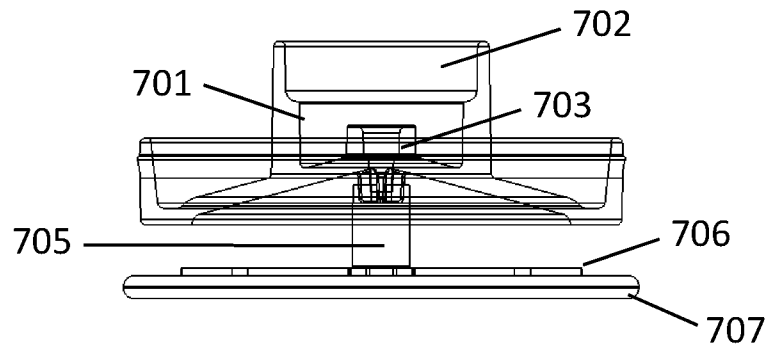

FIG. 23

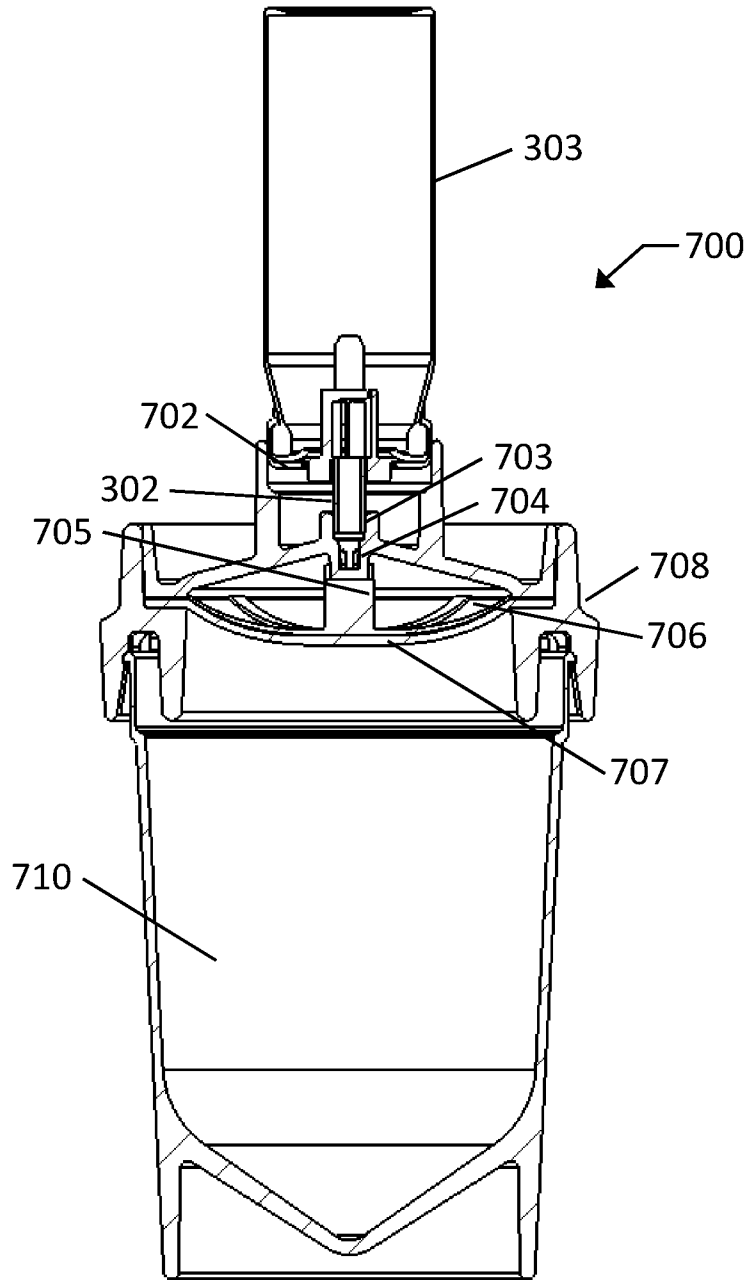

FIG. 24

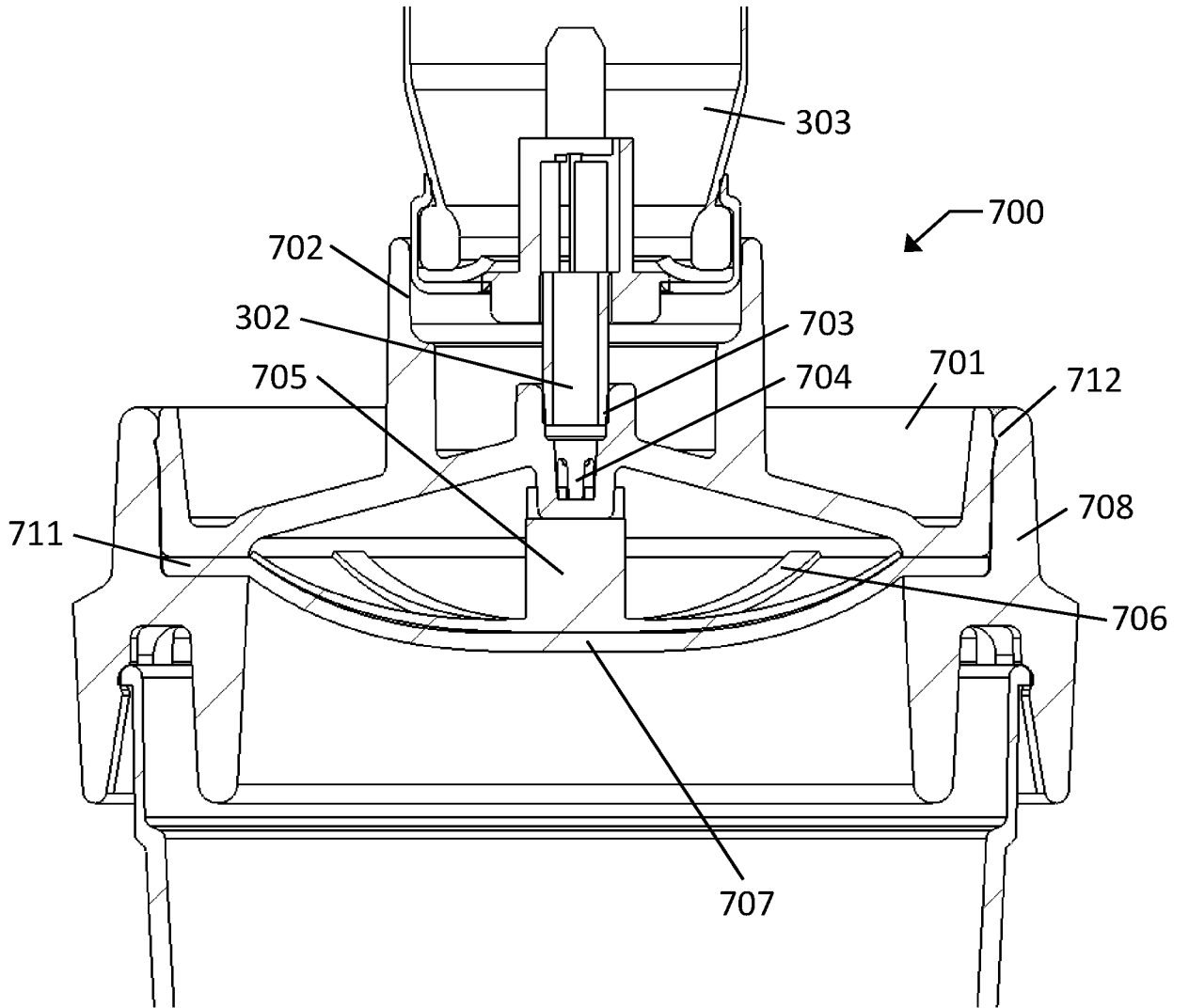

FIG. 25

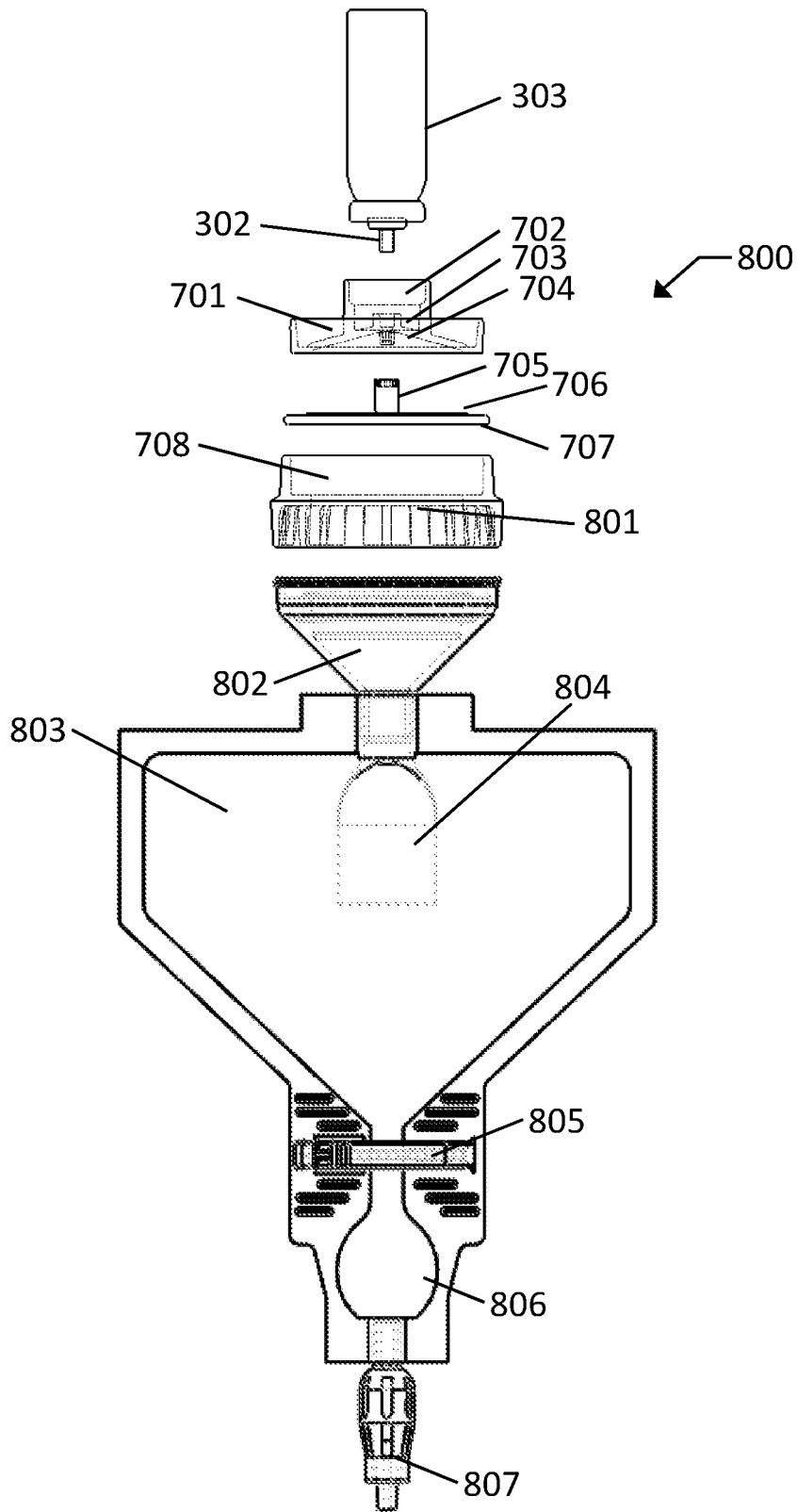

FIG. 26

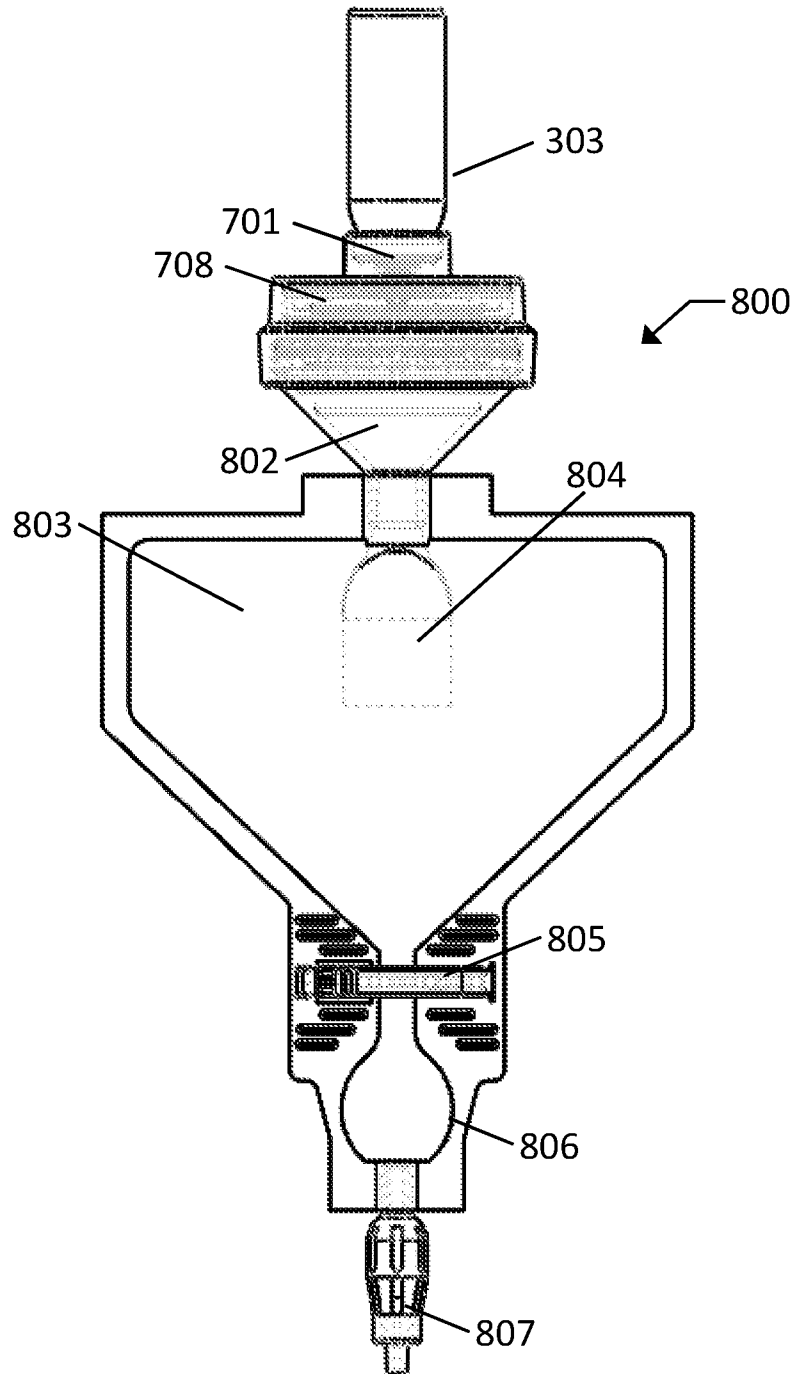

FIG. 27

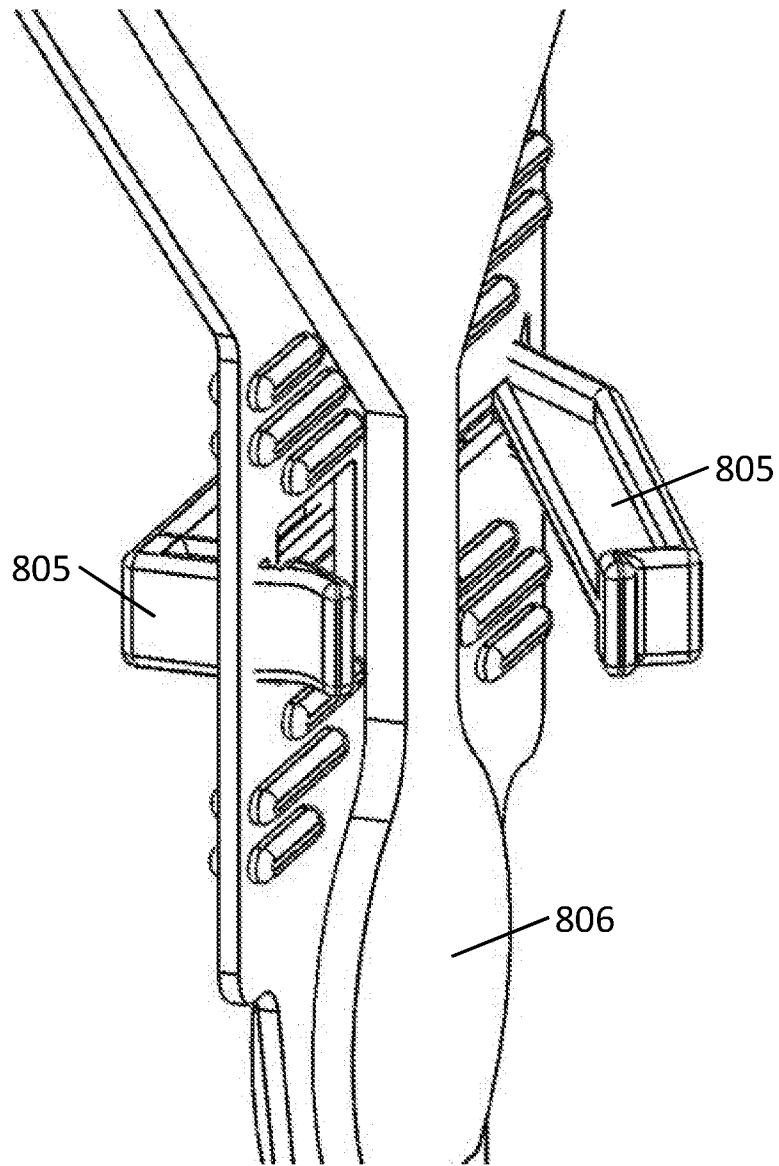

FIG. 28

27/32

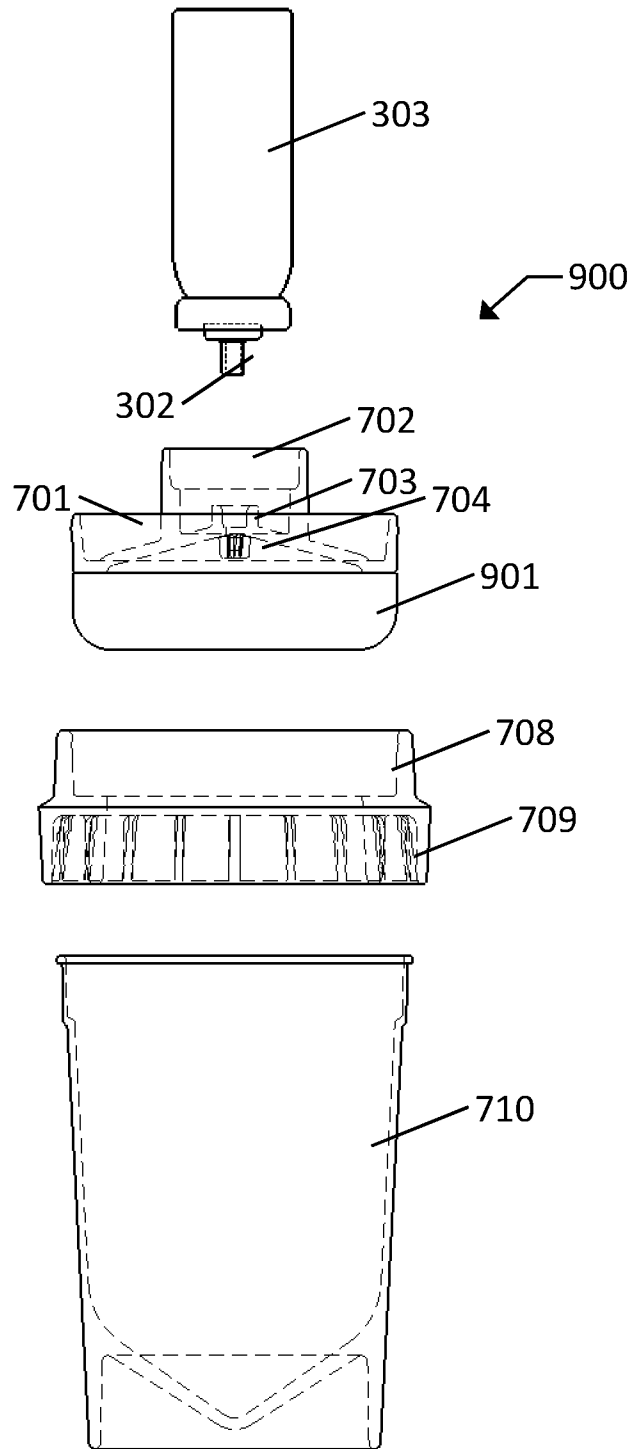

FIG. 29

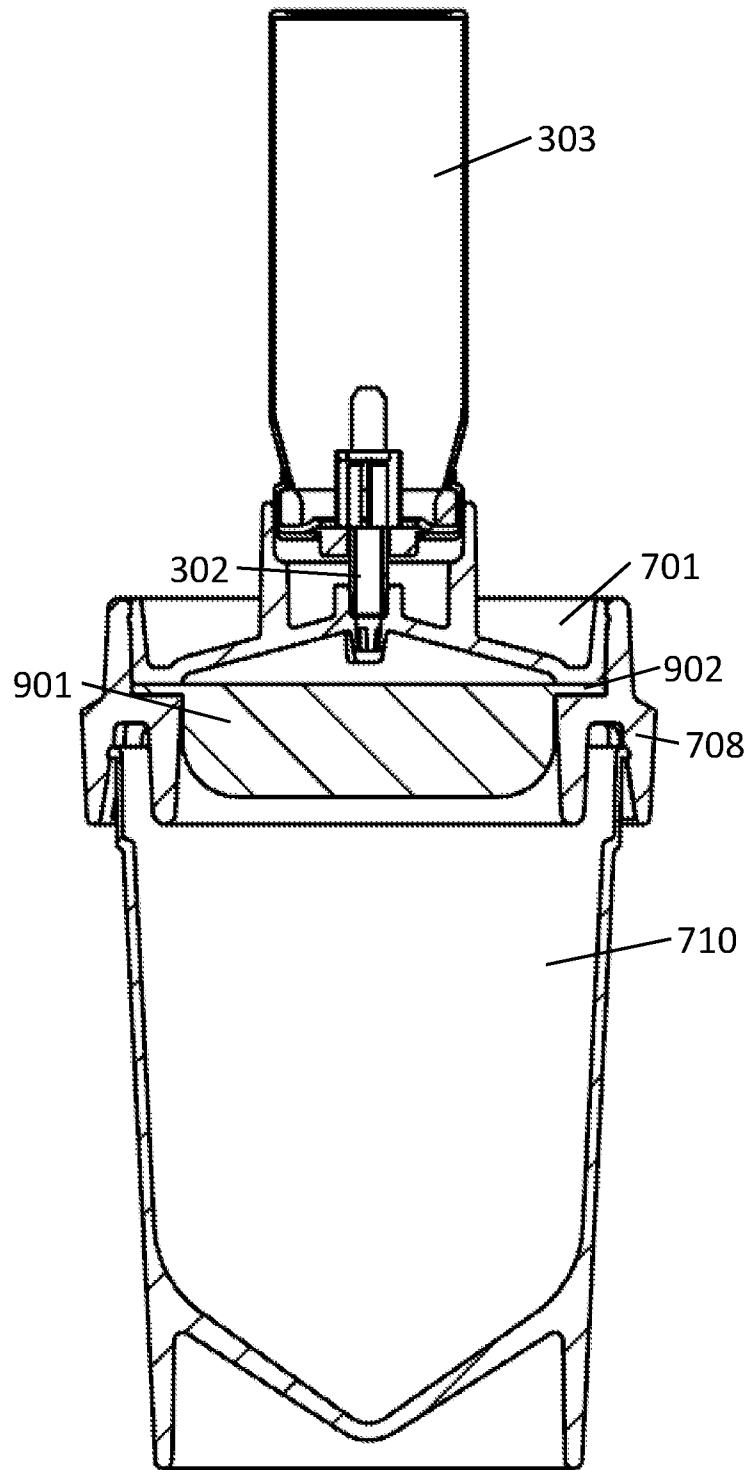

FIG. 30

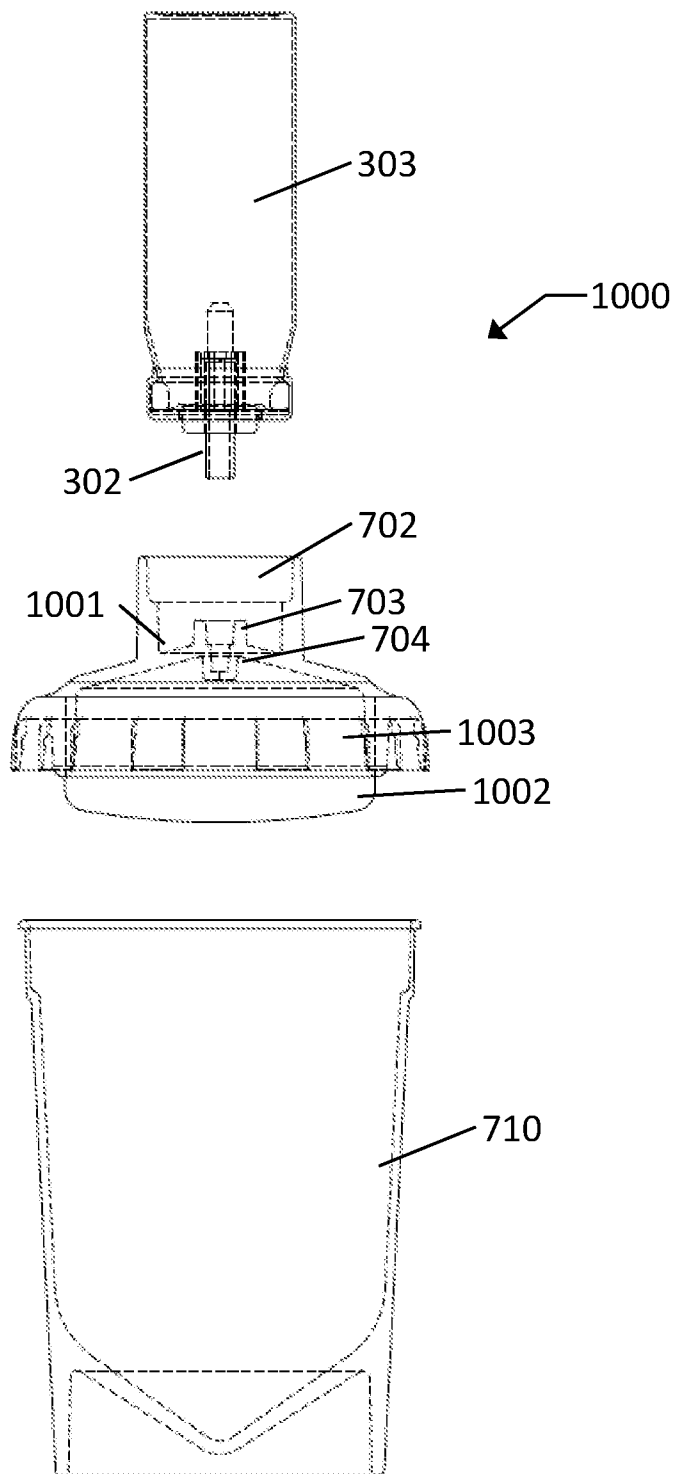

FIG. 31

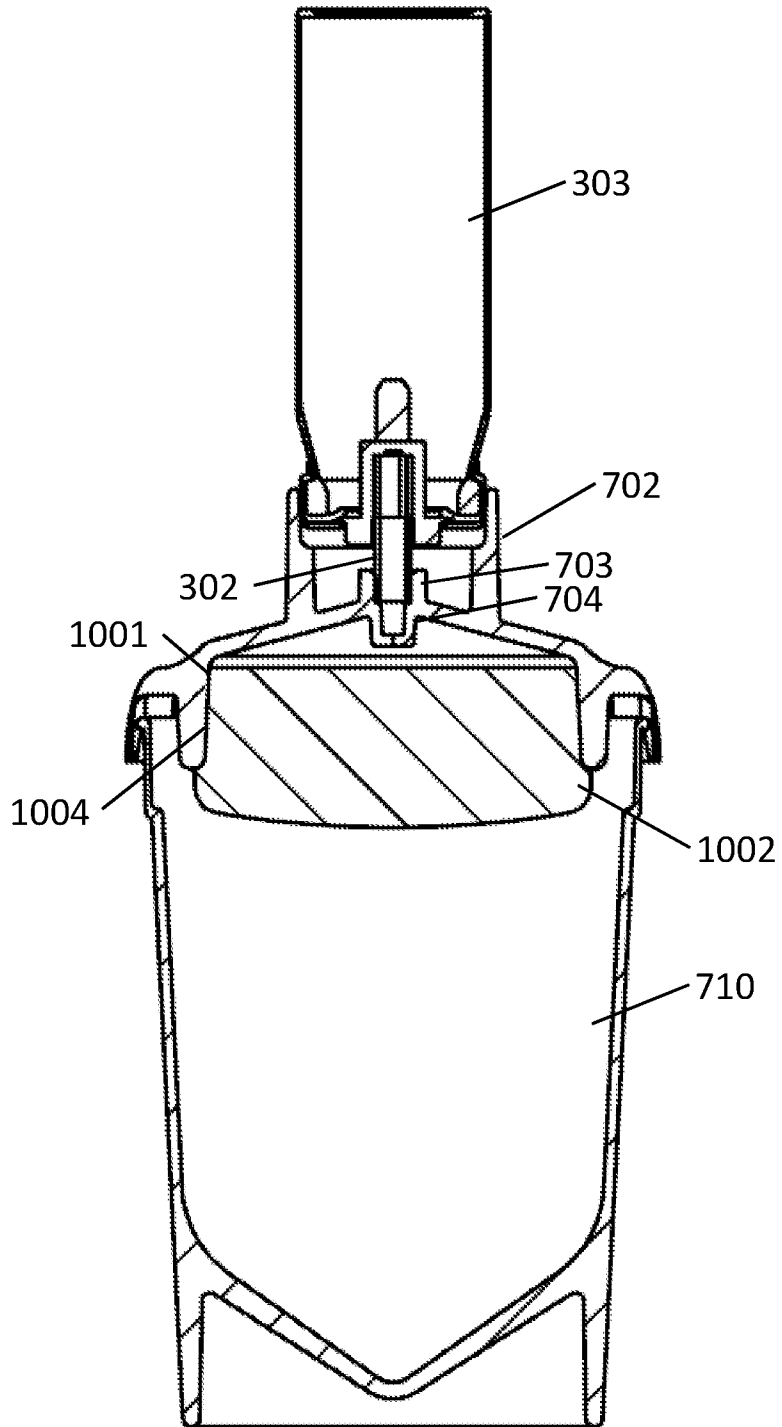

FIG. 32

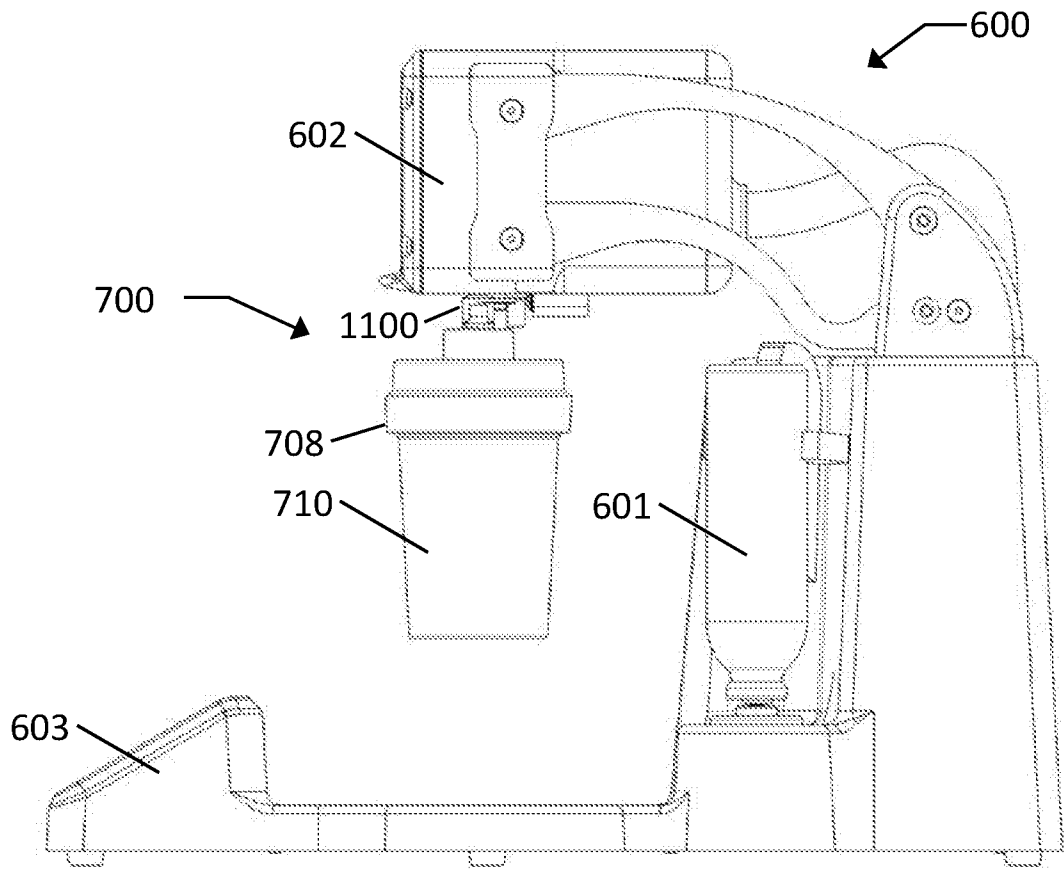

FIG. 33

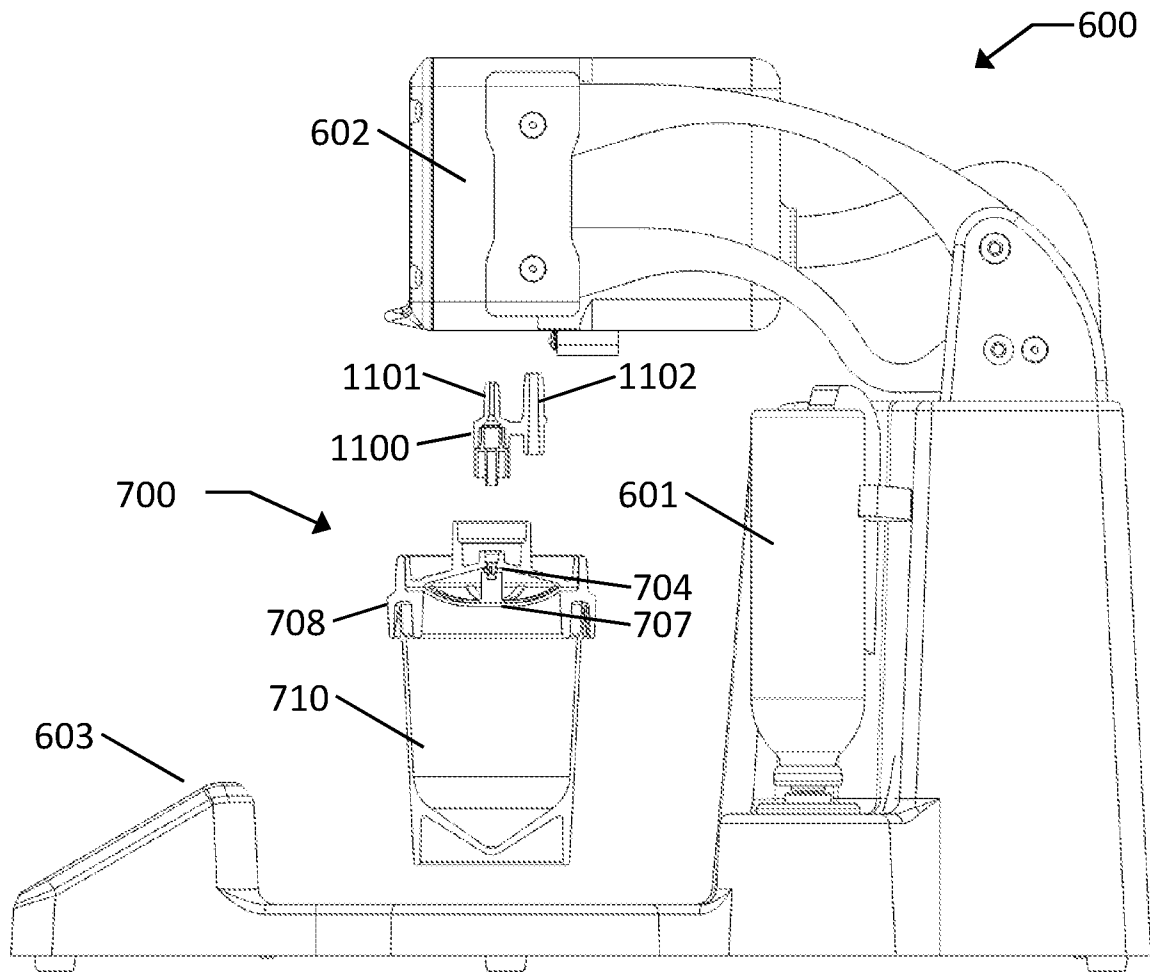

FIG. 34

INTERNATIONAL SEARCH REPORT

International application No.
PCT/US 16/28153

A. CLASSIFICATION OF SUBJECT MATTER
IPC(8) - A61F 13/38 (2016.01)
CPC - G01N 2001/028, A61F 13/38
According to International Patent Classification (IPC) or to both national classification and IPC

B. FIELDS SEARCHED
Minimum documentation searched (classification system followed by classification symbols)
IPC(8) - A61F 13/38 (2016.01)
CPC - G01N 2001/028, A61F 13/38

Documentation searched other than minimum documentation to the extent that such documents are included in the fields searched (UPC) 600/572; 73/863, 863.*; 864, 864.*; (CPC) G01N1/*, 2001/*; A61B 10/02, A61B 2010/0216, A61B 10/04; A61F 13/15 (Search term limited; see below)

Electronic data base consulted during the international search (name of data base and, where practicable, search terms used)
PubWest (PGPB, USPT, EPAB, JPAB); Google; PatBase (All);
Search Terms: Wet foam, swab*, sample, cell, specimen, sampling, collect*, remov*, wash*, elut*, extract*, express*, releas*, pressur*, compressed, foam, liquid, reagent, solvent, solution, aqueous, composition, wet, gas, gaseous, carbon dioxide, air, air bubble,

C. DOCUMENTS CONSIDERED TO BE RELEVANT

Category*	Citation of document, with indication, where appropriate, of the relevant passages	Relevant to claim No.
Y	US 2007/0244368 A1 (BAYLOFF et al.) 18 October 2007 (18.10.2007) Entire document, especially Abstract, para[0100]- para[0103] and FIGS. 1-3.	1-3, 6
Y	US 2010/0313686 A1 (PAGE et al.) 16 December 2010 (16.12.2010) Entire document, especially Abstract, para[0013], para[0015]- para[0017], para[0042], para[0045], para[0065], para[0081] and FIGS. 2, 4.	1-3, 6
Y	US 4,507,111 A (GORDON et al.) 26 March 1985 (26.03.1985) Entire document, especially Abstract, col 5, ln 41-63, col 6, ln 55- col 7, ln 3 and FIGS. 1-5.	1, 4-5
Y	US 2013/0309700 A1 (HEARN et al.) 21 November 2013 (21.11.2013) Entire document, especially Abstract, para[0057]- para[0060], and para[0088]	1, 4-5
A	US 2015/0072362 A1 (LUI et al.) 12 March 2015 (12.03.2015) Entire document.	1-6
A	US 2012/0322048 A1 (SCHULTZ et al.) 20 December 2012 (20.12.2012) Entire document.	1-6
A	US 2011/0067505 A1 (PAGE et al.) 24 March 2011 (24.03.2011) Entire document.	1-6
A	US 5,266,266 A (NASON) 30 November 1993 (30.11.1993) Entire document.	1-6
A	US 5,000,193 A (HEELIS) 19 March 1991 (19.03.1991) Entire document.	1-6

Further documents are listed in the continuation of Box C.

* Special categories of cited documents:
 "A" document defining the general state of the art which is not considered to be of particular relevance
 "E" earlier application or patent but published on or after the international filing date
 "L" document which may throw doubts on priority claim(s) or which is cited to establish the publication date of another citation or other special reason (as specified)
 "O" document referring to an oral disclosure, use, exhibition or other means
 "P" document published prior to the international filing date but later than the priority date claimed
 "T" later document published after the international filing date or priority date and not in conflict with the application but cited to understand the principle or theory underlying the invention
 "X" document of particular relevance; the claimed invention cannot be considered novel or cannot be considered to involve an inventive step when the document is taken alone
 "Y" document of particular relevance; the claimed invention cannot be considered to involve an inventive step when the document is combined with one or more other such documents, such combination being obvious to a person skilled in the art
 "&" document member of the same patent family

Date of the actual completion of the international search 31 August 2016 (31.08.2016)	Date of mailing of the international search report 26 SEP 2016
--	--

Name and mailing address of the ISA/US Mail Stop PCT, Attn: ISA/US, Commissioner for Patents P.O. Box 1450, Alexandria, Virginia 22313-1450 Facsimile No. 571-273-8300	Authorized officer: Lee W. Young PCT Helpdesk: 571-272-4300 PCT OSP: 571-272-7774
---	---

INTERNATIONAL SEARCH REPORT

International application No.

PCT/US 16/28153

Box No. II Observations where certain claims were found unsearchable (Continuation of item 2 of first sheet)

This international search report has not been established in respect of certain claims under Article 17(2)(a) for the following reasons:

1. Claims Nos.:
because they relate to subject matter not required to be searched by this Authority, namely:

2. Claims Nos.:
because they relate to parts of the international application that do not comply with the prescribed requirements to such an extent that no meaningful international search can be carried out, specifically:

3. Claims Nos.:
because they are dependent claims and are not drafted in accordance with the second and third sentences of Rule 6.4(a).

Box No. III Observations where unity of invention is lacking (Continuation of item 3 of first sheet)

This International Searching Authority found multiple inventions in this international application, as follows:

--- see extra sheet ---

1. As all required additional search fees were timely paid by the applicant, this international search report covers all searchable claims.
2. As all searchable claims could be searched without effort justifying additional fees, this Authority did not invite payment of additional fees.
3. As only some of the required additional search fees were timely paid by the applicant, this international search report covers only those claims for which fees were paid, specifically claims Nos.:
4. No required additional search fees were timely paid by the applicant. Consequently, this international search report is restricted to the invention first mentioned in the claims; it is covered by claims Nos.:
1-6

Remark on Protest

- The additional search fees were accompanied by the applicant's protest and, where applicable, the payment of a protest fee.
- The additional search fees were accompanied by the applicant's protest but the applicable protest fee was not paid within the time limit specified in the invitation.
- No protest accompanied the payment of additional search fees.

INTERNATIONAL SEARCH REPORT

International application No.
PCT/US 16/28153

----- Continuation of Box III: Observations where unity of invention is lacking (Continuation of item 3 of first sheet) -----

This application contains the following inventions or groups of inventions which are not so linked as to form a single general inventive concept under PCT Rule 13.1. In order for all inventions to be examined, the appropriate additional examination fees must be paid.

Group I: Claims 1-6 directed to a swab device with a hollow shaft through which pressurized wet foam can be introduced to elute a sample

Group II: Claims 7-12 directed to a swab device and a clam-shell cartridge configured to seal the head of the swab device, into which pressurized wet foam can be introduced to elute a sample

Group III: Claims 13-20 directed to a wipe material with a support structure onto which pressurized foam can be dispensed to elute a sample

The inventions listed as Groups I-III do not relate to a single inventive concept under PCT Rule 13.1 because under PCT Rule 13.2 they lack the same or corresponding technical features for the following reasons:

Special Technical Features

Group I includes the special technical feature of an extended shaft having a lumen that extends substantially throughout the length of the shaft, and means on the end of the shaft to allow introduction of a substance, not required in any other group.

Group II includes the special technical feature of a clam shell cartridge which accommodates the swab head such that the swab head is substantially sealed within a chamber inside the closed cartridge, and means on the cartridge to allow introduction of a substance, not required in any other group.

Group III includes the special technical feature of a wipe material held by a support structure, and means to spread a substance substantially evenly through the wipe material, not required in any other group.

Common Technical Features

Groups I-III share the technical features of a source of pressurized wet foam capable of eluting a sample from a material.

Groups I-II further share the technical feature of a swab.

However, these common technical features are anticipated by US 2013/0309700 A1 to Hearn et al. (hereinafter: Hearn). Hearn describes a source of pressurized wet foam capable of eluting a sample from a material (para[0057]-[0058]: expulsion buffer ... is a foam ... with gas under pressure; also see para[0060] describing pump as source). Hearn also describes the collection material being a swab (para[0088]).

Accordingly, Groups I-III lack unity under PCT Rule 13.