



(51) International Patent Classification:

B44B 3/06 (2006.01) B44C 1/02 (2006.01)
B44B 7/00 (2006.01) B44C 1/14 (2006.01)

(21) International Application Number:

PCT/US2019/012945

(22) International Filing Date:

09 January 2019 (09.01.2019)

(25) Filing Language:

English

(26) Publication Language:

English

(30) Priority Data:

62/689,376 25 June 2018 (25.06.2018) US
62/787,379 01 January 2019 (01.01.2019) US
16/244,031 09 January 2019 (09.01.2019) US

(71) Applicant: **AMERICAN CRAFTS, L.C.** [US/US]; 588 West 400 South, Suite 300, Lindon, Utah 84042 (US).

(72) Inventor: **FOURIE, Nicolas Stephans**; 169 Oueniqua Ave., Waterkloof Park, 0181 Pretoria, GT (ZA).

(74) Agent: **POWER, Brick**; Durham Jones & Pinegar, P.C., 3301 N. Thanksgiving Way, Suite 400, Lehi, Utah 84043 (US).

(81) Designated States (unless otherwise indicated, for every kind of national protection available): AE, AG, AL, AM, AO, AT, AU, AZ, BA, BB, BG, BH, BN, BR, BW, BY, BZ, CA, CH, CL, CN, CO, CR, CU, CZ, DE, DJ, DK, DM, DO, DZ, EC, EE, EG, ES, FI, GB, GD, GE, GH, GM, GT, HN, HR, HU, ID, IL, IN, IR, IS, JO, JP, KE, KG, KH, KN, KP, KR, KW, KZ, LA, LC, LK, LR, LS, LU, LY, MA, MD, ME, MG, MK, MN, MW, MX, MY, MZ, NA, NG, NI, NO, NZ, OM, PA, PE, PG, PH, PL, PT, QA, RO, RS, RU, RW, SA, SC, SD, SE, SG, SK, SL, SM, ST, SV, SY, TH, TJ, TM, TN, TR, TT, TZ, UA, UG, US, UZ, VC, VN, ZA, ZM, ZW.

(84) Designated States (unless otherwise indicated, for every kind of regional protection available): ARIPO (BW, GH, GM, KE, LR, LS, MW, MZ, NA, RW, SD, SL, ST, SZ, TZ, UG, ZM, ZW), Eurasian (AM, AZ, BY, KG, KZ, RU, TJ, TM), European (AL, AT, BE, BG, CH, CY, CZ, DE, DK, EE, ES, FI, FR, GB, GR, HR, HU, IE, IS, IT, LT, LU, LV,

(54) Title: HEAT PEN FOR USE WITH ELECTRONIC CUTTING AND/OR DRAWING SYSTEMS

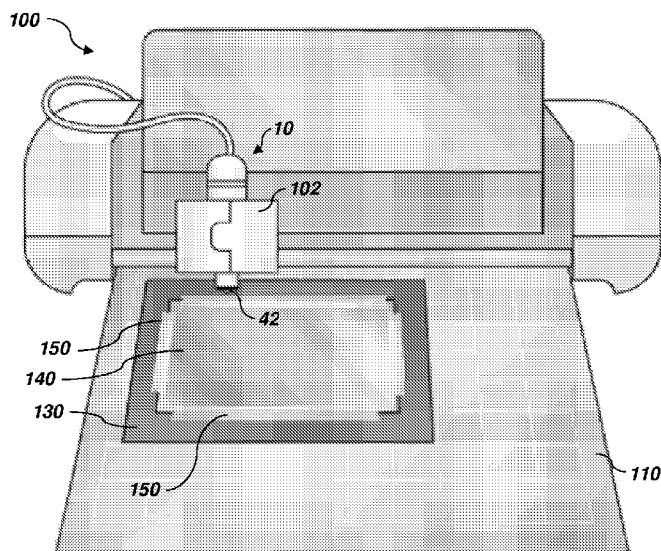

FIG. 10

(57) Abstract: A heat pen may be used with an electronic cutting and/or drawing system to enable the electronic cutting and/or drawing system to use heat to define text and/or designs on a substrate. The heat pen may be coupled with a cradle of an electronic cutting and/or drawing system directly or by assembling an adapter with the heat pen. Power may be supplied to the heat pen by electrically coupling the heat pen to an external power supply, such as a power and/or communications port of the electronic cutting and/or drawing system. Electronic heated design systems and methods for modifying substrates using heat are also disclosed.



MC, MK, MT, NL, NO, PL, PT, RO, RS, SE, SI, SK, SM,
TR), OAPI (BF, BJ, CF, CG, CI, CM, GA, GN, GQ, GW,
KM, ML, MR, NE, SN, TD, TG).

Published:

— *with international search report (Art. 21(3))*

HEAT PEN FOR USE WITH ELECTRONIC CUTTING AND/OR DRAWING SYSTEMS

CROSS-REFERENCE TO RELATED APPLICATION

5 Claims for priority to the January 1, 2019 filing date of U.S. Provisional Patent Application No. 62/787,379, titled HEAT PEN FOR USE WITH ELECTRONIC CUTTING AND/OR DRAWING SYSTEMS (“the ’379 Provisional Application”) and to the June 25, 2018 filing date of U.S. Provisional Patent Application No. 62/689,376, titled HEAT PEN FOR USE WITH ELECTRONIC CUTTING AND/OR DRAWING
10 SYSTEMS (“the ’376 Provisional Application”) are hereby made. The entire disclosures of the ’379 Provisional Application and the ’376 Provisional Application are hereby incorporated herein.

TECHNICAL FIELD

15 This disclosure relates generally to tools that may be used with electronic cutting and/or drawing systems and, more specifically, to a heat pen that may be used with an electronic cutting and/or drawing system.

DISCLOSURE

20 A heat pen according to this disclosure has a configuration that enables it to be used in place of a blade and/or a pen of an electronic cutting and/or drawing system. Accordingly, such a heat pen may also be referred to as an “insert.” A heat pen, or insert, may include a housing, a heating element, and a power supply.

 The housing of the heat pen, or insert, may have a configuration that enables it to
25 be received by a cradle of one or more types of electronic cutting and/or drawing systems. In some embodiments, the housing of the heat pen may have dimensions that enable it to be received by and, optionally, coupled to cradles of a plurality of different types of electronic cutting and/or drawing systems, either alone or with an adapter. More specifically, the housing, along with any adapter that has been assembled therewith, may
30 have a configuration that, when the heat pen is assembled with the cradle of an electronic cutting and/or drawing system, enables a bottom of the housing to face a support mat and any substrate positioned on the support mat. Without limitation, the housing may have an elongated configuration.

The housing of the heat pen carries the heating element of the heat pen. The heating element may be carried in such a way that a tip of the heating element protrudes beyond the bottom of the housing of the heat pen. The tip may have a configuration that enables it to be used for one or more intended purposes. As an example, the tip may be
5 flat or somewhat rounded. A flat or rounded tip may be useful for laminating one type of media (*e.g.*, a reactive foil, such as a heat-activated foil, etc.) to a sheet of another type of media (*e.g.*, paper, cardstock, etc.). As another example, the tip may be pointed or beveled. A pointed or beveled tip may be useful for wood burning.

A remainder of the heating element of the heat pen may have a configuration that
10 enables the tip to be heated. The remainder of the heating element, along with any thermally insulating components or features that surround the heating element, may be located within the housing of the heat pen.

The power supply of the heat pen provides sufficient power to the heating element to enable the heating element to be heated to a temperature sufficient to enable the tip of
15 the heating element to perform a desired function (*e.g.*, laminate reactive foil onto a sheet of media, burn wood, etc.). The power supply may be at least partially carried by (*e.g.*, within, etc.) the housing of the heat pen. In some embodiments, the power supply may comprise a cable that has been coupled to the heating element at a location within the housing, that extends from a top of the housing, and that may be capable of electrically
20 coupling the heating element to an external power supply, such as an electrical outlet, a powered communications port (*e.g.*, a universal serial bus (USB) type port, etc.) of the electronic cutting and/or drawing system, and/or a powered communications port of a computer. Alternatively, the power supply may comprise a rechargeable battery, which may be recharged with a removable cable (*e.g.*, a USB cable, etc.). In some embodiments,
25 a switch (*e.g.*, a manual electrical switch, and automatic shutoff, etc.) may control the flow of electricity to the heating element.

Optionally, one or more adapters may be provided with the heat pen. Each adapter may be capable of assembly with the housing of the heat pen in a manner that enables the heat pen to be properly assembled with and secured to the cradle of a particular,
30 corresponding electronic cutting and/or drawing system. Such an adapter may include a receptacle with a configuration complementary to a configuration of an exterior surface of at least a portion of the housing of the heat pen. An exterior surface of the adapter may have a configuration complementary to a configuration of at least a portion of a receptacle

of the cradle of the corresponding electronic cutting and/or drawing system; thus, the adapter may enable the heat pen to fit securely within the receptacle of the cradle. In some embodiments, each adapter may be capable of sliding onto and off of the housing the heat pen. In other embodiments, each adapter may be mechanically secured into place
5 on the housing of the heat pen (*e.g.*, by way of complementary threading, a complementary locking mechanism, a snap fit, etc.).

In another aspect, electronic heated design systems that are capable of selectively heating substrates to decoratively modify the substrate are disclosed. Such an electronic heated design system may comprise an electronic cutting and/or drawing system, such as
10 a CRICUT® electronic cutting and/or drawing system available from Provo Craft and Novelty, Inc., of South Jordan, Utah, or a CAMEO® electronic cutting and/or drawing system available from Silhouette America, Inc., of Lindon, Utah. The electronic heated design system may include a support mat, a heating element, a carriage, a cradle, a processor, and memory. The support mat may be capable of receiving and supporting a
15 substrate. The heating element, which may comprise a heat pen of this disclosure, includes a tip capable of being positioned against the substrate and of applying heat to the substrate. The carriage and the cradle may be capable of positioning the tip of the heating element against the substrate, and in moving the tip to selected locations over the substrate. The memory may store instructions for controlling operation of the carriage
20 (*i.e.*, its movement of the cradle and the tip of the heating element), and the processor may access those instructions from the memory and execute them to control operation of the carriage and, thus, movement of the tip of the heating element in a desired manner (*e.g.*, in accordance with a program that corresponds to one or more predetermined characters (*e.g.*, letters, numbers, symbols, etc.), patterns, and/or designs; etc.).

A variety of different substrates may be used with such an electronic heated design system. As an example, when the electronic heated design system is used to laminate one material (*e.g.*, reactive foil, etc.) to a sheet of media, the substrate may comprise the sheet of media and a sheet of the reactive foil superimposed over the sheet of media. Alternatively, the substrate may comprise a sheet of a thermally sensitive
30 medium, which may undergo a change in appearance (*e.g.*, color, texture, etc.) when heated to one or more threshold temperatures. As another alternative, the substrate may comprise a sheet of material into which characters, patterns, and/or designs may be melted, etched, burned, etc. (*e.g.*, a thermoplastic film, wood, parchment, etc.).

According to another aspect, a method for decoratively altering a substrate includes securing the substrate to a support mat. The substrate may include a sheet of media and, optionally, a sheet of a material (*e.g.*, reactive foil, etc.) that is to be laminated onto the sheet of media. With the substrate in place, the support mat may be placed
5 beneath a carriage of an electronic cutting and/or drawing system. In addition, a heat pen may be secured to a cradle carried by a carriage of the electronic cutting and/or drawing system. The heating element of the heat pen may be heated to an appropriate temperature by supplying power to the heating element (*e.g.*, by plugging a cable that has been electrically coupled to the heating element into a power source, by moving a switch to an
10 “on” position, etc.). The carriage of the electronic cutting and/or drawing system may then be operated. Operation of the carriage may include bringing a tip of a heating element of the heat pen into contact with the substrate and moving the carriage and, thus, the heat pen, its heating element, and the tip of the heating element over the substrate to decoratively alter the substrate in a desired manner (*e.g.*, with characters, patterns, and/or
15 designs; etc.). In some embodiments, the substrate may also be cut and/or drawn on with a blade and/or pen, respectively, of the electronic cutting and/or drawing system. Once the substrate has been decoratively altered, the support mat may be removed from beneath the carriage, and the substrate may be removed from the support mat.

Other aspects of the disclosed subject matter, as well as features and advantages of
20 the disclosed subject matter, should be apparent to those of ordinary skill in the art through consideration of the foregoing disclosure, the ensuing description and image, and the appended claims.

BRIEF DESCRIPTION OF THE DRAWINGS

25 In the drawings:

FIG. 1 illustrates an embodiment of a heat pen according to this disclosure;

FIG. 2 is a cross-sectional representation of the embodiment of heat pen shown in
FIG. 1;

FIG. 3 is a cross-sectional representation of another embodiment of heat pen
30 according to this disclosure;

FIGs. 4A-4D illustrate various embodiments of adapters capable of use with a
heat pen according to this disclosure; with each embodiment of adapter having a

configuration that enables it to adapt a heat pen for use with a cradle of a particular, corresponding type of electronic cutting and/or drawing system;

FIG. 5 provides a representation of an embodiment of a manner in which an adapter (*e.g.*, the embodiment of adapter shown in FIG. 4A) may be secured to a heat pen
5 (*e.g.*, the embodiment of heat pen shown in FIG. 1);

FIG. 6 illustrates an embodiment of a heat pen with an embodiment of an adapter secured thereto;

FIG. 7 depicts an embodiment of assembly of the embodiment of heat pen-adapter assembly of FIG. 6 with a cradle of an electronic cutting and/or drawing system;

10 FIG. 8 shows the heat pen-adapter assembly of FIG. 6 assembled with the cradle of the electronic cutting and/or drawing system, and illustrates connection of the heat pen to an external power source;

FIG. 9 depicts placement of a protective shield over the tip of the heat pen to limit contact with the tip as it is heated;

15 FIG. 10 illustrates an embodiment of a manner in which a heat pen according to this disclosure may be used with an electronic cutting and/or drawing system to modify a sheet of a medium;

FIG. 11 shows an embodiment of a sheet of a medium that has been modified with a heat pen and an electronic cutting and/or drawing system, such as those depicted by
20 FIG. 10; and

FIG. 12 depicts placement of a protective shield over the tip of the heat pen to limit contact with the tip as it is heated.

DETAILED DESCRIPTION

25 FIGS. 1 and 2 illustrate an embodiment of a heat pen 10. The heat pen 10 includes a housing 11, a power supply 20, and a heating element 40. The housing 11, which may comprise a thermal insulator, carries the power supply 20 and the heating element 40.

The housing 11 of the heat pen 10 may include a head 12, a neck 14, and a body 16. The head 12 of the housing 11, or the top of the housing 11, may have a
30 configuration that enables it to be held by an individual. In some embodiments, the head 12 may be enlarged relative to (*e.g.*, have a larger diameter than, etc.), the neck 14 of the housing 11 and the body 16 of the housing 11. A lower edge 13 of the head 12 may be laterally exposed beyond an outer periphery of the neck 14. As illustrated, the head 12

may be cylindrical in shape, with rounded edges between its circumference and its upper surface.

The neck 14 of the housing 11, which may also be referred to as an intermediate portion of the housing 11, may be immediately adjacent to the head 12 of the housing 11.

5 The neck 14 may include one or more engagement features 15, such as the illustrated helical thread, that enable the neck 14 to engage complementary engagement features 57 (FIGs. 4A-4D) of an adapter 50, 50', 50'', 50''' (FIGs. 4A-4D), as will be described in further detail hereinafter. The neck 14 may have a cylindrical shape.

The body 16 of the housing 11, which comprises a bottom of the housing 11, is
10 located on an opposite side of the neck 14 of the housing 11 from the head 12. The body 16 may have a configuration that enables it to be received by and, optionally, engaged by a cradle 102 (FIGs. 7-10) of an electronic cutting and/or drawing system 100 (FIG. 10). The configuration of the body 16 may enable it to receive or to be received by any of a plurality of different adapters 50, 50', 50'', 50''' (FIGs. 4A-4D), which may
15 enable the heat pen 10 to be assembled with a variety of different electronic cutting and/or drawing systems 100. Additionally, a lower portion of the body 16 may have a configuration that enables the lower portion to protrude from a lower portion of the cradle 102 with which the heat pen 10 and an optional adapter 50, 50', 50'', 50''' are assembled. In the embodiment depicted by FIG. 1, the body 16 of the housing 11 of the
20 heat pen 10 is cylindrical in shape.

The body 16 of the housing 11 may carry the heating element 40 of the heat pen 10, with a tip 42 of the heating element 40 protruding beyond a bottom surface 17 of the body 16.

As illustrated by FIGs. 1 and 2, the power supply 20 of the heat pen 10 may
25 comprise a power cable that may communicate with an external power source 104 (FIG. 8), such as a powered port of an electronic cutting and/or drawing system 100 (FIG. 10) (*e.g.*, a universal serial bus (USB) port, etc.), an electrical outlet, or the like. The power supply 20 may include a plurality of wires 22 and 24 that establish an electrical circuit between the external power source 104 and electronics of the heat
30 pen 10. In particular, the wires 22 and 24 of the power supply 20 may establish an electrical circuit between the external power source 104 and the heating element 40 of the heat pen 10.

The heating element 40 of the heat pen may comprise a resistor, which may generate heat as an electrical current flows through the circuit defined by the external power source 104 (FIG. 8), the wires 22 and 24, and the heating element 40. The resistor of the heating element 40 may be configured to heat the heating element 40 as an electrical current flows through the circuit. The temperature to which the heating element 40 is heated may depend upon the current supplied by the external power source 40. As is known in the art, USB 1.0 and USB 2.0 ports are capable of generating a current of up to about 500 mA (0.5 A), USB 3.0 ports are capable of generating a current of up to about 900 mA, and dedicated charging ports can generate a current of up to about 1,500 mA (1.5 A).

An exterior of at least a portion of the heating element 40 may be capable of conducting heat generated by the resistor of the heating element 40. In the illustrated embodiment, the heating element 40 includes a tip 42 capable of conducting heat generated by the resistor to objects with which the tip 42 is brought into contact. A distance across the tip 42 may define a distance across a feature, such as a diameter of a dot or a thickness of a line, that may be defined by the tip 42 as the tip 42 is heated and brought into contact with an objection, such as a sheet 140 (FIGs. 10 and 11) of a heat-sensitive medium. The heat pen 10 may have a fine tip (*e.g.*, a diameter of up to about 0.8 mm), a standard tip (*e.g.*, a diameter of about 0.9 mm to about 1.3 mm, etc.), or a bold tip (*e.g.*, a diameter of about 1.4 mm or greater). A shape of the tip 42 may at least partially define a shape of a feature that may be defined by the tip 42 as it is heated and brought into contact with an object.

Additionally, an outer periphery of the heating element 40 may comprise and/or be surrounded by a thermal insulator, which may prevent heat generated by the resistor of the heating element 40 from being communicated to the body 16 of the housing 11, or at least limit the transfer of heat from the heating element 40 to the body 16.

In some embodiments, the electrical circuit of a heat pen 10 may include one or more accessories 23 in addition to the wires 22 and 24 and the resistor of the heating element 40. Without limitation, such an accessory 23 may comprise a switch, an auto-shutoff device, a temperature control device, or any combination of the foregoing.

In FIG. 3 another embodiment of heat pen 10' is shown and described. While the housing 11, including the head 12, neck 14, and body 16, of heat pen 11' are similar to or the same as the corresponding features of the housing 11 of the embodiment of heat

pen 10 shown in FIGs. 1 and 2, the electronics of heat pen 10' differ somewhat from the electronics of heat pen 10. In particular, heat pen 10' includes an internal power source 30, such as a battery. In addition, the heat pen 10' includes a charging port 20' (e.g., a USB port, etc.). The charging port 20' communicates with the internal power source 30 in a manner that enables the internal power source 30 to communicate with an external power source (e.g., a USB port, an electrical outlet, a battery, etc.) to enable charging of the internal power source 30. Like the embodiment of heat pen 10 shown in FIGs. 1 and 2, heat pen 10' includes wires 22 and 24 that establish an electrical circuit between the internal power source 30 and a heating element 40 of the heat pen 10'.

Turning now to FIGs. 4A-4D, various embodiments of adapters 50, 50', 50'', 50''', respectively, are depicted. Each adapter 50, 50', 50'', 50''' includes a body 52, 52', 52'', 52''' through which a receptacle 54, 54', 54'', 54''' extends. The receptacle 54, 54', 54'', 54''' may have a shape and dimensions that enable it to receive and slide along a length (or height) of the body 16 (FIGs. 1-3) of a heat pen 10 (FIGs. 1 and 2), 10' (FIG. 3). In embodiments where the body 16 is cylindrical, the receptacle 54, 54', 54'', 54''' may comprise a cylindrical channel extending through the body 52, 52', 52'', 52''' of the adapter 50, 50', 50'', 50'''. At its top end 56, 56', 56'', 56''', a periphery of the receptacle 54, 54', 54'', 54''' may include or define one or more engagement features 57, 57', 57'', 57''', which may have a configuration capable of engaging, being engaged by, or mutually engaging the one or more engagement features 15 of the neck 14 of the housing 11 of the heat pen 10, 10'. In the illustrated embodiment, the engagement features 57, 57', 57'', 57''' comprise helical threads that may complement the thread of the embodiment of engagement feature 15 shown in FIGs. 1-3. Of course, other types of engagement features may be used in place of helical threads, such as complementary surfaces that establish an interference fit, snap-fitting features, interlocking features, and the like.

An exterior of the body 52, 52', 52'', 52''' of each adapter 50, 50', 50'', 50''' may have a configuration that enables the adapter 50, 50', 50'', 50''' and a heat pen 10, 10' with which the adapter 50, 50', 50'', 50''' is assembled to be coupled with a cradle 102 (FIGs. 7-10) of an electronic cutting and/or drawing system 100 (FIG. 10). The configuration of the exterior of the body 52, 52', 52'', 52''' of the adapter 50, 50', 50'', 50''' may complement a shape of a receptacle of a cradle 102 of an electronic cutting and/or drawing system 100 with which the adapter 50, 50', 50'', 50''' is capable of use, which

may enable the adapter 50, 50', 50'', 50''' to be received and stably held by the receptacle of the cradle 102.

The body 52 of the adapter 50 shown in FIG. 4A has a configuration that enables a heat pen 10 (FIGs. 1 and 2), 10' (FIG. 3) to be coupled with the cradle 102 (FIGs. 7-10) of a SILHOUETTE electronic cutting and/or drawing system 100 (FIG. 10) (available from Silhouette America, Inc., of Lindon, Utah). FIG. 4B illustrates an embodiment of adapter 50' with a configuration that enables coupling of a heat pen 10, 10' to a cradle 102 of a BROTHER electronic cutting and/or drawing system 100 (available from Brother International Corporation of Bridgewater, New Jersey). FIG. 4C depicts an embodiment of adapter 50'' capable of assembly with a heat pen 10, 10' in a manner that enables the heat pen 10, 10' to be coupled with a cradle 102 of a CRICUT electronic cutting and/or drawing system 100 (available from Provo Craft & Novelty, Inc., of South Jordan, Utah). The embodiment of adapter 50''' shown in FIG. 4D can be assembled with a heat pen 10, 10' to enable the heat pen 10, 10' to couple to a cradle 102 of a SIZZIX electronic cutting and/or drawing system 100 (available from Ellison Educational Equipment of Lake Forest, California).

As illustrated by FIG. 5, the body 16 of the housing 11 (FIGs. 1 and 2) of a heat pen 10 may be introduced into the top end 56 (FIG. 4A) of the receptacle 52 (FIG. 4A) of an adapter 50 until the top end 56 reaches the neck 14 of the housing 11. Upon introducing the neck 14 of the housing 11 of the heat pen 10 into the top end 56 of the receptacle 52 of the adapter 50, engagement features 15, 57 of one or both of the neck 14 and the top end 56 may couple the adapter 50 to the heat pen 10. In the embodiment depicted by FIG. 5, the neck 14 of the housing 11 of the heat pen 10 and the top end 56 of the receptacle 52 of the adapter 50 may include complementary helical threads, which may engage one another as one or both of the adapter 50 and the heat pen 10 is rotated relative to the other of these apparatuses. FIG. 6 shows the adapter 50 assembled with the heat pen 10.

Turning next to FIGs. 7-9, an embodiment of a manner in which a heat pen 10 may be assembled with the cradle 102 of an electronic cutting and/or drawing system 100 (FIG. 10) is depicted. Without limitation, the heat pen 10 may be assembled with a cradle 102 that is configured to receive, carry, and move a cutting blade or a cradle that is configured to receive, carry, and move a writing and/or drawing instrument. In FIG. 7, the tip 42 of the heating element 40 (FIG. 2) of the heat pen 10 is oriented toward the

cradle 102, and the heat pen 10 and any adapter 50 assembled therewith are coupled to the cradle 102 (*e.g.* by introduction thereof into a receptacle of the cradle 102, etc.).

FIG. 8 illustrates coupling of a coupling element 28 (*e.g.*, a USB connector, etc.) of the power supply 20 of the heat pen 10 to a power source 104, such as a powered port (*e.g.*, a USB port, etc.) of the electronic cutting and/or drawing system 10. In some embodiments, such as that depicted by FIG. 9, a protective cover 120 may be placed over the tip 42 of the heating element 40 while the heating element 40 is heated but not in use to prevent inadvertent contact with the tip 42 of the heating element 40 and, thus, any damage that might result from inadvertent contact with the tip 42.

FIG. 10 depicts an embodiment of an electronic heated design system, which may include an electronic cutting and/or drawing apparatus 100 and a heat pen 10 according to this disclosure. Alternatively, an electronic heated design system may include a carriage capable of moving a tip of an integrated heating element into contact with and over selected locations of a substrate.

As illustrated by FIG. 10, a substrate 130, 140 that is to be modified by use of a heat pen 10 may be positioned on a support mat 110 capable of use with an electronic cutting and/or drawing system 100. Once the substrate 130, 140 has been positioned on the support mat 110, it may be secured to the support mat 110. In the specific embodiment depicted by FIG. 10, substrate 130 may comprise a sheet of a substrate medium (*e.g.*, paper, cardstock, bookboard, vinyl, acetate, vellum, fabric, leather, wood, etc.) to which a laminating medium (*e.g.*, a heat-activated foil, etc.) is to be laminated, and substrate 140 may comprise a sheet of the laminating medium or a sheet that carries the laminating medium. Substrate 130 may be secured to the support mat 110. Substrate 140 (which may be provided in or trimmed to a desired design size) may be placed in a desired position over substrate 130, and secured to substrate 130 (*e.g.*, with a suitable adhesive tape 150 positioned over and extending laterally beyond edges of substrate 140, etc.). The support mat 110 may then be prepared for use with (*e.g.*, introduced into, etc.) the electronic cutting and/or drawing system 100.

With the tip 42 of the heating element 40 (FIG. 2) of the heat pen 10 heated to a desired temperature (*e.g.*, a temperature suitable for laminating the laminating medium of substrate 140 to the substrate medium of substrate 130, etc.), any protective cover 120 (FIG. 9) shielding the tip 42 may be removed therefrom, and the electronic cutting and/or drawing system 100 may be used in a known manner (*e.g.*, in accordance with its

operating instructions under control of an appropriate scalable vector graphics (SVG or .svg) file, etc.) to cause a carriage for the cradle 102 and, thus, the tip 42 of the heating element 40 of the heat pen 10 to contact the substrate 140 at selected locations. As the tip 42 of the heating element 40 contacts the substrate 140, laminating medium may be transferred from substrate 140 to substrate 130 to modify substrate 130 in a desired manner (*e.g.*, with design features, such as text, a pattern, a design, an image, etc.), such as the modification 145 depicted by FIG 11. Alternatively, the heat pen 10 may be used with an electronic cutting and/or drawing system to directly modify a substrate 130, 140 (*e.g.*, burn design features into a substrate (*e.g.*, paper, cardstock, bookboard, vellum, leather, wood, etc.), melt design features into a substrate (*e.g.*, vinyl, acetate, etc.), remove material from a substrate to define design features, etc.). The substrate(s) 130, 140 may then be removed from the support mat 110 (FIG. 10), and a protective cover may be placed over the tip 42 of the heating element 40 of the heat pen 10 and/or power to the heating element 40 may be shut off. The heat pen 10 may be disassembled from the cradle 102 of the electronic cutting and/or drawing system 10.

Although the foregoing description sets forth many specifics, these should not be construed as limiting the scope of any of the claims, but merely as providing illustrations of some embodiments and variations of elements or features of the disclosed subject matter. Other embodiments of the disclosed subject matter may be devised which do not depart from the spirit or scope of any of the claims. Features from different embodiments may be employed in combination. Accordingly, the scope of each claim is limited only by its plain language and the legal equivalents thereto.

CLAIMS

What is claimed:

1. An insert for an electronic cutting and/or drawing system, comprising:
a housing insertable into a cradle of the electronic cutting and/or drawing system;
5 a heating element carried by the housing, the heating element including a tip protruding
from a bottom of the housing; and
a power supply.
2. The insert of claim 1, wherein the housing is elongated.
10
3. The insert of claim 1 or claim 2, further comprising:
an adapter capable of being positioned at least partially around the housing capable of
adapting the housing for insertion into a cradle of a particular type of electronic
cutting and/or drawing system.
15
4. The insert of claim 3, comprising a plurality of adapters capable of
adapting the housing for insertion into cradles of a corresponding plurality of different
types of electronic cutting and/or drawing systems.
- 20 5. The insert of any of claims 1-4, wherein the tip of the heating element is
rounded.
6. The insert of any of claims 1-4, wherein the tip of the heating element is
beveled.
25
7. The insert of any of claims 1-6, wherein the heating element is capable of
heating the tip to a temperature capable of laminating a reactive foil onto a substrate.
8. The insert of any of claims 1-6, wherein the heating element is capable of
30 heating the tip to a temperature suitable for wood burning.
9. The insert of any of claims 1-8, wherein the power supply comprises a
power cable.

10. The insert of claim 9, wherein the power cable is capable of being plugged into at least one the electronic cutting and/or drawing system, a computer with which the electronic cutting and/or drawing system is used, an adapter for an electrical outlet, and/or
5 an electrical outlet.

11. The insert of claim 9, wherein the power supply comprises a universal serial bus (USB) type connector.

10 12. A system for decoratively modifying a substrate, comprising:
an electronic heated design system including:
a support mat capable of receiving and supporting the substrate;
a heating element with a tip;
a carriage capable of positioning the tip of the heating element in selected
15 locations over the support mat;
a processor in communication with the carriage and capable of controlling
operation of the carriage to move the heating element to the selected
locations; and
memory in communication with the processor, the memory storing instructions for
20 controlling operation of the carriage; and
a substrate capable of being positioned on the support mat.

13. The system of claim 12, wherein the substrate comprises a reactive foil and a sheet of media onto which the reactive foil is capable of being transferred.
25

14. The system of claim 13, wherein the reactive foil and the sheet of media are superimposed over one another.

15. The system of claim 12, wherein the substrate comprises a sheet of wood.
30

16. The system of any of claims 12-15, wherein the electronic heated design system comprises an electronic cutting and/or drawing system.

17. The system of claim 16, wherein:
the electronic heated design system comprises a cradle capable coupled to the carriage,
the carriage capable of positioning the cradle in selected locations over the support
mat; and
- 5 the heating element is a heating element of a heat pen capable of being introduced into the
cradle, the heat pen including a housing and the heating element carried by the
housing, the heating element including a tip protruding from a bottom of the
housing.
- 10 18. The system of claim 17, further comprising:
an adapter capable of assembly with the housing of the heat pen, the adapter capable of
adapting the heat pen to be received by and secured within the cradle of the
electronic heated design system.
- 15 19. A method for laminating foil onto a sheet of media, comprising:
securing the sheet of media and a sheet of reactive foil in superimposed relation on a
support mat of an electronic cutting and/or drawing system;
placing the support mat, the sheet of media, and the sheet of reactive foil beneath a
carriage of the electronic cutting and/or drawing system;
- 20 securing a heat pen to a cradle carried by the carriage of the electronic cutting and/or
drawing system;
heating a tip of a heating element of the heat pen; and
operating the carriage of the electronic cutting and/or drawing system, including:
bringing the tip of the heating element into contact with the reactive foil; and
- 25 moving the cradle and the heat pen over the sheet of reactive foil to transfer
reactive foil from the sheet of reactive foil to the sheet of media in a
desired manner;
removing the support mat from beneath the carriage of the electronic cutting and/or
drawing system;
- 30 removing the reactive foil from the sheet of media; and
removing the sheet of media from the support mat.

20. The method of claim 19, further comprising:
plugging the heat pen into a power source.

21. The method of claim 20, wherein plugging the heat pen into a power
5 source comprises plugging a cable of the heat pen into a power supply port of the
electronic cutting and/or drawing system.

22. The method of any of claims 19-21, further comprising:
securing a blade to the cradle; and
10 before removing the support mat and removing the sheet of media, operating the carriage
of the electronic cutting and/or drawing system, including:
bringing a tip of the blade into contact with the sheet of media; and
moving the cradle and the blade over the sheet of media to cut the sheet of media
in a desired manner.

15

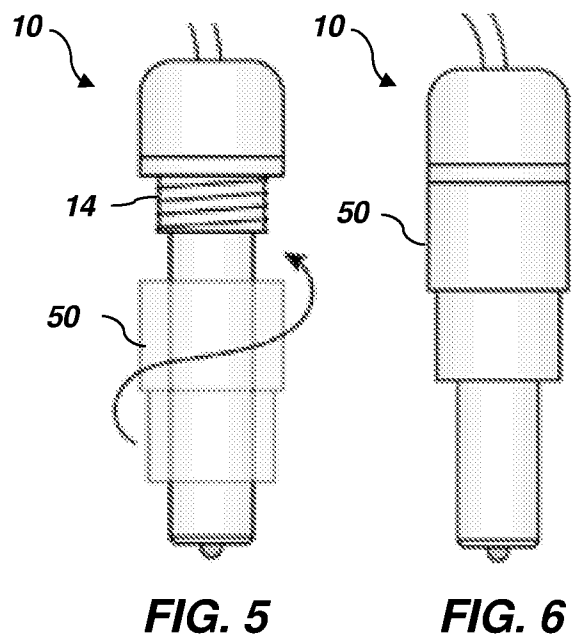
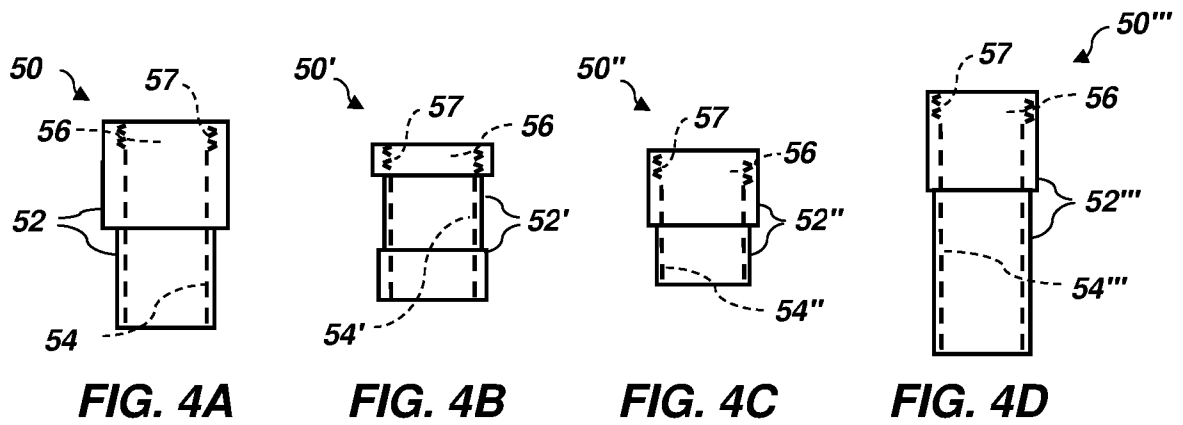
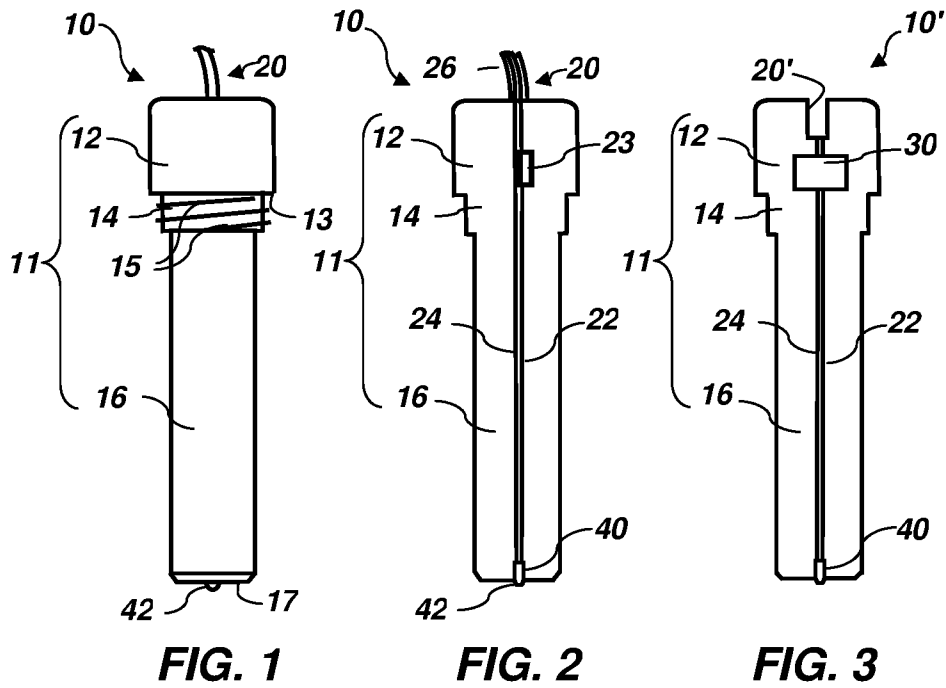

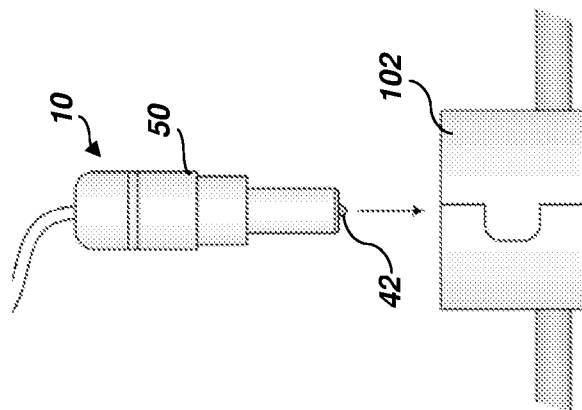

FIG. 7

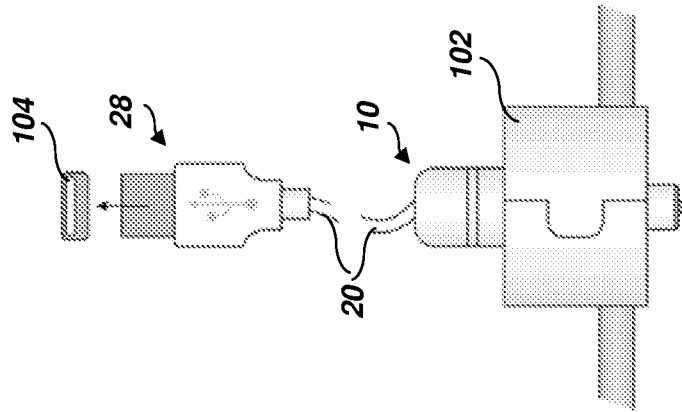

FIG. 8

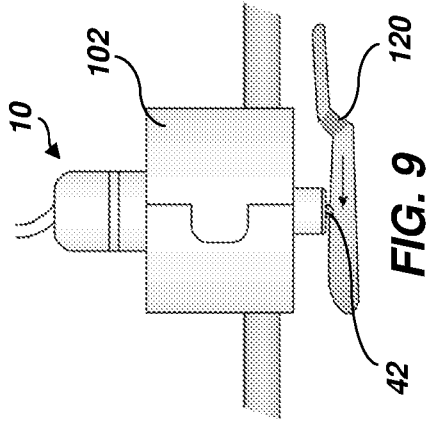

FIG. 9

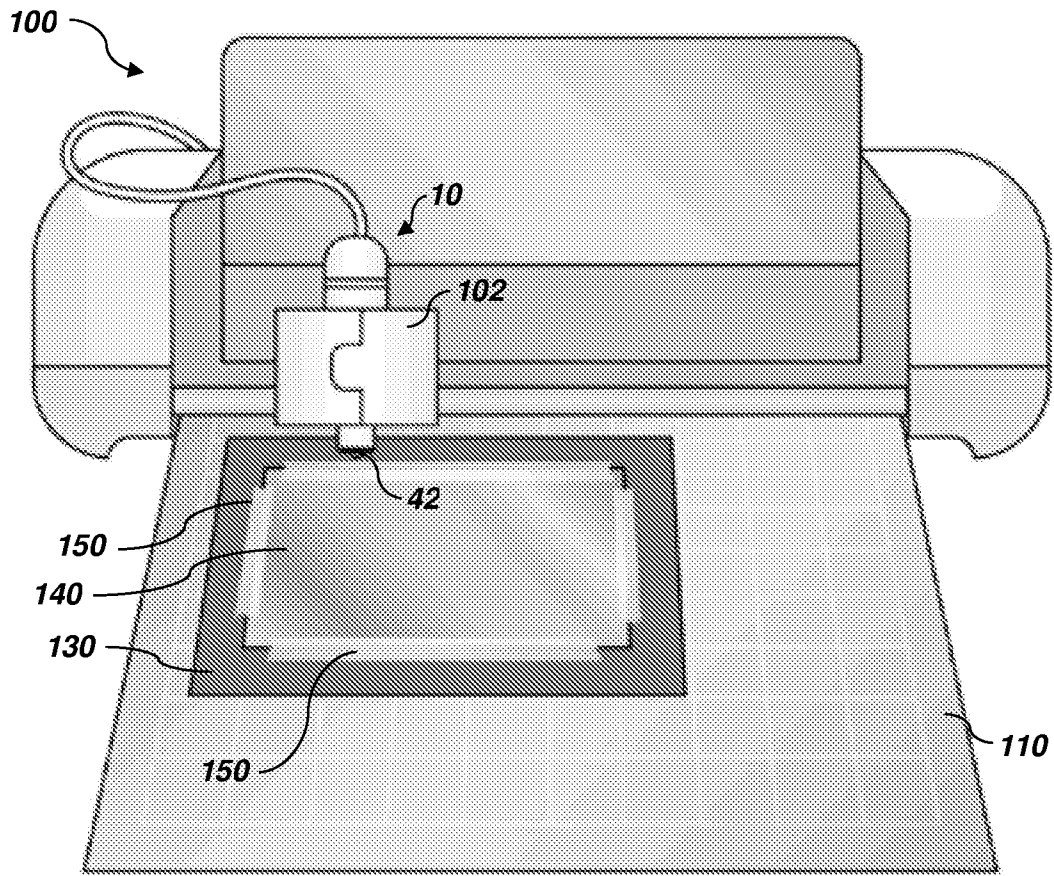

FIG. 10

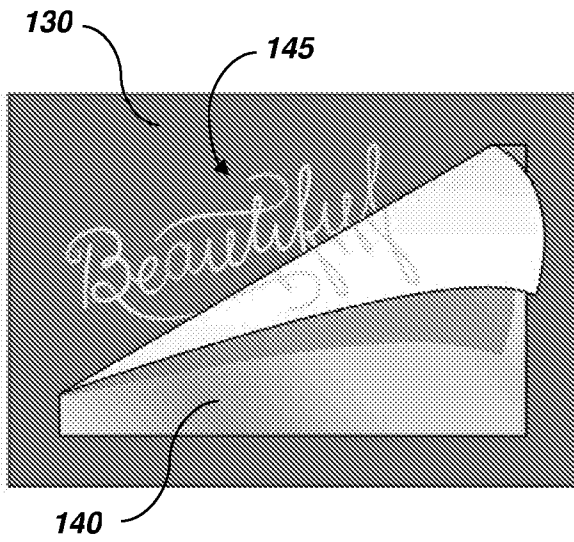

FIG. 11

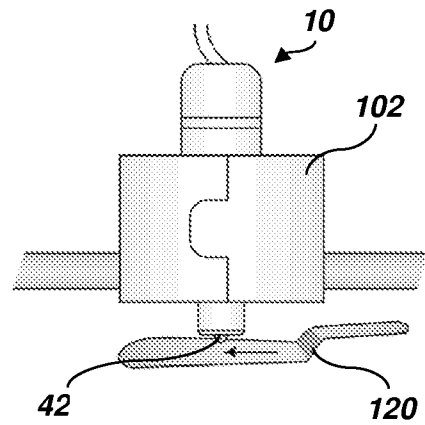

FIG. 12

INTERNATIONAL SEARCH REPORT

International application No.

PCT/US19/12945

Box No. II Observations where certain claims were found unsearchable (Continuation of item 2 of first sheet)

This international search report has not been established in respect of certain claims under Article 17(2)(a) for the following reasons:

1. Claims Nos.:
because they relate to subject matter not required to be searched by this Authority, namely:

2. Claims Nos.:
because they relate to parts of the international application that do not comply with the prescribed requirements to such an extent that no meaningful international search can be carried out, specifically:

3. Claims Nos.: 5-11
because they are dependent claims and are not drafted in accordance with the second and third sentences of Rule 6.4(a).

Box No. III Observations where unity of invention is lacking (Continuation of item 3 of first sheet)

This International Searching Authority found multiple inventions in this international application, as follows:

1. As all required additional search fees were timely paid by the applicant, this international search report covers all searchable claims.
2. As all searchable claims could be searched without effort justifying additional fees, this Authority did not invite payment of additional fees.
3. As only some of the required additional search fees were timely paid by the applicant, this international search report covers only those claims for which fees were paid, specifically claims Nos.:

4. No required additional search fees were timely paid by the applicant. Consequently, this international search report is restricted to the invention first mentioned in the claims; it is covered by claims Nos.:

- Remark on Protest**
- The additional search fees were accompanied by the applicant's protest and, where applicable, the payment of a protest fee.
 - The additional search fees were accompanied by the applicant's protest but the applicable protest fee was not paid within the time limit specified in the invitation.
 - No protest accompanied the payment of additional search fees.

INTERNATIONAL SEARCH REPORT

International application No.

PCT/US19/12945

A. CLASSIFICATION OF SUBJECT MATTER
 IPC - B44B 3/06, 7/00; B44C 1/02, 1/14 (2019.01)
 CPC - B44B 1/006, 3/063, 7/007; B44C 1/02, 1/02, 1/14

According to International Patent Classification (IPC) or to both national classification and IPC

B. FIELDS SEARCHED

Minimum documentation searched (classification system followed by classification symbols)

See Search History document

Documentation searched other than minimum documentation to the extent that such documents are included in the fields searched

See Search History document

Electronic data base consulted during the international search (name of data base and, where practicable, search terms used)

See Search History document

C. DOCUMENTS CONSIDERED TO BE RELEVANT

Category*	Citation of document, with indication, where appropriate, of the relevant passages	Relevant to claim No.
X --- Y	US 4,594,499 A (RAPSEY, C. et al.) 10 June 1986; figures 3, 5-8; column 5, lines 40-61; column 6, line 1 - column 7, lines 1-58; column 8, lines 18-10; column 8, line 62 - column 9, line 17	1-3, 12, 15, 16/12, 16/15, 17/16/12, 17/16/15, 18/17/16/12, 18/17/16/15
X --- Y	JP H 11216998 A (HONMA, A.) 10 August 1999; paragraphs 0009-0011; figures 1-2	12-14, 16/12-16/14, 17/16/12-17/16/14, 19
A	US 3,691,901 A (SHELTON, J. D.) 19 September 1972; figures 1, 4, 4A; column 3, lines 50-55; column 6, lines 5-17, 64-66	1-3
A	JP 2008/279664 A (YAMAMOTO, H.) 20 November 2008; abstract; paragraphs [0015]-[0016], [0022]; figures 1-2, 4	1-3
A	US 2002/0092396 A1 (HSIAO, C. T.) 18 July 2002; entire document	1-2, 3/1-3/2, 4/3/1-4/3/2, 12-15, 16/12-16/15, 17/16/12-17/16/15, 18/17/16/12-18/17/16/15, 19-21, 22/19-22/21



Further documents are listed in the continuation of Box C.



See patent family annex.

* Special categories of cited documents:

"A" document defining the general state of the art which is not considered to be of particular relevance

"E" earlier application or patent but published on or after the international filing date

"L" document which may throw doubts on priority claim(s) or which is cited to establish the publication date of another citation or other special reason (as specified)

"O" document referring to an oral disclosure, use, exhibition or other means

"P" document published prior to the international filing date but later than the priority date claimed

"T" later document published after the international filing date or priority date and not in conflict with the application but cited to understand the principle or theory underlying the invention

"X" document of particular relevance; the claimed invention cannot be considered novel or cannot be considered to involve an inventive step when the document is taken alone

"Y" document of particular relevance; the claimed invention cannot be considered to involve an inventive step when the document is combined with one or more other such documents, such combination being obvious to a person skilled in the art

"&" document member of the same patent family

Date of the actual completion of the international search

08 March 2019 (08.03.2019)

Date of mailing of the international search report

27 MAR 2019

Name and mailing address of the ISA/

Mail Stop PCT, Attn: ISA/US, Commissioner for Patents
 P.O. Box 1450, Alexandria, Virginia 22313-1450
 Facsimile No. 571-273-8300

Authorized officer

Shane Thomas

PCT Helpdesk: 571-272-4300
 PCT OSP: 571-272-7774

INTERNATIONAL SEARCH REPORT

International application No.

PCT/US19/12945

C (Continuation). DOCUMENTS CONSIDERED TO BE RELEVANT

Category*	Citation of document, with indication, where appropriate, of the relevant passages	Relevant to claim No.
A	US 6,119,567 A (SCHINDLER, M. S. et al.) 19 September 2000; entire document	1-2, 3/1-3/2, 4/3/1-4/3/2, 12-15, 16/12-16/15, 17/16/12-17/16/15, 18/17/16/12-18/17/16/15, 19-21, 22/19-22/21
A	US 4,056,136 A (MILLER, D. M.) 01 November 1977; entire document	1-2, 3/1-3/2, 4/3/1-4/3/2, 12-15, 16/12-16/15, 17/16/12-17/16/15, 18/17/16/12-18/17/16/15, 19-21, 22/19-22/21
A	CN 105291671 A (WU, G.) 03 February 2016; entire document	1-2, 3/1-3/2, 4/3/1-4/3/2, 12-15, 16/12-16/15, 17/16/12-17/16/15, 18/17/16/12-18/17/16/15, 19-21, 22/19-22/21
A	CN 104404734 A (FU, S.) 11 March 2015; entire document	1-2, 3/1-3/2, 4/3/1-4/3/2, 12-15, 16/12-16/15, 17/16/12-17/16/15, 18/17/16/12-18/17/16/15, 19-21, 22/19-22/21