

A. L. UNDELAND.

BARBER CHAIR.

APPLICATION FILED MAY 27, 1908.

Patented July 11, 1911.

4 SHEETS-SHEET 2.

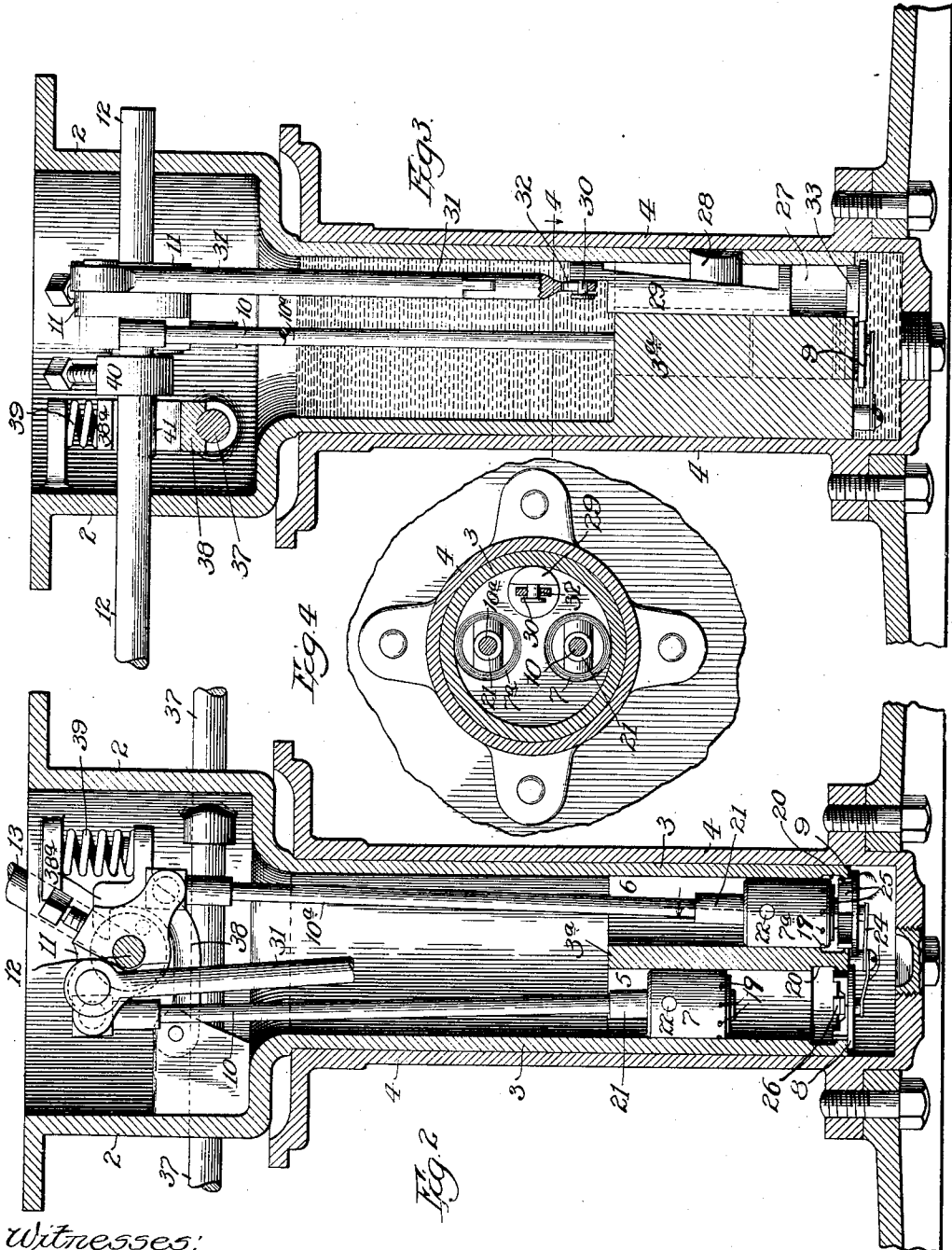

Witnesses:
Irving Mac Donald
McHolland Young.

Inventor:
Andrew L. Undeland.
By Barton, Tammen & Falk,
Attys.

A. L. UNDELAND.

BARBER CHAIR.

APPLICATION FILED MAY 27, 1908.

Patented July 11, 1911.

4 SHEETS-SHEET 3.

997,937.

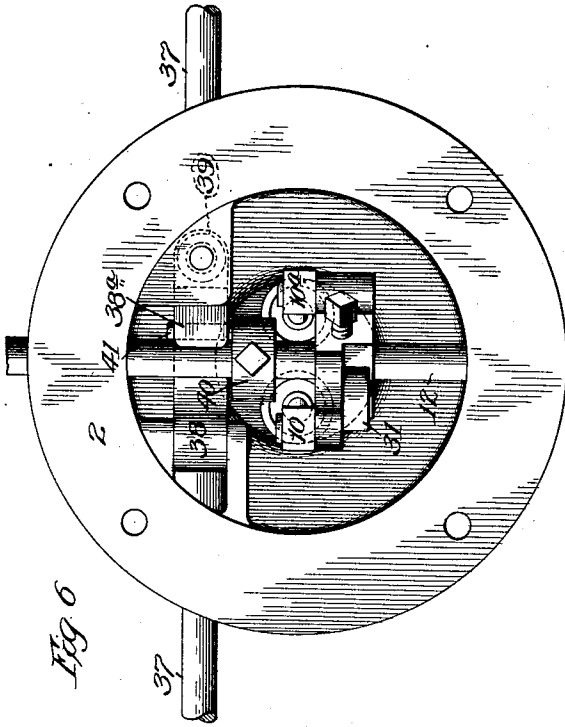

Fig. 6

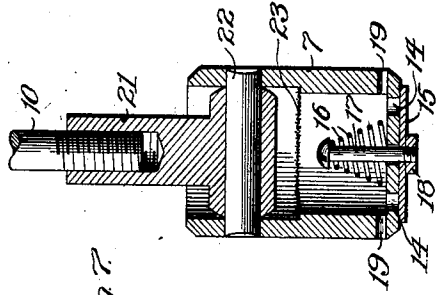

Fig. 7

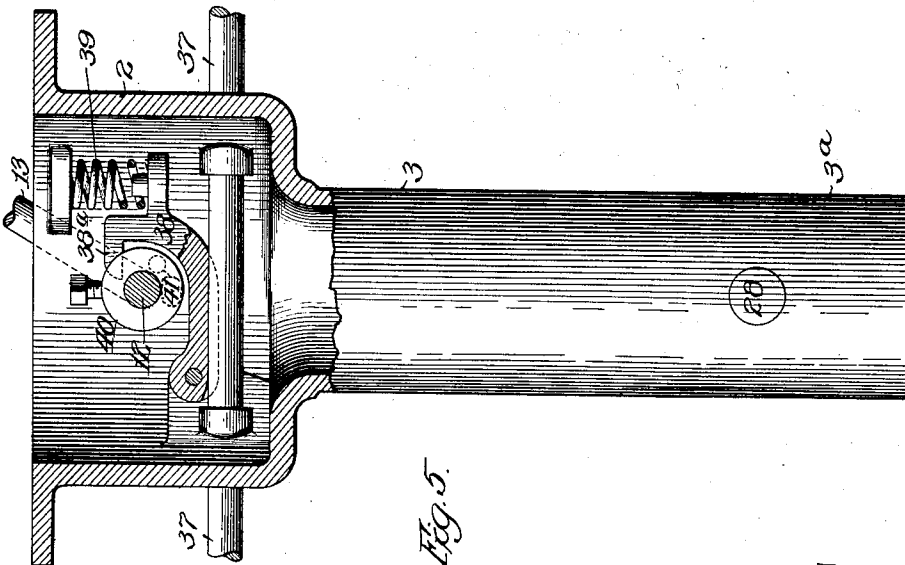

Fig. 5

Witnesses:
 Irving Mac Donald
 McCalland Young.

Inventor
 Andrew I. Undeland
 By Barton, Tanner & Folk.
 Att'ys

A. L. UNDELAND.
BARBER CHAIR.

APPLICATION FILED MAY 27, 1908.

Patented July 11, 1911.

4 SHEETS—SHEET 4.

997,937.

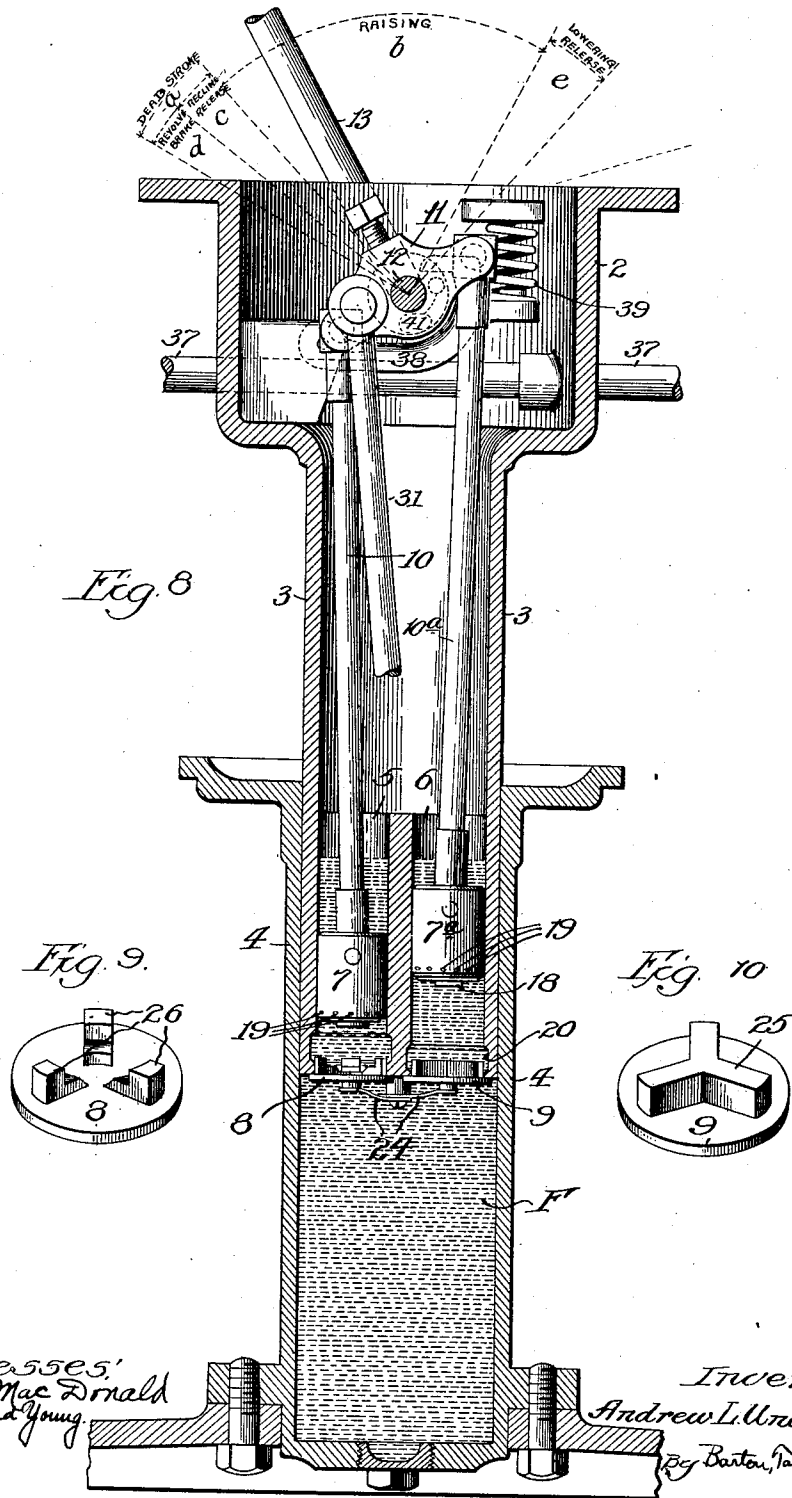

Witnesses:
Irving Mac Donald
M. Belland Young

Inventor:
Andrew L. Undeland
By Barton, Tamm & Falk
Attorneys

UNITED STATES PATENT OFFICE.

ANDREW L. UNDELAND, OF OMAHA, NEBRASKA.

BARBER-CHAIR.

997,937.

Specification of Letters Patent.

Patented July 11, 1911.

Application filed May 27, 1908. Serial No. 435,199.

To all whom it may concern:

Be it known that I, ANDREW L. UNDELAND, a citizen of the United States, residing at Omaha, in the county of Douglas and State of Nebraska, have invented a certain new and useful Improvement in Barber-Chairs, of which the following is a full, clear, concise, and exact description.

My invention relates to chairs and more particularly to chairs of the revolving and reclining type, such as are used by barbers and dentists, in which the seat is adjustable vertically by hydraulic pressure.

My invention has for its object the provision of means whereby the chair seat may be rapidly and easily raised or lowered, may be made either revoluble or non-revoluble, and may be readily adjusted to different reclining positions, all by the manipulation of a single controlling lever.

My invention contemplates a cylinder in which a hollow piston reciprocates, said piston being provided with double acting pump-pistons arranged to control the flow of a fluid from the piston into the cylinder or vice versa, and thus either raise or lower the piston and the chair seat carried upon the upper end thereof. The pump-pistons are connected to a crank arm which is operated from a handle. The crank arm has also connected with it means for controlling the revolving of the piston in the cylinder and additional means for controlling the reclining adjustment of the chair seat. Thus by the manipulation of a single crank, the chair may be raised, held in a raised position, lowered, made revolving or non-revolving, and adjusted to different reclining positions.

The several features of my invention may be more readily understood by reference to the accompanying drawings, in which—

Figure 1 is a side elevation of a chair embodying my invention, the dotted lines indicating one of the reclining positions to which the chair may be adjusted; Fig. 2 is a vertical central section through cylinder and piston, showing the piston in its lowermost position, prepared to receive the oil or other charging fluid; Fig. 3 is a view similar to that of Fig. 2 taken at right angles thereto, and showing by dotted lines the fluid in the hollow piston and cylinder; Fig. 4 is a plan sectional view on the line 4 of Fig. 3; Fig. 5 is a side elevation of the

hollow piston partly in section, showing the locking means for controlling the reclining position of the chair; Fig. 6 is a plan view of the hollow piston; Fig. 7 is a detail longitudinal section of the pump-piston; Fig. 8 is a vertical central section, similar to that of Fig. 2, but showing the hollow piston held in its raised position; Fig. 9 and Fig. 10 are perspective views of the two valves controlling the ports in the head of the hollow piston.

Like parts are designated by similar characters of reference throughout the different views.

The chair seat 1 is mounted in the usual manner upon the enlarged upper end 2 of the hollow piston 3, which reciprocates in the hollow cylinder 4, rigidly mounted on a suitable base.

The lower end of the hollow piston 3 consists of a solid head 3^a provided with two parallel longitudinally extending wells 5, 6, in which similar pump-pistons 7, 7^a reciprocate. The bottoms of the wells 5, 6 are provided with valves 8, 9, respectively, the object of such arrangement being to provide a double acting pump by which oil or other fluid F can be pumped from the hollow piston 3 into the cylinder 4 and thus elevate the piston 3.

The pump-pistons 7, 7^a are connected by piston-rods 10, 10^a with the opposite ends of a crank 11. The crank 11 is fixed upon a crank shaft 12, which has bearings in the enlarged upper-end 2 of the hollow piston. The crank shaft 12 is provided with an operating lever or handle 13.

The pump-pistons 7, 7^a are of similar construction. As shown in detail in Fig. 7, the pump-piston consists of a cup or shell having holes 14 in the bottom thereof, which are normally closed by a disk-valve 15, held against the bottom of the shell by the tension of a coiled spring 16 which surrounds the bolt 17, the nut 18 upon the end of said bolt holding said disk 15 upon the outer end of the bolt. The sides of the pump-piston, near the bottom thereof, are provided with a plurality of holes 19. Each pump-piston fits tightly in its corresponding well 5 or 6, and hence the holes 19 are thus normally closed. But the wells 5, 6, are enlarged at the bottom portions as at 20, 20, so that at the extreme downward stroke of the pump-pistons the holes 19, 19

are open and the fluid can flow freely from the bottom of the well through the holes 19 into the interior of the pump-pistons 7, 7^a, for reasons which will hereinafter be set forth.

Each piston rod 10, 10^a terminates in a wrist-link 21, which in turn carries a wrist pin 22, pivotally connected in the pump-piston. The link 21 at its bottom portion extends diametrically across the interior of the pump piston 7 or 7^a, leaving a space upon each side for the flow of the oil—see Fig. 4. The interior of the hollow pump-piston is divided transversely by a strainer 23, thereby preventing any dirt in the oil from passing down and clogging the lower oil passages, or interfering with the proper operation of the several valves.

As before stated, the bottoms of the wells 5, 6 are provided with disk valves 8, 9, respectively, held in their seats by flat springs 24, 24. The inner face of the disk 9 is provided with a spider-shaped upstanding rib 25 the ends of which form guides to hold said disk against lateral displacement. In the extreme lowered position of the pump-piston 7^a, the nut 18 rests upon said rib 25 and holds the valve 9 open, as shown in Fig. 2.

The disk valve 8 is provided upon its inner face with upstanding concentrically arranged lugs 26 forming guides for said disk. It will be observed that, with this construction, when the pump-piston 7 is in its lowermost position, the nut 18 upon the bottom of said pump-piston rests in the hollow between the lugs 26, and hence does not positively hold the valve 8 in an open position.

A vertical hole 27 is drilled in the piston head 3^a. Projecting from said hole through the exterior wall thereof and bearing against the inner wall of the cylinder 4 is a slidable plug or plunger 28. The inner end of said plug is beveled and bears against the oppositely beveled or wedge shaped block 29, which reciprocates in the hole 27. Said block 29 is cut away on the side adjacent to the plug 28 to form a wedge shaped bearing surface. The upper end of the block 29 is pivotally connected by a pin 30 with the lower end of a pitman 31. The upper end of said pitman is pivotally connected to one end of the crank 11.

When the crank 11 is operated so as to force the block 29 in its lowermost position, the wedge-shaped surface of said block presses the plunger 28 into engagement with the cylinder 4 and thus locks the piston 3 against revolving in the cylinder 4. The pin 30 extends through a short longitudinal slot 32 in the lower end of the pitman 30, thus allowing for loose play and permitting a slight elevation of the pitman after the block 29 has been moved into locking position without a consequent movement of said

block 29, the reason for which will hereinafter more fully appear. The bottom of the hole 27 may be closed by a plug 33.

In order that at the time the lever handle 13 is being moved into position to lock the chair against revolution there may not be any strain on the parts due to the tendency of the stroke to elevate the piston 3, I have provided for a dead-stroke of the handle 13. Such dead-stroke is within the arc indicated by the angle a in Fig. 8. During the movement of the handle 13 within the limits of the angle indicated, the holes 19 in the pump-piston 7 are opposite the enlargement 20, and the fluid beneath the piston 7 is free to flow through said openings. Thus the valve 8 under such conditions is not subjected to sufficient pressure to open the same and force more fluid beneath the piston head 3^a. It will be seen, therefore, that the stroke of the handle which locks the chair against revolution is a dead stroke so far as pumping is concerned.

The system of levers by which the chair back 34, arms 35, and foot rest 36 are made adjustable to different reclining positions is old and well-known, and needs no description and, moreover, is clearly shown in Fig. 1. Said parts are held in their adjusted positions by means of a rod 37 which passes transversely through the upper end 2 of the piston. Pivoted at one end upon the interior of the upper end 2 of the piston is a brake-shoe 38, which straddles and bears upon the rod 37 and is normally held in close frictional engagement therewith by means of a coiled spring 39, the tension of said spring being downward upon the free end of the brake-shoe 38. Said rod is thus normally locked against movement and in turn locks the chair in any reclining position to which it may have been adjusted. As a means for releasing the rod 37, I provide upon the crank-shaft 12 a collar 40 which carries a laterally projecting pin 41. The brake shoe 38 is provided at its free end with a hook or lug 38^a which projects in the path of movement of said pin 41. Thus by rotating the crank shaft 12, through manipulation of the handle 13, sufficiently for the pin to engage beneath said hook 38^a and lift the same, the tension of the spring 39 is overcome and the rod 37 is released; whereupon the chair back may be adjusted to any desired position.

The work performed during the different operating positions of the lever handle 13 may now be understood.

Referring to Fig. 8, the handle is reciprocated between the positions indicated by the angle b , one of the pump-pistons 7, 7^a is being raised, thereby causing the pressure of the fluid above said pump-piston to open the valve 15 and admit the fluid beneath the same. The other pump-piston, being on its

downward stroke, has its valve 15 closed and the pressure exerted opens the corresponding valve 8 or 9, thus forcing the fluid beneath the piston 3 and elevating the same.

5 Meanwhile the piston 3 is free to revolve in the cylinder 4. If it is desired to adjust the reclining position of the chair, the handle is moved through the arc indicated by the angle *c*. This being part of the dead stroke, the chair is not elevated, thereby such stroke merely releasing the brake shoe 38 from engagement with the rod 37 to permit the adjustment of the chair, as heretofore described. If it is desired to lock the chair against revolution, the handle 13 is moved to the extreme left, as indicated in Fig. 5, through the arc of the angle *d*. The wedge 29 is thus forced downward to lock the parts against rotation. Upon the release of the handle 13 the pressure of the spring 39 exerted through the hook 38^a upon the pin 41 returns the handle to the upper limit of the angle *c*, such return, owing to the lost motion due to the loose connection at the slot 30 (see Fig. 3) not releasing the wedge or block 29. When it is desired to lower the chair, the handle 13 is moved to the extreme right in Fig. 8, through the arc of the angle *e*. This brings the pump-piston 7^a in contact with the rib 25 on the valve 9, and holds said valve open. The fluid is thus free to flow from the cylinder 4 around the open valve 9 into the bottom of the well 6, through the openings 19 in the pump-piston 7^a into the hollow piston 3. The chair is thus being gradually lowered as the fluid flows from the cylinder 4 into the hollow piston 3.

It will be noted that I have provided a double acting pump, whereby both the forward and return stroke of the operating handle may serve to elevate the chair, thus distributing the power required for said operation; that in combination with such double acting pump I am enabled to provide, through the operation of a single crank, means for raising the chair, holding it in its raised position, adjusting the reclining position of the chair, regulating said chair so that it becomes revoluble or non-revoluble, and lowering the chair as may be desired.

I claim:

1. In a chair, the combination with a hollow cylinder, of a hollow piston reciprocating therein, a chair seat mounted upon the outer end of said hollow-piston, a double-acting pump, carried within said hollow-piston, for pumping fluid from said hollow-piston through the piston head into the cylinder and thus elevating the chair, valves operated by said double acting pump for controlling the flow of fluid between said hollow cylinder and hollow piston, means for providing a dead stroke during the limit

of the downward movement of one of said double acting pumping elements, and means for positively holding open the valve controlled by the other pumping element at the limit of its extreme downward movement.

2. In a chair, the combination with a hollow cylinder, of a hollow piston reciprocating therein, said piston being provided with two parallel longitudinally extending wells, double-acting pump mechanism, carried within said hollow-piston, for pumping fluid from said wells into said cylinder, and thus elevating said hollow piston, downwardly opening-valves at the bottom of said wells, means for providing a dead stroke during the extreme downward movement of one of the pumping elements, and means for positively holding open the valve controlled by the other pumping element at the limit of its extreme downward movement.

3. In a chair, the combination with a vertically mounted hollow cylinder, of a hollow piston telescopically and revolubly mounted therein, a chair seat mounted upon the end of said piston, said chair seat being adjustable to different reclining positions, a crank-shaft journaled in said piston, an operating handle for said crank-shaft, pump mechanism operated from said crank-shaft for raising said piston and chair seat, said pumping mechanism having provision, controlled by the movement of said handle in a direction beyond one of the limits of its pumping stroke, for lowering said piston and chair seat, means for producing a dead stroke of said pump mechanism during a predetermined movement of said handle in the opposite direction beyond the limit of its pumping stroke, mechanism operated from crank-shaft for locking said piston against a revolving movement in said cylinder during the extreme outward movement of said handle in producing said dead stroke, and mechanism operated from said crank-shaft for releasing said chair-seat from a locked reclining position during the initial movement of said handle in producing said dead stroke; whereby the rotation of said crank-shaft to raise or lower the chair seat or to lock the same against revolving movement or to permit the adjusting of the reclining position of the chair seat is dependent upon a predetermined movement of the operating handle.

4. In a chair, the combination with a vertically mounted hollow cylinder, of a hollow-piston telescopically and revolubly mounted therein, a crank journaled in the upper end of said piston, pumping mechanism operated from said crank for raising or lowering said piston and chair seat, a pitman operated from said crank, means controlled by the movement of said pitman for locking or unlocking said piston in respect to its revolving movement in said cylinder, and means

for producing a dead stroke of said pumping mechanism upon the movement of said crank to lock said piston against revolving movement.

5 5. In a chair, the combination with a vertically mounted hollow cylinder, of a hollow piston telescopically and revolubly mounted therein, said piston being provided at its lower end with a solid piston head having a well therein, a chair seat mounted upon the upper end of said piston, a pump-piston fitting in said well, a crank for operating said pump-piston to force fluid from said hollow piston through said well into said cylinder and thereby to elevate said hollow piston and chair seat, a reciprocating wedge block mounted in said solid head, a plunger extending laterally from said solid head against the inner wall of said cylinder and adapted when pressed into frictional engagement therewith to lock said piston against revolving movement in said cylinder, the inner end of said plunger bearing against the wedge shaped edge of said wedge-block, a pitman connecting said wedge block to said crank arm, and means for providing a dead stroke of said pump-piston during the operation of said wedge block in pressing said plunger into frictional engagement with said cylinder.

6. In a chair, the combination with a hollow cylinder, of a hollow piston reciprocating therein, said piston being provided with a solid head having two longitudinally extending wells therein, valves controlling the bottom openings in said wells, a pump-piston reciprocating in each of said wells, and crank mechanism for operating said pump-piston to force fluid from said hollow-piston through said valves into said cylinder and thus to elevate the hollow-piston, a reciprocating block mounted in parallel relation to said pump-pistons, means controlled by the position of said block to lock said hollow piston against revolving movement in said cylinder, and a pitman connecting said block with said crank mechanism.

7. In a chair, the combination with a vertically mounted hollow cylinder, of a hollow piston telescopically mounted therein, said piston being provided with a solid head having three parallel longitudinal openings therethrough, outwardly opening valves at the bottom of two of said openings, double acting pump-pistons reciprocating in said latter openings for forcing fluid from said hollow piston into said cylinder, a wedge block reciprocating in said third opening, a crank journaled in said hollow piston, connecting members connecting said pump-pistons and said wedge block with said crank, means operated at the extreme downward movement of said wedge block for locking said hollow piston against revolving movement in said cylinder, means for providing

a dead stroke of the downward moving pump piston during such extreme downward movement of the wedge block, and means for positively holding open the valve controlled by the other pump-piston at the limit of the opposite extreme movement of the crank.

8. In a chair, the combination with a vertically mounted hollow cylinder, of a hollow piston telescopically and revolubly mounted therein, a chair seat mounted upon the upper end of said piston, a pump piston arranged within said hollow piston, a crank for operating said pump piston to force fluid from said hollow piston into said cylinder, and thereby to elevate said hollow piston and chair seat, a reciprocating wedge mounted in the lower end of said hollow piston, a plunger extending laterally from said hollow piston against the inner wall of said cylinder, and adapted when pressed into frictional engagement therewith to lock said piston against revolving movement in said cylinder, the inner end of said plunger bearing against the inclined surface of said wedge, a pitman connecting said wedge to said crank arm, and means for providing a dead stroke of said pump piston during the operation of said wedge in pressing said plunger into frictional engagement with said cylinder.

9. In a chair, the combination with a hollow cylinder, of a hollow piston reciprocating therein, said piston being provided with two parallel longitudinally extending wells, a pump piston reciprocating in each of said wells, crank mechanism for operating said pump pistons to force fluid from said hollow piston into said cylinder, and thus to elevate the hollow piston, a reciprocating wedge mounted in parallel relation to said pump piston, means controlled by the position of said wedge to lock said hollow piston against revolving movement of said cylinder, and a pitman connecting said wedge with said crank mechanism.

10. In a chair, the combination with a vertically mounted hollow cylinder, of a hollow piston telescopically mounted therein, said piston being provided with a solid head having three parallel longitudinal openings therethrough, double acting pump pistons reciprocating in two of said openings for forcing fluid from said hollow piston into said cylinder, a wedge reciprocating in said third opening, a crank journaled in said hollow piston, connecting members connecting said pump pistons and said wedge with said crank, and means operated by said wedge at the extreme downward movement thereof for locking said hollow piston against revolving movement against said cylinder.

11. In a chair, the combination with an upright, hollow cylinder, of a hollow piston

reciprocating therein a crank journaled in the upper end of said piston, a handle for operating said crank, said piston being provided at its lower end with a solid head having two longitudinally extending wells therein, the bores of said wells being enlarged at their lower ends, outwardly opening valves closing the bottoms of said wells, pump-pistons reciprocating in said wells, the sides of the pump-pistons near the bottoms thereof being provided with holes normally closed by the walls of said wells but open when said pump-pistons are in their lowermost positions, cooperating means provided on one only of said valves and the corresponding pump-piston for positively holding said valve in its open position at the extreme downward position of the corresponding pump-piston, whereby at one of the extreme positions of said operating handle the chair is lowered and at the other extreme position thereof a dead stroke is provided, and mechanism operated by the movement of the crank during such dead stroke of the handle for locking said hollow piston against rotation in said hollow cylinder.

12. In a chair, the combination with a ver-

tically mounted hollow cylinder, of a hollow piston telescopically and revolubly mounted therein, said piston being provided at its lower end with a solid piston head having a well therein, a pump-piston fitting in said well, crank mechanism for operating said pump-piston to force fluid from said hollow piston through said well into said cylinder, a reciprocating block mounted in said solid head, means controlled by the position of said block to lock said hollow piston against revolving movement in said cylinder, and a pitman pivoted at its upper end to said crank mechanism and connected at its lower end to said block by pin and slot connection to provide for loose play between said pitman and block and thereby to permit a slight elevation of the pitman after the block has been moved into locking position without a consequent movement of said block.

In witness whereof, I hereunto subscribe my name this 23d day of May A. D., 1908.

ANDREW L. UNDELAND.

Witnesses:

FRANK L. WEAVER,
J. Q. BURGNER.