

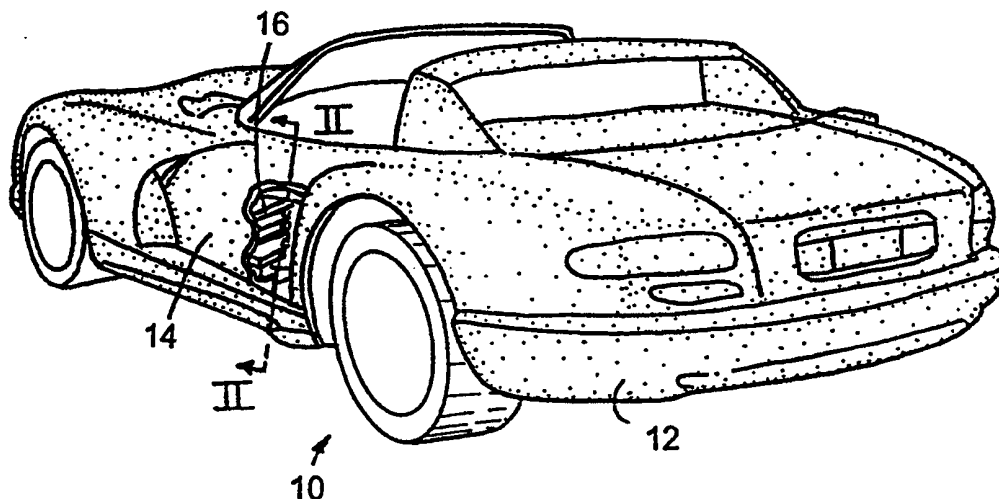

## INTERNATIONAL APPLICATION PUBLISHED UNDER THE PATENT COOPERATION TREATY (PCT)

<p>(51) International Patent Classification <sup>6</sup> : B29C 44/46, B32B 5/18, C08J 9/14</p>	A1	<p>(11) International Publication Number: <b>WO 99/00236</b></p> <p>(43) International Publication Date: 7 January 1999 (07.01.99)</p>
<p>(21) International Application Number: PCT/US98/13376</p> <p>(22) International Filing Date: 26 June 1998 (26.06.98)</p> <p>(30) Priority Data: 60/051,155 27 June 1997 (27.06.97) US 60/053,343 22 July 1997 (22.07.97) US</p> <p>(71) Applicant (for all designated States except US): THE DOW CHEMICAL COMPANY [US/US]; 2030 Dow Center, Midland, MI 48674 (US).</p> <p>(72) Inventors; and (75) Inventors/Applicants (for US only): TUSIM, Martin, H. [US/US]; 1408 Peppermill Circle, Midland, MI (US). CORNELL, Martin, C. [US/US]; 333 Timbercreek Drive, Lake Jackson, TX 77566 (US). SUH, Kyung, W. [US/US]; 6204 Evergreen Court, Midland, MI (US). CHRISTENSON, Christopher, P. [US/US]; 5255 South Hunter, Beaverton, MI (US). PARK, Chung, P. [US/DE]; Schulstrasse 10a, D-76532 Baden-Baden (DE).</p> <p>(74) Agent: ROBERTS, John, H.; Patent Dept., P.O. Box 1967, Midland, MI 48641-1967 (US).</p>	<p>(81) Designated States: AL, AM, AT, AU, AZ, BA, BB, BG, BR, BY, CA, CH, CN, CU, CZ, DE, DK, EE, ES, FI, GB, GE, GH, GM, GW, HU, ID, IL, IS, JP, KE, KG, KP, KR, KZ, LC, LK, LR, LS, LT, LU, LV, MD, MG, MK, MN, MW, MX, NO, NZ, PL, PT, RO, RU, SD, SE, SG, SI, SK, SL, TJ, TM, TR, TT, UA, UG, US, UZ, VN, YU, ZW, ARIPO patent (GH, GM, KE, LS, MW, SD, SZ, UG, ZW), Eurasian patent (AM, AZ, BY, KG, KZ, MD, RU, TJ, TM), European patent (AT, BE, CH, CY, DE, DK, ES, FI, FR, GB, GR, IE, IT, LU, MC, NL, PT, SE), OAPI patent (BF, BJ, CF, CG, CI, CM, GA, GN, ML, MR, NE, SN, TD, TG).</p> <p><b>Published</b> <i>With international search report. Before the expiration of the time limit for amending the claims and to be republished in the event of the receipt of amendments.</i></p>	

(54) Title: ENERGY ABSORBING ARTICLES OF EXTRUDED THERMOPLASTIC FOAMS



## (57) Abstract

An energy absorbing article having a direction in which impact resistance is desired is formed of extruded thermoplastic foam exhibit anisotropic compressive strength. The extrusion direction of the thermoplastic foam is aligned substantially parallel with the direction in which impact resistance is desired to provide an energy absorbing article exhibiting a high ratio of compressive strength to weight. In accordance with a particular aspect of this invention, the thermoplastic foams may be prepared by the extrusion foaming of a molten thermoplastic composition utilizing a die including a multiplicity of orifices. In addition to coextrudates comprising coalescend strand foams having foam strands of two or more different densities, the extruded thermoplastic foams exhibiting anisotropic strength properties which may be utilized in accordance with the principles of this invention include coextrudates including foam strands and a unitary (integral piece) interleaving profile of an unfoamed thermoplastic.

*FOR THE PURPOSES OF INFORMATION ONLY*

Codes used to identify States party to the PCT on the front pages of pamphlets publishing international applications under the PCT.

<b>AL</b>	Albania	<b>ES</b>	Spain	<b>LS</b>	Lesotho	<b>SI</b>	Slovenia
<b>AM</b>	Armenia	<b>FI</b>	Finland	<b>LT</b>	Lithuania	<b>SK</b>	Slovakia
<b>AT</b>	Austria	<b>FR</b>	France	<b>LU</b>	Luxembourg	<b>SN</b>	Senegal
<b>AU</b>	Australia	<b>GA</b>	Gabon	<b>LV</b>	Latvia	<b>SZ</b>	Swaziland
<b>AZ</b>	Azerbaijan	<b>GB</b>	United Kingdom	<b>MC</b>	Monaco	<b>TD</b>	Chad
<b>BA</b>	Bosnia and Herzegovina	<b>GE</b>	Georgia	<b>MD</b>	Republic of Moldova	<b>TG</b>	Togo
<b>BB</b>	Barbados	<b>GH</b>	Ghana	<b>MG</b>	Madagascar	<b>TJ</b>	Tajikistan
<b>BE</b>	Belgium	<b>GN</b>	Guinea	<b>MK</b>	The former Yugoslav Republic of Macedonia	<b>TM</b>	Turkmenistan
<b>BF</b>	Burkina Faso	<b>GR</b>	Greece	<b>ML</b>	Mali	<b>TR</b>	Turkey
<b>BG</b>	Bulgaria	<b>HU</b>	Hungary	<b>MN</b>	Mongolia	<b>TT</b>	Trinidad and Tobago
<b>BJ</b>	Benin	<b>IE</b>	Ireland	<b>MR</b>	Mauritania	<b>UA</b>	Ukraine
<b>BR</b>	Brazil	<b>IL</b>	Israel	<b>MW</b>	Malawi	<b>UG</b>	Uganda
<b>BY</b>	Belarus	<b>IS</b>	Iceland	<b>MX</b>	Mexico	<b>US</b>	United States of America
<b>CA</b>	Canada	<b>IT</b>	Italy	<b>NE</b>	Niger	<b>UZ</b>	Uzbekistan
<b>CF</b>	Central African Republic	<b>JP</b>	Japan	<b>NL</b>	Netherlands	<b>VN</b>	Viet Nam
<b>CG</b>	Congo	<b>KE</b>	Kenya	<b>NO</b>	Norway	<b>YU</b>	Yugoslavia
<b>CH</b>	Switzerland	<b>KG</b>	Kyrgyzstan	<b>NZ</b>	New Zealand	<b>ZW</b>	Zimbabwe
<b>CI</b>	Côte d'Ivoire	<b>KP</b>	Democratic People's Republic of Korea	<b>PL</b>	Poland		
<b>CM</b>	Cameroon	<b>KR</b>	Republic of Korea	<b>PT</b>	Portugal		
<b>CN</b>	China	<b>KZ</b>	Kazakstan	<b>RO</b>	Romania		
<b>CU</b>	Cuba	<b>LC</b>	Saint Lucia	<b>RU</b>	Russian Federation		
<b>CZ</b>	Czech Republic	<b>LI</b>	Liechtenstein	<b>SD</b>	Sudan		
<b>DE</b>	Germany	<b>LK</b>	Sri Lanka	<b>SE</b>	Sweden		
<b>DK</b>	Denmark	<b>LR</b>	Liberia	<b>SG</b>	Singapore		
<b>EE</b>	Estonia						

**ENERGY ABSORBING ARTICLES OF EXTRUDED THERMOPLASTIC FOAMS**

This invention relates to articles formed of thermoplastic foams, and in particular to energy or impact absorbing articles, such as automobile energy absorbing units, made of thermoplastic foams.

In recent years, light weight plastic automobile energy absorbing units (EAUs) have been employed in conjunction with conventional metal automobile bumpers to absorb low energy (lower speed) impacts. The plastic automobile EAUs are usually employed in front of the bumpers. Plastic automobile EAUs are usually composed of a core material of a plastic foam and a surface material of a synthetic resin enclosing the foam core and are usually mounted on a rigid cross beam. Plastic materials which have been proposed for the foam core material include polyurethane, polyethylene bead, polystyrene and polypropylene bead foams. The foam core material is an important component part which affects the performance of an automobile EAU, and is generally required to have excellent energy absorbing properties and dimensional recovery. Further, to decrease the weight of an automobile, the EAU core material should be of low density.

Polyurethane foam EAU cores have excellent energy absorbing properties and dimensional recovery, but have relatively high density. As a result, the polyurethane foam EAU cores are relatively heavy and expensive. Polystyrene foam has relatively poor dimensional recovery and impact strength. Accordingly, automobile EAU cores made of foamed beads of an olefinic polymer, especially a polypropylene-type resin, are most common.

A conventional automobile EAU core of foamed olefinic polymer is prepared by feeding expandable beads of a polypropylene-type resin in a mold capable of enclosing the particles but allowing escape of gases therefrom, and heating the expandable beads at a temperature at which the beads expand and soften and melt-adhere to each other into a mass, whereby a foamed molded article expanded to the same shape and size as the cavity of the mold is formed. An automobile EAU core prepared from beads of a polypropylene-type resin foam requires a foam density of about 12.5 pounds per cubic foot to achieve a compressive strength of about 250 pounds per square inch at 25% strain. Automobile EAU cores having comparable compressive strength at a lower density would be desirable.

According to the present invention, there is provided an energy absorbing article formed of an extruded thermoplastic foam which exhibits anisotropic strength properties, and a method of absorbing impact using an extruded thermoplastic foam which exhibits anisotropic strength properties. The extruded thermoplastic foam can be utilized in energy absorbing articles in which the high strength direction of the foam is generally aligned with the direction at which impact with the energy absorbing article is anticipated.

FIG. 1 is a perspective view of an automobile, with a portion of the side door outer panel broken away to reveal an extruded thermoplastic foam contained within the door;

FIG. 2 is a sectional view along lines II-II of FIG. 1;

FIG. 3 is a top plan view of the rear EAU of the automobile shown in FIG. 1, with portions broken away to reveal thermoplastic foam extrudates contained within the EAU;

FIG. 4 is a graph of compressive strength at 25% strain (psi) as a function of density (pounds per cubic foot), comparing the compressive strength of an extruded polyolefin foam in accordance with the invention to the compressive strength of a conventional molded article prepared by dispersing expandable beads of a polypropylene resin in a closed vessel and heating beads at a temperature at which the beads expand and soften and melt-adhere to each other into a mass;

FIG. 5 is a transverse cross section of a thermoplastic foam composite comprising alternating relatively thin, relatively high density non-foamed layers and relatively thick, relatively low density foamed layers;

FIG. 6 is a transverse cross section of a thermoplastic foam composite having a network of relatively thin, relatively high density intersecting film layers defining spaces occupied by relatively low density thermoplastic foam;

FIG. 7 is a transverse cross section of a thermoplastic foam composite including a foam core and a higher density skin which acts as a monocoque-like reinforcement structure; and

FIG. 8 is a transverse cross section of a thermoplastic foam article having a decorative layer attached thereto.

5 In FIG. 1 there is shown an automobile 10 having an impact absorbing rear EAU 12 and a side door 14 including an impact absorbing extruded thermoplastic foam insert 16 contained within a cavity of the door. As shown in more detail in FIG. 2, the thermoplastic foam insert 16 is located between an outer wall 18 and inner wall 20 of the side door 14. Thermoplastic foam insert 16 is an extruded thermoplastic foam exhibiting  
10 anisotropic strength characteristics. More specifically, foam insert 16 exhibits greater strength in one direction than in any other direction. Thermoplastic foam insert 16 is oriented within side door 14 so that the direction in which strength is greatest is approximately perpendicular to a vertical plane extending longitudinally to automobile 10, i.e., approximately perpendicular to the door wall panels 18, 20. The thermoplastic foam  
15 exhibiting anisotropic strength properties is therefore oriented so that the maximum strength direction is approximately aligned with the direction in which impact resistance is desired.

As shown in FIG. 3, rear EAU 12 includes an exposed face 22 which is approximately perpendicular to the direction in which high impact resistance is desired. EAU  
20 12 includes a covering 24 of conventional design and contains one or more extruded thermoplastic foam inserts 26, 27, 28, each of which exhibits anisotropic strength properties wherein the strength in one direction is greater than in any other direction. Thermoplastic foam inserts 26, 27, and 28 are oriented so that the direction in which strength is greatest is approximately aligned with the longitudinal direction of the automobile, i.e., approximately  
25 perpendicular with the exposed face 22 of rear EAU 12. Alignment may also be perpendicular to the outer edge of covering 24.

Suitable foamable thermoplastic compositions include polyethylene, including low density polyethylene and high density polyethylene (HDPE), polypropylene, and co-  
30 polymers of ethylene or propylene and a monoethylenically unsaturated monomer copolymerizable therewith. Examples include copolymers of ethylene and acrylic acid or methylacrylic acid and C<sub>1-4</sub> alkyl esters or ionomeric derivatives thereof; ethylene vinyl- acetate copolymers; ethylene/carbon monoxide copolymers; anhydride containing olefin copolymers of a diene; copolymers of ethylene and an alpha-olefin having ultra low  
35 molecular weight (i.e., densities less than 0.92 g/cc); blends of all of the above resins; blends

thereof with polyethylene (high, intermediate or low density); etc. Preferred polyolefins include polypropylene homopolymers and copolymers of polypropylene which are comprised of at least about 50% propylene by weight. Other suitable polyolefins include branched polypropylene homopolymer and branched copolymers of polypropylene.

5

The polymers of ethylene or propylene and a polar co-monomer may be prepared by known addition polymerization techniques, or by grafting reaction of the reactive co-monomer with a preformed polymer of ethylene or propylene. Additional elastomeric components such as polyisobutylene, polybutadiene, ethylene/propylene copolymers, and ethylene/propylene/diene interpolymers may be included in the blend if desired. Moreover, additional components such as cross linking agents designed to provide latent cross linking of the ethylenic or propylenic polymer, such as silane functional cross linking agents, or covalent or ionic cross linking agents, may be included if desired.

10

Other suitable foamable thermoplastic compositions which may be used in the practice of this invention include polyesters, polyamides, polyvinylchloride, polyvinylidene chloride, polycarbonates and polystyrene resins.

15

The thermoplastic polymer material or blend is melt processed in a conventional manner by feeding, melting, metering it into a conventional melt processing apparatus such as an extruder. A volatile blowing agent and an optional cross linking agent are mixed with the polyolefin polymer or blend under a pressure suitable to form a flowable gel or admixture. A cross linking agent may be added in an amount which is sufficient to initiate cross linking and raise the pressure of the gel or admixture to less than that pressure which causes melt fracture of the polymer to occur. The term "melt fracture" is used in the art to describe a melt flow instability of a polymer as it is extruded through a die, which flow instability causes voids and/or other irregularities in the final product.

20

25

It is also possible to add various additives such as inorganic fillers, pigments, anti-oxidants, acid scavengers, ultraviolet absorbers, flame retardants, surfactants, processing aids, extrusion aids and the like.

30

One additive which is not necessary, but is generally desirable in some circumstances is a nucleating agent as is generally known in the art. As a nucleating agent optionally used in this invention for controlling dispersion and size of cells, there can be

35

referred to inorganic substances such as calcium carbonate, talc, clay, titanium oxide, silica, barium sulfate, diatomaceous earth and the like, carbon dioxide generated by the combination of a bicarbonate or a carbonate of sodium, potassium, ammonium or the like and an inorganic or organic acid such as boric acid, citric acid, tartaric acid or the like, thermal decomposition type chemical foaming agents such as azodicarbonamide, benzenesulfonyl hydrazide, toluenesulfonyl hydrazide and the like, etc. Among them, finally pulverized products or inorganic substances such as calcium carbonate, talc and the like are relatively preferred in that they have no restriction as to extrusion temperature.

10 The amount of nucleating agent may be appropriately selected from the range of 0.01-5 parts by weight per 100 parts by weight of the thermoplastic resin or blend. In this range, the most preferable amount is 0.1-3 parts by weight. In generally, an increased amount of nucleating agent gives a smaller diameter of cell. However, if the amount exceeds 5 parts by weight, agglomeration or insufficient dispersion of nucleating substance occurs, so that the diameter of the cell becomes greater. On the contrary, if the amount is less than 0.01 parts by weight, the nucleating action is too feeble to decrease the diameter of the cells.

20 The volatile foaming agents usable in this invention generally have a boiling point temperature range of -90°C to +80°C, and include, but are not limited to, aliphatic hydrocarbons such as n-pentane, isopentane, neo-pentane, isobutane, n-butane, propane, ethane and the like; fluoro-chlorinated hydrocarbons such as dichlorotetrafluoroethane, trifluoroethane, trichloromonofluoromethane, dichlorodifluoromethane, dichloromonofluoromethane and the like. Among them, the non-fully halogenated hydrocarbons are preferred on account of environmental considerations. Particularly preferred among the non-fully halogenated hydrocarbons are partially or fully fluorinated hydrocarbons and non-fully halogenated fluoro-chlorinated hydrocarbons. Examples of these include 1-chloro-1,1-fluoroethane, 1,1,1,2-tetra fluoroethane and 1,1-difluoroethane.

30 Other blowing agents which may be employed include HFC 152a, HCFC 142b, and HFC 134a. Particularly preferred among the aliphatic hydrocarbons is isobutane and isobutane/n-butane mixtures. Other blowing agents which may be employed include alcohols such as methanol and ethanol. Also contemplated are inorganic blowing agents such as carbon dioxide, water, nitrogen, argon and combinations thereof, as well as combinations of these inorganic blowing agents with hydrocarbon and/or halogenated hydrocarbon blowing agents.

Also decomposable blowing agents, such as azobisformamide, may be incorporated with the volatile foaming agents. Mixtures of any or all of these volatile foaming agents are also contemplated within the scope of this invention. Also contemplated are combinations including water and/or carbon dioxide as the primary blowing agent.

5

From the view point of foaming workability and quality of foam product, the amount of foaming agent added to the thermoplastic resin or blend is preferably in the range of 0.012-0.14 gram mole by weight per 100 grams by weight of the thermoplastic resin or blend. Typically, the amount of foaming agent incorporated into the thermoplastic resin or  
10 blend depends on the desired foam density. In general, incorporation of a greater amount of foaming agent results in a higher expansion ratio (the term "expansion ratio" herein referred to means the ratio of the density of the resin or blend to the density of the expanded product) and thus a lower foam density. However, care must be taken not to incorporate an amount of foaming agent that causes a separation between resin and foaming agent in the extruder.  
15 When this happens, "foaming in the die" occurs, and the surface of the expanded product becomes rough, generally producing an unsatisfactory product.

Other suitable methods of preparing and extruding foamable thermoplastic blends to produce extruded profiles which may be useful in preparing energy absorbing  
20 articles in accordance with the principles of this invention are disclosed in U.S. Patent Nos. 5,348,795; 5,527,573 and 5,567,742, all of which are hereby incorporated herein by reference.

The thermoplastic foam blends are generally prepared by heating the  
25 thermoplastic resin or blend to form a plasticized or melt polymer material, incorporating therein a blowing agent to form a foamable gel, and extruding the gel through a die to form the foam product. Prior to mixing with the blowing agent, the thermoplastic resin or blend is heated to a temperature at or above its glass transition temperature or melting point. The blowing agent may be incorporated or mixed into the melt polymer material by any means  
30 known in the art, such as with an extruder, mixture, blender, or the like. The blowing agent is mixed with the melt polymer material at an elevated pressure sufficient to prevent substantial expansion of the melt polymer material and to generally disperse the blowing agent homogeneously therein. Optionally, a nucleating agent may be blended in the polymer melt or dry blended with the polymer material prior to plasticizing or melting. The  
35 foamable gel is typically cooled to a lower temperature to optimize physical characteristics of

the foam structure. The gel may be cooled in the extruder or other mixing device or in separate coolers. The gel is then extruded or conveyed through a die of desired shape to a zone of reduced or lower pressure to form the foam product. The zone of lower pressure is at a pressure lower than that in which the foamable gel is maintained prior to extrusion  
5 through the die. The lower pressure may be super-atmospheric or sub-atmospheric (vacuum), but is preferably at an atmospherical level.

The thermoplastic foam may be open or closed-celled, as desired. The percentage of open cells can be controlled, as is well known in the art, by appropriate  
10 selection of blowing agents, additives, polymers, and processing parameters, such as temperatures, pressures, and extrusion rates.

In accordance with a particular aspect of this invention, the thermoplastic foams may be prepared by the extrusion foaming of a molten thermoplastic composition  
15 utilizing a die including a multiplicity of orifices. The orifices are so arranged such that the contact between adjacent streams of the molten extrudate occurs during the foaming process and the contacting surfaces adhere to one another with sufficient adhesion to result in a unitary structure. Desirably, the individual strands of coalesced foam should remain adhered into a unitary structure to prevent strain delamination under stresses encountered in  
20 preparing, shaping, and forming the foam product. U.S. Patent No. 4,824,720, which describes the coalesced (or stranded) foam process, is hereby incorporated by reference. This patent describes a method for providing a closed cell foam structure comprising a plurality of coalesced extruded strands or profiles by extrusion forming of a molten thermoplastic composition utilizing a die including a multiplicity of orifices. The coalesced  
25 strand foam may be a coextrudate comprising strands of two or more different densities.

Coextrusion methods and methods of varying the densities of thermoplastic foams are well known in the art and will not be described in detail herein. In addition to coextrudates comprising coalesced strand foams having foam strands of two or more different densities,  
30 the extruded thermoplastic foams exhibiting anisotropic strength properties which may be utilized in accordance with the principles of this invention include coextrudates including foam strands and a unitary (integral piece) interleaving profile of an unfoamed thermoplastic.

In accordance with a particular aspect of this invention, energy absorbing  
35 articles exhibiting anisotropic strength properties are prepared by extruding a foamable

thermoplastic gel through a die including a plurality of orifices arranged such that contact between adjacent streams of molten extrudate causes the surfaces thereof to adhere to form a unitary coalesced foam article, wherein the polymeric component of the foamable gel comprises a polymer blend including a major amount (greater than 50% by weight) of a homopolymer or copolymer in which the majority of monomeric units are propylene monomeric units and a minor amount (less than 50% by weight) of a polyethylene type resin modifier in which the majority of monomeric units are ethylene monomeric units. It has been discovered that the resulting coalesced strand foams produced from such polymeric blends unexpectedly exhibit increased tensile strength, especially in directions normal to the longitudinal direction of the coalesced strands (i.e., the extrusion direction), relative to coalesced strand foams made from polypropylene homopolymer or from a blend of polypropylene homopolymer and an ethylene-propylene copolymer resin modifier. The increased tensile strength, especially in directions normal to the longitudinal direction of the coalesced strands, is attributable to improved strand-to-strand adhesion caused by the addition of a minor amount of a polyethylene type resin modifier which is a homopolymer or copolymer comprised entirely or mostly of ethylene monomeric units. The polyethylene type resin modifiers will typically have a melting point lower than that of the polypropylene homopolymer or copolymer, and preferably have a melting point below about 125°C. The polyethylene type resin modifiers are comprised primarily of ethylene monomeric units, and more preferably are comprised of at least 80% ethylene monomeric units by weight.

Examples of preferred polyethylene type resin modifiers include low density polyethylene homopolymers and substantially linear ethylenic polymers having a melt flow ratio,  $I_1/I_2$ , greater than or equal to about 5.63, a molecular weight distribution,  $M_w/M_n$ , defined by the equation  $M_w/M_n \leq (I_1/I_2) - 4.63$ , and a critical shear rate at onset of surface melt fracture of at least 50% greater than the critical shear rate at the onset of surface melt fracture of a linear olefin polymer having about the same  $I_2$  and  $M_w/M_n$ . Substantially linear ethylenic polymers as set forth above are described in U.S. Patent Nos. 5,340,840 and 5,272,236, which are hereby incorporated by reference. Other preferred polyethylene type resin modifiers are homogeneously branched substantially linear ethylene/ $\alpha$ -olefin interpolymers having a density from about 0.89 g/cc to about 0.92 g/cc, a molecular weight distribution ( $M_w/M_n$ ) from about 1.8 to about 2.8, a melt index ( $I_2$ ) from about 0.001 grams/10 minutes to about 10 grams/10 minutes, no high density fraction, a single melting peak as measured using differential scanning calorimetry, a critical shear stress at onset of gross melt fracture greater than  $4 \times 10^6$  dynes/cm<sup>2</sup>, and a slope of strain hardening coefficient from 1.3 to 2.3

(description of Enhanced PE). These homogeneously branched substantially linear ethylene/a-olefin interpolymers are described in U.S. Patent No. 5,677,383 which is incorporated by reference herein. Other suitable ethylene type resin modifiers which may be used in a minor amount in combination with a propylene polymer in a major amount and  
5 extruded through a die having a multiplicity of orifices to form coalesced strand foams exhibiting enhanced strand-to-strand adhesion and improved tensile strength and modulus, especially in directions normal to the longitudinal direction of the coalesced strands, include medium density polyethylene (MDPE), high density polyethylenes (HDPE) (for example, those made using Ziegler catalysts as in U.S. Patent No. 4,076,698), ethylene/ester  
10 copolymers, ethylene/vinyl acetate copolymers, copolymers of ethylene and ethylenically unsaturated carboxylic acids, homopolymers and copolymers of alpha-ethylenics, etc.

Examples of commercially available polyethylene type resins which can be blended in a minor amount with a major amount of a polypropylene homopolymer or copolymer and  
15 extruded through a die having a multiplicity of orifices to form coalesced strand foams exhibiting improved strand-to-strand adhesion and improved tensile strength in a direction normal to the longitudinal direction of the coalesced strands include substantially linear ethylenic polymers sold by Dow Chemical Company under the mark "Affinity" and low density polyethylene sold by Dow under the mark "Elite". The polyethylene type resin  
20 modifiers when blended in a minor amount with a major amount of a propylene homopolymer or copolymer, combined with a blowing agent and other additives to form a foamable gel, and extruded through a die having a multiplicity of orifices, provide coalesced strand foams exhibiting significant improvement in tensile strength in a direction normal to the longitudinal direction of the coalesced strands as compared with a coalesced strand foam comprised of a  
25 polymeric blend including polypropylene homopolymer and an ethylene/propylene copolymer resin modifier which is comprised of about 20% ethylene monomeric units.

The coalesced strand foam energy absorbing articles of this invention may include missing strands or designed voids, i.e., a profile or cross section transverse to the  
30 extrusion direction which is discontinuous. Coalesced strand foam articles having missing strands or designed voids can be prepared by extruding a thermoplastic foamable gel through a die having a multiplicity of orifices arranged in an array defining voids such that the extruded strands are joined at their extremities to form a network defining voids. A die having a multiplicity of orifices which is designed to produce coalesced strand foams which  
35 do not have missing strands or designed voids can be modified to produce coalesced strand

foams having missing strands or designed voids by blocking off some of the orifices. Energy absorbing articles having designed voids may be advantageously employed in certain applications to allow manipulation of bulk density and softness (modulus control), and increase air flow. Also, the designed voids may be used for creating raceways for wires, optical fibers, and the like. Methods of forming stranded foam articles having designed voids are described in U.S. Patent No. 4,801,484 which is incorporated by reference herein.

The extruded thermoplastic foams exhibiting anisotropic strength property may also be prepared as extruded planks. Extruded thermoplastic foam planks may be pulled through a slit die at generally any rate of speed commonly used, and can be stretched or pulled from the die by any means known in the art, such as by pulling with opposing belts, nip rollers and like take-up means.

Although a particularly preferred method of preparing the energy absorbing articles exhibiting anisotropic strength properties involves extruding a foamable thermoplastic gel through a die including a multiplicity of orifices arranged such that contact between adjacent streams of molten extrudate causes the surfaces thereof to adhere and form a unitary coalesced foam article, other methods may be employed to form thermoplastic foam articles exhibiting similar or equivalent anisotropic strength properties.

An alternative method of forming foam articles exhibiting anisotropic strength properties is to extrude a thermoplastic foamable gel through a die having a desired profile (e.g., a rectangular profile), providing the extruded profile with a plurality of spaced apart (e.g., parallel) cuts, and subsequently thermally fusing the cut surfaces to reintegrate the extruded profile into a thermoplastic foam article 40 (FIG. 5) having a plurality of relatively thin, spaced apart thermoplastic non-foamed layers 42 having a higher density than the relatively thicker, lower density foam layers 44 interposed between the non-foamed layers. A suitable technique for cutting and fusing the cut surfaces of an extruded profile to form a thermoplastic article having a layered or laminated structure comprising alternating relatively thick foam layers and relatively thin non-foamed layers is to pass a thermoplastic foam profile through a tool having a plurality of spaced apart hot wires which cut through the profile and allow the freshly cut surfaces to readhere or fuse together, preferably immediately down stream of the hot wires. As the hot wires pass through the extruded profile, the thermoplastic foam softens or melts, collapsing the cellular foam structure in the immediate vicinity of the hot wire, and subsequently resolidifies to form a relatively thin,

relatively high density non-foamed layer. The resulting layered or laminated structure exhibits anisotropic strength properties. In particular, the resulting layered structure exhibits greater strength in a direction aligned with the planes in which the non-foamed layers are arranged than in a direction perpendicular to the planes in which the non-foamed layers are arranged.

A honeycomb-like composite structure 50 (FIG. 6) can be prepared by providing an extruded profile with a first set of spaced apart (e.g., parallel) cuts, and a second set of spaced apart (e.g., parallel) cuts which are arranged at an angle (e.g., perpendicular) with respect to the first set of cuts, and subsequently thermally fusing the cut surfaces together. This can be achieved by passing the extruded profile through a tool having spaced apart hot wires arranged in an array, such as with a first set of spaced apart hot wires arranged parallel to each other and a second set of spaced apart hot wires arranged parallel to each other and at an angle (such as perpendicular) to the first set of hot wires. As the hot wires pass through the extruded profile, the thermoplastic foam softens or melts, collapsing the cellular foam structure in the immediate vicinity of the hot wires, and subsequently resolidifies to form a network or array of relatively thin, relatively high density intersecting non-foamed layers 52 which form a honeycomb-like structure with the spaces defined by the boundaries of the intersecting walls being occupied by a relatively low density thermoplastic foam 54. The resulting honeycomb-like composite structure exhibits anisotropic strength properties. In particular, the honeycomb-like composite structure exhibits greater strength in a directional aligned with the planes of the intersecting non-foamed layers than in a direction perpendicular to the intersecting non-foamed layers. The first set of spaced apart hot wires and the second set of spaced apart hot wires can be arranged in a single tool, or in two different tools through which the extruded profile is advanced. Alternatively, a single tool having only one set of spaced apart hot wires can be used for forming the honeycomb-like composite structure, such as by advancing an extruded profile through the tool to form a first set of spaced apart films, rotating the resulting layered structure having alternating relatively thick foam layers and relatively thin non-foamed layers (such as 90°), and passing the layered structure through the same tool a second time, at a different angle with respect to the hot wires, to form a honeycomb-like composite structure.

As another alternative, the method of forming energy absorbing articles exhibiting anisotropic strength properties by providing the extruded profile with a plurality of spaced apart cuts and subsequently thermally fusing the cut surfaces together to reintegrate

the extruded profile into a thermoplastic foam article having a layered or honeycomb-like composite structure can be achieved by cutting the extruded profile with saws or blades, applying heat to the cut surfaces to soften or melt thermoplastic foam in the immediate vicinity of the cut surfaces to collapse the cellular foam structure, and immediately thereafter contacting the cut surfaces with each other to thermally fuse the surfaces together and form an integrated layered or honeycomb-like composite structure. The layered and honeycomb-like composite structures exhibiting anisotropic strength properties need not necessarily be prepared by reintegrating cut surfaces of an extruded foam profile, but may instead be prepared by thermally fusing surfaces (either cut surfaces or extrudate surfaces) of a plurality of thermoplastic foam pieces to form an integrated, unitary composite structure. As yet another alternative, thermoplastic foam pieces can be bonded together at their surfaces by applying a molten thermoplastic film, sheet or layer to surfaces of thermoplastic foam profiles and immediately thereafter joining the surfaces to form an integrated, unitary structure having alternating spaced apart thin non-foamed layers and relatively thick foam layers, or intersecting non-foamed layers which form a honeycomb-like structure. As yet another alternative, an adhesive, such as a thermosetting adhesive, may be utilized in place of the molten thermoplastic to join surfaces of an array of thermoplastic foam profiles to form the layered or honeycomb-like composite structures exhibit anisotropic strength properties. The molten thermoplastic materials and/or adhesives used for adhering surfaces of thermoplastic foam profiles to form an integrated, unitary energy absorbing article exhibiting anisotropic strength properties should exhibit good adhesive properties with the thermoplastic foam and should solidify to form films having strength properties superior to that of the thermoplastic foam.

Another method for making energy absorbing articles exhibiting enhancing or augmented anisotropic strength properties involves melting outer surfaces of a thermoplastic foam profile, or any of the previously described embodiments, and thermoforming the outer melted surfaces to provide a composite 60 (FIG. 7) including a relatively higher density skin 62 which acts as a monocoque-like reinforcement structure for the foam core 64. For example, the lateral surfaces of a foam profile having isotropic strength properties, or any of the previously described embodiments of the invention, may be melted and thermoformed to form a continuous skin 62 circumscribing the foam profile or energy absorbing article. The resulting structure has enhanced strength characteristics in a direction aligned with the circumscribing tubular skin. A similar monocoque-like structural reinforcement can be provided by laminating a separate structural skin to the outer surfaces of a thermoplastic

foam profile, or any of the previously described embodiments of the invention. The separate structural skin may be comprised of a polymer which is either the same or different from the polymer of which the thermoplastic foam is comprised.

5           The anisotropic strength properties of any of the previously described embodiments of the invention may be further enhanced or augmented by incorporation of continuous and/or discontinuous reinforcing fibers which may be oriented length wise in a direction in which high impact resistance is desired. Suitable reinforcing fibers include synthetic fibers, such as aramid, polyester, and polyolefin fibers; natural fibers, such as sisal;  
10 ceramic fibers; glass fibers; metallic fibers; and the like.

          The physical properties and thermal resistance of the foam may be enhanced by adding particles or fibers of organic or inorganic materials in the form of fillers. Such particulates or fibers could be added to foam-forming compositions during manufacturing.  
15 Useful materials include carbon black particulates, clay particulates, carbon or graphite fibers, polypropylene fibers, polyester fibers, and nylon fibers, glass fibers, liquid crystal fibers and the like. The physical properties and thermal resistance of the foam may also be enhanced by laminating to the foam non-foamed film/sheet layers or coatings containing such particles or fibers. Fibers may be of any length, short (fibrils) or long. They may be  
20 randomly dispersed or woven or placed together in the nature of a woven or non-woven fabric or prepreg.

          Adhesives known in the art may be employed to adhere various layers, such as decorative and/or functional fabrics, to any of the energy absorbing articles described  
25 herein. Useful adhesives include thermoset adhesives such as polyurethane resins and epoxies and thermoplastic adhesives such as polyethylenes, polypropylenes, ethylene copolymers; propylene copolymers; and the like. Useful adhesives are taught in U.S. Patent Nos. 5,460,870 and 5,670,211. The adhesive may be applied by any means known in the art such as by spraying, coating, or in film form. Preferred adhesives are thermoplastic  
30 because of their lower cost and potential recyclability. The presence of an adhesive is not critical to the present invention.

          A layer or layers of decorative material 70 (FIG. 8), such as felt or fabric, may be applied to the energy absorbing articles 72 of this invention for aesthetic purposes. The  
35 layer may be of any type known in the art. Examples include felts, or woven fabrics. Useful

fabrics include those of woven polyester, nylon and polypropylene fibers. Preferably, the felt or fabric layer is comprised of the same or similar polymeric material as the foam. The felt or fabric layer may be adhered to the foam by any means known in the art such as thermal welding, adhesive films, or adhesive liquids or coatings. For example, a decorative layer  
5 comprised of a woven fabric of thermoplastic fibers may be thermally welded to the energy absorbing articles of this invention without the benefit of adhesives. Thermal welding refers to heating of the fabric layer to an extent such that the fibers become tacky or sticky and are able to adhere to the energy absorbing article without the benefit of an adhesive. Alternatively, the energy absorbing article may be heated until the surface becomes tacky or  
10 sticky and is able to adhere to the fabric layer, or other intermediate layer. A fabric layer may be thermally welded to the surface of an energy absorbing article if applied during thermoforming.

We have discovered that the extruded thermoplastic foam products of this  
15 invention exhibit anisotropic strength properties. More specifically, we have determined that the strength in the extrusion direction is greater than the strength in directions perpendicular to the extrusion direction. Strength properties as used herein include, but are not necessarily limited to, compressive strength, compressive modulus, and impact resistance. For example, depending upon the various parameters, materials and apparatus used during  
20 the extrusion, compressive strength in the extrusion direction may be 25%, 50%, 100%, or even 200% or more greater than in a direction perpendicular to the extrusion direction. For example, stranded or coalesced polypropylene extrudates have exhibited compressive strength in the extruded direction which is more than four times that in a direction perpendicular to the extrusion direction. Accordingly, the energy absorbing articles of this  
25 invention are formed of extruded thermoplastic foam exhibiting the above noted anisotropic compressive strength properties, with the direction of maximum strength of the extruded thermoplastic foam being approximately aligned with the direction in which impact is expected and impact resistance is desired. In particular, the direction of maximum strength of the thermoplastic foam extrudate and the direction in which impact resistance is desired in  
30 the energy absorbing article should differ by an angle of less than about 45°, more preferably less than 10°, and most preferably less than 5°. Approximate alignment of the direction of maximum strength of the thermoplastic foam with the direction in which impact is expected or occurs or in which impact resistance is desired means that the direction of maximum strength of the extrudate is more nearly parallel to the direction in which impact resistance is  
35 desired than perpendicular to the direction in which impact resistance is desired. A 180°

rotation of the extrudate about an axis perpendicular to the direction of maximum strength and with respect to a first orientation is generally equivalent to that first orientation.

Desirably, the materials, i.e., the thermoplastic resin or blend, nucleating  
5 agents, foaming agents, and process parameters, e.g., temperatures and extrusion rate, are selected so that the foamed extrudate has a density of less than 20 pounds per cubic foot, preferably from about 2 to 12 pounds per cubic foot, more preferably 2.5 to 10 pounds per cubic foot, and most preferably from about 3 to 8 pounds per cubic foot. The resulting  
10 extrudates exhibit anisotropic compressive strength properties, with the highest compressive strengths generally being observed in the extrusion direction. The extrudates typically have a compressive strength in the extrusion direction of at least about 25 psi (pounds per square inch) at about 25% strain, more preferably at least about 45 psi at 25% strain, and most preferably at least about 75 psi at 25% strain as measured in accordance with ASTM D3575-93 (Suffix D).

15

The extruded thermoplastic foam products in accordance with this invention can be foamed or formed into the desired shape of the energy absorbing article, such as an automobile EAU, in which it is used, or the extruded thermoplastic foam may be cut and shaped into the desired shape of the energy absorbing article. Alternatively, the energy  
20 absorbing article may be comprised of a plurality of components which are joined, such as by hot air welding, steam welding, radio frequency welding, adhesives, mechanical fasteners, or the like, to form a composite energy absorbing article. In this manner, energy absorbing articles having unusual shapes, or containing portions of various density may be prepared. Also, composite articles containing materials other than the extruded  
25 thermoplastic foam may be prepared. Another alternative method of utilizing the extruded thermoplastic foams of this invention in composite energy absorbing articles is to use the extruded thermoplastic foams as inserts in a closed mold in which a suitable matrix resin is dispersed.

30

The polymeric foam energy absorbing articles of this invention which exhibit anisotropic strength properties have broad applicability in transportation, shipping containers, building and construction, as well as automotive application. Automotive applications include energy absorbing structures for front and rear end systems, doors, seats, and instrument panel components. Load bearing applications include floor pans, belly pans, seat  
35 components, hard top convertible roofs, lift gates, and pickup tailgates and boxes.

The methods disclosed herein can be used for forming various articles having general utility in various cushioning application such as casings, packaging and the like. In addition to forming EAUs, the methods of this invention can be employed to prepare various other energy absorbing automotive components such as headliners, pillar trim  
5 reinforcements, instrument panel reinforcements, seat cushions and seating systems, and tailgates.

#### EXAMPLE 1

10 A polypropylene homopolymer was extruded through a die having a multiplicity of orifices to produce a coalesced or stranded polypropylene foam extrudate. By appropriately varying process parameters, coalesced strand polypropylene extrudates at varying densities were prepared. For purposes of comparison, commercially available  
15 polypropylene particles were fed into a mold capable of enclosing the particles but allowing escape of gases therefrom, and heated to form foamed molded articles at various densities. The foamed extrudates exhibited anisotropic compressive strength properties, whereas the molded polypropylene foamed articles exhibited isotropic compressive strength properties. In FIG. 4, the compressive strength of the foamed extrudate in the extrusion direction at 25%  
20 strain is plotted as a function of density, and compared with the compressive strength at 25% strain of the molded foamed article as a function of density. FIG. 4 clearly demonstrates that the extruded polyolefin foam products of this invention (curve A) exhibit substantially higher compressive strengths than the conventional molded polyolefin foam products (curve B).

#### EXAMPLE 2

This example involves the preparation and testing of various coalesced strand foams in which the polymeric component is comprised of a blend including a major amount  
30 of a propylene homopolymer and a minor amount of a polyethylene type resin modifier in accordance with the principles of an aspect of this invention. The tests demonstrate that the polyethylene type resin modifiers provide significant improvements in tensile strength in a direction normal to the longitudinal direction of the coalesced strands.

For purposes of comparison, a coalesced strand foam was prepared using a polymeric blend comprising 88 parts by weight of a propylene homopolymer and 12 parts by weight of an ethylene/propylene (E/P) copolymer. Using an extruder, 12 parts of an ethylene/propylene copolymer (KS351P), 88 parts of a propylene homopolymer (6823), 0.1 parts each of Irganox 1010 and Ultrinox 626 (heat stabilizers), 0.4 parts talc, and 0.2 parts calcium stearate were blended. The blend exited the extruder at 185°C-200°C prior to being mixed with 16 parts of isobutane blowing agent either in a mixing extruder section or other equipment to mix liquid blowing agent with molten polymer. The mixture was then cooled to 160°C prior to being extruded through the die. At the die, the mixture was extruded through a multiplicity of orifices to produce a coalesced strand foam. After allowing the foam to cure at room temperature for one week, tensile tests sample were cut from the foam pieces to allow the foam strand-to-strand adhesion to be measured. The horizontal tensile tests was done in accordance with standard ASTM testing methods.

Six working examples in accordance with the principles of this invention were also prepared and tested in a substantially identical manner, except that the E/P copolymer was replaced with 12 parts of each of six different polyethylene type resin modifiers in accordance with the principles of this invention. The results are set forth below in Table I.

Resin Used		Resin Properties	Tensile Strength (psi)	Tensile Modulus (psi)
KS351P	E/P Copolymer	0.4 MI	6.5	137
DPF-1340	Enhanced PE	3.0 MI .909 g/cc	8.8	82
DPF-1340	Enhanced PE	3.0 MI .909 g/cc	11.4	144
LDPE 620I	LDPE	1.8 MI .920 g/cc	8.1	116
PL1280	AFFINITY PE	6.0 MI .900 g/cc	9.3	138
PL1880	AFFINITY PE	1.0 MI .902 g/cc	10.4	167.5
EG8150	AFFINITY PE	0.5 MI .868 g/cc	11.0	142

All of the coalesced strand foams containing the polyethylene type resin modifiers of the invention exhibited improved strand-to-strand adhesion (as exemplified by

the significant improvement in tensile strength as measured in a direction normal to the longitudinal direction of the coalesced strands) as compared with a coalesced strand foam prepared from a polymeric blend of propylene homopolymer and ethylene/propylene copolymer.

The embodiments of the invention in which an exclusive property or privilege is claimed are defined as follows:

-1-

5 A method of absorbing impact, comprising:  
providing a thermoplastic foam having greater strength in a first direction than in any other direction; and  
impacting the thermoplastic foam in a direction which is approximately aligned with the first direction in which compressive strength is greatest.

10

-2-

The method of claim 1, wherein the extruded thermoplastic foam is a coalesced strand foam.

-3-

15 The method of claim 1, wherein the extruded thermoplastic foam is a coextruded coalesced strand foam with strands of two or more different densities.

-4-

The method of claim 1, wherein the thermoplastic foam is a coextrudate including foam strands and a unitary interleaving profile of an unfoamed thermoplastic.

-5-

20 The method of claim 1, wherein the thermoplastic foam comprises a polyolefin.

-6-

25 The method of claim 5, wherein the polyolefin consists primarily of a polypropylene homopolymer, or a copolymer of propylene which propylene repeat units comprise at least 50% of the copolymer by weight.

-7-

30 The method of claim 1, wherein the thermoplastic foam is comprised of a polymeric blend including a major amount of a homopolymer or copolymer in which the majority of monomeric units are propylene monomeric units and a minor amount of a polyethylene type resin modifier in which a majority of monomeric units are ethylene monomeric units.

-8-

The method of claim 7, wherein the polyethylene type resin modifier has a melting point below about 125°C.

-9-

The method of claim 8, wherein the polyethylene type resin modifier are comprised of at least 80% ethylene monomeric units by weight.

-10-

5 The method of claim 9, wherein the polyethylene type resin modifier is a low density polyethylene homopolymer.

-11-

10 The method of claim 9, wherein the polyethylene type resin modifier is a substantially linear ethylenic polymer having a melt flow ratio ( $I_{10}/I_2$ ) greater than or equal to about 5.63, a molecular weight distribution defined by the equation  $M_w/M_n \leq (I_{10}/I_2) - 4.63$ , and a critical shear rate at onset of surface melt fracture of at least 50% greater than the critical shear rate at the onset of surface melt fracture of a linear olefin polymer having about the same  $I_2$  and  $M_w/M_n$ .

-12-

15 The method of claim 9, wherein the polyethylene type resin modifier is a homogeneously branched substantially linear ethylene/a-olefin interpolymer having a density from about 0.89 g/cc to about 0.92 g/cc, a molecular weight distribution ( $M_w/M_n$ ) from about 1.8 to about 2.8, a melt index ( $I_2$ ) from about 0.001 grams per 10 minutes to about 10 grams per 10 minutes, no high density fraction, a single melting peak as measured using differential scanning calorimetry, a critical shear stress at onset of gross melt factor greater than  $4 \times 10^6$  dynes/cm<sup>2</sup>, and a slope of strain hardening coefficient from 1.3 to 2.3.

-13-

20 The method of claim 2, wherein the extruded thermoplastic foam includes designed voids.

25

-14-

The method of claim 1, wherein the extruded thermoplastic foam has a layered structure comprising alternating relatively thick foam layers and relatively thin non-foamed layers.

-15-

30

The method of claim 1, wherein the extruded thermoplastic foam includes a network of relatively thin, relatively high density intersecting non-foamed layers which form a honeycomb-like structure, with spaces defined by the intersecting walls being occupied by relatively low density thermoplastic foam.

-16-

The method of claim 1, wherein the thermoplastic foam has thermoformed outer surfaces which act as a monocoque-like reinforcement structure.

-17-

5 The method of claim 1, wherein the thermoplastic foam includes reinforcing fibers.

-18-

The method of claim 17, wherein the reinforcing fibers are oriented lengthwise in a direction in which high impact resistance is desired.

-19-

10 The method of claim 1, wherein the thermoplastic foam further comprises particulate materials in the form of fillers.

-20-

The method of claim 1, wherein the thermoplastic foam further comprises a layer of decorative material.

15

-21-

The method of claim 1, wherein the compressive strength of the thermoplastic foam in the extrusion direction is at least 25% greater than in any direction perpendicular to the extrusion direction.

-22-

20

The method of claim 1, wherein the compressive strength of the thermoplastic foam in the extrusion direction is at least 50% greater than in a direction perpendicular to the extrusion direction.

-23-

25 The method of claim 1, wherein the compressive strength of the thermoplastic foam in the extrusion direction is at least 100% greater than in a direction perpendicular to the extrusion direction.

-24-

The method of claim 1, wherein the density of the extruded thermoplastic foam is at least 2 pounds per cubic foot.

30

-25-

The method of claim 1, wherein the density of the extruded thermoplastic foam is at least 2.5 pounds per cubic foot.

-26-

35 The method of claim 1, wherein the density of the extruded thermoplastic foam is at least about 3 pounds per cubic foot.

-27-

The method of claim 1, wherein the density of the extruded thermoplastic foam is less than 20 pounds per cubic foot.

-28-

5 The method of claim 1, wherein the extruded thermoplastic foam is oriented so that the direction in which the strength is greatest for the thermoplastic foam differs from the direction in which the thermoplastic foam is impacted by an angle of less than about 45°.

-29-

10 The method of claim 1, wherein the extruded thermoplastic foam is oriented so that the direction in which the strength is greatest for the thermoplastic foam differs from the direction in which the thermoplastic foam is impacted by an angle of less than about 10°.

-30-

15 The method of claim 1, wherein the extruded thermoplastic foam is oriented so that the direction in which the strength is greatest for the thermoplastic foam differs from the direction in which the thermoplastic foam is impacted by an angle of less than about 5°.

-31-

The method of claim 1, wherein the compressive strength of the thermoplastic foam in the direction in which strength is greatest is at least about 25 pounds per square inch at 25% strain.

20

-32-

The method of claim 1, wherein the compressive strength of the thermoplastic foam in the direction in which strength is greatest is at least about 45 pounds per square inch at 25% strain.

-33-

25 The method of claim 1, wherein the compressive strength of the thermoplastic foam in the direction in which strength is greatest is at least about 75 pounds per square inch at 25% strain.

-34-

A method of absorbing impact, comprising:

30 obtaining an extruded thermoplastic foam having greater strength in a first direction than in any other direction; and

incorporating the extruded thermoplastic foam into an energy absorbing article having a surface intended to absorb impact, the extruded thermoplastic foam being arranged in the article so that the first direction in which strength is greatest is approximately  
35 perpendicular to the surface intended to absorb impact.

-35-

The method of claim 34, wherein the extruded thermoplastic foam is a coalesced strand foam.

-36-

5 The method of claim 34, wherein the extruded thermoplastic foam is a coextruded coalesced strand foam with strands of two or more different densities.

-37-

10 The method of claim 34, wherein the thermoplastic foam is a coextrudate including foam strands and a unitary interleaving profile of an unfoamed thermoplastic.

-38-

The method of claim 34, wherein the thermoplastic foam comprises a polyolefin.

-39-

15 The method of claim 38, wherein the polyolefin consists primarily of a polypropylene homopolymer, or a copolymer of propylene which propylene repeat units comprise at least 50% of the copolymer by weight.

-40-

20 The method of claim 34, wherein the thermoplastic foam is comprised of a polymeric blend including a major amount of a homopolymer or copolymer in which the majority of monomeric units are propylene monomeric units and a minor amount of a polyethylene type resin modifier in which a majority of monomeric units are ethylene monomeric units.

-41-

25 The method of claim 40, wherein the polyethylene type resin modifier has a melting point below about 125°C.

-42-

The method of claim 41, wherein the polyethylene type resin modifier are comprised of at least 80% ethylene monomeric units by weight.

-43-

30 The method of claim 42, wherein the polyethylene type resin modifier is a low density polyethylene homopolymer.

-44-

35 The method of claim 42, wherein the polyethylene type resin modifier is a substantially linear ethylenic polymer having a melt flow ratio ( $I_{10}/I_2$ ) greater than or equal to about 5.63, a molecular weight distribution defined by the equation  $M_w/M_n \leq (I_{10}/I_2) - 4.63$ , and

a critical shear rate at onset of surface melt fracture of at least 50% greater than the critical shear rate at the onset of surface melt fracture of a linear olefin polymer having about the same  $I_2$  and  $M_w/M_n$ .

-45-

5           The method of claim 42, wherein the polyethylene type resin modifier is a homogeneously branched substantially linear ethylene/ $\alpha$ -olefin interpolymer having a density from about 0.89 g/cc to about 0.92 g/cc, a molecular weight distribution ( $M_w/M_n$ ) from about 1.8 to about 2.8, a melt index ( $I_2$ ) from about 0.001 grams per 10 minutes to about 10 grams per 10 minutes, no high density fraction, a single melting peak as measured using differential  
10 scanning calorimetry, a critical shear stress at onset of gross melt factor greater than  $4 \times 10^6$  dynes/cm<sup>2</sup>, and a slope of strain hardening coefficient from 1.3 to 2.3.

-46-

The method of claim 35, wherein the extruded thermoplastic foam includes designed voids.

15

-47-

The method of claim 34, wherein the extruded thermoplastic foam has a layered structure comprising alternating relatively thick foam layers and relatively thin non-foamed layers.

-48-

20

The method of claim 34, wherein the extruded thermoplastic foam includes a network of relatively thin, relatively high density intersecting non-foamed layers which form a honeycomb-like structure, with spaces defined by the intersecting walls being occupied by relatively low density thermoplastic foam.

-49-

25

The method of claim 34, wherein the thermoplastic foam has thermoformed outer surfaces which act as a monocoque-like reinforcement structure.

-50-

The method of claim 34, wherein the thermoplastic foam includes reinforcing fibers.

30

-51-

The method of claim 50, wherein the reinforcing fibers are oriented lengthwise in a direction in which high impact resistance is desired.

-52-

35           The method of claim 34, wherein the thermoplastic foam further comprises particulate materials in the form of fillers.

-53-

The method of claim 34, wherein the thermoplastic foam further comprises a layer of decorative material.

-54-

5 The method of claim 34, wherein the compressive strength of the thermoplastic foam in the extrusion direction is at least 25% greater than in any direction perpendicular to the extrusion direction.

-55-

10 The method of claim 34, wherein the compressive strength of the thermoplastic foam in the extrusion direction is at least 50% greater than in a direction perpendicular to the extrusion direction.

-56-

15 The method of claim 34, wherein the compressive strength of the thermoplastic foam in the extrusion direction is at least 100% greater than in a direction perpendicular to the extrusion direction.

-57-

The method of claim 34, wherein the density of the extruded thermoplastic foam is at least 2 pounds per cubic foot.

-58-

20 The method of claim 34, wherein the density of the extruded thermoplastic foam is at least 2.5 pounds per cubic foot.

-59-

The method of claim 34, wherein the density of the extruded thermoplastic foam is at least about 3 pounds per cubic foot.

25

-60-

The method of claim 34, wherein the density of the extruded thermoplastic foam is less than 20 pounds per cubic foot.

-61-

30 The method of claim 34, wherein the extruded thermoplastic foam is oriented so that the direction in which the strength is greatest for the thermoplastic foam differs from the direction in which the thermoplastic foam is impacted by an angle of less than about 45°.

-62-

35 The method of claim 34, wherein the extruded thermoplastic foam is oriented so that the direction in which the strength is greatest for the thermoplastic foam differs from the direction in which the thermoplastic foam is impacted by an angle of less than about 10°.

-63-

The method of claim 34, wherein the extruded thermoplastic foam is oriented so that the direction in which the strength is greatest for the thermoplastic foam differs from the direction in which the thermoplastic foam is impacted by an angle of less than about 5°.

5

-64-

The method of claim 34, wherein the compressive strength of the thermoplastic foam in the direction in which strength is greatest is at least about 25 pounds per square inch at 25% strain.

-65-

10

The method of claim 34, wherein the compressive strength of the thermoplastic foam in the direction in which strength is greatest is at least about 45 pounds per square inch at 25% strain.

-66-

15

The method of claim 34, wherein the compressive strength of the thermoplastic foam in the direction in which strength is greatest is at least about 75 pounds per square inch at 25% strain.

-67-

An energy absorbing article, comprising:

a surface in which impact resistance is desired;

20

an extruded thermoplastic foam incorporated into the energy absorbing article, the extruded thermoplastic foam having greater strength in a first direction than in any other direction; and

the extruded thermoplastic foam being oriented so that the first direction in which strength is greatest is approximately aligned with the direction in which impact resistance is desired.

25

-68-

The article of claim 67, wherein the extruded thermoplastic foam is a coalesced strand foam.

-69-

30

The article of claim 67, wherein the extruded thermoplastic foam is a coextruded coalesced strand foam with strands of two or more different densities.

-70-

The article of claim 67, wherein the thermoplastic foam is a coextrudate including foam strands and a unitary interleaving profile of an unfoamed thermoplastic.

-71-

The article of claim 67, wherein the thermoplastic foam comprises a polyolefin.

-72-

5 The article of claim 71, wherein the polyolefin consists primarily of a polypropylene homopolymer, or a copolymer of propylene which propylene repeat units comprise at least 50% of the copolymer by weight.

-73-

10 The article of claim 67, wherein the thermoplastic foam is comprised of a polymeric blend including a major amount of a homopolymer or copolymer in which the majority of monomeric units are propylene monomeric units and a minor amount of a polyethylene type resin modifier in which a majority of monomeric units are ethylene monomeric units.

-74-

15 The article of claim 73, wherein the polyethylene type resin modifier has a melting point below about 125°C.

-75-

The article of claim 74, wherein the polyethylene type resin modifier are comprised of at least 80% ethylene monomeric units by weight.

20

-76-

The article of claim 75, wherein the polyethylene type resin modifier is a low density polyethylene homopolymer.

-77-

25 The article of claim 75, wherein the polyethylene type resin modifier is a substantially linear ethylenic polymer having a melt flow ratio ( $I_1/I_2$ ) greater than or equal to about 5.63, a molecular weight distribution defined by the equation  $M_w/M_n \leq (I_1/I_2) - 4.63$ , and a critical shear rate at onset of surface melt fracture of at least 50% greater than the critical shear rate at the onset of surface melt fracture of a linear olefin polymer having about the same  $I_2$  and  $M_w/M_n$ .

30

-78-

The article of claim 75, wherein the polyethylene type resin modifier is a homogeneously branched substantially linear ethylene/a-olefin interpolymer having a density from about 0.89 g/cc to about 0.92 g/cc, a molecular weight distribution ( $M_w/M_n$ ) from about 1.8 to about 2.8, a melt index ( $I_2$ ) from about 0.001 grams per 10 minutes to about 10 grams per 10 minutes, no high density fraction, a single melting peak as measured using differential

35

scanning calorimetry, a critical shear stress at onset of gross melt factor greater than  $4 \times 10^6$  dynes/cm<sup>2</sup>, and a slope of strain hardening coefficient from 1.3 to 2.3.

-79-

5 The article of claim 68, wherein the extruded thermoplastic foam includes designed voids.

-80-

The article of claim 67, wherein the extruded thermoplastic foam has a layered structure comprising alternating relatively thick foam layers and relatively thin non-foamed layers.

10

-81-

The article of claim 67, wherein the extruded thermoplastic foam includes a network of relatively thin, relatively high density intersecting non-foamed layers which form a honeycomb-like structure, with spaces defined by the intersecting walls being occupied by relatively low density thermoplastic foam.

15

-82-

The article of claim 67, wherein the thermoplastic foam has thermoformed outer surfaces which act as a monocoque-like reinforcement structure.

-83-

20 The article of claim 67, wherein the thermoplastic foam includes reinforcing fibers.

-84-

The article of claim 83, wherein the reinforcing fibers are oriented lengthwise in a direction in which high impact resistance is desired.

-85-

25 The article of claim 67, wherein the thermoplastic foam further comprises particulate materials in the form of fillers.

-86-

The article of claim 67, wherein the thermoplastic foam further comprises a layer of decorative material.

30

-87-

The article of claim 67, wherein the compressive strength of the thermoplastic foam in the extrusion direction is at least 25% greater than in any direction perpendicular to the extrusion direction.

-88-

The article of claim 67, wherein the compressive strength of the thermoplastic foam in the extrusion direction is at least 50% greater than in a direction perpendicular to the extrusion direction.

-89-

5 The article of claim 67, wherein the compressive strength of the thermoplastic foam in the extrusion direction is at least 100% greater than in a direction perpendicular to the extrusion direction.

-90-

10 The article of claim 67, wherein the density of the extruded thermoplastic foam is at least 2 pounds per cubic foot.

-91-

The article of claim 67, wherein the density of the extruded thermoplastic foam is at least 2.5 pounds per cubic foot.

-92-

15 The article of claim 67, wherein the density of the extruded thermoplastic foam is at least about 3 pounds per cubic foot.

-93-

The article of claim 67, wherein the density of the extruded thermoplastic foam is less than 20 pounds per cubic foot.

20

-94-

The article of claim 67, wherein the extruded thermoplastic foam is oriented so that the direction in which the strength is greatest for the thermoplastic foam differs from the direction in which the thermoplastic foam is impacted by an angle of less than about 45°.

-95-

25 The article of claim 67, wherein the extruded thermoplastic foam is oriented so that the direction in which the strength is greatest for the thermoplastic foam differs from the direction in which the thermoplastic foam is impacted by an angle of less than about 10°.

-96-

30 The article of claim 67, wherein the extruded thermoplastic foam is oriented so that the direction in which the strength is greatest for the thermoplastic foam differs from the direction in which the thermoplastic foam is impacted by an angle of less than about 5°.

-97-

35 The article of claim 67, wherein the compressive strength of the thermoplastic foam in the direction in which strength is greatest is at least about 25 pounds per square inch at 25% strain.

-98-

The article of claim 67, wherein the compressive strength of the thermoplastic foam in the direction in which strength is greatest is at least about 45 pounds per square inch at 25% strain.

5

-99-

The article of claim 67, wherein the compressive strength of the thermoplastic foam in the direction in which strength is greatest is at least about 75 pounds per square inch at 25% strain.

10

-100-

An automobile including an impact absorbing member exhibiting high impact resistance in a desired direction, said impact absorbing member comprising an extruded thermoplastic foam having greater strength in a first direction than in any other direction, the extruded thermoplastic foam being oriented so that the first direction in which strength is greatest is approximately aligned with the direction in which impact resistance is desired.

15

-101-

The automobile of claim 100, wherein said extruded thermoplastic foam is incorporated into an automobile EAU attached to said automobile, and the direction in which strength is greatest for the extruded thermoplastic foam is approximately aligned with the longitudinal direction of the automobile.

20

-102-

The automobile of claim 100 in which the extruded thermoplastic foam is located in a side door of the automobile, and the direction in which strength is greatest for the extruded thermoplastic foam is approximately perpendicular to a vertical plane extending longitudinally to the automobile.

25

-103-

The automobile of claim 100 in which the thermoplastic foam is located in the roof structure of the automobile, and the direction in which strength is greatest for the extruded thermoplastic foam is approximately perpendicular to the horizontal plane of the roof of the automobile.

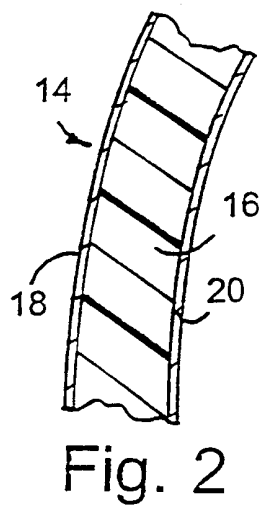
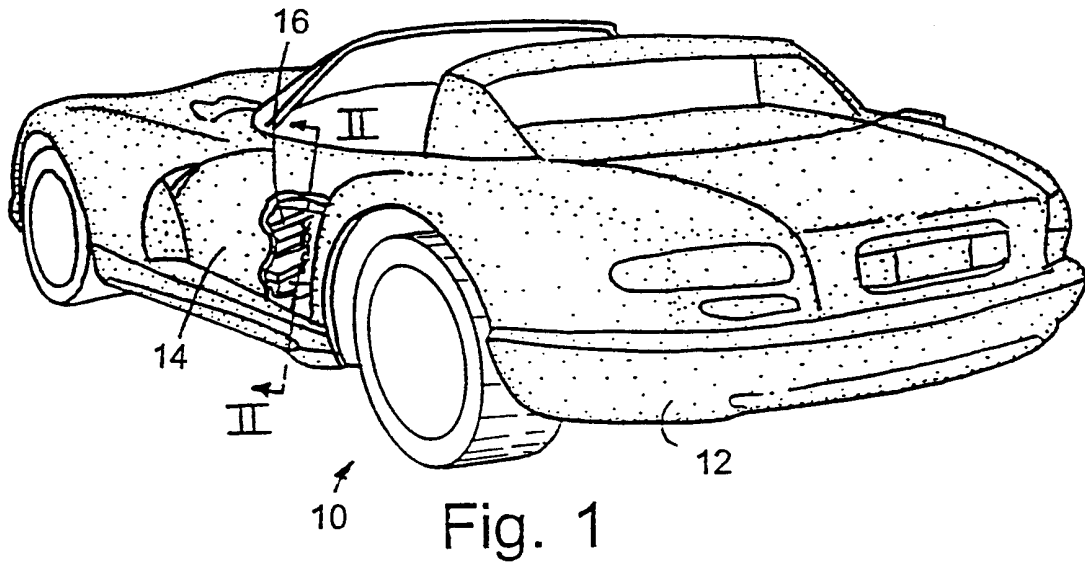

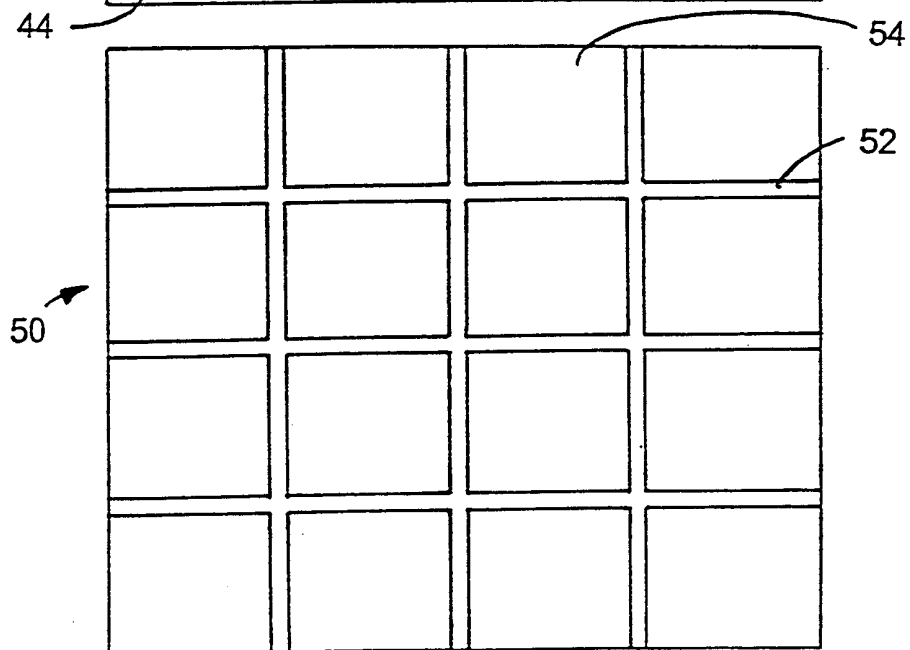
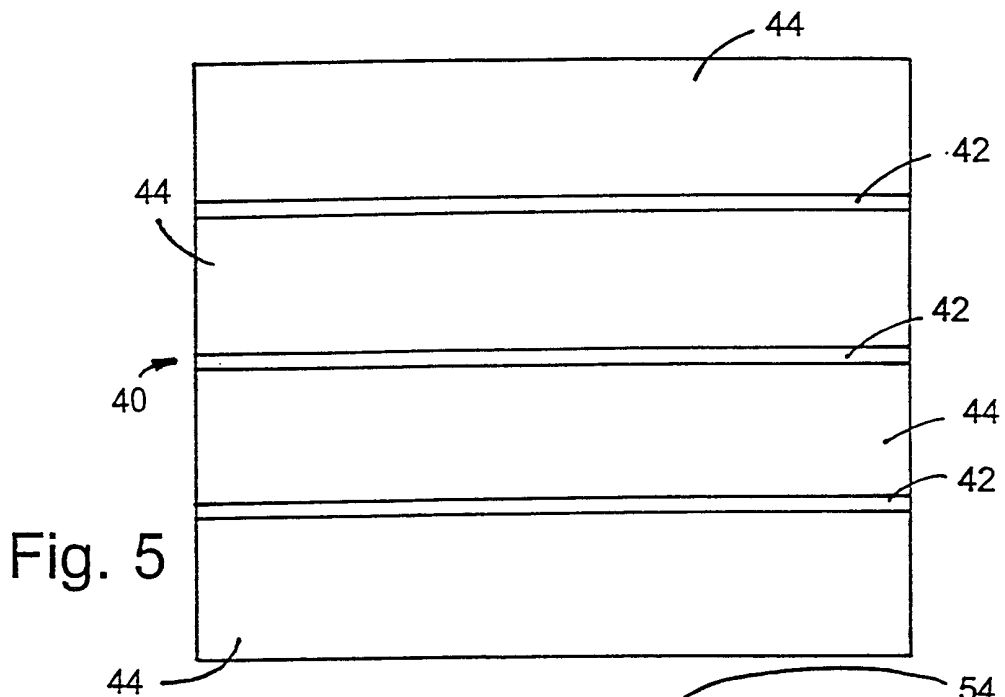
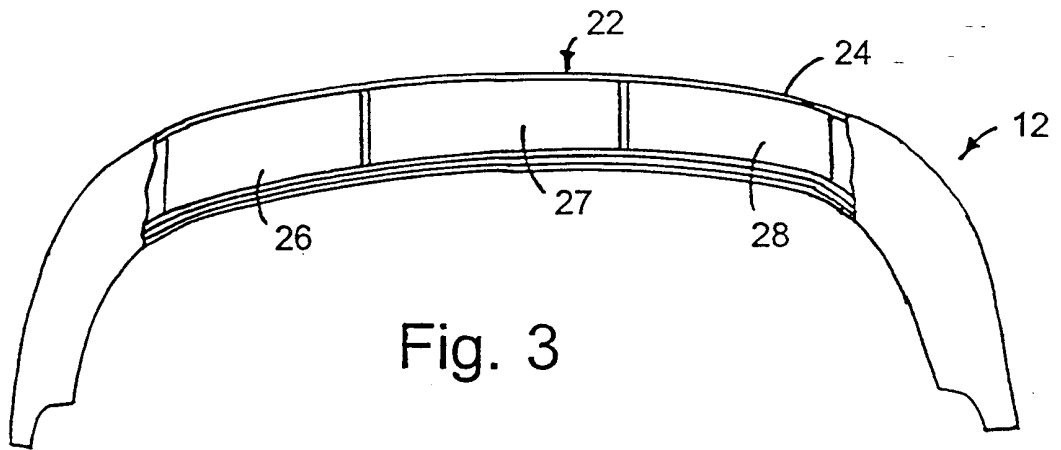

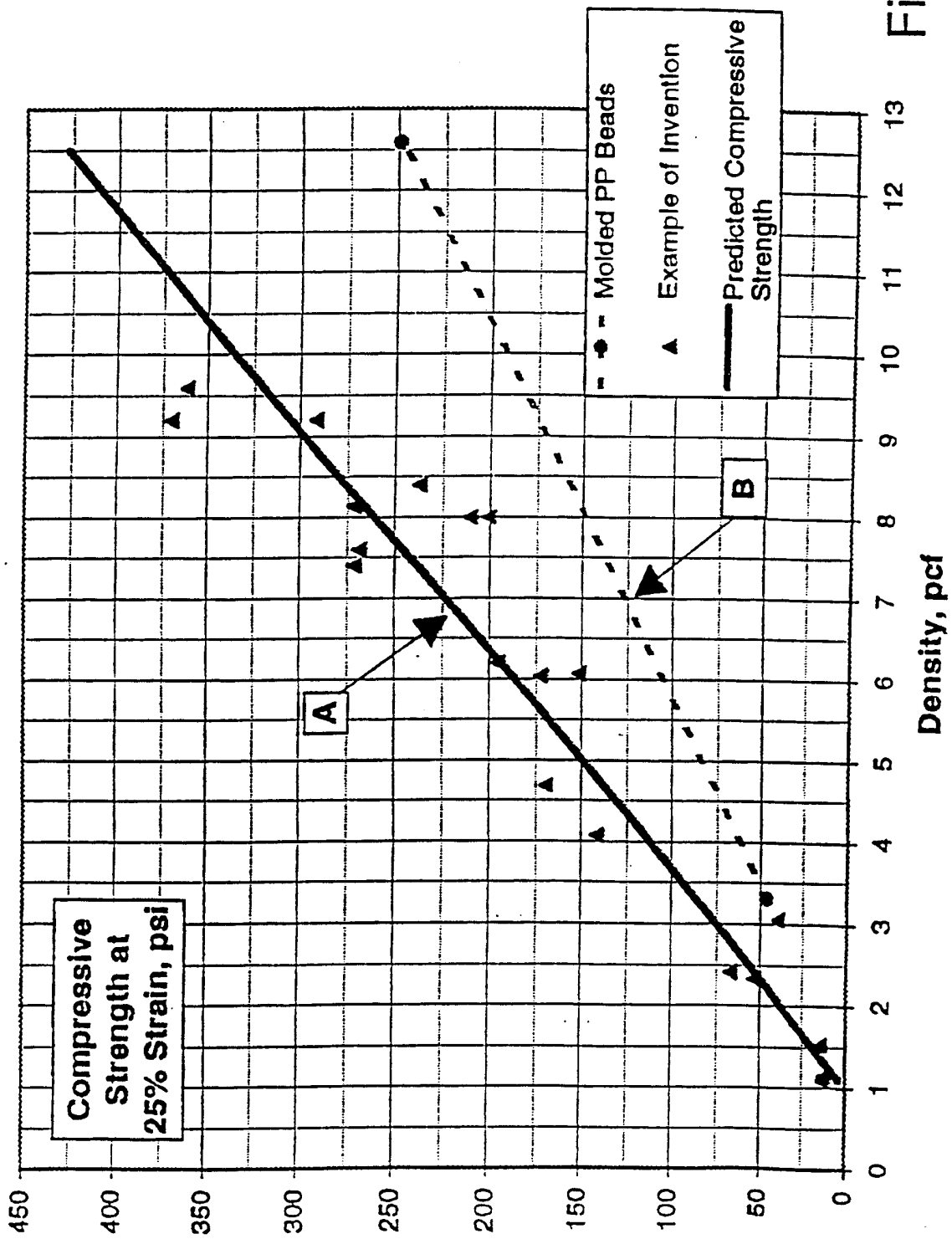

Fig. 4

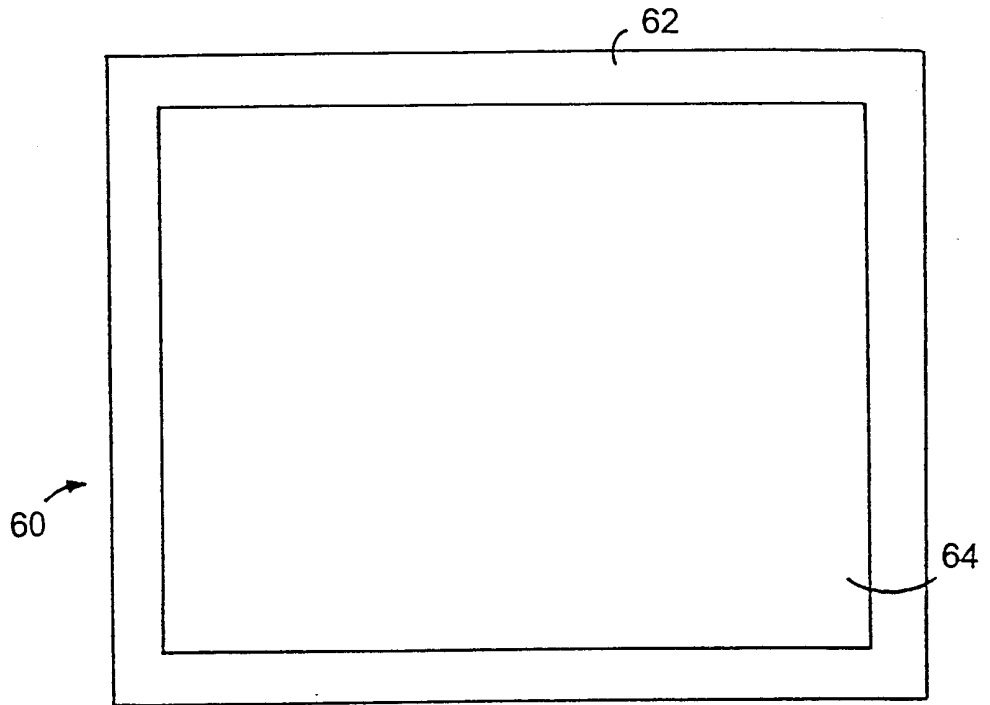

Fig. 7

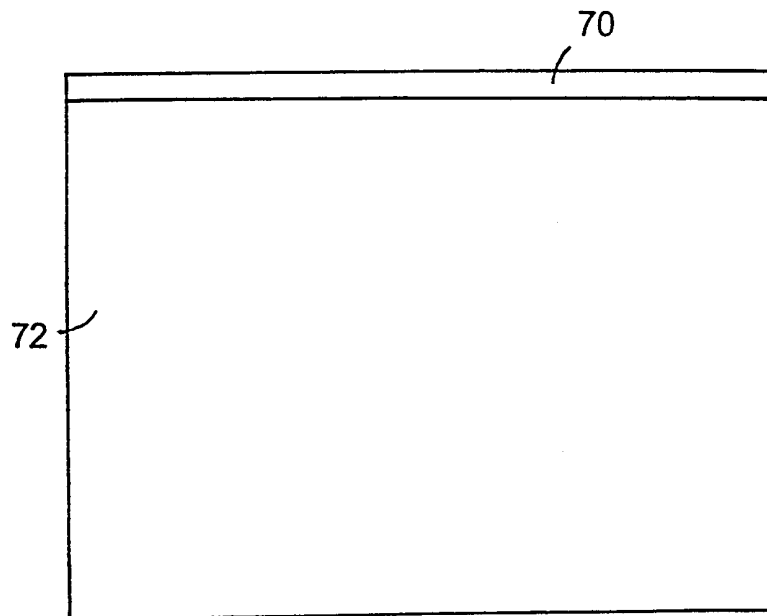

Fig. 8

# INTERNATIONAL SEARCH REPORT

International Application No

PCT/US 98/13376

**A. CLASSIFICATION OF SUBJECT MATTER**

IPC 6 B29C44/46 B32B5/18 C08J9/14

According to International Patent Classification(IPC) or to both national classification and IPC

**B. FIELDS SEARCHED**

Minimum documentation searched (classification system followed by classification symbols)

IPC 6 B29C

Documentation searched other than minimum documentation to the extent that such documents are included in the fields searched

Electronic data base consulted during the international search (name of data base and, where practical, search terms used)

**C. DOCUMENTS CONSIDERED TO BE RELEVANT**

Category	Citation of document, with indication, where appropriate, of the relevant passages	Relevant to claim No.
X	US 3 884 455 A (WELLER PETER A ET AL) 20 May 1975 see column 3, line 67 - column 4, line 2; claims 1,4,5; figures	1,16,49, 82
Y		2,5-7, 13, 18-20, 24-30, 34,35, 38-40, 46, 51-53, 57-63, 67,68, 71-73, 79,84-86
Y	---	90-96, 100,101

Further documents are listed in the continuation of box C.

Patent family members are listed in annex.

Special categories of cited documents :

- "A" document defining the general state of the art which is not considered to be of particular relevance
- "E" earlier document but published on or after the international filing date
- "L" document which may throw doubts on priority claim(s) or which is cited to establish the publication date of another citation or other special reason (as specified)
- "O" document referring to an oral disclosure, use, exhibition or other means
- "P" document published prior to the international filing date but later than the priority date claimed

- "T" later document published after the international filing date or priority date and not in conflict with the application but cited to understand the principle or theory underlying the invention
- "X" document of particular relevance; the claimed invention cannot be considered novel or cannot be considered to involve an inventive step when the document is taken alone
- "Y" document of particular relevance; the claimed invention cannot be considered to involve an inventive step when the document is combined with one or more other such documents, such combination being obvious to a person skilled in the art.
- "&" document member of the same patent family

Date of the actual completion of the international search  <p style="text-align: center; font-weight: bold;">6 November 1998</p>	Date of mailing of the international search report  <p style="text-align: center; font-weight: bold;">18/11/1998</p>
Name and mailing address of the ISA European Patent Office, P.B. 5818 Patentlaan 2 NL - 2280 HV Rijswijk Tel. (+31-70) 340-2040, Tx. 31 651 epo nl, Fax: (+31-70) 340-3016	Authorized officer  <p style="text-align: center; font-weight: bold;">Pemberton, P</p>

INTERNATIONAL SEARCH REPORT

International Application No

PCT/US 98/13376

C.(Continuation) DOCUMENTS CONSIDERED TO BE RELEVANT

Category	Citation of document, with indication, where appropriate, of the relevant passages	Relevant to claim No.
Y	US 4 548 775 A (HAYASHI MOTOSHIGE ET AL) 22 October 1985  see abstract ---	2, 20, 28-30, 34, 35, 53, 61-63, 67, 68, 86, 94-96, 100, 101
Y	US 4 824 720 A (MALONE BRUCE A) 25 April 1989 cited in the application  see column 2, line 13 - line 19 see column 4, line 14 - line 17 see column 5, paragraph 3 - paragraph 4 ---	5, 6, 13, 24-27, 38, 39, 46, 57-60, 71, 72, 79, 90-93
Y	US 3 573 152 A (BELL FREDERICK D DE ET AL) 30 March 1971 see column 3, line 13 - line 23 see column 8, line 57 - line 70 ---	2, 35, 68
Y	US 4 801 484 A (YAO PETER C ET AL) 31 January 1989 cited in the application see claim 1 ---	7, 40, 73
A	US 3 887 322 A (JOHNSON KEITH G ET AL) 3 June 1975  see column 9, paragraph 2 ---	6, 39, 72  18, 19, 51, 52, 84, 85
A	US 5 460 870 A (ARTHURS TREVOR C) 24 October 1995 cited in the application ---	4, 14, 15, 37, 47, 48, 70, 80, 81
A	US 5 340 840 A (PARK CHUNG P ET AL) 23 August 1994 cited in the application see abstract ---	11, 12, 44, 45, 77, 78
A	US 4 136 226 A (GILMAN RICHARD L) 23 January 1979 see abstract ---	14, 47, 80
A	US 5 435 619 A (AKIMARU FUSAYOSHI ET AL) 25 July 1995 see abstract; figures ---	102
	-/--	

# INTERNATIONAL SEARCH REPORT

International Application No  
PCT/US 98/13376

C.(Continuation) DOCUMENTS CONSIDERED TO BE RELEVANT		
Category	Citation of document, with indication, where appropriate, of the relevant passages	Relevant to claim No.
A	US 5 180 628 A (HAARDT UDO ET AL) 19 January 1993  see the whole document ----	14, 47, 80, 100-103
A	DE 44 32 082 A (BAYER AG) 14 March 1996 ----	
P, A	DE 196 15 875 A (YMOS AG IND PRODUKTE) 23 October 1997 ----	
A	GB 1 547 764 A (MARLEY TILE CO LTD) 27 June 1979 ----	
A	US 3 852 150 A (WELLER P) 3 December 1974 -----	

# INTERNATIONAL SEARCH REPORT

Information on patent family members

International Application No

PCT/US 98/13376

Patent document cited in search report	Publication date	Patent family member(s)	Publication date		
US 3884455 A	20-05-1975	AR 201916 A	30-04-1975		
		CA 988541 A	04-05-1976		
		DE 2319073 A	25-10-1973		
		FR 2209681 A	05-07-1974		
		GB 1424436 A	11-02-1976		
		JP 49015876 A	12-02-1974		
		AU 5474673 A	24-10-1974		
		-----			
US 4548775 A	22-10-1985	NONE			
-----					
US 4824720 A	25-04-1989	AT 150690 T	15-04-1997		
		AU 618728 B	09-01-1992		
		AU 1368688 A	14-09-1988		
		DE 3855841 D	30-04-1997		
		DE 3855841 T	11-09-1997		
		DK 578388 A	17-10-1988		
		EP 0279668 A	24-08-1988		
		ES 2099062 T	16-05-1997		
		FI 884785 A	17-10-1988		
		GR 3023546 T	29-08-1997		
		JP 1502252 T	10-08-1989		
		JP 2620968 B	18-06-1997		
		KR 9600725 B	12-01-1996		
		WO 8806094 A	25-08-1988		
		-----			
		US 3573152 A	30-03-1971	NONE	
-----					
US 4801484 A	31-01-1989	AT 150690 T	15-04-1997		
		AU 618728 B	09-01-1992		
		AU 1368688 A	14-09-1988		
		DE 3855841 D	30-04-1997		
		DE 3855841 T	11-09-1997		
		EP 0279668 A	24-08-1988		
		ES 2099062 T	16-05-1997		
		GR 3023546 T	29-08-1997		
		JP 1502252 T	10-08-1989		
		JP 2620968 B	18-06-1997		
		KR 9600725 B	12-01-1996		
		WO 8806094 A	25-08-1988		
		-----			

# INTERNATIONAL SEARCH REPORT

Information on patent family members

International Application No

PCT/US 98/13376

Patent document cited in search report	A	Publication date	Patent family member(s)	Publication date
US 3887322	A	03-06-1975	NONE	
US 5460870	A	24-10-1995	GB 2277052 A CA 2120983 A EP 0620109 A	19-10-1994 15-10-1994 19-10-1994
US 5340840	A	23-08-1994	CA 2153902 A EP 0689562 A FI 954365 A JP 8508764 T WO 9421717 A US 5369136 A	29-09-1994 03-01-1996 03-10-1995 17-09-1996 29-09-1994 29-11-1994
US 4136226	A	23-01-1979	NONE	
US 5435619	A	25-07-1995	JP 5330341 A JP 5305880 A CA 2076717 A DE 69211254 D DE 69211254 T EP 0530042 A KR 9703595 B US 5306068 A	14-12-1993 19-11-1993 01-03-1993 11-07-1996 31-10-1996 03-03-1993 20-03-1997 26-04-1994
US 5180628	A	19-01-1993	DE 4101806 A AT 164345 T AU 645388 B AU 1038792 A CA 2059257 A DE 59108958 D EP 0496111 A ES 2113871 T JP 5138784 A MX 9200249 A NO 177341 B	30-07-1992 15-04-1998 13-01-1994 06-08-1992 24-07-1992 30-04-1998 29-07-1992 16-05-1998 08-06-1993 01-10-1992 22-05-1995
DE 4432082	A	14-03-1996	NONE	
DE 19615875	A	23-10-1997	NONE	

# INTERNATIONAL SEARCH REPORT

information on patent family members

International Application No

PCT/US 98/13376

Patent document cited in search report	Publication date	Patent family member(s)	Publication date
GB 1547764 A	27-06-1979	NONE	
US 3852150 A	03-12-1974	NONE	