



INTERNATIONAL APPLICATION PUBLISHED UNDER THE PATENT COOPERATION TREATY (PCT)

(51) International Patent Classification ⁵ : G21B 1/00	A1	(11) International Publication Number: WO 90/14669 (43) International Publication Date: 29 November 1990 (29.11.90)
(21) International Application Number: PCT/SE90/00320 (22) International Filing Date: 14 May 1990 (14.05.90) (30) Priority data: 8901798-2 19 May 1989 (19.05.89) SE (71) Applicant (for all designated States except US): AB TEKNISK UTVECKLING EHR [SE/SE]; Sköttorpsv. 1, S-772 00 Grängsberg (SE). (72) Inventor; and (75) Inventor/Applicant (for US only) : HAEFFNER, Erik [SE/SE]; Eskadervägen 8, S-183 54 Täby (SE). (74) Agents: ROSENQUIST, P., O. et al.; P O Rosenquist Patentbyrå AB, P O Box 260, S-151 23 Södertälje (SE).		(81) Designated States: AT (European patent), BE (European patent), CH (European patent), DE (European patent)*, DK (European patent), ES (European patent), FR (European patent), GB (European patent), IT (European patent), JP, LU (European patent), NL (European patent), SE (European patent), US. Published <i>With international search report.</i> <i>In English translation (filed in Swedish).</i>

(54) Title: PRODUCTION OF FUSION ENERGY**(57) Abstract**

By a high voltage electrical discharge, as an arc or sparks, between metal electrodes (2, 3) immersed in heavy water, D₂O, free deuterons, heavy hydrogen nuclei, with high kinetic energy, are generated and accelerated against the negative electrode. The deuterons are discharged on the electrode by capturing electrons and forming atoms D and molecules D₂, which are absorbed on the metal surface constituting a target for incident deuterons, whereby nuclear reactions, fusion of hydrogen nuclei, will occur. In an application of the invention the high voltage electrode (3) is inserted between the cathode (2) and the anode (13), constituting a cell for the electrolysis of heavy water. The cathode (2) and especially the surface layer will be saturated with D₂ and thereby the probability for fusion reactions with deuterons generated by intermittent discharges between the cathode (2) and the high voltage electrode (3) and hitting the cathode, will be considerably increased. The released fusion energy together with the supplied electrical energy can be recovered as high pressure steam.

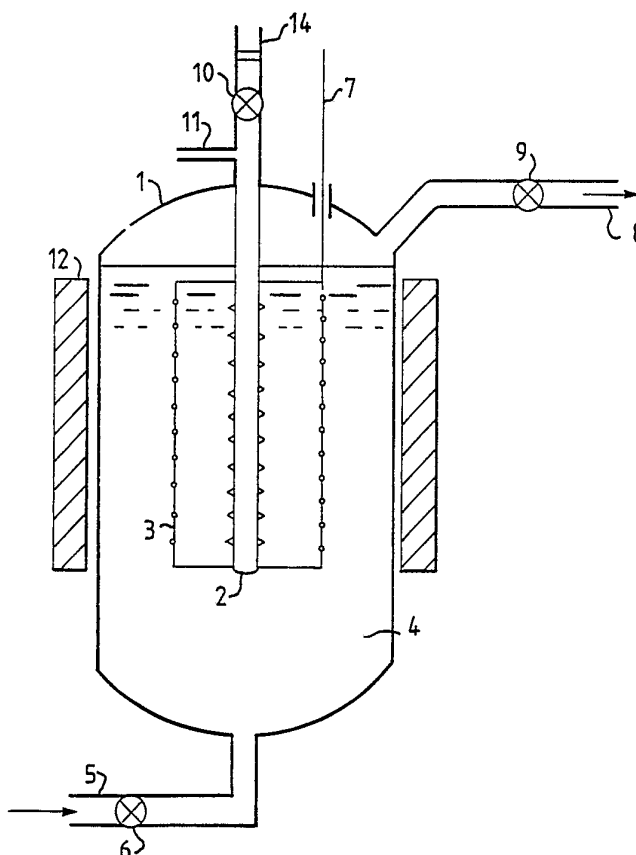

DESIGNATIONS OF "DE"

Until further notice, any designation of "DE" in any international application whose international filing date is prior to October 3, 1990, shall have effect in the territory of the Federal Republic of Germany with the exception of the territory of the former German Democratic Republic.

FOR THE PURPOSES OF INFORMATION ONLY

Codes used to identify States party to the PCT on the front pages of pamphlets publishing international applications under the PCT.

AT	Austria	ES	Spain	MC	Monaco
AU	Australia	FI	Finland	MG	Madagascar
BB	Barbados	FR	France	ML	Mali
BE	Belgium	GA	Gabon	MR	Mauritania
BF	Burkina Fasso	GB	United Kingdom	MW	Malawi
BG	Bulgaria	GR	Greece	NL	Netherlands
BJ	Benin	HU	Hungary	NO	Norway
BR	Brazil	IT	Italy	RO	Romania
CA	Canada	JP	Japan	SD	Sudan
CF	Central African Republic	KP	Democratic People's Republic of Korea	SE	Sweden
CG	Congo	KR	Republic of Korea	SN	Senegal
CH	Switzerland	LI	Liechtenstein	SU	Soviet Union
CM	Cameroon	LK	Sri Lanka	TD	Chad
DE	Germany, Federal Republic of	LU	Luxembourg	TG	Togo
DK	Denmark			US	United States of America

PRODUCTION OF FUSION ENERGY

5 This invention relates to a method of generating energy from the fusion of light atomic nuclei, preferably isotopes of hydrogen, and an apparatus for performing the method.

10 Since many years considerable research has been pursued with the purpose of obtaining fusion of light nuclei, such as deuterons, d, protons, p, and tritons, t, to generate energy in a manageable form for industrial and other use.

15 This fusion research has primarily been concentrated on methods to obtain a magnetic containment of a plasma at a high enough temperature and with such a deuteron density, that a fusion reaction will occur according to the well-known reaction:

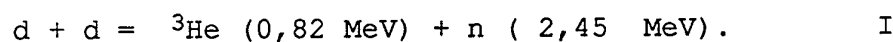

20

In spite of very considerable efforts this line of research has not yet definitively proved that it may result in an industrial process of energy conversion, primarily due to the fact that the necessary temperature and density of the plasma cannot be maintained for a sufficiently long time.

25

The probability that a fusion will occur in a plasma usually is described as a quotient, $T \times n \times \tau$, of the prevailing temperature, $T^\circ\text{K}$, deuteron density, $n \text{ g/m}^3$, and time τ in seconds. In a preferred apparatus according to the invention, the value of $T \times n \times \tau$ can be calculated to be high enough for fusion reactions to occur at a rate of interest for practical use.

30

35 Recently a possibility to obtain so-called "cold fusion", principally an electrolysis of heavy water with a palladium cathode and an anode of platinum or gold, has been proposed and tested - so far without conclusive results. Theoretically it was speculated that fusion reactions under such circumstances, after ab-

sorption of the heavy hydrogen gas in the Pd-metal and formation of D₂-molecules, might occur through the intermediation of so-called quasi-particles (muons) with one negative electron charge but with bigger mass than the electron mass. A muon with larger mass than the electron mass m_e has the ability to bind deuterons 5 d more close in the molecule D₂. It has been calculated that a muon with the mass 5 m_e would decrease the distance between the d nuclei to about 0.15 Å. In this distance the repellant Coulomb potential is about 95 eV and the probability for a penetration 10 through the potential barrier because of quantum mechanical tunnel effects is still low. The probability of tunnel effects would however increase considerably if the deuterons could be given a higher kinetic energy.

15 The method according to the invention is characterized in that it comprises a number of unit processes each complying with at least one of the following functions:

- generating a plasma containing protons, deuterons, or tritons,
- 20 - generating an electrical field for acceleration of said ions towards a target containing or covered with a layer of free or chemically bound heavy hydrogen isotopes,
- continuously regenerating the hydrogen layer on the radiation target, and
- 25 - transferring the heat released by the nuclei fusion to pressurized water for use in known heat power processes.

The apparatus according to the invention comprises a tank with electrolyte inlet and damp outlet with valves, a central tube or 30 rod electrode with flanges or short projections, a surrounding electrode in the shape of a net or a perforated plate, and cables to a high voltage source.

The principle of the method to obtain nuclear fusion according 35 to the invention is to combine mentioned unit processes and there included physical effects to maximize the probability of reactions d + d or p + d to such an extent that industrial energy production is feasible.

The process will be described in detail below with reference to the accompanying drawings, in which:

Figure 1 shows an apparatus according to the invention,
5 and

Figure 2 shows an alternatively designed apparatus according to the invention.

In a tank (1) is provided an electrode system comprising a central electrode 2 in the shape of a rod or a pipe closed at its lower end and made of Pd, Ti or a metal alloy with great capacity of adsorbing hydrogen gas, and an outer electrode 3 in the shape of a tubular net or a perforated plate of platinum. The tank is filled with an electrolyte 4, such as heavy water, D₂O,
15 pure or mixed with H₂O, which is supplied by the conduit 5 with the valve 6.

The outer electrode 3 is connected to the positive pole of a high voltage source by an electrical cable 5 and the central
20 electrode 2 is connected to the negative pole by a cable 14. The high voltage source, e.g. a condenser is discharged by an electric arc between the electrodes 2 and 3. The time of duration, energy delivery and frequency of the spark should be variable within wide limits. Depending of the geometry of the electro-
25 lytic cell an optimum adjustment of these variables is done at the same time as the neutron density in the environment of the tank is an indicator that fusion reactions occur.

The water will be heated and vaporized by the supplied energy
30 and the fusion energy. At a suitable steam pressure the steam is led out through a conduit 8 with a valve 9 and led to the heat exchanger and condenser. Thereafter the water is returned to the tank through the conduit 5 with the valve 6.

35 The central electrode, the tubular cathode 2, is preferably provided with short projections or flanges so that the increased field strength there will promote the formation of discharge sites. The pipe 2 may first be evacuated and then closed by a

valve 10. By coupling a branch pipe 11 to a vacuumeter penetrated deuterium is measured.

In an application of the invention the electrolyte consists of a
5 2 - 10 % by weight suspension in heavy water of magnetic particles e.g. magnetite, Fe_3O_4 , of about 10 nm size. When a current flows through the plasma created by a spark or an electric arc in a high voltage discharge a magnetic field is formed which will considerably increase the apparent density around the
10 plasma track. Thus the current itself will create a magnetic enclosure of the generated deuterons and other charged particles. This effect may be strengthened by surrounding the tank with a magnetic field, whereby the internal fluid pressure in the whole suspension $\text{D}_2\text{O} - \text{Fe}_3\text{O}_4$ can be substantially increased.
15 Of course this effect cannot resist the pressure from the generated steam, which rapidly escapes, but after that the deuteron generating reactions in the spark has occurred.

In a preferred embodiment of the invention the tank 1 is provided with a further electrode 13, functioning as the anode in
20 an electrolytic cell wherein 2 is the cathode for the electrolytic decomposition of D_2O . The electrolyte 4 consists of D_2O and an added acid e.g. D_2SO_4 , or an alkalideuteroxide, e.g. LiOD or KOD . The anode material can be Pt, Ni, or any other material generally used in electrolytic cells for water electrolysis.
25

The cell voltage can be between 2 and 12 V and the concentration of dissolved substances in the heavy water is about 0,1 M , but both higher and lower concentrations may work. The apparent density can also in this case be increased by the addition of suspended magnetic particles of a chemical composition which does
30 not react with the electrolyte.

By the continuous electrolysis the cathode 2 is always saturated
35 with D_2 thereby increasing the probability of fusion reactions by incoming high energy deuterons generated by the high voltage discharge between the electrodes 2 and 3. In this embodiment of the electrode system a diaphragm 15 is inserted to collect and

lead away the generated D_2 through the pipe 16.

High voltage for the electrical discharge in the fluid is applied through the conduit 7 and low voltage for the electro-
5 lysis is applied through the conduit 17 to the anode 13.

List of details:

1. Tank
2. Central electrode, cathode
- 10 3. Outer electrode for high voltage discharge
4. Electrolyte
5. Conduit
6. Valve
7. High voltage conduit
- 15 8. Steam conduit
9. Valve
10. Valve
11. Branch pipe
12. Magnetic field
- 20 13. Electrode
14. Low voltage conduit
15. Diaphragm.
16. Pipe for D_2
17. Low voltage conduit

C l a i m s

1. Method of generating energy from fusion of light atomic
5 nuclei, preferably hydrogen isotopes, **characterized in** that a process comprises several unit processes, each fullfilling at least one of the following functions:
- generating a plasma containing protons, deuterons or tritons,
 - generating an electrical field to accelerate said ions onto a
10 target containing or covered by a layer of atomic or chemically bound hydrogen isotopes
 - continuously renewing the hydrogen layer on the radiation target, and
 - transforming the heat generated by the nuclear fusion reac-
15 tions to pressurized water for use in known heat power processes.
2. Method according to claim 1, **characterized in** that during the acceleration the plasma is encased in a magnetic fluid.
20
3. Method according to claim 1 or 2, **characterized in** that a high voltage of preferably more than 20 kV is discharged through an electrical arc or spark between two electrodes constituting a cathode and an anode immersed in heavy water, D₂O, and that the
25 discharge is continuous or intermittent.
4. Method according to any of the claims 1 - 3, **characterized in** that the heavy water is pressurized, preferably to about 10 MPa.
30
5. Method according to any of the preceeding claims, **characterized in** that the heavy water contains a suspension of solid particles of a ferromagnetic material with a diameter of about 10 nm.
35
6. Method according to any of the preceeding claims, **characterized in** that the discharge occurs in an electrolysis cell for decomposition of heavy water, and that the cathode thereby

also is cathode for the discharge.

7. Apparatus for use of the method according to the preceding claims, **characterized in** that it comprises a tank (1) for electrolyte (4) with inlet (5) for electrolyte, outlet (8) for steam and valves (6,9), a central electrode (2) shaped as a rod or a tube functioning as cathode for the electrical discharge and provided with flanges or short projections, and a surrounding outer electrode, anode, (3) in the shape of a net or a perforated plate, and connections (7,14) to a high voltage source.

8. Apparatus according to claim 7, **characterized in** that the central electrode (2) consists of palladium or titan, the outer electrode (3) of platinum and the electrolyte (4) of heavy water, D_2O , or an alkali metal deuterioxide or D_2SO_4 dissolved in heavy water.

9. Apparatus according to claim 7 or 8, **characterized in** that a further tubular electrode (13) is arranged as anode for the decomposition electrolysis having connections (17,18) between the respective electrodes (13,2) and a low voltage source, and that a diaphragm (15) with an outlet pipe (16) for D_2 is surrounding the electrode (2).

10. Apparatus according to any of the claims 7 - 9, **characterized in** that particles of a ferromagnetic material with a diameter of about 10 nm are suspended in the electrolyte (4), and that the tank (1) is surrounded by a magnetic field (12).

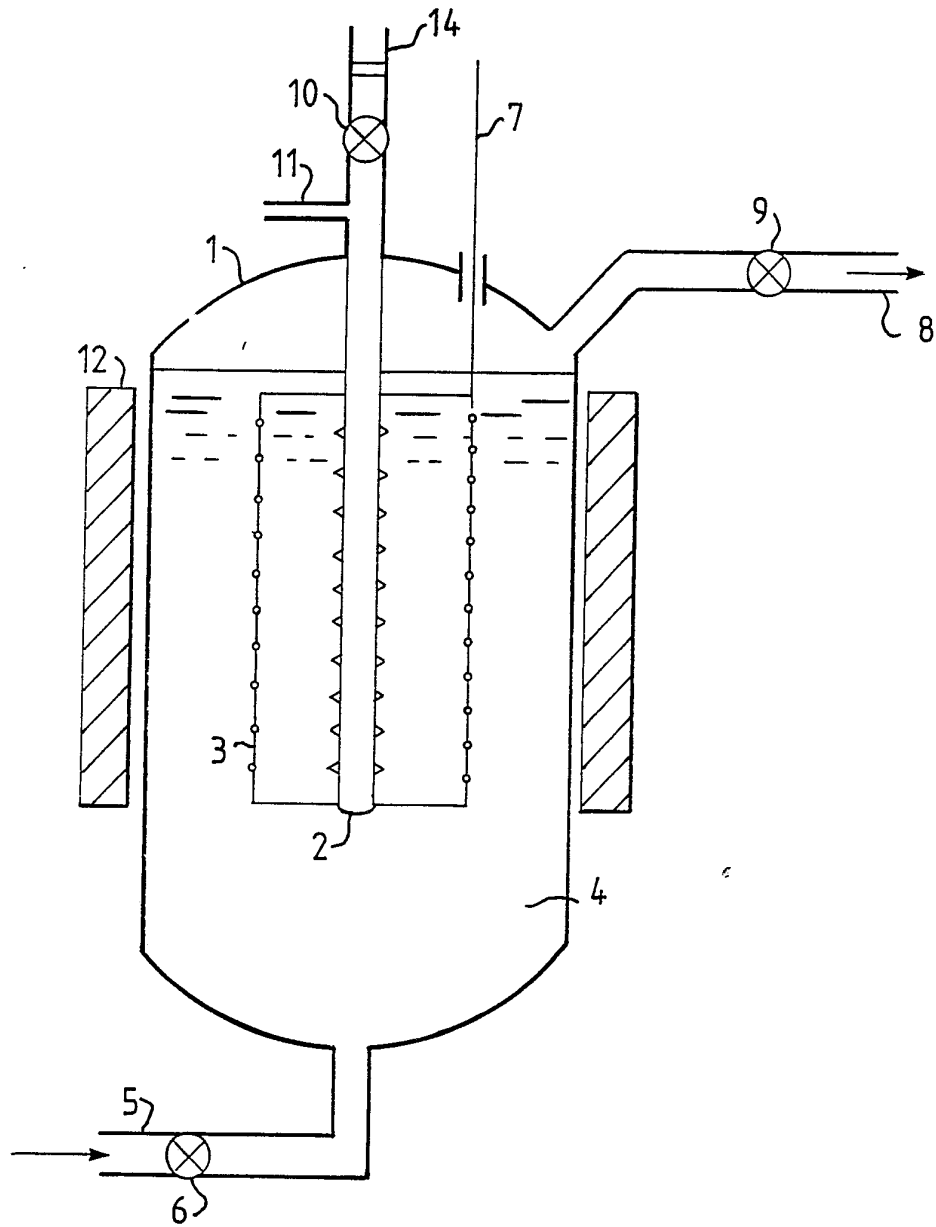

FIG. 1

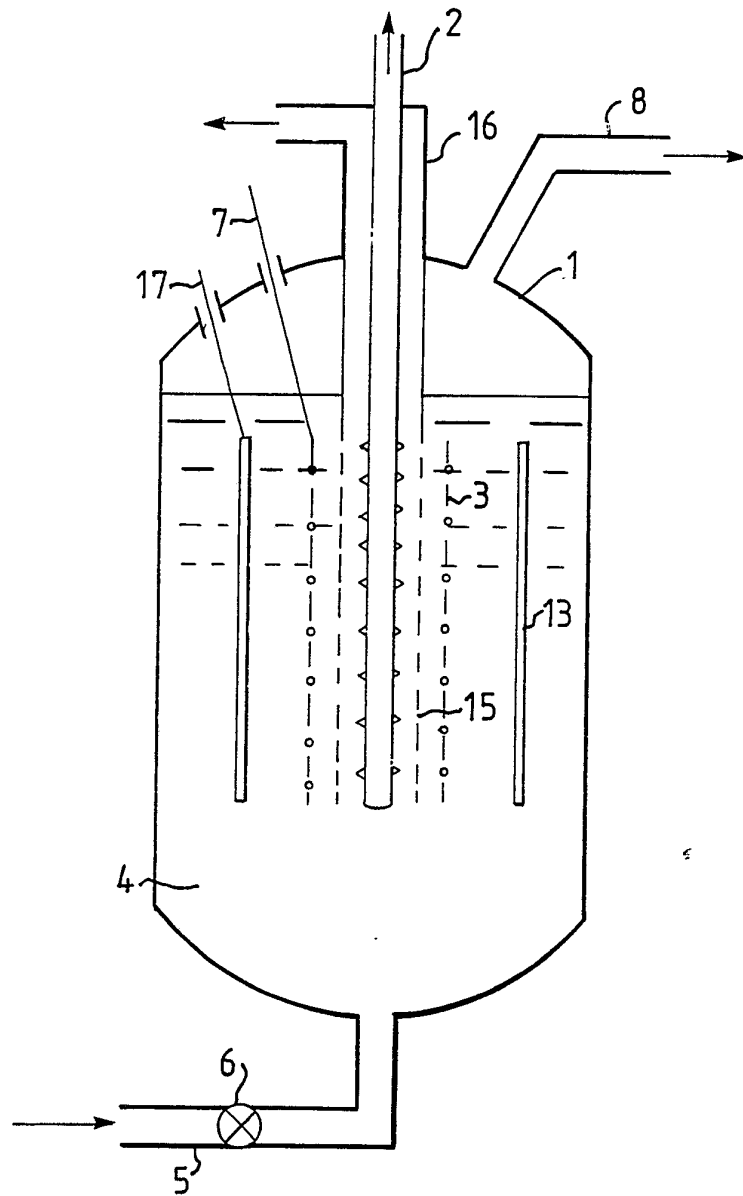

FIG. 2

INTERNATIONAL SEARCH REPORT

International Application No **PCT/SE 90/00320**

I. CLASSIFICATION OF SUBJECT MATTER (if several classification symbols apply, indicate all) ⁶				
According to International Patent Classification (IPC) or to both National Classification and IPC				
IPC5: G 21 B 1/00				
II. FIELDS SEARCHED				
Minimum Documentation Searched ⁷				
Classification System	Classification Symbols			
IPC5	G 21 B			
Documentation Searched other than Minimum Documentation to the Extent that such Documents are Included in Fields Searched ⁸				
SE,DK,FI,NO classes as above				
III. DOCUMENTS CONSIDERED TO BE RELEVANT⁹				
Category *	Citation of Document, ¹¹ with indication, where appropriate, of the relevant passages ¹²	Relevant to Claim No. ¹³		
X	US, A, 4759894 (MCCORKLE) 26 July 1988, see column 10, line 49 - column 11, line 48; figure 3; claims 1-3,5	1-4,7		
Y	--	6,8		
X	US, A, 3437862 (W.W. SALISBURY) 8 April 1969, see claims 1,6,26	1		
X	US, A, 2728877 (H.F. FISCHER) 27 December 1955, see column 4, line 32 - line 36; claim 1	1		
X	US, A, 4836972 (BUSSARD ET AL) 6 June 1989, see claims 1,10	1		
<table style="width: 100%; border: none;"> <tr> <td style="width: 50%; vertical-align: top;"> <p>* Special categories of cited documents:¹⁰</p> <p>"A" document defining the general state of the art which is not considered to be of particular relevance</p> <p>"E" earlier document but published on or after the international filing date</p> <p>"L" document which may throw doubts on priority claim(s) or which is cited to establish the publication date of another citation or other special reason (as specified)</p> <p>"O" document referring to an oral disclosure, use, exhibition or other means</p> <p>"P" document published prior to the international filing date but later than the priority date claimed</p> </td> <td style="width: 50%; vertical-align: top;"> <p>"T" later document published after the international filing date or priority date and not in conflict with the application but cited to understand the principle or theory underlying the invention</p> <p>"X" document of particular relevance, the claimed invention cannot be considered novel or cannot be considered to involve an inventive step</p> <p>"Y" document of particular relevance, the claimed invention cannot be considered to involve an inventive step when the document is combined with one or more other such documents, such combination being obvious to a person skilled in the art.</p> <p>"&" document member of the same patent family</p> </td> </tr> </table>			<p>* Special categories of cited documents:¹⁰</p> <p>"A" document defining the general state of the art which is not considered to be of particular relevance</p> <p>"E" earlier document but published on or after the international filing date</p> <p>"L" document which may throw doubts on priority claim(s) or which is cited to establish the publication date of another citation or other special reason (as specified)</p> <p>"O" document referring to an oral disclosure, use, exhibition or other means</p> <p>"P" document published prior to the international filing date but later than the priority date claimed</p>	<p>"T" later document published after the international filing date or priority date and not in conflict with the application but cited to understand the principle or theory underlying the invention</p> <p>"X" document of particular relevance, the claimed invention cannot be considered novel or cannot be considered to involve an inventive step</p> <p>"Y" document of particular relevance, the claimed invention cannot be considered to involve an inventive step when the document is combined with one or more other such documents, such combination being obvious to a person skilled in the art.</p> <p>"&" document member of the same patent family</p>
<p>* Special categories of cited documents:¹⁰</p> <p>"A" document defining the general state of the art which is not considered to be of particular relevance</p> <p>"E" earlier document but published on or after the international filing date</p> <p>"L" document which may throw doubts on priority claim(s) or which is cited to establish the publication date of another citation or other special reason (as specified)</p> <p>"O" document referring to an oral disclosure, use, exhibition or other means</p> <p>"P" document published prior to the international filing date but later than the priority date claimed</p>	<p>"T" later document published after the international filing date or priority date and not in conflict with the application but cited to understand the principle or theory underlying the invention</p> <p>"X" document of particular relevance, the claimed invention cannot be considered novel or cannot be considered to involve an inventive step</p> <p>"Y" document of particular relevance, the claimed invention cannot be considered to involve an inventive step when the document is combined with one or more other such documents, such combination being obvious to a person skilled in the art.</p> <p>"&" document member of the same patent family</p>			
IV. CERTIFICATION				
Date of the Actual Completion of the International Search	Date of Mailing of this International Search Report			
13th August 1990	1990 -08- 1 6			
International Searching Authority	Signature of Authorized Officer			
SWEDISH PATENT OFFICE	RUNE BENGTTSSON <i>Rune Bengtsson</i>			

III. DOCUMENTS CONSIDERED TO BE RELEVANT (CONTINUED FROM THE SECOND SHEET)		
Category *	Citation of Document, with indication, where appropriate, of the relevant passages	Relevant to Claim No
X	US, A, 4793961 (EHLERS ET AL) 27 December 1988, see claims 1,9-11 --	1
X	US, A, 4853173 (STENBACKA) 1 August 1989, see abstract; claims 1,9-10 --	1
Y	Research News, Vol., April 1989 Robert Pool: "Fusion Followup: Confusion Abounds ", see page 27, column 1, line 35 - line 52 --	6,8
Y	L Recherche, Vol. 20, June 1989 Christian Amatore: "La fusion froide aura-t-elle lieu?" "; ; figure 1 / -- -----	6,8

ANNEX TO THE INTERNATIONAL SEARCH REPORT
ON INTERNATIONAL PATENT APPLICATION NO.PCT/SE 90/00320

This annex lists the patent family members relating to the patent documents cited in the above-mentioned international search report. The members are as contained in the Swedish Patent Office EDP file on 90-06-27. The Swedish Patent Office is in no way liable for these particulars which are merely given for the purpose of information.

Patent document cited in search report	Publication date	Patent family member(s)	Publication date
US-A- 4759894	88-07-26	CA-A- 1213083	86-10-21
		EP-A- 0114356	84-08-01
		JP-A- 59138983	84-08-09

US-A- 3437862	69-04-08	NONE	

US-A- 2728877	55-12-27	NONE	

US-A- 4836972	89-06-06	AU-B- 515071	81-03-12
		AU-D- 3211177	79-07-05
		CA-A- 1115862	82-01-05
		DE-A-C- 2758866	78-07-06
		FR-A-B- 2376497	78-07-28
		GB-A- 1555840	79-11-14
		JP-C- 1248123	85-01-16
		JP-A- 53102500	78-09-06
		JP-B- 59025194	84-06-15
US-A- 4363775	82-12-14		

US-A- 4793961	88-12-27	NONE	

US-A- 4853173	89-08-01	AU-D- 6724287	87-07-01
		EP-A- 0280684	88-09-07
		SE-B-C- 450060	87-06-01
		WO-A- 87/03416	87-06-04