

May 31, 1938.

F. A. HERMAN

2,118,974

SPRING WEB SEAT CONSTRUCTION

Filed Nov. 12, 1937

2 Sheets-Sheet 1

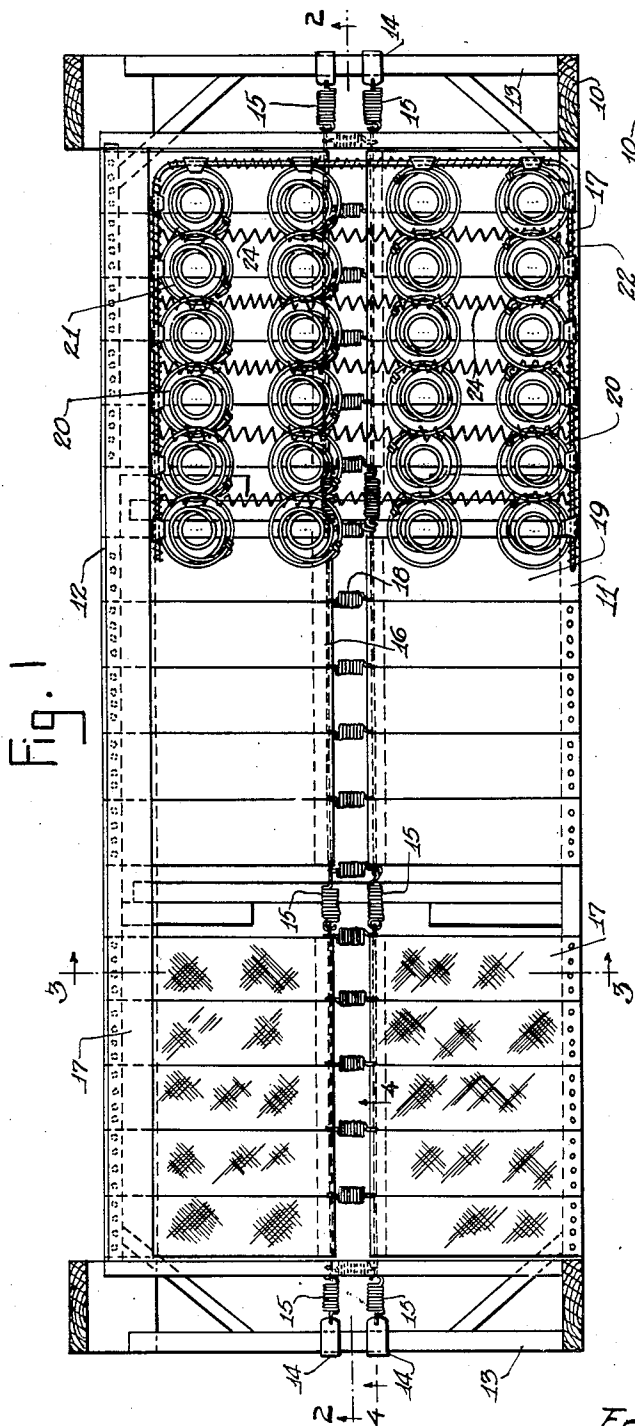

Fig. 1

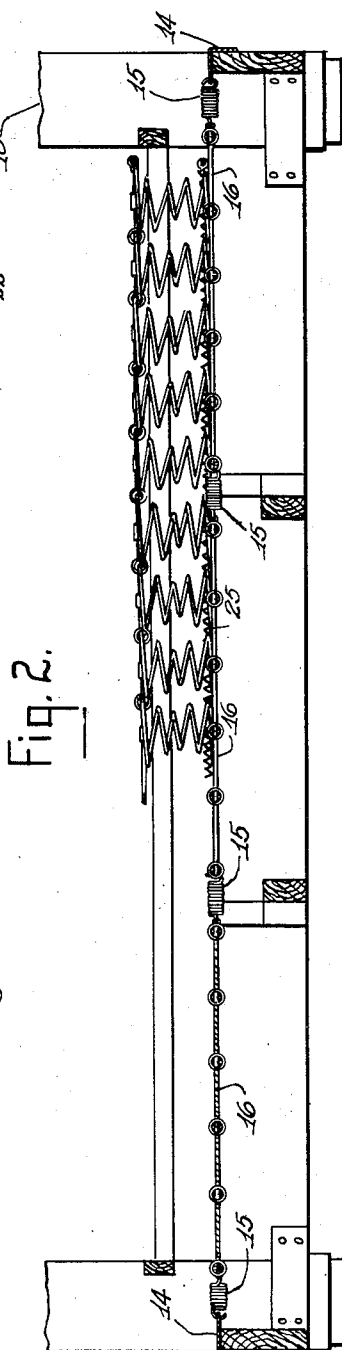

Fig. 2.

Inventor  
Fredd A. Herman  
By James R. McKnight  
Att'y

May 31, 1938.

F. A. HERMAN

2,118,974

SPRING WEB SEAT CONSTRUCTION

Filed Nov. 12, 1937

2 Sheets-Sheet 2

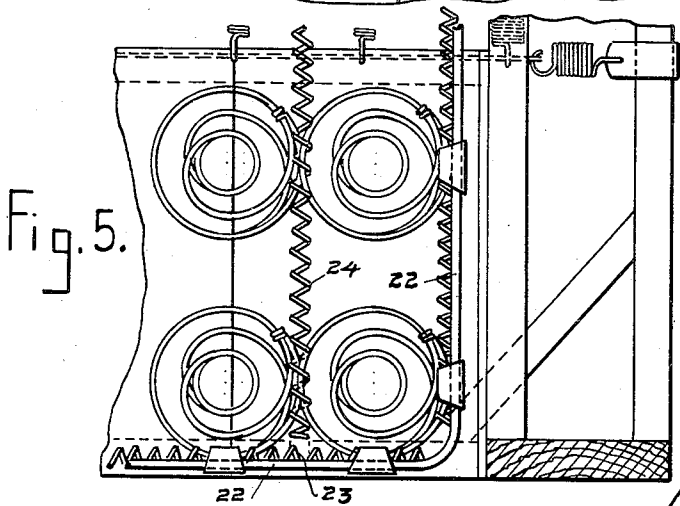
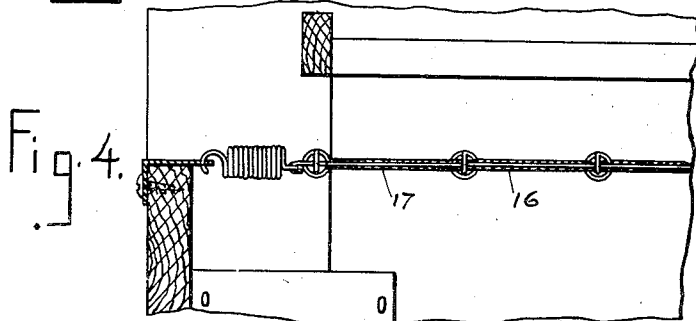
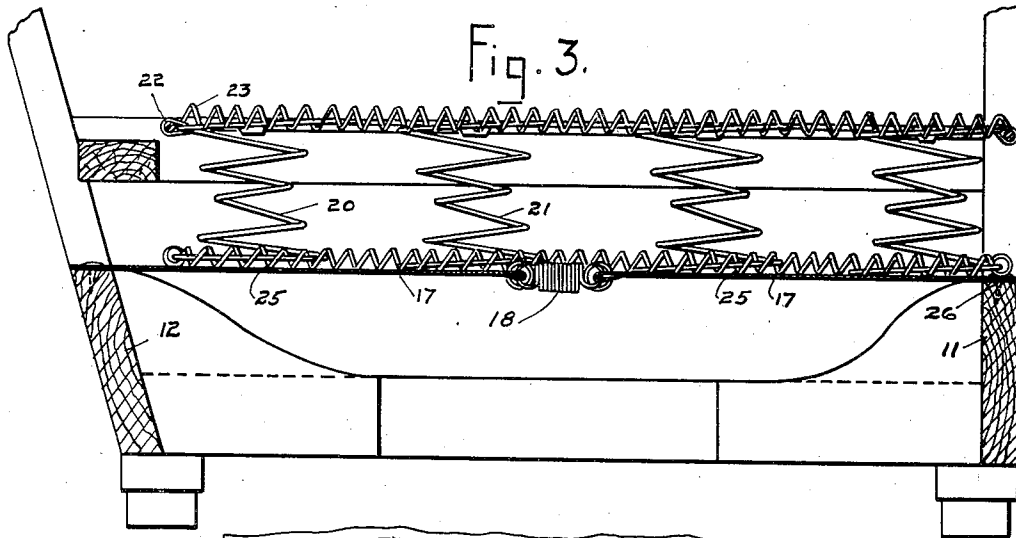

Inventor  
Fredd. A. Herman  
By James R. McKnight.  
Att'y

# UNITED STATES PATENT OFFICE

2,118,974

## SPRING WEB SEAT CONSTRUCTION

Fredd A. Herman, Chicago, Ill.

Application November 12, 1937, Serial No. 174,171

2 Claims. (Cl. 155—179)

My invention relates to spring web seat construction and is particularly adapted for use with chairs, davenport and the like.

Among the objects of my invention is to create a triple action seat construction having a greater number of coil springs of substantially low height interwoven with coiled wire in combination with webbing supported by helical coils—thereby providing a construction affording maximum comfort; to supply a seat construction eliminating the use of twine or rope; to provide a seat construction simple and economical of manufacture and assembly, and sturdy and lasting in operation, use and wear; to create a construction in which a straight front line is acquired and maintained, and in which side sway and sag is eliminated; to provide a seat construction having vertical, lateral and longitudinal resiliency, and such other objects, advantages and capabilities as will later more fully appear and which are inherently possessed by my invention.

While I have shown in the accompanying drawings preferred embodiments of my invention, yet I wish it understood that the same are susceptible of modification and change without departing from the spirit of my invention.

Referring to the drawings, Fig. 1 is a plan view of a preferred embodiment of my invention as applied to a davenport frame with a part in section showing the details of my construction; Fig. 2 is a longitudinal cross section on line 2—2 of Fig. 1; Fig. 3 is a transverse cross section on line 3—3 of Fig. 1, on a somewhat larger scale; Fig. 4 is a detailed cross section on line 4—4 of Fig. 1 and Fig. 5 is an enlarged plan section of the right hand front corner as shown in Fig. 1.

Referring to the embodiment selected to illustrate my invention, a frame 10 of wood, metal or any other suitable material has a front rail 11, a back rail 12 and oppositely disposed side rails 13.

A pair of spaced metal hangers 14 are attached to the side rails 13 preferably on either side of the centers thereof. A helical expansion spring 15 is attached on one end to each of said hangers 14 and on its other end to a reach rod 16. The spaced reach rods 16 extend laterally and inwardly and each of their inner ends is attached to another helical spring 15. In Fig. 1 where three units of my construction are used to form a davenport, the inner reach rods 16 extend between the inner helical springs 15 as shown.

A webbing 17 of suitable jute material or the like has its inner end bent back and sewed on

itself or is otherwise suitably attached to each of the reach rods 16 and extends longitudinally to its other end where it is attached to the front rail 11 or back rail 12 by tacks or other suitable fastening means. My invention contemplates either a single webbing between each reach rod 16 and each front or back rail, or a plurality of spaced webbings between each reach rod and each rail. A plurality of spaced longitudinally extending helical expansion springs 18 are attached on opposite ends to each of the spaced reach rods 16 to provide resiliency to the webbing construction or base 19 in a longitudinal as well as lateral plane.

A spring unit 20 is positioned over the webbing base 19, and its front end lies on the front rail 11.

The spring unit 20 comprises a plurality of compression tension coil springs 21 arranged so that they are substantially contiguous laterally, and spaced longitudinally. My coils 21 are substantially low in height and being preferably three and one-half to four inches in normal height are approximately one-half the height of the coils heretofore used in spring seat constructions. Because of the low height of my coils the need or use of twine or rope to tie the coils is eliminated. My coils also do away with sliding and side sway.

Surrounding the coils 21 at the top portions thereof is a frame 22, preferably of spring steel or other suitable material. A coil wire 23 at each of the outer edges of the frame 22 interweaves to connect the frame and the coils 21 adjacent the frame. A plurality of coil wires 24 extend longitudinally and each interweaves to connect adjacent coils 21.

There is no frame at the bottom portion of my spring unit 20, but a coil wire 25 on each outer side interweaves to connect outer coils 21, and longitudinally extending coil wires 24 interweave to connect the bottom portions of adjacent coils 21.

When spring unit 20 is positioned over the webbing base 19, the front end of the spring unit lies on the front rail 11 of the frame 10, and tacks 26 passing through loops of adjacent coil wire 25 and then through webbing 17 provide firmness in front, a straight front line and eliminate back and front sway.

It is also within the contemplation of my invention that clips may be used instead of coil wire to attach the outer coils to the frame.

My spring unit 20 may be of a desired size

depending upon its use for a single seat, or davenport having a plurality of seats.

My seat construction calls for substantially double the number of coils previously used in a given surface, and in combination with my webbing base gives comfort, strength and style heretofore unknown.

Having thus described my invention, I claim:

1. In a spring seat web construction a frame, said frame having front, back and oppositely disposed side rails, a pair of spaced laterally extending helical expansion springs attached at their outer ends to each of the oppositely disposed side rails, a pair of spaced reach rods, each of said reach rods having opposite ends attached to one of said laterally extending helical springs, a plurality of webbings, each of said webbings having an inner end attached to one of said reach

rods, and an outer end attached to a front or back rail, and a plurality of spaced longitudinally extending helical expansion springs having opposite ends attached to said spaced reach rods.

2. A spring seat construction comprising a frame, a plurality of spaced reach rods attached to the frame by laterally extending helical expansion springs, said spaced reach rods attached to each other by longitudinally extending helical expansion springs, webbing extending between and attached to said frame and said reach rods, in combination with a spring unit attached to said frame and supported on said webbing, said spring unit having a substantial number of interconnected compression coils of substantially low height, said seat construction having lasting vertical, lateral and longitudinal resiliency.

FREDD A. HERMAN.