

Sept. 18, 1934.

P. M. MILLER

1,974,363

VALVE SPRING COMPRESSOR

Filed Oct. 25, 1933

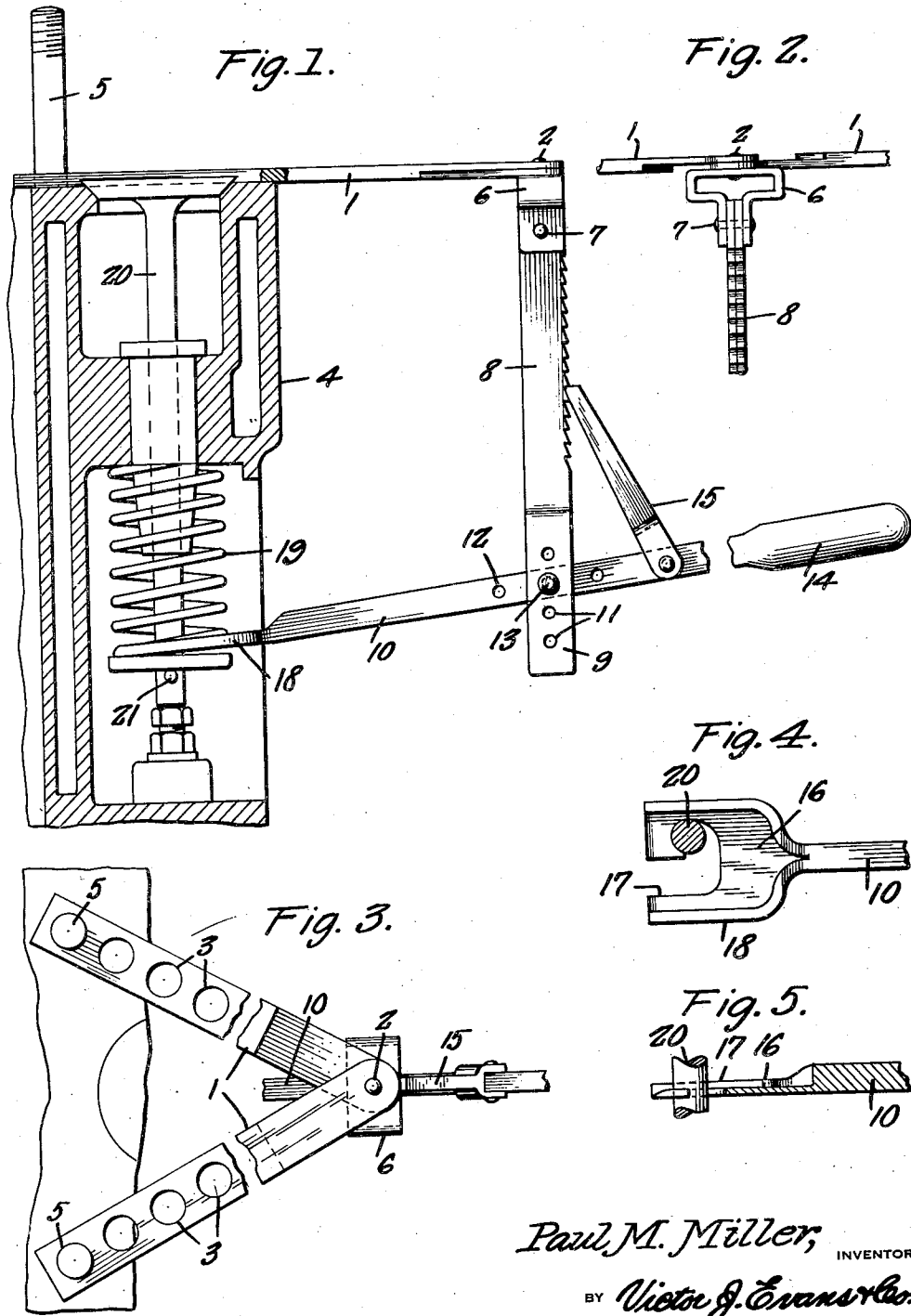

WITNESS: *P. B. Michay*

Paul M. Miller, INVENTOR

BY *Victor J. Evans & Co.* ATTORNEY

UNITED STATES PATENT OFFICE

1,974,363

VALVE SPRING COMPRESSOR

Paul M. Miller, Bloomfield, N. J.

Application October 25, 1933, Serial No. 695,169

1 Claim. (Cl. 29—86.3)

This invention relates to valve spring tools and has for the primary object the provision of a device of the above stated character which is simple and convenient to operate and self-retaining to maintain a valve spring compressed so that the operator may have use of either or both hands to remove and replace a key to the valve and the device also may successfully operate on several valves from a single adjustment thereof to the engine block.

With these and other objects in view this invention consists in certain novel features of construction, combination and arrangement of parts to be hereinafter more fully described and claimed.

For a complete understanding of my invention, reference is to be had to the following description and accompanying drawing, in which

Figure 1 is a side elevation, partly in section, illustrating a valve spring tool constructed in accordance with my invention and showing the same applied to a valve and cylinder block of an engine.

Figure 2 is a detail view illustrating the connection between a pair of supporting arms and a rack bar.

Figure 3 is a fragmentary plan view illustrating the supporting arms.

Figure 4 is a fragmentary plan view illustrating the jaw carried by the operating lever.

Figure 5 is a fragmentary sectional view illustrating the same applied to a valve stem.

Referring in detail to the drawing, the numeral 1 indicates a pair of supporting arms connected at one end by a pivot 2 and provided with a series of openings 3 whereby said arms may be positioned upon a cylinder block 4 of an engine with the stud bolts 5 employed for connecting the cylinder head to the block passing through certain of the openings. A head 6 is journaled upon the pivot 2 and includes spaced ears 7 between which is pivoted one end of a rack bar 8 and the lower end of the latter is bifurcated to provide spaced ears 9 between which operates a lever 10. The ears 9 are provided with a series of aligned openings 11 and the lever 10 is provided with a series of openings 12. A pivot pin 13 is employed for connecting the lever 10 to the ears by extending through apertures 11 and 12. The arrangement of the apertures 11 and 12 permits the lever to be raised and lowered and moved towards and from the block 4. The outer end of the lever carries a handle 14 and also a pivoted dog 15 adapted to co-act with the teeth of the rack bar for holding the lever in adjusted position. The inner end of the lever is flattened to form a jaw 16 provided with a key-hole slot 17, the latter opening out-

wardly through the end of the jaw. Flanges 18 are formed on the sides of the jaw and one end of the latter. These flanges project above the upper face of the jaw and cooperate with said face in receiving the lower convolution of a valve spring 19 employed for seating the valve 20 of the cylinder block 4.

During the operation of the tool and after the application of the arms 1 to the block, the jaw is placed to receive the stem of the valve in the slot 17, as shown in Figure 4, with the lower convolution of the spring engaging the upper face of the jaw between the flanges 18. A downward movement of the handle 14 compresses the spring and the lever may be held in this position by the dog engaging the teeth of the rack bar. The operator's hands are then free to remove the key 21 from the valve stem. With the key removed from the valve stem, the valve may then be readily moved out of the block 4. After the replacement of the valve and key the spring 19 may be released by disengaging the dog from the rack bar.

While I have shown and described the preferred embodiment of my invention, it will be understood that minor changes in construction, combination and arrangement of parts may be made without departing from the spirit and scope of my invention, as claimed.

Having described the invention, I claim:

A valve tool comprising supporting arms having openings to receive head bolts of an engine, a pivot connecting the arms in diverging relation, a head journaled to the pivot, a rack bar pivoted to the head, a lever pivotally and adjustably connected to the rack bar, a handle for the lever, a dog pivoted to the lever for coaction with the rack bar, said lever having one end flattened and provided with a key hole slot to form a jaw to receive a valve stem in the slot and to engage a convolution of a valve spring with its upper face, and a flange on the flattened portion to cooperate with the upper face thereof in forming the seat for the convolution of the spring.

PAUL M. MILLER.

100

105

110