



(12) **United States Design Patent**
Armstrong

(10) **Patent No.:** **US D950,607 S**
(45) **Date of Patent:** **** May 3, 2022**

(54) **AXIAL FLOW AIR/OIL SEPARATOR**

OTHER PUBLICATIONS

(71) Applicant: **Gary D. Armstrong**, Loomis, CA (US)

Armstrong Racing Engineering, Dry Sump Cast Oil Tank A-Series Tanks, (Site visited Sep. 9, 2021), Drysump.com website, URL:<https://www.drysump.com/index.php/oil-tanks-vent-cans/are-new-cast-tank> (Year: 2021).*

(72) Inventor: **Gary D. Armstrong**, Loomis, CA (US)

Ruein, Ruien Polish Baffled Universal Aluminum Oil Catch Can Reservoir Tank Black, (first available date Mar. 12, 2017), Amazon.com, URL:<https://www.amazon.com/Ruien-0046-Universal-Aluminum-Reservoir/dp/B06XK9PTP7> (Year: 2017).*

(**) Term: **15 Years**

(21) Appl. No.: **29/751,239**

* cited by examiner

(22) Filed: **Sep. 18, 2020**

(51) **LOC (13) Cl.** **15-01**

(52) **U.S. Cl.**

USPC **D15/5**

(58) **Field of Classification Search**

USPC D13/184; D15/1-7, 148, 150

CPC F01M 13/04; F01M 2013/0422; F01M

2013/0427; F01M 2013/0438; F01M

2013/0444; B01D 35/02; B04B 5/12;

F01L 1/047

See application file for complete search history.

Primary Examiner — Calvin E Vasant

Assistant Examiner — Mark T. Philipps

(74) *Attorney, Agent, or Firm* — Quickpatents, LLC; Kevin Prince

(57) **CLAIM**

The ornamental design for an axial flow air/oil separator, as shown and described.

(56) **References Cited**

DESCRIPTION

U.S. PATENT DOCUMENTS

D215,882	S	*	11/1969	Svenson	D15/7
D244,681	S	*	6/1977	Bell	D15/7
5,277,154	A		1/1994	McDowell		
7,445,653	B2		11/2008	Trautmann		
D679,733	S	*	4/2013	Armstrong	D15/5
D715,841	S	*	10/2014	Comben	D15/143
D742,419	S	*	11/2015	Armstrong	D15/5
9,260,993	B1		2/2016	Mainiero		
D796,554	S	*	9/2017	Armstrong	D15/5
D890,814	S	*	7/2020	Armstrong	D15/5
2008/0257161	A1	*	10/2008	Read	B01D 46/2411 96/220
2012/0031276	A1	*	2/2012	Meusel	F01L 1/047 96/400
2017/0320070	A1	*	11/2017	Bovensiep	B04C 5/13

FIG. 1 is a perspective view of an axial flow air/oil separator, showing my new design;

FIG. 2 is a perspective view of FIG. 1 with the axial separator element removed and placed alongside the main body for clarity;

FIG. 3 is a front elevational view of FIG. 2;

FIG. 4 is a rear elevation view of FIG. 2;

FIG. 5 is a left-side elevation view of FIG. 2;

FIG. 6 is a right-side elevation view of FIG. 2;

FIG. 7 is a top plan view of FIG. 2; and,

FIG. 8 is a bottom plan view of FIG. 2.

The broken lines depict portions of the axial flow air/oil separator that form no part of the claimed design.

1 Claim, 6 Drawing Sheets

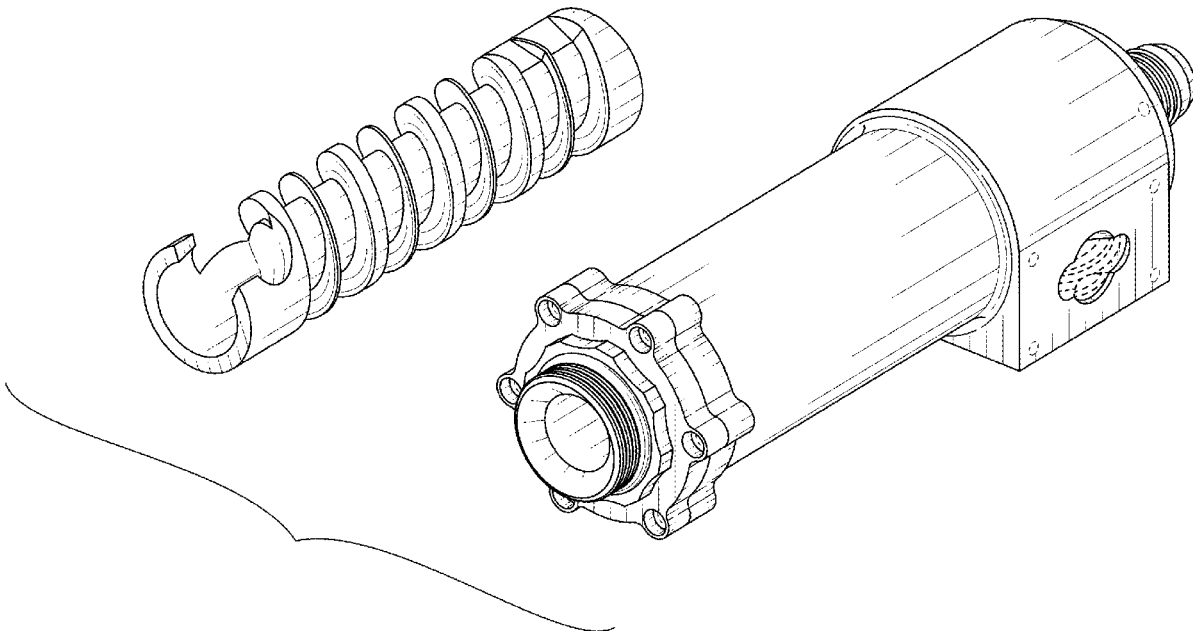

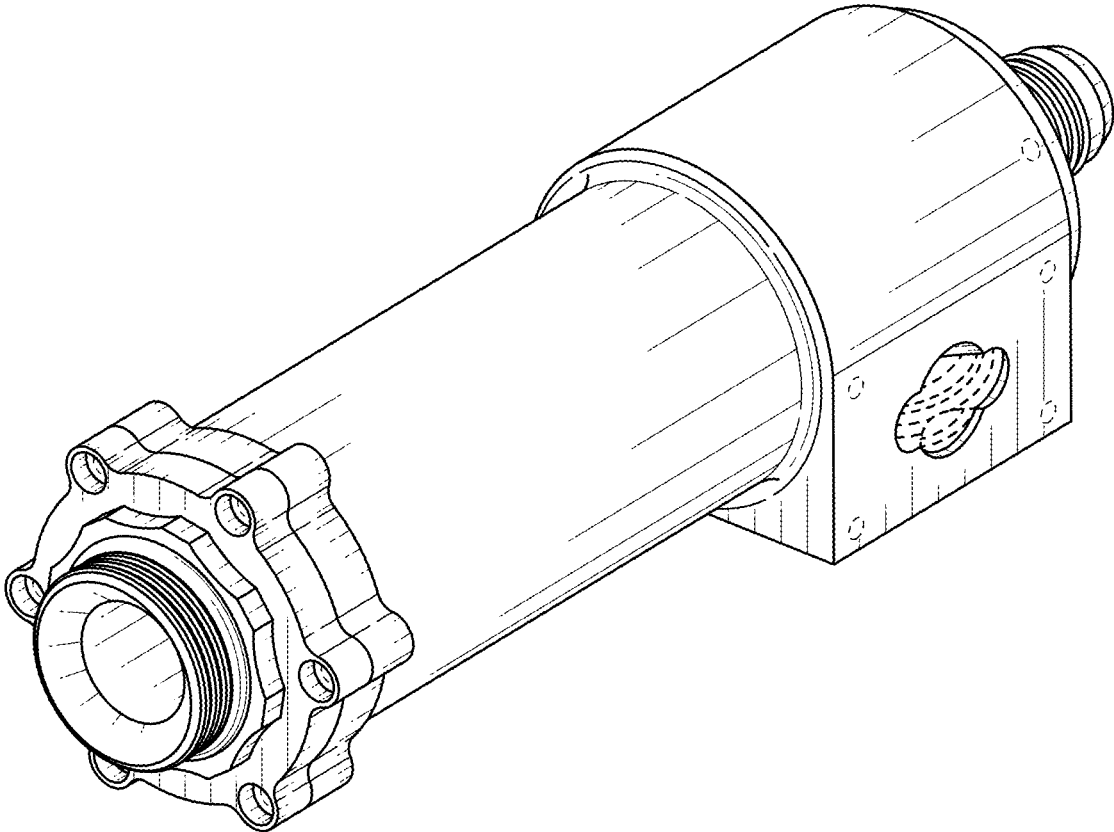

FIG. 1

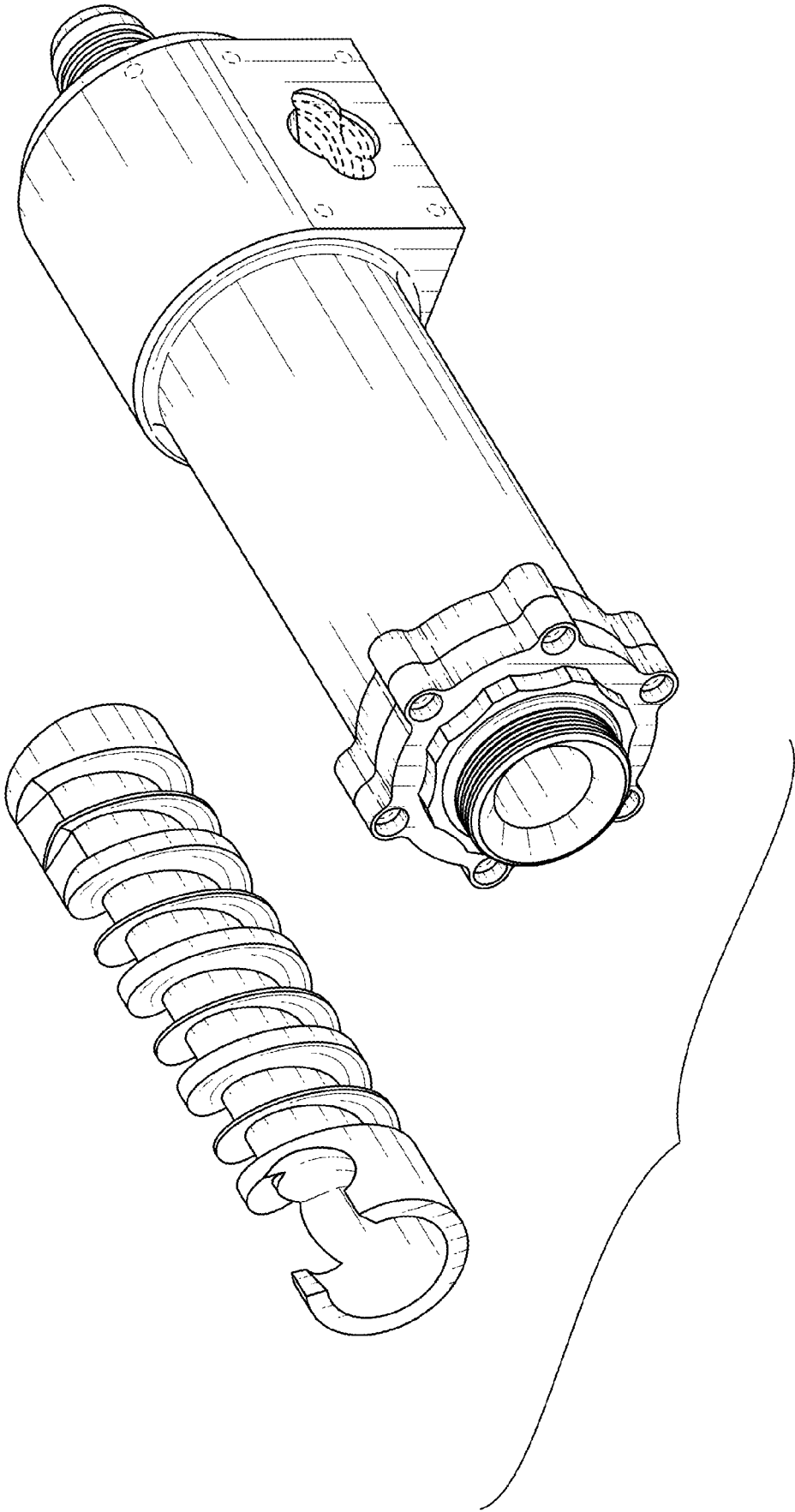

FIG. 2

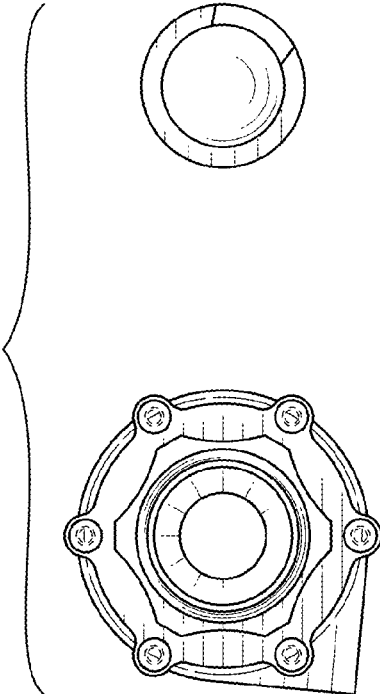

FIG. 3

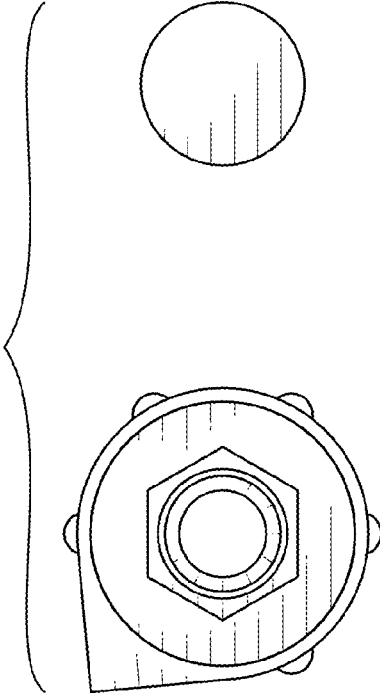

FIG. 4

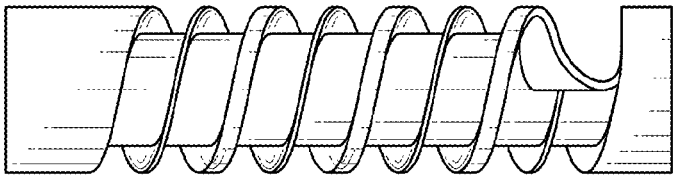
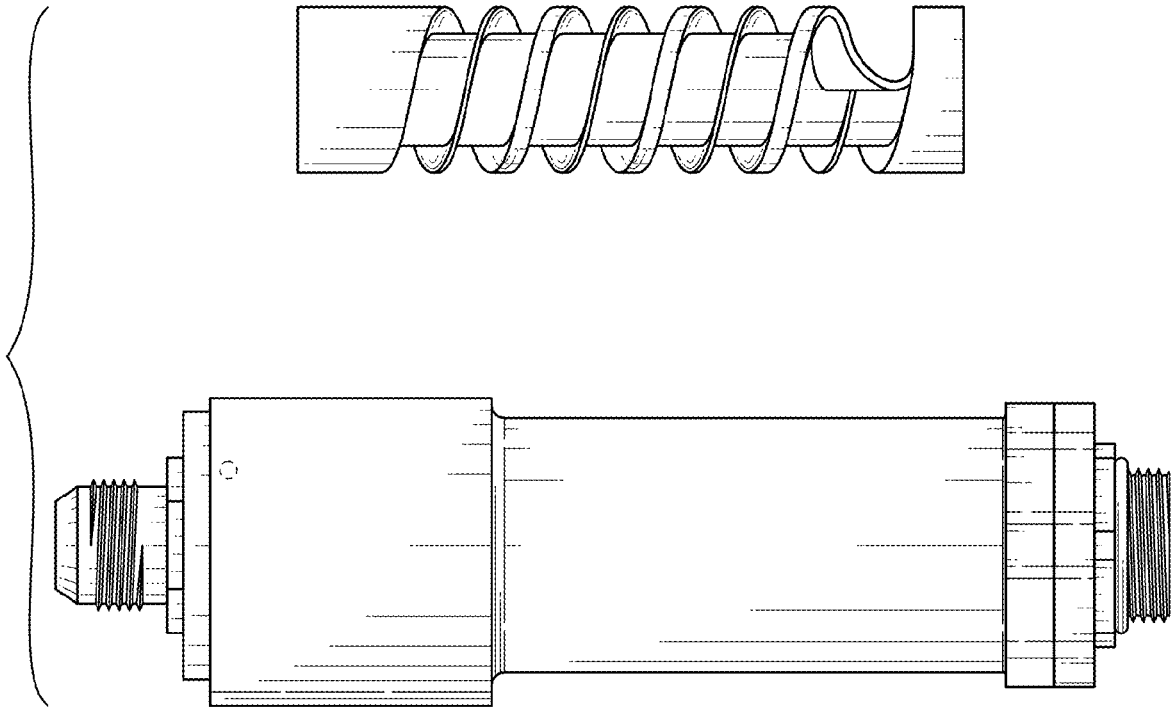

FIG. 5

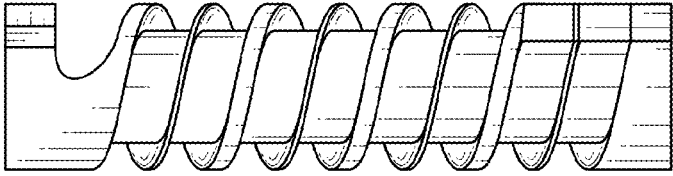
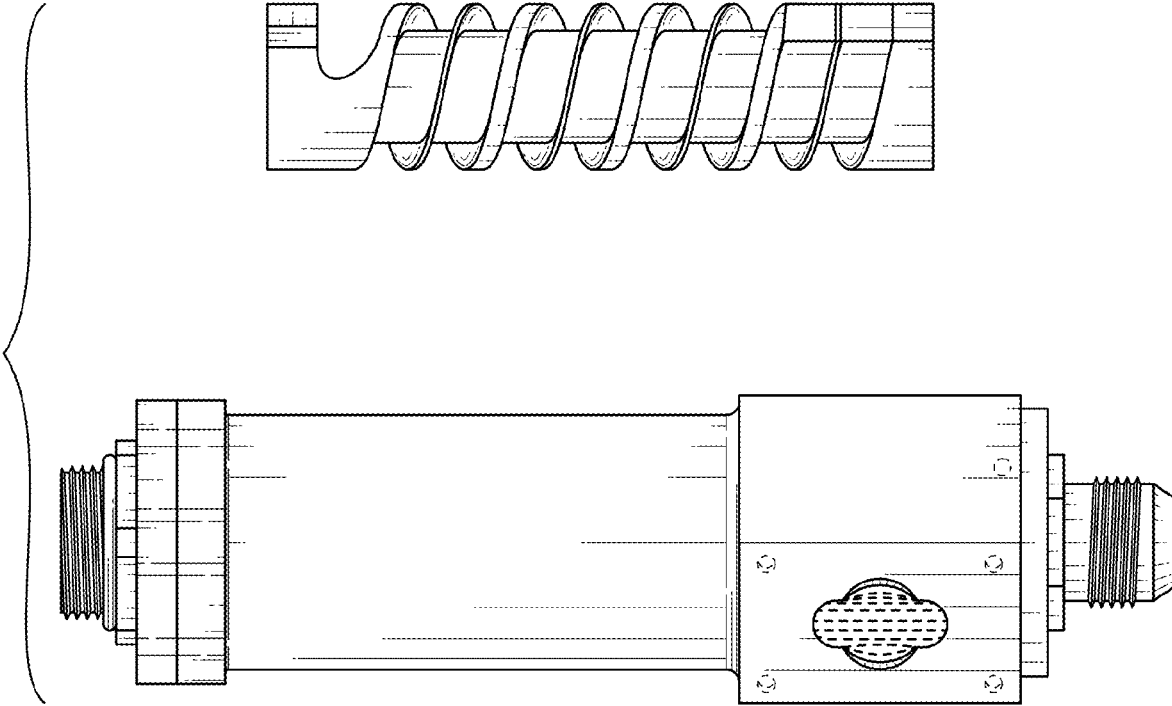

FIG. 6

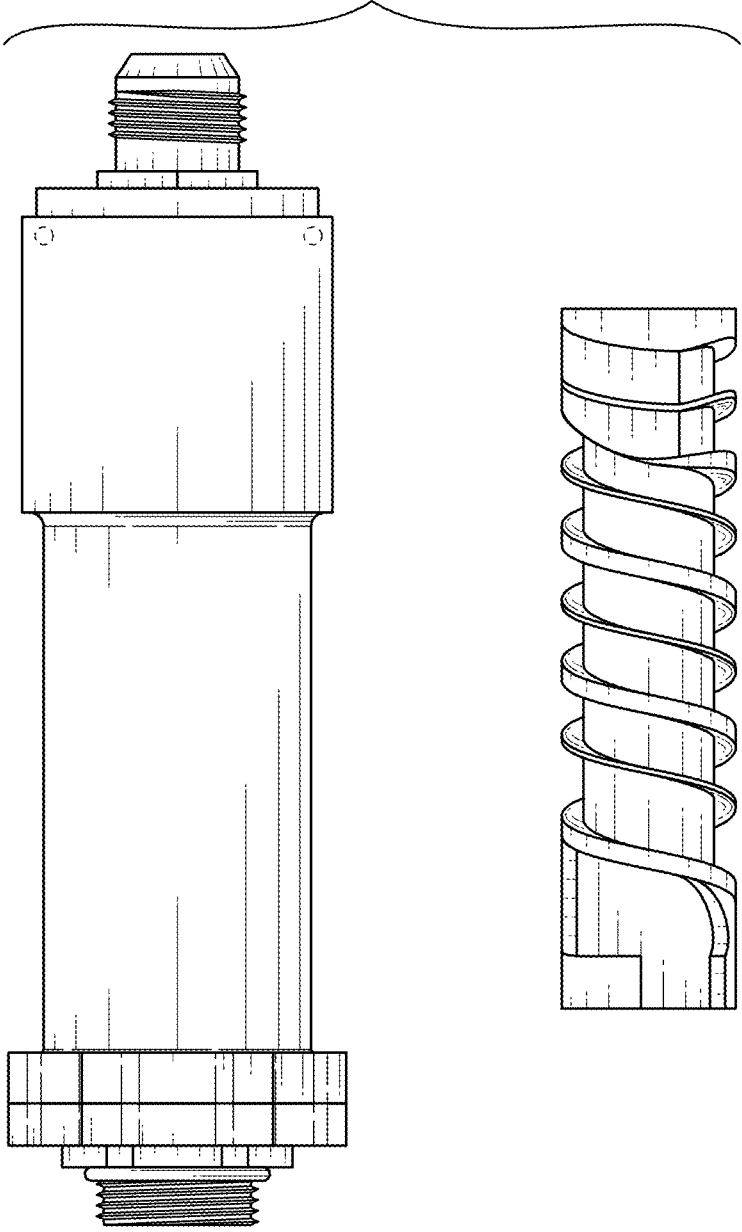

FIG. 7

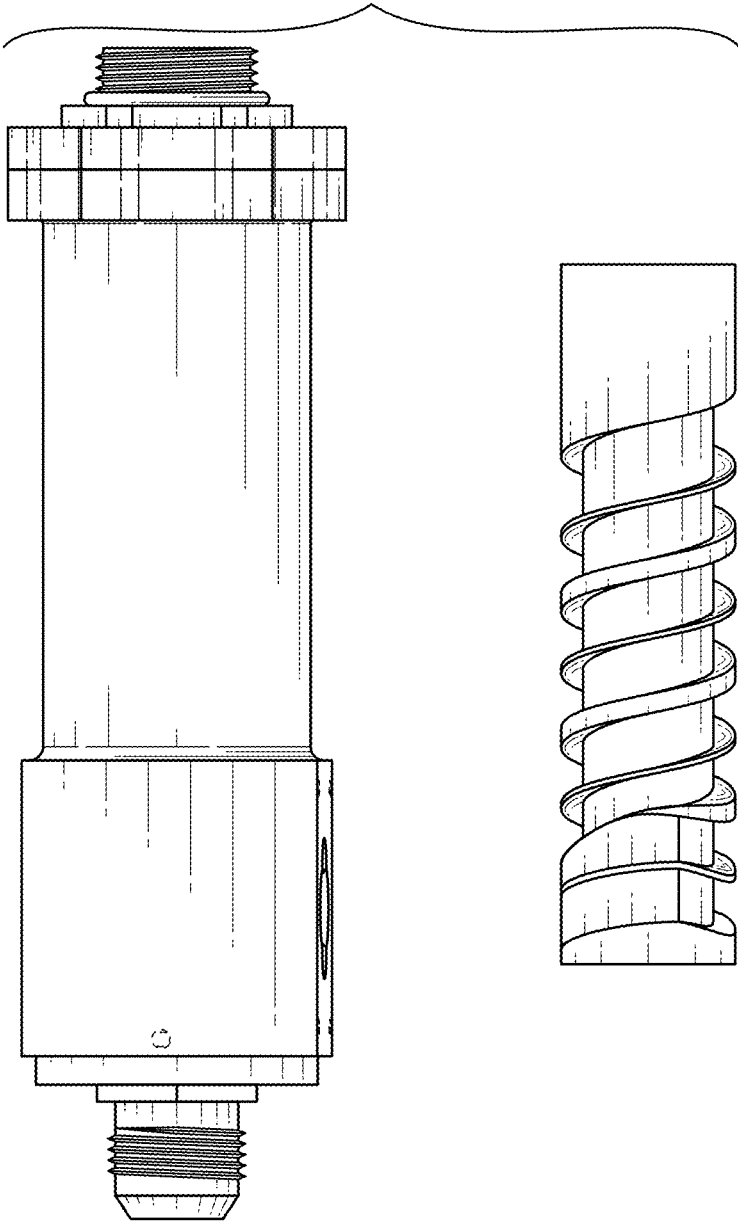

FIG. 8