

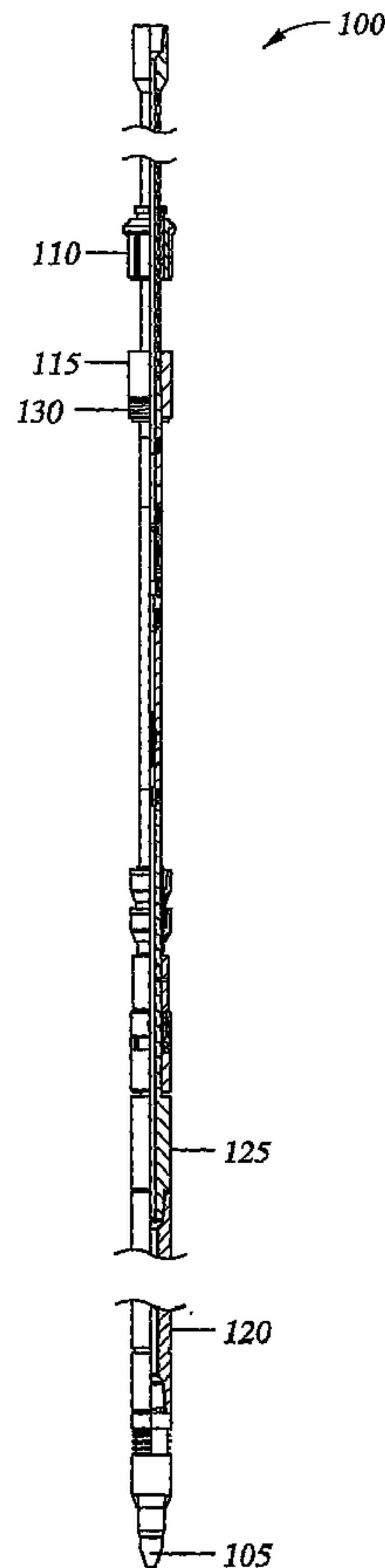

(86) Date de dépôt PCT/PCT Filing Date: 2003/01/23
 (87) Date publication PCT/PCT Publication Date: 2003/08/07
 (45) Date de délivrance/Issue Date: 2009/11/24
 (85) Entrée phase nationale/National Entry: 2004/07/26
 (86) N° demande PCT/PCT Application No.: GB 2003/000288
 (87) N° publication PCT/PCT Publication No.: 2003/064814
 (30) Priorité/Priority: 2002/01/29 (US10/060,029)

(51) Cl.Int./Int.Cl. *E21B 43/10* (2006.01),
E21B 23/01 (2006.01), *E21B 34/14* (2006.01),
E21B 43/08 (2006.01)
 (72) Inventeurs/Inventors:
 SIBLEY, LARRY D., US;
 MAULDIN, DORAN B., US
 (73) Propriétaire/Owner:
 WEATHERFORD/LAMB, INC., US
 (74) Agent: MARKS & CLERK

(54) Titre : APPAREIL D'EXTENSION A UTILISER DANS UN Puits DE FORAGE
 (54) Title: EXPANSION APPARATUS FOR USE IN A WELLBORE



(57) Abrégé/Abstract:

A method and apparatus for setting a liner (200) in a wellbore and then expanding a screen (213) in the wellbore in a single trip are disclosed. A liner and expandable screen is provided with a slip assembly (210) to fix the liner in the wellbore. An expansion tool (105) and work string is run into the wellbore in the liner. After the liner is set, the expansion tool is used to expand the screen. In an

(57) **Abrégé(suite)/Abstract(continued):**

embodiment, an annular area (360) between the expansion tool and work string is utilized in order to set the slips (238). Thereafter, cup packers used in forming the annulus are lifted from the liner prior to expanding the screen.

(12) INTERNATIONAL APPLICATION PUBLISHED UNDER THE PATENT COOPERATION TREATY (PCT)

(19) World Intellectual Property Organization
International Bureau(43) International Publication Date
7 August 2003 (07.08.2003)

PCT

(10) International Publication Number
WO 03/064814 A1

- (51) International Patent Classification⁷: E21B 43/10, 23/01, 34/14, 43/08
- (71) Applicant (for IS only): **HARDING, Richard, Patrick** [GB/GB]; Marks & Clerk, 4220 Nash Court, Oxford Business Park South, Oxford, Oxfordshire OX4 2RU (GB).
- (21) International Application Number: PCT/GB03/00288
- (72) Inventors; and
- (75) Inventors/Applicants (for US only): **SIBLEY, Larry, D.** [US/US]; 4300 Sandy Lane, Slidell, LA 70460 (US). **MAULDIN, Doran, B.** [US/US]; 105 Indiana Avenue, Slidell, LA 70458 (US).
- (22) International Filing Date: 23 January 2003 (23.01.2003)
- (25) Filing Language: English
- (26) Publication Language: English
- (74) Agents: **MARKS & CLERK** et al.; 4220 Nash Court, Oxford Business Park South, Oxford, Oxfordshire OX4 2RU (GB).
- (30) Priority Data:
10/060,029 29 January 2002 (29.01.2002) US
- (81) Designated States (national): AE, AG, AL, AM, AT, AU, AZ, BA, BB, BG, BR, BY, BZ, CA, CH, CN, CO, CR, CU, CZ, DE, DK, DM, DZ, EC, EE, ES, FI, GB, GD, GE, GH, GM, HR, HU, ID, IL, IN, IS, JP, KE, KG, KP, KR, KZ, LC, LK, LR, LS, LT, LU, LV, MA, MD, MG, MK, MN, MW,
- (71) Applicant (for all designated States except US): **WEATHERFORD/LAMB, INC.** [US/US]; 515 Post Oak Blvd, Suite 600, Houston, TX 77027 (US).

[Continued on next page]

(54) Title: EXPANSION APPARATUS FOR USE IN A WELLBORE

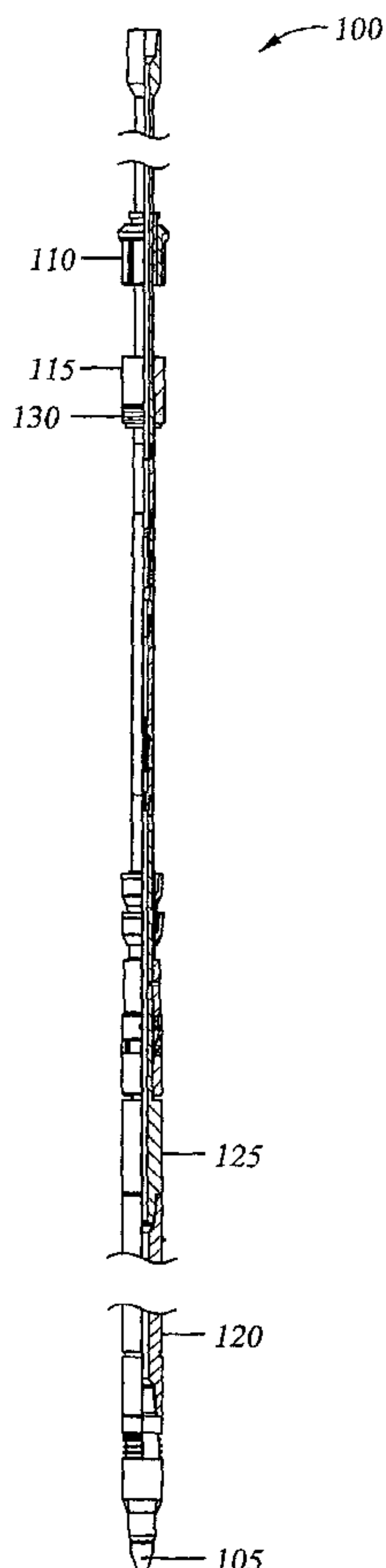

(57) Abstract: A method and apparatus for setting a liner (200) in a wellbore and then expanding a screen (213) in the wellbore in a single trip are disclosed. A liner and expandable screen is provided with a slip assembly (210) to fix the liner in the wellbore. An expansion tool (105) and work string is run into the wellbore in the liner. After the liner is set, the expansion tool is used to expand the screen. In an embodiment, an annular area (360) between the expansion tool and work string is utilized in order to set the slips (238). Thereafter, cup packers used in forming the annulus are lifted from the liner prior to expanding the screen.

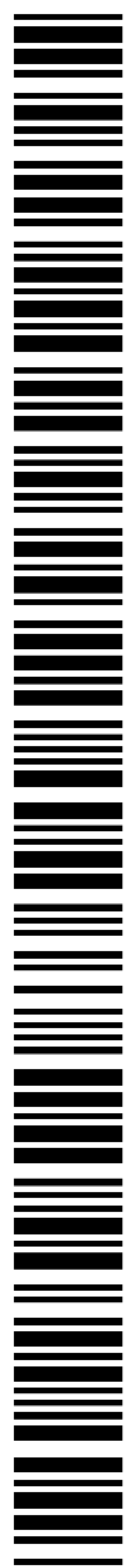

WO 03/064814 A1

WO 03/064814 A1

MX, MZ, NO, NZ, OM, PH, PL, PT, RO, RU, SC, SD, SE, SG, SK, SL, TJ, TM, TN, TR, TT, TZ, UA, UG, US, UZ, VC, VN, YU, ZA, ZM, ZW.

(84) Designated States (regional): ARIPO patent (GH, GM, KE, LS, MW, MZ, SD, SL, SZ, TZ, UG, ZM, ZW), Eurasian patent (AM, AZ, BY, KG, KZ, MD, RU, TJ, TM), European patent (AT, BE, BG, CH, CY, CZ, DE, DK, EE, ES, FI, FR, GB, GR, HU, IE, IT, LU, MC, NL, PT, SE, SI, SK, TR), OAPI patent (BF, BJ, CF, CG, CI, CM, GA, GN, GQ, GW, ML, MR, NE, SN, TD, TG).

Published:

- *with international search report*
- *before the expiration of the time limit for amending the claims and to be republished in the event of receipt of amendments*

For two-letter codes and other abbreviations, refer to the "Guidance Notes on Codes and Abbreviations" appearing at the beginning of each regular issue of the PCT Gazette.

EXPANSION APPARATUS FOR USE IN A WELLBORE

The present invention relates to an apparatus and method using expandable tubulars to complete a well. The invention finds particular application in the installation of an expandable sand screen.

Hydrocarbon wells are typically formed with a central wellbore that is supported by steel casing. The casing lines a borehole formed in the earth during the drilling process. An annular area formed between the casing and the borehole is filled with cement to further support and form the wellbore.

Some wells are produced by perforating the casing of the wellbore at selected depths where hydrocarbons are found. Hydrocarbons migrate from the formation through the perforations and into the wellbore where they are usually collected in a separate string of production tubing for transportation to the surface of the well. In other instances, a lower portion of a wellbore is left open and not lined with casing. This "open hole" completion permits hydrocarbons in an adjacent formation to migrate directly into the wellbore where they are subsequently raised to the surface, possibly through an artificial lift system.

Open hole completions can provide higher production than cased hole completions and they are frequently utilized in connection with horizontally drilled boreholes. However, open hole completions leave aggregate material, including sand, free to invade the wellbore. Sand entering an open hole wellbore causes instability within the open hole which enhances the risk of complete collapse. Sand production can also result in premature failure of artificial lift and other downhole and surface equipment due to the abrasive nature of sand. In some instances, high velocity sand particles can contact and erode lining and tubing.

Sand can also be a problem where casing is perforated to collect hydrocarbons. Typically, casing is perforated with a perforating assembly or "guns" that are run into a wellbore and fired to form the perforations. Thereafter, the assembly is removed and a separate assembly is installed to collect the migrating hydrocarbons. The perforations

also create a passageway for aggregate material, including sand to enter the wellbore. As with an open wellbore, sand entering the cased wellbore can interfere with the operation of downhole tools, clog screens and damage components, especially if the material enters the wellbore at a high velocity.

To control particle flow into a wellbore, well screens are often employed downhole. Conventional wellscreens are placed adjacent perforations or unlined portions of the wellbore to filter out particulates as production fluid enters a tubing string. One form of well screen recently developed is the expandable sand screen (ESS). In general, the ESS is constructed of different composite layers, including a filter media.

A more particular description of an ESS is found in U.S. Patent No. 5,901,789. That patent describes an ESS which consists of a perforated base pipe, a woven filtering material, and a protective, perforated outer shroud. Both the base pipe and the outer shroud are expandable, and the woven filter is typically arranged over the base pipe in sheets that partially cover one another and slide across one another as the sand screen is expanded. The ESS is expanded by a cone-shaped object urged along its inner bore or by an expander tool having radially outward extending rollers that are fluid powered from a tubular string. Using expansion means like these, the ESS is subjected to outwardly radial forces that urge the expanding walls against the open formation or parent casing. The components of the ESS are expanded past their elastic limit, thereby increasing the inner and outer diameter of the tubular.

A major advantage to the ESS in an open wellbore is that once expanded, the walls of the wellbore are supported by the ESS. Additionally, the annular area between the screen and the wellbore is mostly eliminated, and with it the need for a gravel pack. A gravel pack is used with conventional well screens to fill an annular area between the screen and wellbore and to support the walls of the open hole. With an ESS, the screen is expanded to a point where its outer wall places a stress on the walls of the wellbore, thereby providing support to the walls of the wellbore to prevent dislocation of particles. Solid expandable tubulars are oftentimes used in conjunction with an ESS to

provide a zonal isolation capability. In addition to open wellbores, the ESS is effectually used with a perforated casing to control the introduction of particulate matter into the cased wellbore via the perforations.

While an ESS can reduce or eliminate the inflow of particles into a wellbore, the screen must be installed and expanded in order to operate effectively. The present inventors have appreciated that any delay in the installation permits additional time for sand to enter the wellbore and the time period is especially critical between the formation of perforations in a casing wall and the expansion of screen against the perforations. The delays are especially critical if the newly formed wellbore is placed in an over balanced condition prior to expanding the ESS. An overbalanced condition permits fluids to enter the formations and hamper later production of hydrocarbons.

In current installation procedures of ESS the operator makes two trips downhole. In the first trip, the operator sets a liner hanger to secure the ESS in the wellbore. After returning from the first trip downhole, the operator must make a second trip with an expansion tool in order to expand the ESS.

The present inventors have devised a single trip installation process to set a liner hanger in a wellbore and then expand a sand screen.

There are several disadvantages to a multiple trip installation procedure. The biggest disadvantage relates to expensive downtime necessary to make both trips. Also, a delay between the first and second trips can cause well control problems due to fluid loss. For example, pressurized fluid in the wellbore used to actuate various mechanical components during the installation process can enter the formations causing formations to clog-up or collapse, restricting the flow of hydrocarbons. In addition, loss of drilling fluid increases the completion cost of the well. In other instances, a delay between perforating a casing and expanding a sand screen against the perforations increases the likelihood that solids from the formations will enter the wellbore. In addition to the foregoing, packers used to fix an ESS in a wellbore often have a relatively small inside diameter. These packer-like components remain in the wellbore and can cause access problems for remedial work required below the suspension device.

The present invention aims to reduce the time needed to install an expandable sand screen in a wellbore. It further aims to set a sand screen in a wellbore and then expand the sand screen in a single trip. It further aims to provide a method and apparatus to facilitate the setting of a liner hanger in a wellbore prior to the expansion of an ESS. It further aims to minimize the exposure to formation solids before expansion of the ESS. It further aims to provide a single trip ESS apparatus that uses a liner hanger that does not restrict access within the wellbore after the ESS is expanded.

According to an aspect of the present invention there is provided a method of expanding a tubular in a wellbore, comprising:

running an apparatus into the wellbore, the apparatus including:

the tubular for expansion;

fixing means for fixing the tubular in the wellbore;

an expander tool on a work string;

an attachment means between the work string and the tubular;

setting means for setting the fixing means;

the method further comprising:

setting the fixing means in the wellbore so as to fix the tubular in the wellbore;

disengaging the attachment means;

lifting the work string and expansion tool with respect to the tubular;

actuating the expander tool; and

expanding at least a portion of the tubular by means of the expansion tool.

According to another aspect of the present invention there is provided an apparatus for installing an expandable screen in a wellbore, the apparatus comprising:

an outer portion, the outer portion comprising:

a tubular liner and a tubular screen, the screen being expandable by means of an outward radial force applied to its inner surface; and

a slip, the slip being energizable in the wellbore to axially and radially fix the outer portion to the wellbore;

an inner portion coaxially disposed in the outer portion, the inner portion including:

4a

a work string extending between a surface of the well and the apparatus;
an expansion tool disposed at the end of the work string;
an attachment member for temporarily connecting the inner portion to the outer portion; and
sealing members disposed around the inner portion to seal an annulus formed between the inner and outer portion.

According to a further aspect of the present invention there is provided a method of expanding a tubular in a wellbore, comprising:

positioning an apparatus in the wellbore, the apparatus having an expandable tubular and an expansion tool on a work string disposed therein;
setting a slip disposed on the tubular, thereby securing the tubular in the wellbore;
disengaging an attachment means between the work string and the tubular;
lifting the work string and expansion tool with respect to the tubular, whereby a plurality of sealing members disposed on the work string are removed from an annulus defined between the work string and the tubular; and
expanding at least a portion of the tubular through axial movement of the expansion tool and the work string relative to the tubular.

According to an aspect of the present invention there is provided a method of expanding a tubular in a wellbore, comprising:

running an apparatus into the wellbore, the apparatus including:
the tubular for expansion;
a slip for fixing the tubular in a wellbore;
an expander tool on a work string;
an attachment means between the work string and the tubular;
means for setting the slip including sealing members disposed around the work string and temporarily fixed thereto, to seal an annular area formed between the string and tubular;
setting the slip in the wellbore;
disengaging the attachment means;

4b

lifting the work string and expansion tool with respect to the tubular, whereby the sealing members are removed from the tubular;
actuating the expander tool; and
expanding at least a portion of the tubular through axial motion of the expansion tool and work string.

According to another aspect of the present invention there is provided an apparatus for installing an expandable screen in a wellbore, the apparatus comprising:
an outer portion, the outer portion including:

a tubular liner and a tubular screen, the screen expandable with an outward radial force applied to its inner surface; and

a slip, the slip energizable in the wellbore to axially and radially fix the outer portion to the wellbore, wherein the slip includes at least one discrete element thereon;

an inner portion coaxially disposed in the outer portion, the inner portion including:

a work string extending between a surface of the well and the apparatus;

an expander tool disposed at the end of the work string;

an attachment member for temporarily connecting the inner portion to the outer portion; and

sealing members disposed around the inner portion to seal an annulus formed between the inner and outer portion.

According to a further aspect of the present invention there is provided a method for setting a liner and expanding a screen in a wellbore, comprising:

opening a fluid path from an interior of a first tubular to an annular area between the first tubular and an outer tubular;

setting a slip assembly with fluid via the fluid path to secure the outer tubular to the wellbore;

closing the fluid path; and

expanding the screen.

4c

According to a further aspect of the present invention there is provided a method for setting a liner and expanding a screen in a wellbore, comprising:

opening a fluid path from the interior of a first tubular to an annular area between the first tubular and an outer tubular;

setting a slip assembly with fluid via the fluid path;

closing the fluid path; and

expanding the screen with an expander tool having at least one radially extendable member mounted thereupon.

There is disclosed herein a method and apparatus for installing and expanding an ESS in a wellbore in a single trip. In an embodiment of the invention, a liner hanger and expandable screen are provided and are run into the wellbore with an expansion tool and work string. After the hanger is set, the expansion tool is used to expand the screen. In another embodiment, an annular area within the apparatus is utilized in order to set the hanger with pressurized fluid. Thereafter, cup packers used in sealing the annulus are lifted from the liner prior to expanding the screen. The expansion tool and work string are then removed leaving the expanded ESS and hanger in the wellbore.

Some preferred embodiments of the invention will now be described by way of example only and with reference to the accompanying drawings, in which:

Figure 1 is a partial cross section view of an expansion tool assembly.

Figure 2 is a partial cross section view of a liner and sand screen assembly.

Figure 3A illustrates an upper portion of the expansion tool assembly and liner assembly.

Figure 3B illustrates a middle portion of the expansion tool assembly and liner assembly.

Figure 3C illustrates a lower portion of the expansion tool assembly and liner assembly.

Figure 4 illustrates an annular area formed between the expansion tool assembly and liner assembly.

Figure 5 illustrates the expansion tool assembly and liner assembly after a first ball has been dropped into a lower ball seat and sleeve.

Figure 6 illustrates the expansion tool assembly and liner assembly after slips have been set to fix the liner in the wellbore.

Figure 7 illustrates the lower ball seat and sleeve shifted to a second position relative to the liner assembly to reestablish a fluid pathway through the bore of the tool assembly.

Figure 8 illustrates an upper ball seat and sleeve in a second position relative to the liner assembly.

Figure 9 illustrates an upward movement of the tool assembly in relation to the liner assembly.

Figure 10 illustrates the tool assembly lifted out of the liner assembly permitting dogs to clear the top of the liner assembly.

Figure 11 is an enlarged view of Figure 10, showing the expansion tool assembly suspended by dogs at the upper end of the liner assembly.

Figure 12 illustrates downward movement of the expansion tool assembly in relation to the liner assembly and dogs in order to expand the ESS.

Figure 13 illustrates the rotary expander tool expanding the sand screen.

Figure 14 illustrates the expansion tool assembly as it is removed from the liner assembly after the screen has been expanded.

The present invention provides a method and apparatus to install an ESS in a wellbore and to expand the screen in a single trip. The invention includes a hanger which is used to set the screen in a wellbore before the screen is expanded by an expansion tool in the same trip into the wellbore.

Figure 1 illustrates a partial cross section view of an expansion tool assembly 100 and Figure 2 illustrates a partial cross section view of a liner and sand screen assembly 200. While a portion of liner or non slotted tubular is shown in Figure 1, it will be understood that the invention can be used with a section of liner above an expandable sand screen or with only a section of expandable sand screen. Further, while the Figures illustrate the invention in use with an open, non-cased wellbore, it will be further understood that the methods and apparatus disclosed are equally usable in a cased wellbore with perforations formed therein. Figures 1 and 2 show the tool assembly 100 and the liner assembly 200 separated to illustrate the major components of each assembly. In use, the expansion tool assembly 100 is housed within assembly 200. Figures 3 to 14 will fully describe the interface between the tool assembly 100 and the liner assembly 200. In Figure 1, the expansion tool assembly 100 includes a dust cover 110 at the upper end to seal the end of assembly 200 and to prevent wellbore contaminants from entering the liner. The assembly 100 further includes a carry nut 115 with male threads 130 that mates with female threads 205 near the top of the liner assembly 200 to secure the tool assembly 100 in the liner assembly 200.

A carrying tool 125 is located at the lower portion of the assembly 100 to facilitate removal of the tool assembly 100 from the liner assembly 200 after expanding a screen 215. A mud motor 120 is located adjacent to a rotary expander tool 105 at the lower end of the tool assembly 100. In operation, fluid is pumped from the surface of the well down a bore of the tool assembly 100 and into the mud motor 120. The mud motor 120 uses the fluid to rotate the rotary expander tool 105, thereby expanding the

screen 215 disposed at the lower end of the liner assembly 200. A hydraulic liner hanger assembly 210 is located at the upper portion of the liner assembly 200 to secure the assembly 200 in a wellbore.

Figure 3A illustrates the upper section of the expansion tool assembly 100 and the liner assembly 200. The dust cover 110 sits on top of the liner assembly 200. The carry nut 115 is shown threaded into the liner assembly 200. An upper ball seat and sleeve 305 is located below the carry nut 115 and is secured to the tool assembly 100 by a first shear pin 310. A first circumferential groove 330 is used in a later step to reestablish a fluid passageway in the bore of the assembly 100. The liner hanger assembly 210 includes a plurality of cones 325 and slips 328 disposed about the circumference of the liner assembly 200. The slips 328 include a tapered surface that mates with a corresponding tapered surface on the cone 325. During the setting of the liner assembly 200 in the wellbore, the cones 325 are used to displace the slips 328 radially outward as an axial force is applied to the slip 328 in direction of the cones 325.

Figure 3B illustrates a middle section of the expansion tool assembly 100 and the liner assembly 200. A lower ball seat and sleeve 385 is located below the slips 328 (not shown) and is secured in the tool assembly 100 by a second pin 380. Below the lower ball seat and sleeve 385 is a second circumferential groove 340 which is used in a later step to reestablish a fluid passageway down the bore of the assembly 100. A plurality of swab cups 390 used to seal an annular area between the tool assembly 100 and the liner assembly 200 are located below the second shear pin 380. Expandable dogs 350, shown in the retracted position, are located below the swab cups 390. The dogs 350 are used to hold a portion of the tool assembly 100 above the top surface of the liner assembly 200 as will be described herein. A third shear pin 375 is located between the swab cups 390 and the dogs 350 to temporarily hold the dogs 350 and cups 390 around the work string. Figure 3C illustrates a lower portion of the tool assembly 100 and the liner assembly 200. As shown, the expander tool 105 on the tool assembly 100 is housed at an upper end of the expandable sand screen 215. The screen 215 includes a funnel shaped opening to facilitate entry into the screen 215 by the expander tool 105.

Figure 4 illustrates an annular area formed between the expansion tool assembly 100 and liner assembly 200. The annulus is created upon insertion of the tool assembly 100 into the liner assembly 200. The annulus is separated into an upper annulus 355, a middle annulus 360 and a lower annulus 365. The carry nut 115 separates the upper annulus 355 from the middle annulus 360. The swab cups 390 separate the middle annulus 360 from the lower annulus 365. The middle annulus 360 serves as a fluid pathway between a first port 315 and a second port 320 which is later used to set the slips 328 that fix the liner 200 in the wellbore.

Figure 5 illustrates the expansion tool assembly 100 and liner assembly 200 after a first ball 345 has been dropped into a lower ball seat and sleeve 385. The view further illustrates, the liner assembly 200 prior to setting the slips 328. As shown, there is no contact between the teeth 335 on the slips 328 and a casing 475. At a later point the tapered portion of the slips 328 will be urged up cones 325 by a plurality of longitudinal members 415 that are connected to an annular piston 395. The piston 395 has a top O-ring 405 and a bottom O-ring 410 for creating a fluid tight seal.

Figure 6 illustrates the expansion tool assembly 100 and liner assembly 200 after the slips 328 have been set to fix the liner 200 in the wellbore. Ball 345 blocks fluid flow through the bore of the tool assembly 100, thereby redirecting the fluid flow to a first aperture 420 formed in the sleeve 305. The first aperture 420 is aligned with the first port 315 formed in a wall of the tool assembly 100 to form a fluid passageway to the annulus 360. A first arrow 425 illustrates the fluid flow into the annulus 360 and a second arrow 430 illustrates fluid flow from the annulus 360 through a second port 320. The fluid exiting the second port 320 acts on the piston 395, thereby urging the piston 395 upward in the direction of the cones 325. The longitudinal members 415 connecting the slips 328 to the piston 395 urges the slips 328 up the tapered portion of the cones 325, thereby expanding the slips 328 radially outward in contact with the casing 475. The teeth 335 formed on the outer surface of the slips 328 "bite" into the casing surface to hold the liner assembly 200 in position in the wellbore. Figure 6 illustrates that the inner diameter of the assembly 200 is largely unobstructed by the set hanger and the bore is open to the passage of tools downhole.

Figure 7 illustrates the lower ball seat and sleeve 385 shifted to a second position relative to the liner assembly 200 to reestablish a fluid pathway through the bore of the tool assembly 100. After the liner assembly 200 is set in the casing 475, the fluid becomes pressurized acting against the first ball 345 which is housed in the lower ball seat and sleeve 385. At a predetermined pressure, pin 380 is sheared allowing the ball seat and sleeve 385 to shift downward to a second position. In the second position, a first by pass port 435 formed in the sleeve 385 aligns with the second circumferential groove 340 to reestablish a fluid pathway through the bore of the tool assembly 100 as illustrated by an arrow 432.

Figure 8 illustrates the upper ball seat and sleeve 305 in a second position relative to the liner assembly 200 to establish a fluid pathway through the bore of the tool assembly 100. The flow path is established in order to provide a source of pressurized fluid to the expander tool 105 in order to expand the sand screen 215 at a lower end of the liner assembly 200. The second ball 440 is dropped into the tool assembly 100 and lands on an upper seat and sleeve 305 which is held in place by pin 310. Fluid thereafter becomes pressurized acting against the second ball 440. At a predetermined pressure the pin 310 is sheared allowing upper ball seat and sleeve 305 to shift downward to the second position. In the second position, the ball seat and sleeve 305 aligns a second bypass port 450 with the first circumferential groove 330 to provide a fluid passage way. The fluid flow down the bore of the assembly 100 bypasses the ball 440 as illustrated by arrow 445. In addition to reestablishing flow down the bore of the tool assembly 100, the seat and sleeve 305 also misaligns the first aperture 420 and the first port 315, thereby blocking fluid communication into middle annulus 360.

Figure 9 illustrates an upper movement of the tool assembly 100 in relation to the liner assembly 200. After the liner assembly 200 has been set in the wellbore, the expansion tool 100 with the carry nut 115 is rotated clockwise, thereby removing the male threads 130 on the carry nut 115 from the female threads 205 on the liner assembly 200. The tool assembly 100 is then lifted axially upward in relation to the liner assembly 200 as illustrated by a directional arrow 460. A shoulder 455 on the tool assembly 100 urges the carry nut 115 upward with the tool assembly 100 as the tool assembly 100 is partially lifted from the liner assembly 200.

Figure 10 illustrates the tool assembly 100 lifted out of the liner assembly 200 permitting dogs 350 to clear the top of the liner assembly 200. To prepare the tool assembly 100 to expand the screen 215, the expansion tool assembly 100 is partially pulled from the liner assembly 200 exposing the dust cover 110, carry nut 115, swab cups 390 and dogs 350. Upon removal from the liner assembly 200, the dogs 350 expand outward. Pin 375 holds the various components together.

Figure 11 is an enlarged view of Figure 10, showing the expansion tool assembly 100 suspended by dogs 350 at the upper end of the liner assembly 200. After the tool assembly 100 is lifted from the liner assembly 200 and the dogs 350 expanded, it is then lowered until the expanded dogs 350 rest on top of the liner assembly 200. As shown, the dogs 350 are outwardly biased members that are constructed and arranged to ride along a tubular surface and then to extend outward when pulled out of contact with the tubular. With the components in position shown in Figure 11, the expander tool 105 is ready to be lowered into the ESS 215.

Figure 12 illustrates downward movement of the expansion tool assembly 100 in relation to the liner assembly 200 and dogs 350 in order to expand the expandable sand screen 215. A downward force is placed the tool assembly 100, thereby exerting pressure on the pin 375. At a predetermined pressure, the pin 375 is sheared, thereby allowing the mud motor 120 and expander tool 105 along with the carrying tool 125 to drop down into the liner assembly 200 while the dust cover 110, the carry nut 115, the swab cups 390 and the dogs 350 remain above the top of the liner assembly 200. The tool assembly 100 is lowered until the expander tool 105 comes in contact with the ESS 215.

Figure 13 illustrates the rotary expander tool 105 expanding the sand screen 215. Fluid is pumped from the surface of the well down the bore of tool assembly 100 into the mud motor 120. The mud motor 120 provides rotational force to the expander tool 105 while causing radially extending rollers to extend outwards, thereby expanding the sand screen 215 into the borehole. Figure 13 illustrates expanding a sand screen 215 in a vertical open hole. However, this invention is not limited to the one shown but rather

can be used in many different completion scenarios such as casing that has been perforated.

Figure 14 illustrates the expansion tool assembly 100 as it is removed from the liner assembly 200 after the ESS 215 has been expanded. As the tool assembly 100 is pulled upward, a top surface 470 of the carrying tool 125 contacts a bottom surface 465 of the dogs 350, thereby urging the dogs 350 off the top of the liner assembly 200. The entire tool assembly 100 is moved up out of the liner assembly 200 and then out of the wellbore. The ESS 215 allows hydrocarbons to enter the wellbore as it filters out sand and other particles. The expanded sand screen 215 is connected to production tubing at an upper end, thereby allowing the hydrocarbons travel to the surface of the well. In addition to filtering, the sand screen 215 preserves the integrity of the formation during production.

Although the invention has been described in terms of preferred embodiments as set forth above, it should be understood that these embodiments are illustrative only and that the claims are not limited to those embodiments. Those skilled in the art will be able to make modifications and alternatives in view of the disclosure which are contemplated as falling within the scope of the appended claims.

The embodiments of the invention in which an exclusive property or privilege is claimed are defined as follows:

1. A method of expanding a tubular in a wellbore, comprising:
running an apparatus into the wellbore, the apparatus including:
the tubular for expansion;
fixing means for fixing the tubular in the wellbore;
an expander tool on a work string;
an attachment means between the work string and the tubular;
setting means for setting the fixing means;
the method further comprising:
setting the fixing means in the wellbore so as to fix the tubular in the wellbore;
disengaging the attachment means;
lifting the work string and expansion tool with respect to the tubular;
actuating the expander tool; and
expanding at least a portion of the tubular by means of the expansion tool.
2. The method of claim 1, wherein the fixing means comprises a slip.
3. The method of claim 1 or 2, wherein the setting means comprises sealing members disposed around the work string, to seal an annular area formed between the string and the tubular.
4. The method of claim 3, wherein the sealing members are temporarily fixed to the work string.
5. The method of claim 3 or 4, wherein, when the work string and expansion tool are lifted with respect to the tubular, the sealing members are removed from the tubular.
6. The method of any one of claims 1, 2, 4 or 5, wherein said at least a portion of the tubular is expanded through axial motion of the expansion tool and the work string.

7. The method of claim 3, wherein said at least a portion of the tubular is expanded through axial motion of the expansion tool and the work string.
8. The method of any one of claims 1 to 6, whereby lifting the work string and expansion tool includes lifting that portion of the work string and expansion tool including at least one dog member to a location above a top of a liner of the wellbore, thereby suspending the at least one dog at the liner top.
9. The method of claim 7, whereby lifting the work string and expansion tool includes lifting that portion of the work string and expansion tool including at least one dog member to a location above a top of a liner of the wellbore, thereby suspending the at least one dog at the liner top.
10. The method of claim 9, wherein expanding the tubular through an axial motion includes shearing a member for fixing the sealing member and the at least one dog to the work string.
11. The method of any one of claims 1 to 10, whereby the tubular comprises a solid portion and a slotted portion.
12. The method of any one of claims 1 to 11, further comprising removing the expansion tool and the work string from the tubular.
13. An apparatus for installing an expandable screen in a wellbore, the apparatus comprising:
 - an outer portion, the outer portion comprising:
 - a tubular liner and a tubular screen, the screen being expandable by means of an outward radial force applied to its inner surface; and
 - a slip, the slip being energizable in the wellbore to axially and radially fix the outer portion to the wellbore;
 - an inner portion coaxially disposed in the outer portion, the inner portion including:
 - a work string extending between a surface of the well and the apparatus;

an expansion tool disposed at the end of the work string;
an attachment member for temporarily connecting the inner portion to the outer portion; and
sealing members disposed around the inner portion to seal an annulus formed between the inner and outer portion.

14. The method of claim 1, wherein the expansion tool has at least one radially extendable member mounted thereupon.
15. A method of expanding a tubular in a wellbore, comprising:
positioning an apparatus in the wellbore, the apparatus having an expandable tubular and an expansion tool on a work string disposed therein;
setting a slip disposed on the tubular, thereby securing the tubular in the wellbore;
disengaging an attachment means between the work string and the tubular;
lifting the work string and expansion tool with respect to the tubular, whereby a plurality of sealing members disposed on the work string are removed from an annulus defined between the work string and the tubular; and
expanding at least a portion of the tubular through axial movement of the expansion tool and the work string relative to the tubular.
16. A method of expanding a tubular in a wellbore, comprising:
running an apparatus into the wellbore, the apparatus including:
the tubular for expansion;
a slip for fixing the tubular in a wellbore;
an expander tool on a work string;
an attachment means between the work string and the tubular;
means for setting the slip including sealing members disposed around the work string and temporarily fixed thereto, to seal an annular area formed between the string and tubular;
setting the slip in the wellbore;
disengaging the attachment means;
lifting the work string and expansion tool with respect to the tubular, whereby the sealing members are removed from the tubular;

actuating the expander tool; and
expanding at least a portion of the tubular through axial motion of the expansion tool and work string.

17. The method of claim 16, whereby lifting the work string and expansion tool includes lifting that portion of the work string and expansion tool including at least one dog member to a location above a top of the liner, thereby suspending the dogs at the liner top.

18. The method of claim 17, whereby the tubular includes a solid portion and a slotted portion.

19. The method of claim 18, wherein expanding the tubular through an axial motion includes shearing a member for fixing the sealing member and dogs to the work string.

20. The method of claim 16, further includes removing the expander tool and the work string from the tubular.

21. An apparatus for installing an expandable screen in a wellbore, the apparatus comprising:

an outer portion, the outer portion including:

a tubular liner and a tubular screen, the screen expandable with an outward radial force applied to its inner surface; and

a slip, the slip energizable in the wellbore to axially and radially fix the outer portion to the wellbore, wherein the slip includes at least one discrete element thereon;

an inner portion coaxially disposed in the outer portion, the inner portion including:

a work string extending between a surface of the well and the apparatus;

an expander tool disposed at the end of the work string;

an attachment member for temporarily connecting the inner portion to the outer portion; and

sealing members disposed around the inner portion to seal an annulus formed between the inner and outer portion.

22. The apparatus of claim 21, wherein the expander tool includes at least one radially extendable member.
23. A method for setting a liner and expanding a screen in a wellbore, comprising:
opening a fluid path from an interior of a first tubular to an annular area between the first tubular and an outer tubular;
setting a slip assembly with fluid via the fluid path to secure the outer tubular to the wellbore;
closing the fluid path; and
expanding the screen.
24. The method of claim 23, wherein the fluid path is opened by dropping a ball into a ball seat, thereby blocking fluid flow through a bore of the apparatus.
25. The method of claim 24, wherein the fluid pathway is closed by shifting a sleeve to a second position.
26. A method for setting a liner and expanding a screen in a wellbore, comprising:
opening a fluid path from the interior of a first tubular to an annular area between the first tubular and an outer tubular;
setting a slip assembly with fluid via the fluid path;
closing the fluid path; and
expanding the screen with an expander tool having at least one radially extendable member mounted thereupon.

1/15

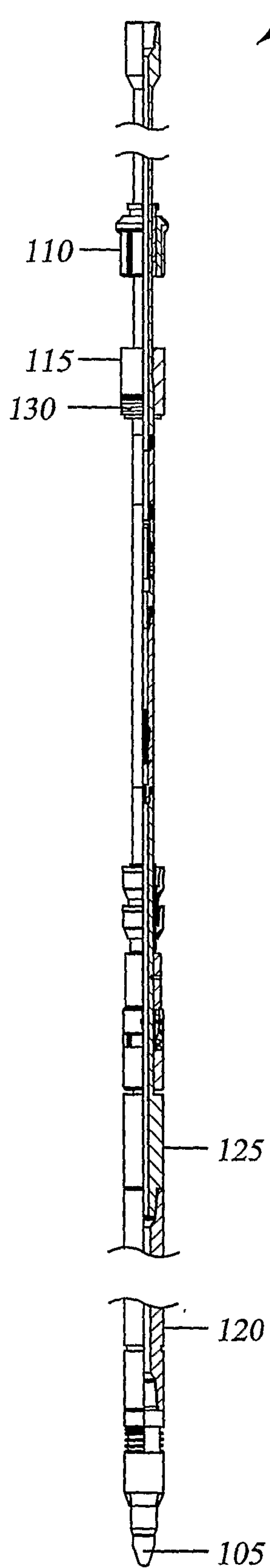

Fig. 1

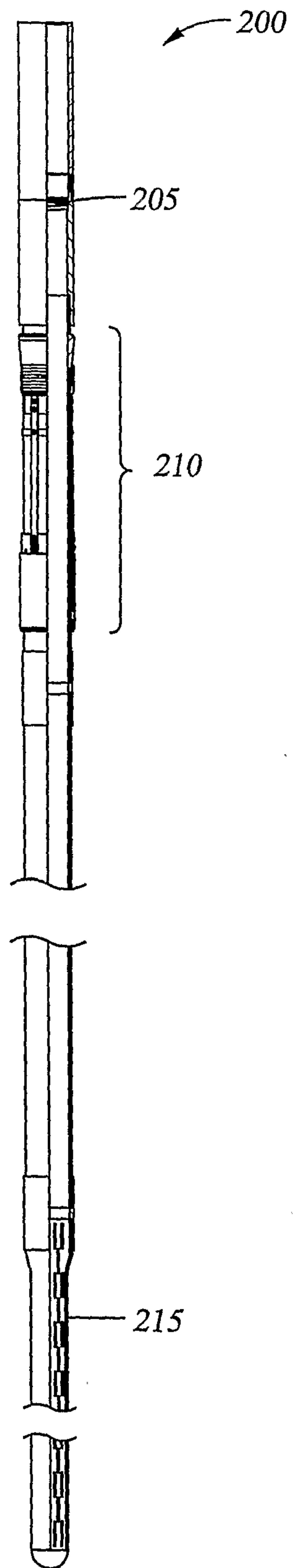

Fig. 2

2/15

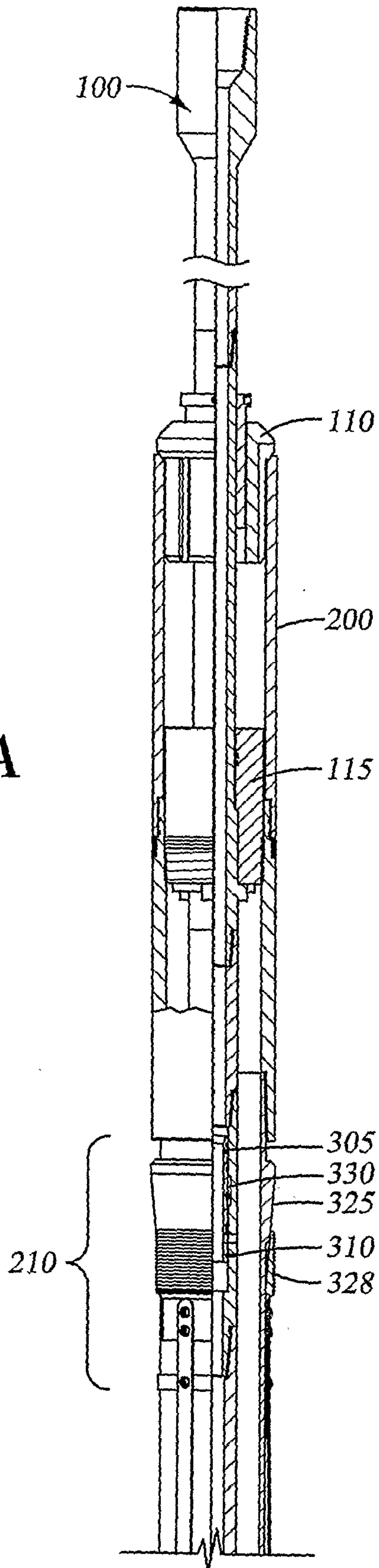

Fig. 3A

3/15

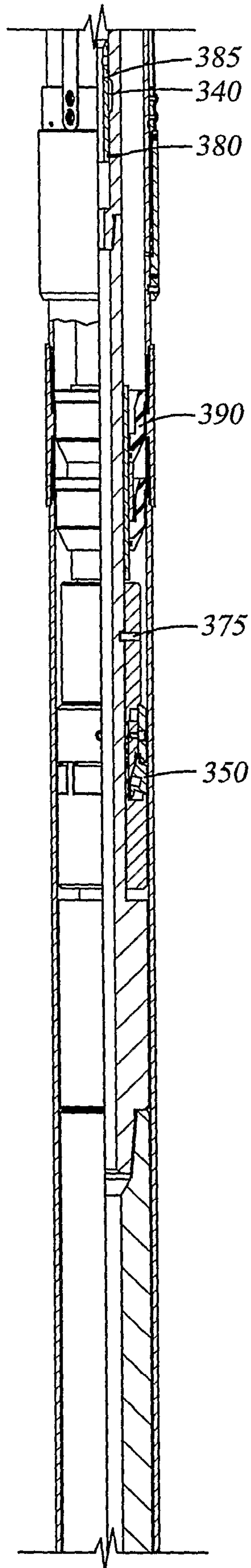

Fig. 3B

4/15

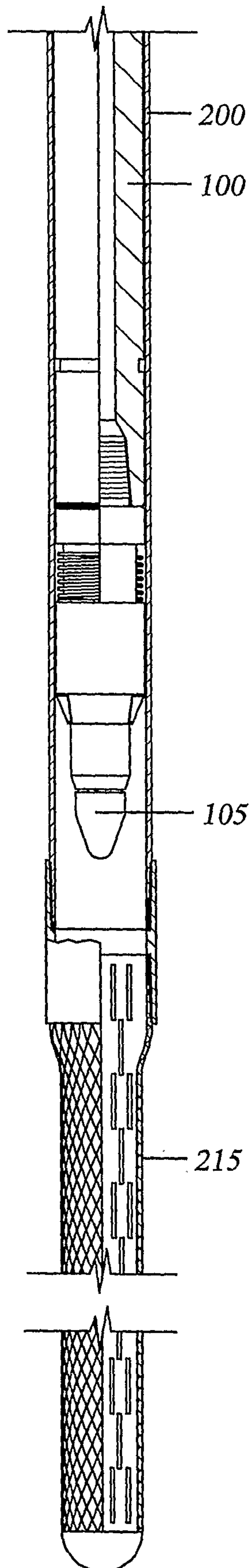

Fig. 3C

5/15

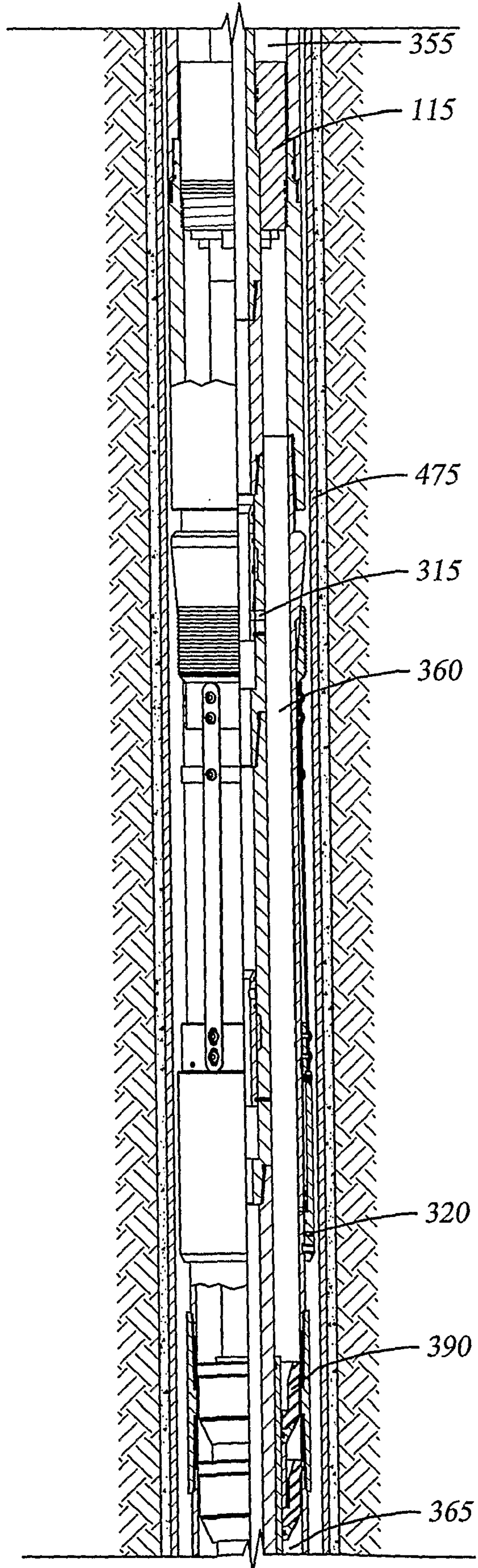

Fig. 4

6/15

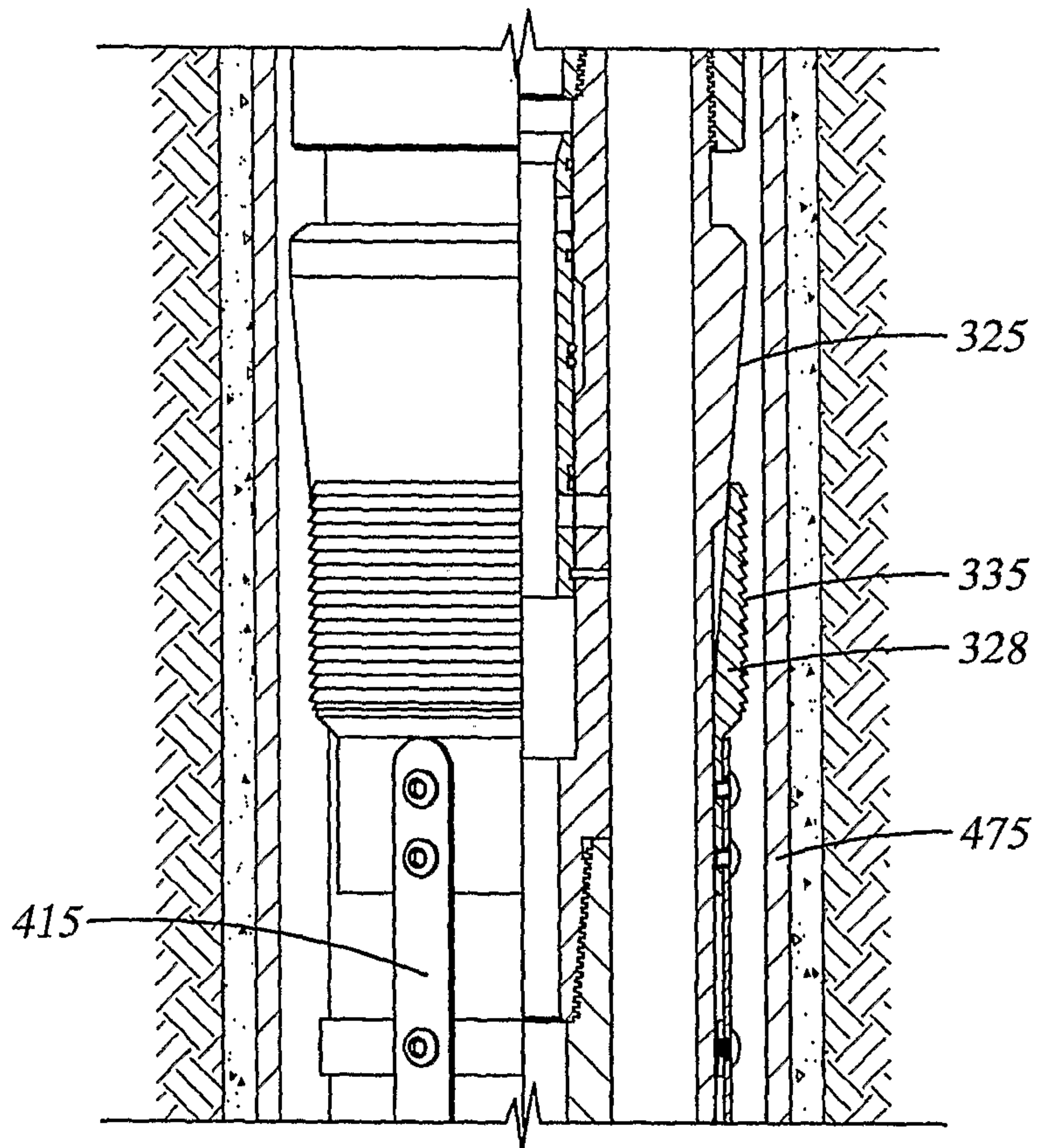
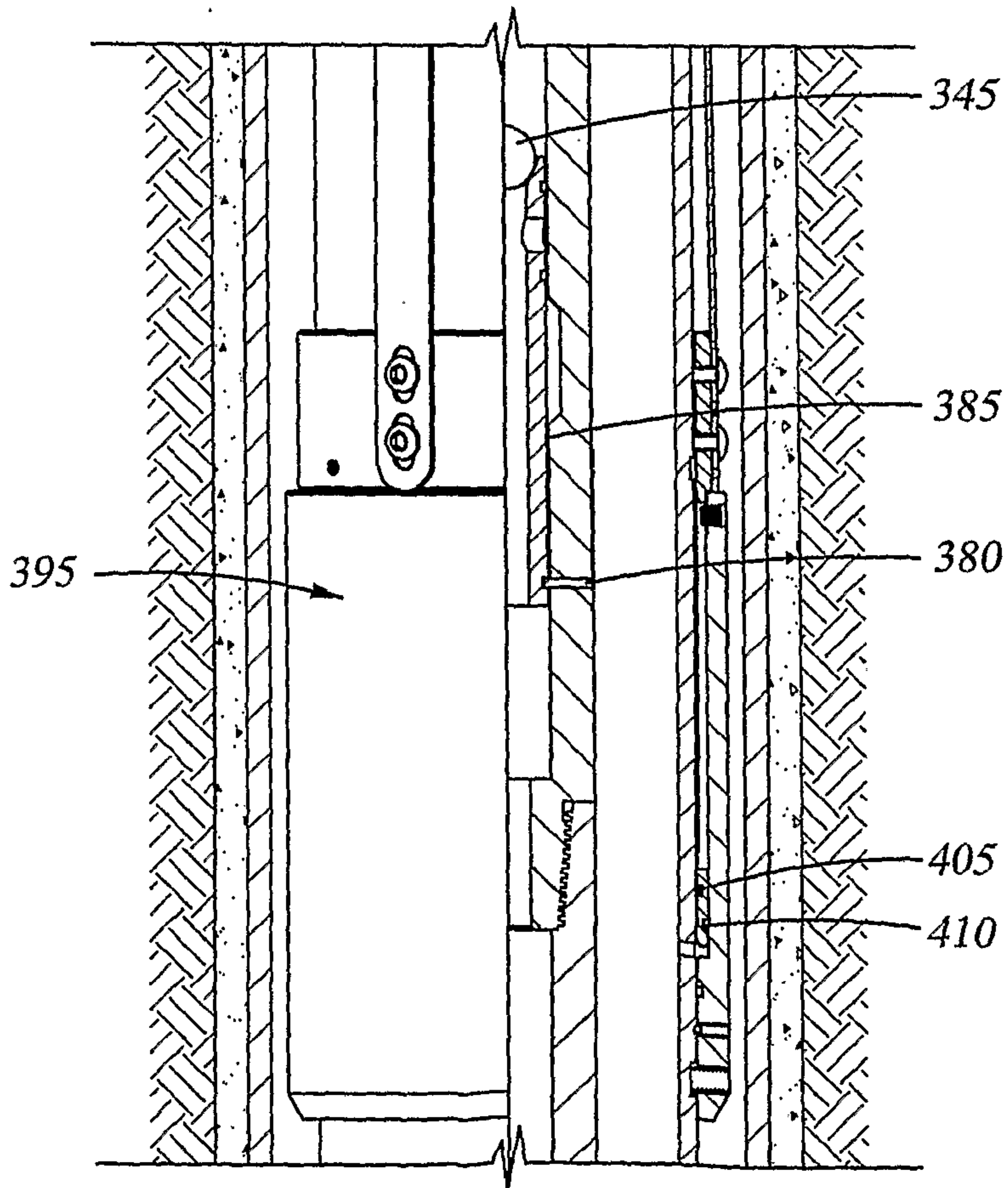

Fig. 5



7/15

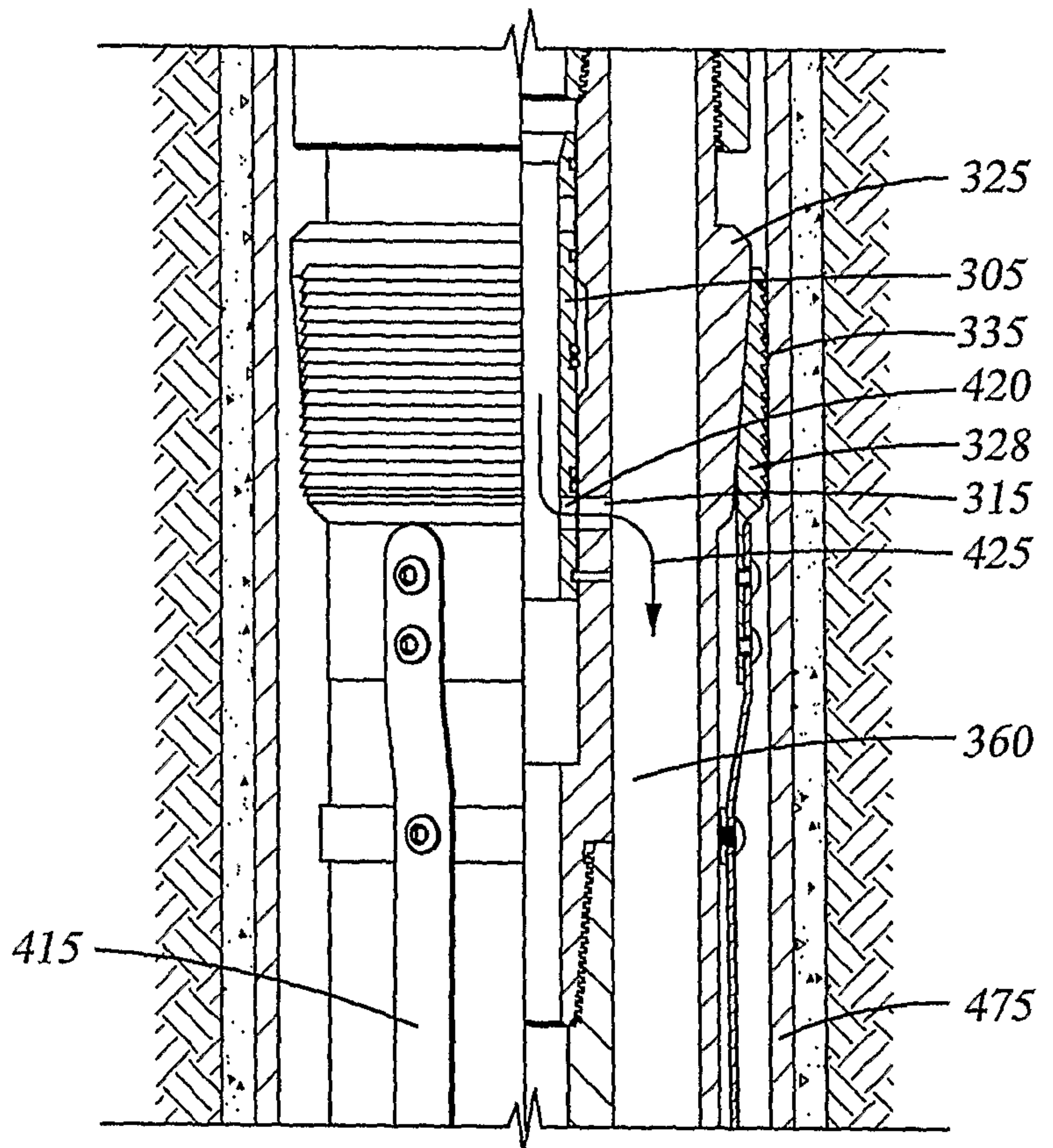
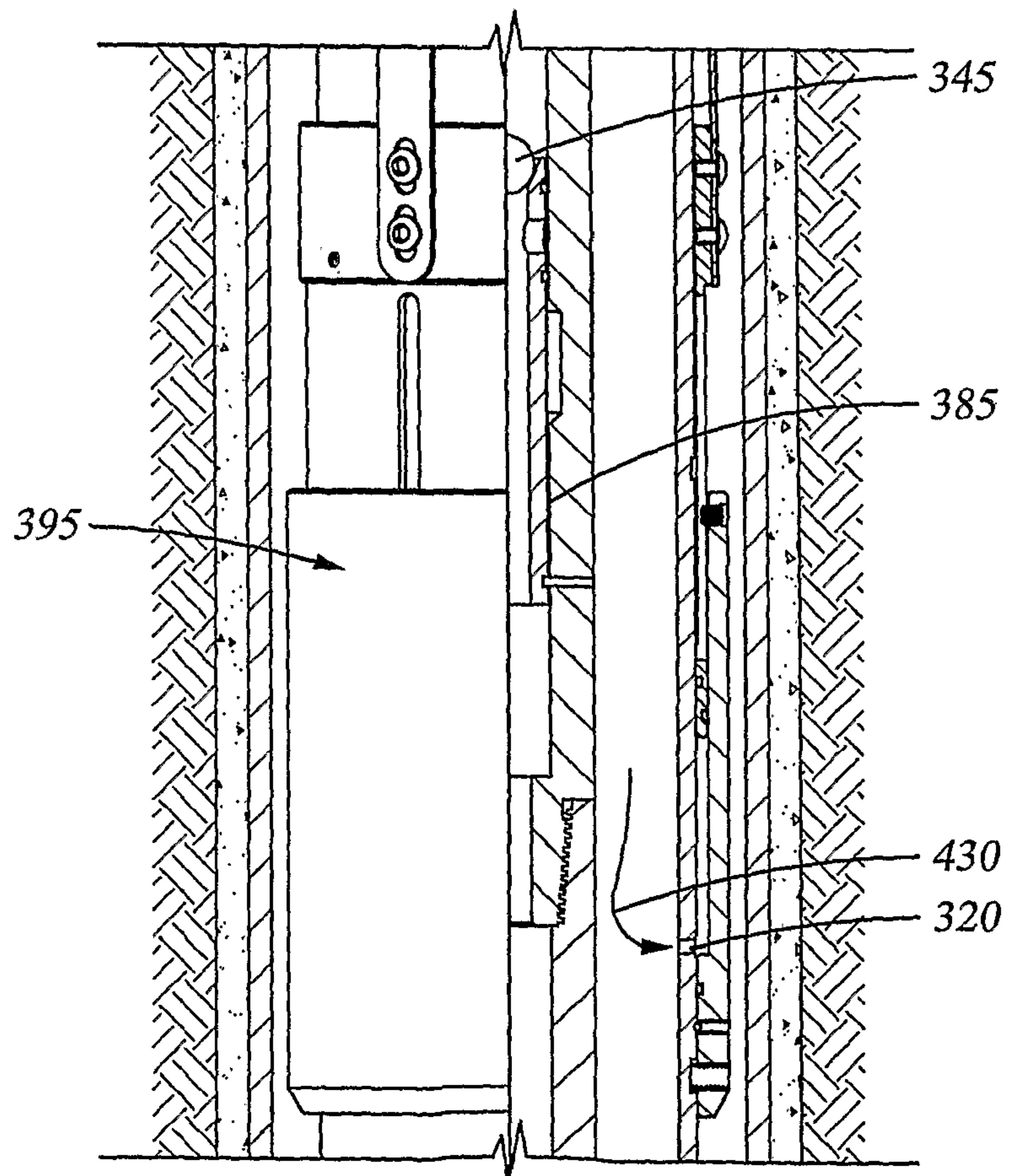

Fig. 6



8/15

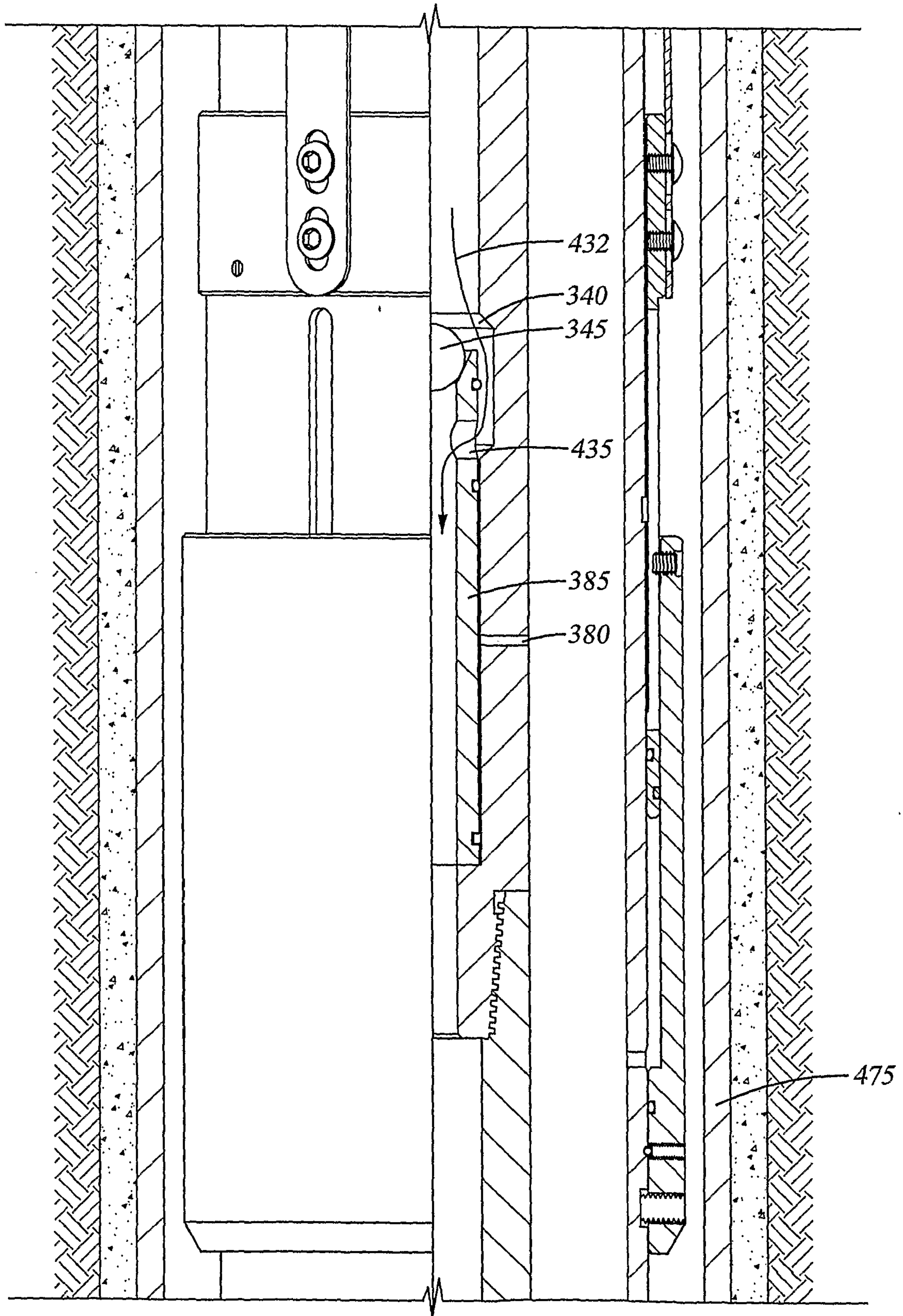

Fig. 7

9/15

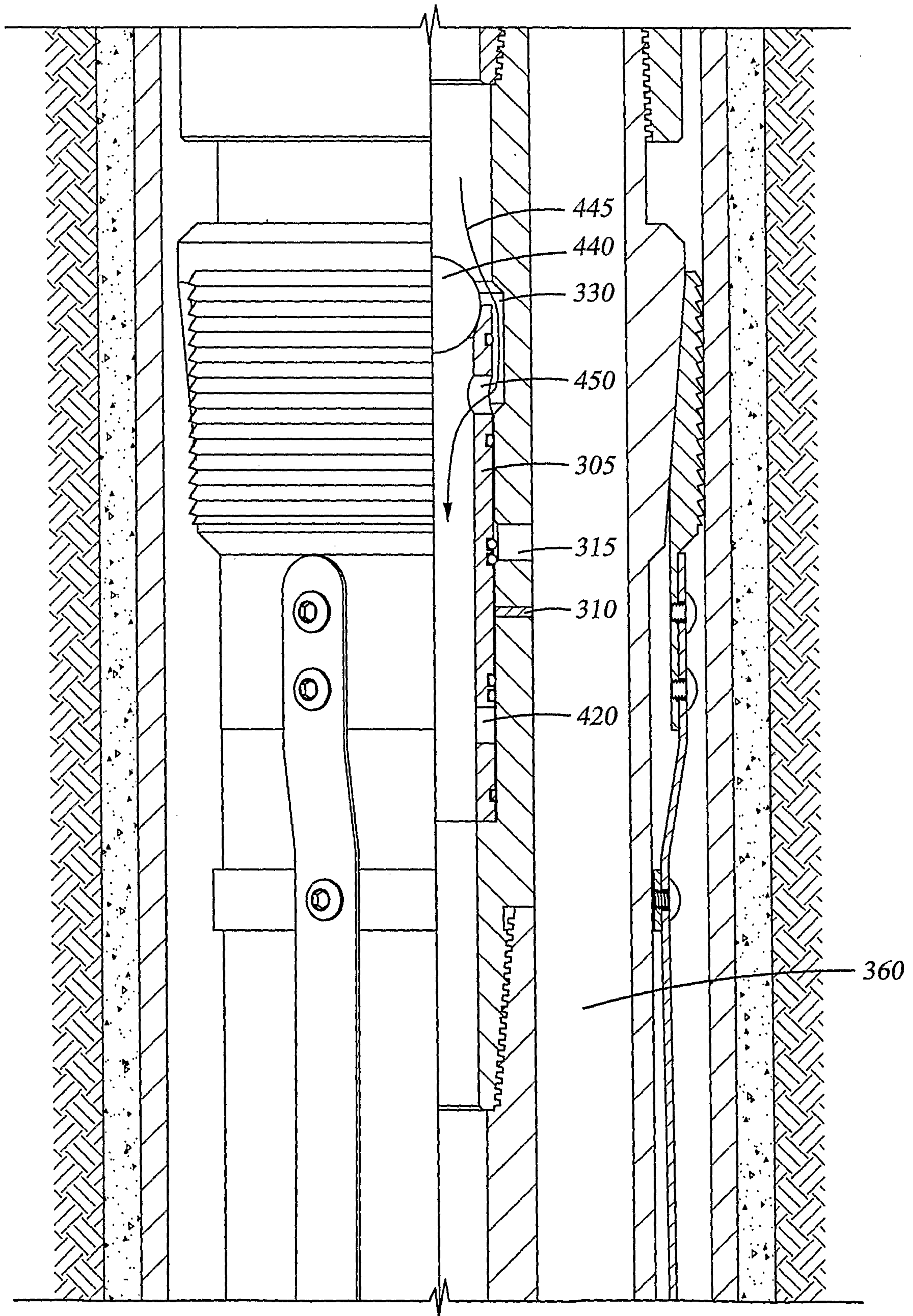

Fig. 8

10/15

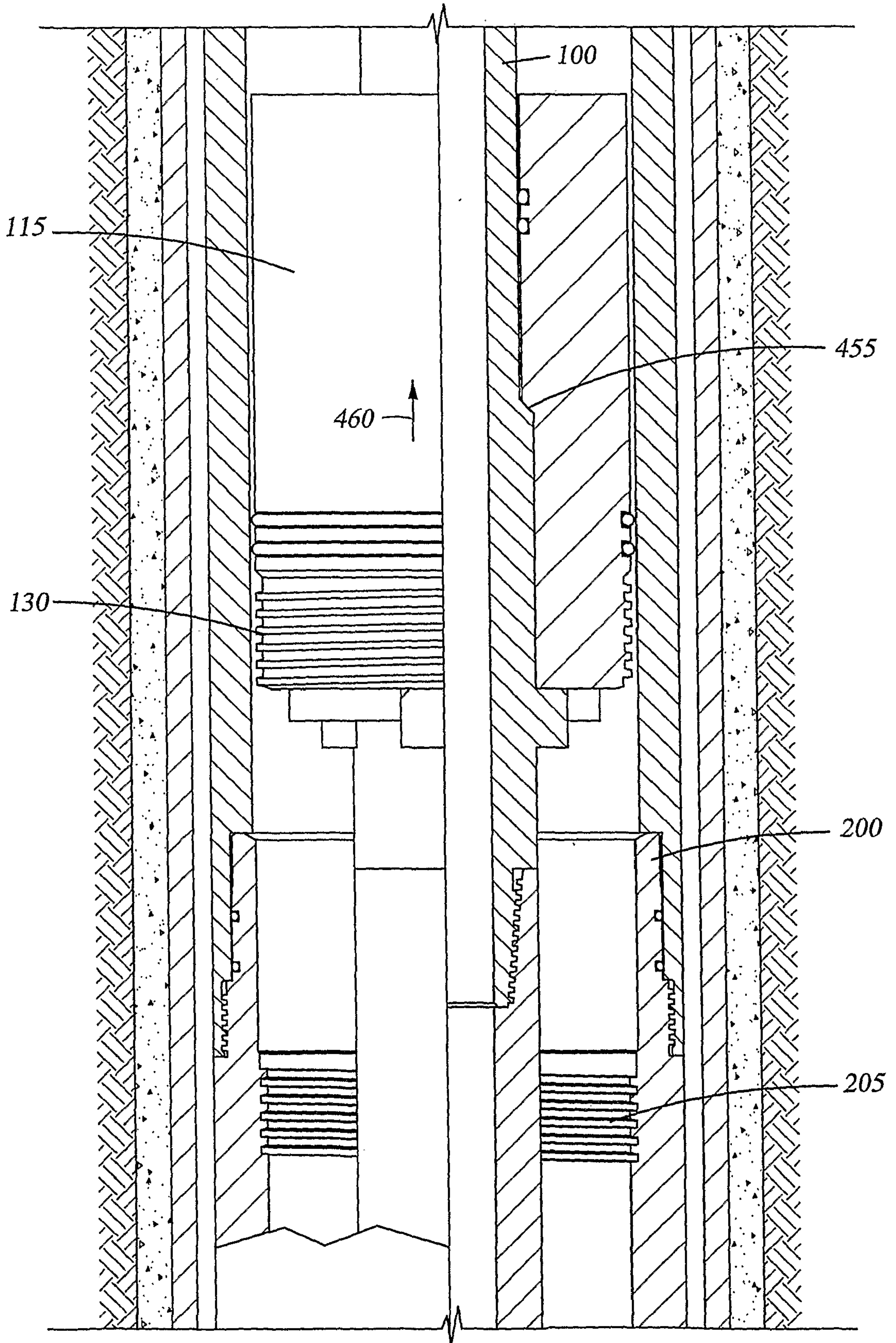

Fig. 9

11/15

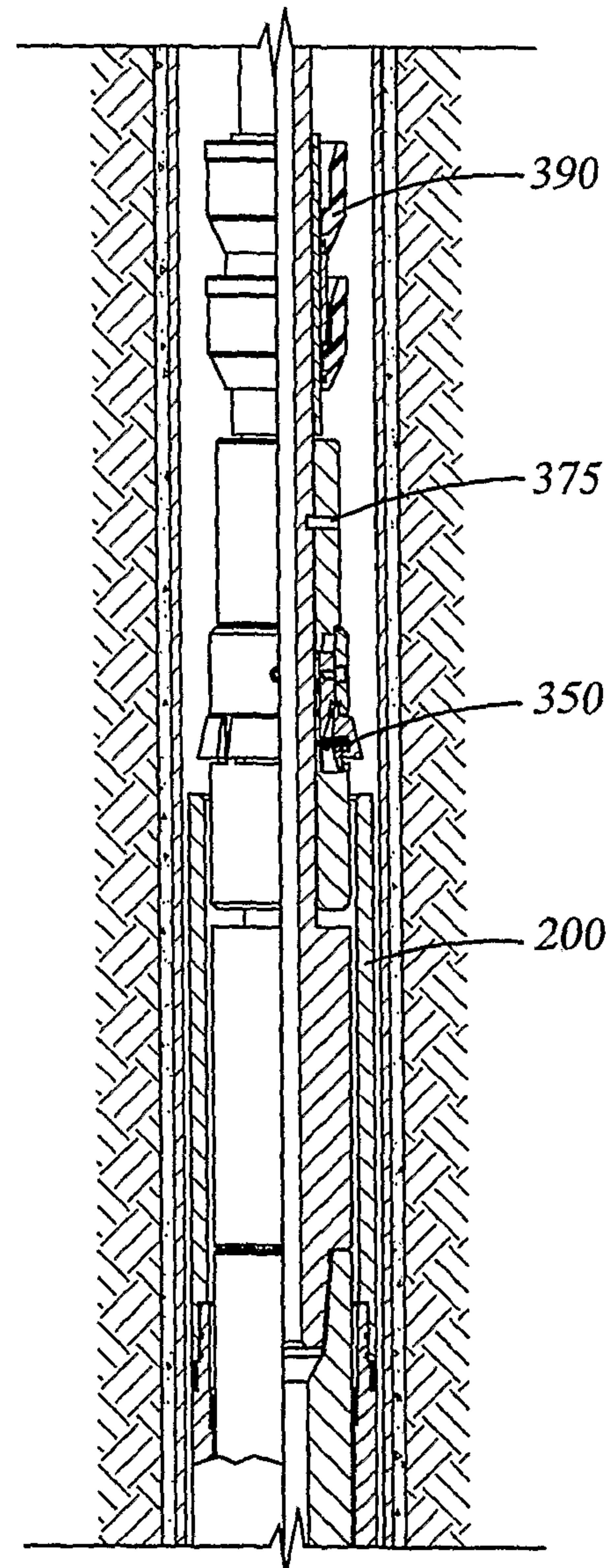
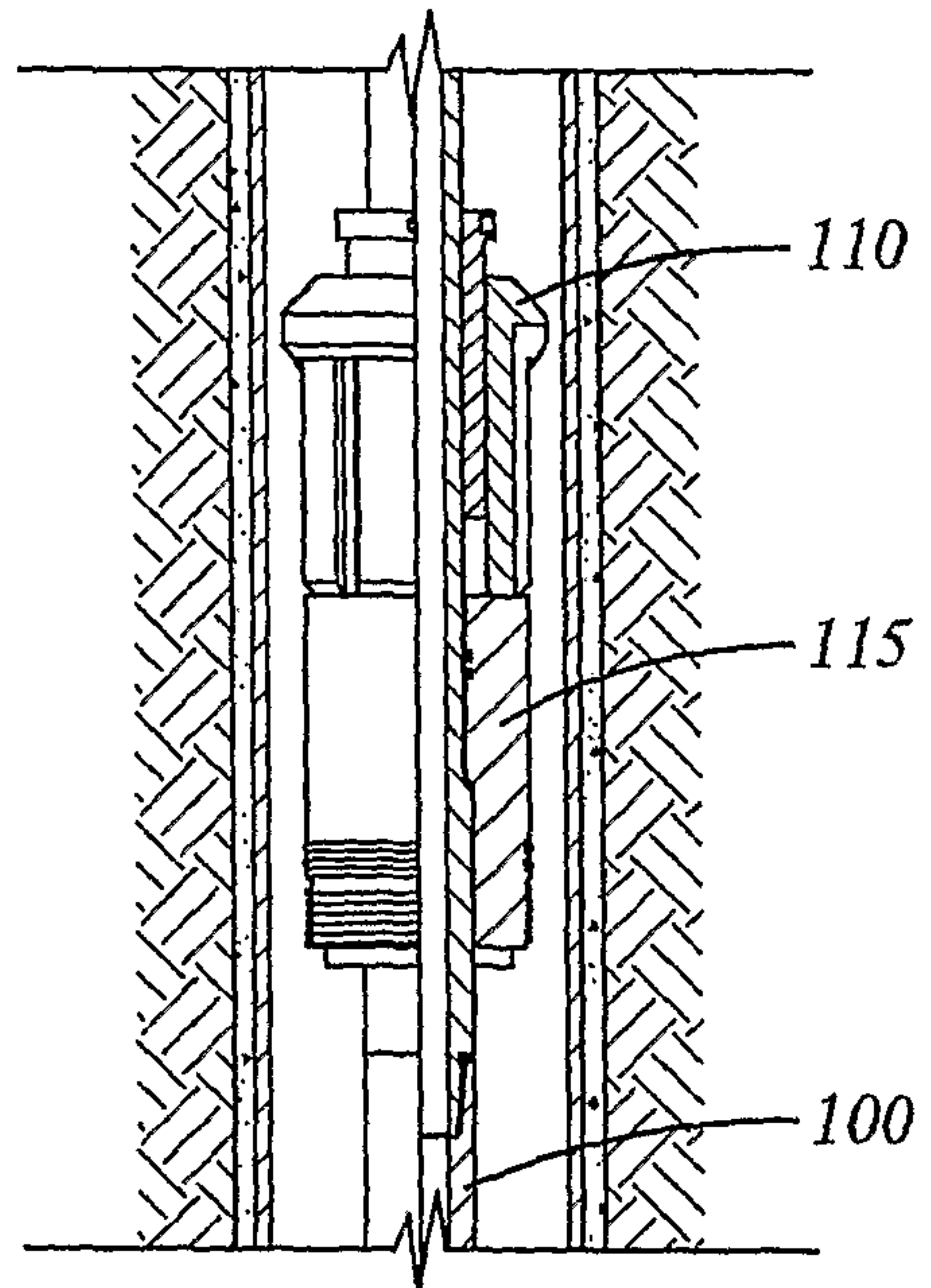
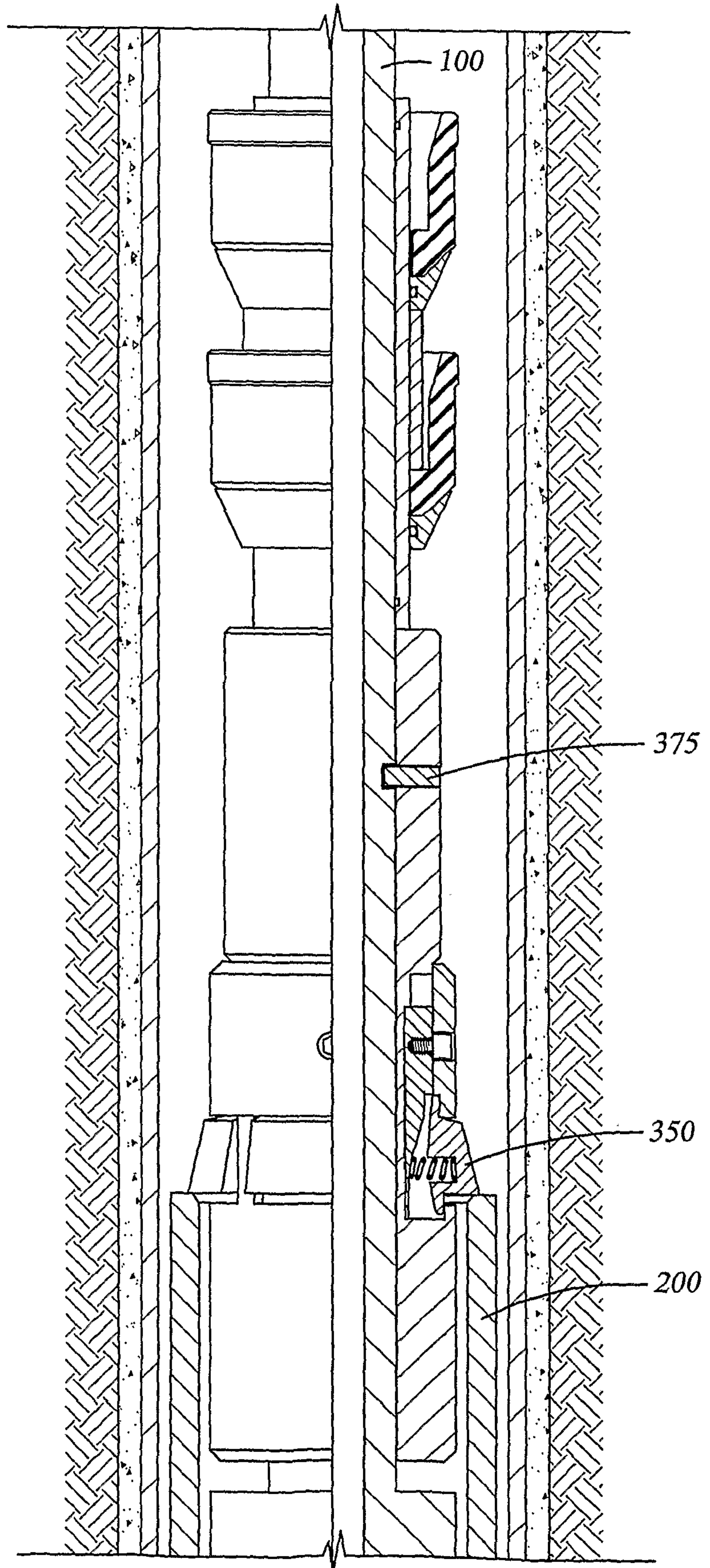

Fig. 10

12/15

Fig. 11



13/15

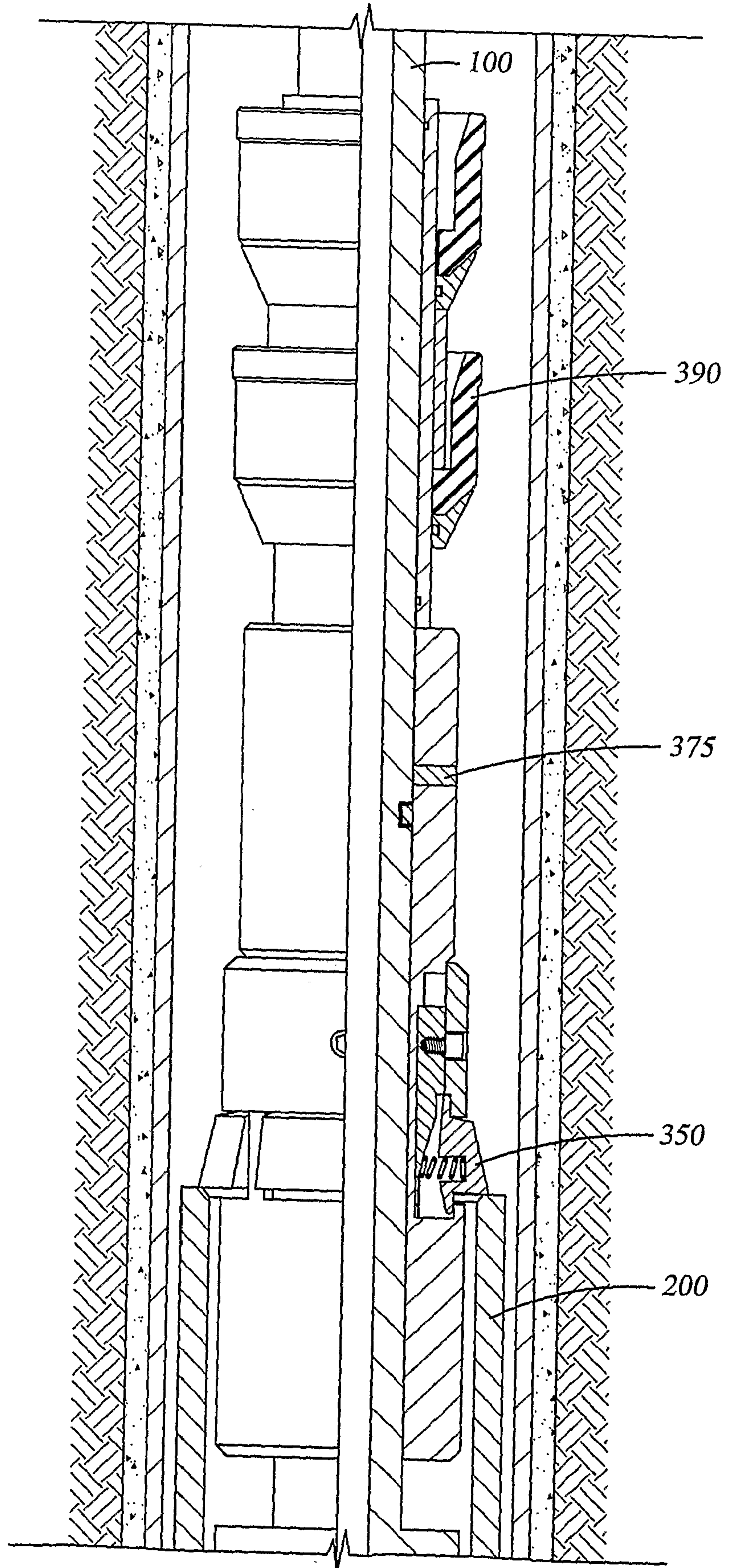

Fig. 12

14/15

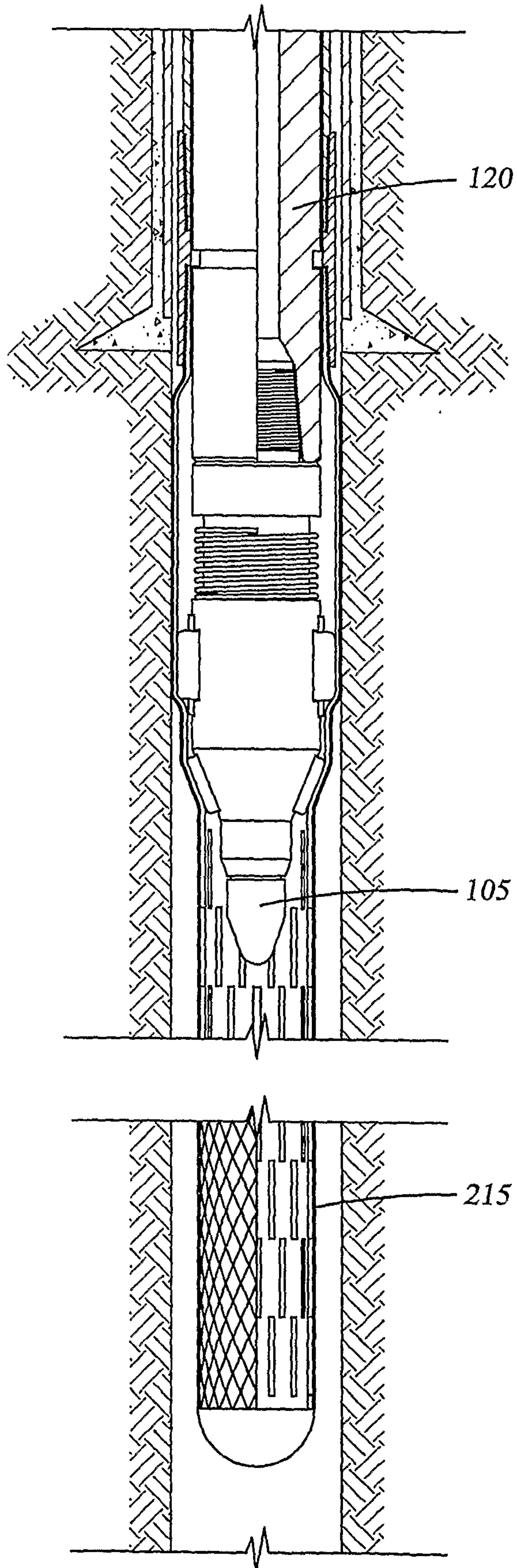

Fig. 13

15/15

Fig. 14

