



(11) **EP 3 576 587 B1**

(12) **EUROPEAN PATENT SPECIFICATION**

(45) Date of publication and mention of the grant of the patent:
25.09.2024 Bulletin 2024/39

(21) Application number: **18747808.6**

(22) Date of filing: **02.02.2018**

(51) International Patent Classification (IPC):

A47K 13/10 ^(2006.01) **A47K 11/04** ^(2006.01)
A47K 13/24 ^(2006.01) **A47K 13/28** ^(2006.01)
A61G 5/14 ^(2006.01) **A61G 7/10** ^(2006.01)
A61G 7/14 ^(2006.01)

(52) Cooperative Patent Classification (CPC):

A61G 5/1002; A47K 11/04; A61G 5/1056;
A61G 2203/34

(86) International application number:

PCT/US2018/016554

(87) International publication number:

WO 2018/144793 (09.08.2018 Gazette 2018/32)

(54) **TOILET**

TOILETTE

TOILETTES

(84) Designated Contracting States:

**AL AT BE BG CH CY CZ DE DK EE ES FI FR GB
GR HR HU IE IS IT LI LT LU LV MC MK MT NL NO
PL PT RO RS SE SI SK SM TR**

(30) Priority: **02.02.2017 US 201715423248**

(43) Date of publication of application:

11.12.2019 Bulletin 2019/50

(73) Proprietors:

- **Rife, Robert**
Mount Pleasant, SC 29464 (US)
- **Vining, Leah**
Evans, GA 30809 (US)

(72) Inventors:

- **Rife, Robert**
Mount Pleasant, SC 29464 (US)
- **Vining, Leah**
Evans, GA 30809 (US)

(74) Representative: **CSY London**

Helios Court
1 Bishop Square
Hatfield
Hertfordshire AL10 9NE (GB)

(56) References cited:

WO-A1-2017/034636 US-A1- 2006 042 005
US-A1- 2006 087 097 US-A1- 2009 144 891
US-A1- 2010 219 668 US-A1- 2015 379 852
US-B1- 6 792 626 US-B2- 9 770 144

EP 3 576 587 B1

Note: Within nine months of the publication of the mention of the grant of the European patent in the European Patent Bulletin, any person may give notice to the European Patent Office of opposition to that patent, in accordance with the Implementing Regulations. Notice of opposition shall not be deemed to have been filed until the opposition fee has been paid. (Art. 99(1) European Patent Convention).

Description**FIELD OF THE INVENTION**

[0001] This invention relates to toilets generally, and is more specifically directed to a toilet that discourages users from exiting the toilet without assistance. Such a toilet is disclosed in the US2009144891.

BACKGROUND OF THE INVENTION

[0002] Healthcare facilities, including nursing homes and hospitals, are increasingly aware of fall risks and the patients and residents who are more likely to fall while residing at a healthcare facility. One situation in which falls occur is when a person exits a toilet.

[0003] A person using a toilet in a healthcare facility or nursing home, and who is a fall risk, is given privacy while using the toilet. The person is instructed to request assistance before attempting to exit the toilet. However, people are frequently embarrassed to ask for assistance, and attempt to exit the toilet without assistance. Such persons may be at risk of falling due to age, medical condition, or medications, as they transition from a seated to a standing position.

[0004] There is a need for a device that will inhibit a person who is at risk of falling from attempting to stand or attempting to exit a toilet without assistance.

SUMMARY OF THE INVENTION

[0005] The present invention is a toilet that inhibits an occupant from exiting the toilet, as further disclosed in the claims. Sensors positioned on the toilet detect the application of pressure on the toilet by an occupant that is consistent with an occupant attempting to exit the toilet, and/or movements of the occupant that are consistent with an occupant attempting to exit the toilet. The sensors cause an actuator to change the angle of the toilet seat, which inhibits exiting the toilet. The toilet may also be constructed to signal an attendant when actions by an occupant are consistent with actions indicating an attempt by the occupant to exit the toilet.

BRIEF DRAWING DESCRIPTION**[0006]**

Figure 1 is a side elevation of an embodiment of a toilet according to the invention.

Figure 2 is a front elevation of an embodiment of a toilet according to the invention.

Figure 3 is a schematic illustration of an interaction of various sensors according to an embodiment of the invention.

Figure 4 is an additional schematic illustration of the interaction of various sensors according to an embodiment of the invention.

Figure 5 shows a right side perspective view of another embodiment of the invention.

Figure 6 shows a left side perspective view of the embodiment of the invention of **Figure 5**.

DESCRIPTION OF PREFERRED EMBODIMENTS

[0007] The present invention is a toilet comprising one or more sensors that sense movements of an occupant that are indicative of a person attempting to exit a toilet. The sensors emit a signal that actuates changes in an angle of the seat of the toilet.

[0008] Upon actuation of one or more of the sensors, an angle of the seat of the toilet changes from generally horizontal to an angle that is not horizontal. In one embodiment, a top surface of the toilet changes from generally horizontal to an angle that is preferably not more than thirty degrees and more preferably not more than twenty two and a half ($22\frac{1}{2}^{\circ}$) degrees from horizontal, with the front of the toilet seat, or portion of the toilet seat closer to the front of the toilet seat, elevated relative to the rear of the toilet seat, that is, the seat is moved to incline from a rear portion of the seat to a front portion of the seat. The change in angle increases the effort required to exit the toilet, and inhibits a user from exiting from the toilet, particularly where the user is of advanced age, or has limited strength or mobility, due to medical conditions or medications.

[0009] In the embodiment shown in **Figure 1**, the actuator is positioned in the rear of the toilet, and the seat is moved to the inclined position by moving the rear of the seat downwardly. In the embodiment shown in **Figure 5** and **Figure 6**, the actuator is positioned in the front of the device. The actuator moves the front of the seat upwardly so that the inclined position of the seat is accomplished by moving the front of the seat upwardly relative to the rear of the seat.

[0010] In the embodiment shown in **Figure 1** or **Figure 5**, a toilet similar to a portable toilet used in medical facilities and nursing homes is depicted. The toilet **2** has a seat **3**, with an opening **4** in the seat that communicates with a receptacle for waste material. The seat is elevated to an appropriate height by a plurality of legs **8**, such as four legs. Arms, such as the pair of arms **10**, are spaced apart and are present on opposite sides of the toilet seat. The arms may extend upwardly from the toilet seat, providing an opening between the arms for access to the seat.

[0011] The arms **10** may be connected to a back **12** that extends upwardly from a rear portion of the toilet. One or more sensors **14** are used that sense movement by an occupant that is consistent with a person attempting to exit the toilet. Such movements typically involve moving from a seated position to a standing position. For example, a person's back moving away from the back **12** of the toilet is an indication that the person may be attempting to stand. Typically, this movement also includes a person applying pressure to one of, or both of,

the arms **10** of the toilet, so as to push themselves from a seated position to a standing position.

[0012] Accordingly, in an embodiment, the toilet seat has sensors **14** in the back **12** of the seat that emit a radio frequency signal from a sending and receiving unit that measures movement away from the back and senses the distance of the user's back from the back **12** of the toilet. **Figure 2**. Other sensor types that measure distance, such as distance measuring devices that use lasers, may be used as sensors **14**. In one embodiment, when the user's back moves to a pre-determined distance from a sensor or sensors **14**, the back of the toilet seat is positioned lower than the front of the toilet seat to inhibit the person's attempt to exit or stand up. A signal may be emitted to an attendant as described herein anytime that the toilet seat moves due to actuation by a signal from a sensor.

[0013] In another embodiment, one or more of the sensors **14** sense motion. The motion sensors are calibrated to actuate the actuator due to more movement by the user that is more than normal shifting about while seated.

[0014] In an embodiment, one or more pressure sensors **18** are located in the arms of the device. A plurality of spaced apart pressure sensors may be used, since different users will apply pressure to the arms in different places while attempting to stand up or exit the toilet. The pressure sensors are calibrated so that when pressure that is significant enough to indicate a user's attempt to stand or exit the toilet, the toilet seat moves to an inclined position as described herein to inhibit such movement.

[0015] Another change in pressure on the toilet that is indicative of a person attempting to stand is applying a force in a direction that is toward the rear of the toilet. In another embodiment, one or more pressure sensors **28**, which may be load cells, are located in the arms of the device sense rearward pressure on the arms **10**, as demonstrated by the arrow on the arm in **Figure 1**. The pressure sensors **28** measure such rearward pressure and actuate the lowering of the rear of the toilet seat in response to the pressure. The pressure sensors are calibrated so that when pressure that is significant enough to indicate a user's attempt to stand or exit the toilet, the toilet seat inclines to inhibit such movement. The pressure sensors **28** are preferred to be used with pressure sensors **18**, but may be used independently of each other.

[0016] The dotted line and vertical arrow in **Figure 1** demonstrate exemplary movement of the toilet seat **3**. A change of the angle of the toilet seat **3** from substantially horizontal to an incline, with the rear of the toilet seat lower than the front of the toilet seat, or a portion of the toilet seat that is closer to the front, may be accomplished by hinging a portion of the toilet seat so that it pivots. The actuators **20, 120** may be an air or hydraulic cylinder that may be used to pull the rear of the toilet seat down, or push the front of the seat up in another embodiment, in response to movement of the user, and/or pressure applied to the arms of the toilet as described above. The

actuators' normal position holds the seat and occupant in a generally horizontal position.

[0017] In another embodiment, the actuators **20, 120** may be an electrically powered actuator. An electric motor with rack and pinion gear may be used as an actuator to lower the seat. The electric motor may be powered by a battery, particularly where portability of the toilet is desired. In one embodiment, two batteries **42, 44** provide power redundancy.

[0018] The actuators **20, 120** may be extended to support the toilet seat **3** in a generally horizontal position under normal use, but upon receiving a signal from a motion sensor, pressure sensor or other sensor, or a combination, the actuator retracts so as to push the front of the seat upwardly. The toilet seat is repositioned at an angle, which is preferred to not to exceed thirty degrees from horizontal and is more preferred to not exceed twenty two and a half ($22\ 1/2^\circ$) degrees from horizontal. The incline of the toilet seat will inhibit, although not necessarily prevent, a user from standing or exiting the toilet.

[0019] In another embodiment, lowering of the rear of toilet seat **3** may be terminated if the sensor or sensors that have initiated actuation of the actuators **20, 120** senses that movement by the user is terminated. For example, if pressure on the arms is terminated, or movement away from the seat back is terminated and the user moves his or her back against the seat back, movement of the seat may be terminated at less than full movement.

[0020] In another embodiment, upon sensing that movement is terminated, the seat returns to its original position, or alternatively, only if the user's back is positioned against the seat back as sensed by sensors **14** does the seat return to its original position. In these embodiments, the device is preferred to again lower the rear of the seat if movement is sensed.

[0021] In a preferred embodiment, actuation of one or more of the sensors also actuates an alert provided to an attendant so that help is summoned to the toilet and to the user of the toilet. Such alert may be an audible or visual signal **40** provided at a central location, such as a nurse's station, or a signal that is provided to a mobile telephone or other receiving device. A call button **30** may be positioned on the device so that the user may intentionally press the button to seek assistance. Wireless communications may be used to alert an assistant.

[0022] In another embodiment, the actuator for the seat is actuated by a mechanical switch. For example, a barrier, such as crossbar **22, 122** is positioned between the arms at the front of the toilet. **Figure 2; Figure 6**. The barrier may be pivotally mounted **26** at one end of the barrier. In yet another embodiment, two barriers or crossbars **102** are used, with one barrier pivotally mounted to each of the arms. If the user attempts to exit the toilet by pushing the barrier away from the opening, a crossbar sensor senses movement of the barrier. The crossbar sensor **24** may be a switch that initiates actuation of the actuators **20, 120**. Actuating the crossbar sensor by pushing against it could lock the crossbar from further

movement, preventing the occupant from exiting the toilet. However, it is not deemed to be desirable to have a locking bar which would restrain or materially inhibit a person from exiting the toilet. A bar that locks or has significant resistance could result in the user feeling unduly restrained.

[0023] In another embodiment, the actuator may be mounted to push or lift the back of the seat above the front of the seat in order to assist exiting the toilet. In this embodiment, the maximum angle of the seat is limited to a maximum of about 30° from horizontal, and is more preferably limited to about 22 1/2°, from horizontal. Lifting the rear of the toilet seat **3** relative to the front is preferred to be actuated by a switch or other actuation device to which the user of the toilet does not have access while occupying the toilet. Actuation of this feature is preferred to be available only when an assistant is present. Actuation may be provided by a switch that communicates with the actuator or actuators **20**, **120**, such as a mechanical switch or a wireless remote communications device.

[0024] **Figure 3** and **Figure 4** demonstrate the interrelationship of the electromechanical features of the invention according to an embodiment of the invention. The motion or distance sensors **14**, load cells **18**, and cross-bar sensor **24** communicate with a wireless transmitter that may include a signal amplifier. Communications may be via a local area wireless computer networking technology (Wi-Fi) connective devices, or devices that provide short range wireless communications, including but not limited to those communications devices operating at frequencies between 2402 and 2480 MHz, or 2400 and 2483.5 MHz, such as Bluetooth® devices. The wireless transmitter **30** may be connected to a microcomputer **32** that actuates the actuators **20**, **120**. The wireless transmitter may also actuate an audible or visual signal, which is demonstrated by the call bell **36** in **Figure 3**. The wireless transmitter may also communicate conditions of the sensors and the toilet to a wireless mobile device **34** such as a smartphone.

[0025] As shown in an embodiment of **Figure 4**, exceeding force levels or movement sensed by the sensors actuates signaling (audio and/or visual) and/or operation of the actuators or actuator **20**, **120**. The use of one or more programmable logic controllers (PLC) allows the force on the sensors such as the load cells to be programmed as required. Some users, due to size or physical condition, will require more or less sensitivity on the sensors, which may be varied by the use of the programmable logic controllers.

[0026] Load cells may be used as sensor for sensing pressure as stated herein. A load cell is a transducer that creates an electrical signal whose magnitude is positively related to the magnitude of force applied. Some load cells measure deformation due to load and produce the electrical signal, such as strain gauge and piezo-electric load cells. The load cells **18** produce an electrical signal that actuates the movement of the seat when the force exceeds a preset level. Normal arm pressure from the us-

er's movement while sitting on the toilet does not result in actuation of the sensors or the actuator, but pushing down on the arms, or pushing the arms toward the rear, as the occupant attempts to exit the toilet increases the magnitude of the signal generated by the load cell to a threshold that causes movement of the toilet seat as described herein. The threshold may be variable as required for the application of the toilet. It is believed that a minimum pressure of 30 pounds per square inch as measured by the sensor will indicate that pressure is applied to an arm of the toilet is consistent with a person exiting the toilet.

[0027] In an embodiment, downward pressure on either or both of the arms at a force that is in excess of normal movement of the user's hands and arms, and consistent with pressure placed on the toilet's arms when pushing down on the arms when exiting the toilet, is sufficient to actuate movement of the toilet seat by the actuators. In another embodiment, rearward pressure on either or both of the arms at a force that is in excess of normal movement of the user's hands and arms, and consistent with rearward pressure placed on the toilet's arms when pushing away from the toilet when exiting, is sufficient to actuate movement of the toilet seat by the actuators.

[0028] In an embodiment, the device does not have a receptacle **6** as shown in **Figs. 1** and **2**. Rather, the toilet is positioned over an existing permanent toilet. The opening **4** in the seat **3** communicates with the opening in the plumbed in toilet, and is positioned over the permanent, plumbed in toilet. With a receptacle **6** in place as shown in **Figure 1**, the device may be used in close proximity to a bed, so that a limited mobility user need only travel a short distance to use the toilet.

[0029] The features discussed above with regard to an embodiment having actuators **20** positioned at or near the rear portion of the seat (**Figure 1**, **Figure 2**) may also be applied to an embodiment having actuators **120** positioned (**Figure 5** and **Figure 6**) at the front of the seat.

[0030] The seat in the embodiment of **Figure 5** and **Figure 6** is shown as being pivotally mounted in the rear portion of the seat, which is referred to as being hinged. As shown in the drawings, a pin is positioned in a mounting arm **58** that is part of the rear portion of the seat that acts as a hinge and allows the rear of the seat to pivot relative to the frame of the toilet. The mounting arm **58** may slide or telescope relative to the seat to facilitate the movement of the seat as it moves from the position in **Figure 5** to the position in **Figure 6**, and back.

[0031] The toilet is preferred to be portable, and may be fitted with a caster **50** at each of the four (4) legs. The casters may be fitted with a locking device **54** to selectively retard movement of the toilet. A handle **52** may be provided for pushing or pulling the toilet.

[0032] A control pendant may be provided. The control pendant **46** allows an operator to position or reposition the toilet seat by means of the actuators. The control pendant may also clear the call feature, indicated battery

charge level, or provide other monitoring and control functions. The control pendant is preferred to be positioned on the back of the toilet where it is not easily accessible to a person seated in the toilet.

Claims

1. A toilet (2), the toilet comprising:

a seat (3) having an opening (4) therein and wherein the seat is hinged in the rear portion of the seat;

a seat back (12) connected to the seat;

a first arm (10) having a first pressure sensor (18) and a second arm having a second pressure sensor, the first arm and the second arm being spaced apart and positioned above the seat;

an actuator (20) that moves the seat to a position wherein the seat inclines upwards from the hinged rear portion of the seat to a front portion of the seat;

wherein, in use, the first pressure sensor senses pressure on the first arm and the second pressure sensor senses pressure on the second arm, and upon the first pressure sensor or the second pressure sensor sensing pressure, a signal is transmitted to the actuator (20), whereupon the actuator moves the seat to incline upwards from the hinged rear portion of the seat to the front portion of the seat.

2. A toilet as described in Claim 1, further comprising a seat back sensor (14) positioned in the seat back (12), wherein, in use, the seat back sensor detects a change in distance of an occupant from the sensor, and upon the distance exceeding a limit, a signal is transmitted to the actuator, whereupon the actuator moves the seat to incline the seat from the hinged rear portion of the seat to the front portion of the seat.

3. A toilet as described in Claim 1 or Claim 2, further comprising:

a crossbar (22) positioned between the pair of spaced apart arms; and
a crossbar sensor (24);

wherein, in use, movement of the crossbar is detected by the crossbar sensor and a signal is transmitted to the actuator, whereupon the actuator moves the seat to incline the seat upwards from the hinged rear portion of the seat to the front portion of the seat.

4. A toilet as described in Claim 1 or Claim 2, further comprising:

a crossbar positioned between the pair of spaced apart arms; and

a crossbar sensor;

wherein, in use, movement of the crossbar is detected by the crossbar sensor and the crossbar sensor transmits an audible signal or visual signal to a location that is remote from the toilet.

5. A toilet as described in Claim 1 or Claim 2, wherein the first pressure sensor senses downward pressure on the first arm and the second pressure sensor senses downward pressure on the second arm, and upon the first pressure sensor or the second pressure sensor sensing downward pressure, a signal is transmitted to the actuator, whereupon the actuator moves the seat to incline the seat from the rear portion of the seat to the front portion of the seat.

6. A toilet as described in Claim 1 or Claim 2, wherein a pressure sensor senses rearward pressure on the first arm and an additional pressure sensor senses rearward pressure on the second arm, and upon the pressure sensor or the additional pressure sensor sensing rearward pressure, a signal is transmitted to the actuator, whereupon the actuator moves the seat to incline the seat from the rear portion of the seat to the front portion of the seat.

7. A toilet as described in Claim 1 or Claim 2, wherein the actuator is powered by air pressure.

8. A toilet as described in Claim 1 or Claim 2, wherein the actuator is powered by hydraulic pressure.

9. A toilet as described in Claim 1 or Claim 2, wherein the actuator is electrically powered.

Patentansprüche

1. Toilette (2), umfassend:

einen Sitz (3) mit einer Öffnung (4) darin und wobei der Sitz im hinteren Abschnitt des Sitzes angelenkt ist,

eine Rückenlehne (12), die mit dem Sitz verbunden ist,

einen ersten Arm (10) mit einem ersten Drucksensor (18) und einen zweiten Arm mit einem zweiten Drucksensor, wobei der erste Arm und der zweite Arm voneinander beabstandet und oberhalb des Sitzes positioniert sind,

ein Betätigungselement (20), das den Sitz zu einer Position bewegt, in der der Sitz von dem angelenkten hinteren Abschnitt des Sitzes zu einem vorderen Abschnitt des Sitzes nach oben geneigt ist,

wobei im Gebrauch der erste Drucksensor

- Druck auf den ersten Arm erfasst und der zweite Drucksensor Druck auf den zweiten Arm erfasst, und auf das Erfassen von Druck durch den ersten Drucksensor oder den zweiten Drucksensor ein Signal an das Betätigungselement (20) übertragen wird, woraufhin das Betätigungselement den Sitz so bewegt, dass er von dem angelenkten hinteren Abschnitt des Sitzes zu dem vorderen Abschnitt des Sitzes nach oben geneigt wird.
2. Toilette nach Anspruch 1, ferner umfassend einen Rückenlehnsensor (14), der in der Rückenlehne (12) positioniert ist, wobei der Rückenlehnsensor im Gebrauch eine Veränderung im Abstand eines Nutzers von dem Sensor erkennt und daraufhin, dass der Abstand eine Grenze überschreitet, ein Signal an das Betätigungselement übertragen wird, woraufhin das Betätigungselement den Sitz so bewegt, dass er von dem angelenkten hinteren Abschnitt des Sitzes zu dem vorderen Abschnitt des Sitzes geneigt wird.
3. Toilette nach Anspruch 1 oder Anspruch 2, ferner umfassend:
- eine Querstange (22), die zwischen dem Paar beabstandeter Arme positioniert ist, und einen Querstangensensor (24),
- wobei von dem Querstangensensor im Gebrauch eine Bewegung der Querstange erkannt wird und ein Signal an das Betätigungselement übertragen wird, woraufhin das Betätigungselement den Sitz so bewegt, dass er von dem angelenkten hinteren Abschnitt des Sitzes zu dem vorderen Abschnitt des Sitzes nach oben geneigt wird.
4. Toilette nach Anspruch 1 oder Anspruch 2, ferner umfassend:
- eine Querstange, die zwischen dem Paar beabstandeter Arme positioniert ist, und einen Querstangensensor, wobei von dem Querstangensensor im Gebrauch eine Bewegung der Querstange erkannt wird und der Querstangensensor ein hörbares Signal oder ein sichtbares Signal an eine Stelle überträgt, die fern der Toilette liegt.
5. Toilette nach Anspruch 1 oder 2, wobei der erste Drucksensor einen nach unten gerichteten Druck auf den ersten Arm erfasst und der zweite Drucksensor einen nach unten gerichteten Druck auf den zweiten Arm erfasst und daraufhin, dass der erste Drucksensor oder der zweite Drucksensor einen nach unten gerichteten Druck erfasst, ein Signal an das Betätigungselement übertragen wird, woraufhin das Betätigungselement den Sitz so bewegt, dass er von dem hinteren Abschnitt des Sitzes zu dem vorderen Abschnitt des Sitzes geneigt wird.
6. Toilette nach Anspruch 1 oder Anspruch 2, wobei ein Drucksensor einen nach hinten gerichteten Druck auf den ersten Arm erfasst und ein zusätzlicher Drucksensor einen nach hinten gerichteten Druck auf den zweiten Arm erfasst und auf das Erfassen von nach hinten gerichtetem Druck durch den Drucksensor oder den zusätzlichen Drucksensor ein Signal an das Betätigungselement übertragen wird, woraufhin das Betätigungselement den Sitz so bewegt, dass er von dem hinteren Abschnitt des Sitzes zu dem vorderen Abschnitt des Sitzes geneigt wird.
7. Toilette nach Anspruch 1 oder Anspruch 2, wobei das Betätigungselement durch Luftdruck betätigt wird.
8. Toilette nach Anspruch 1 oder Anspruch 2, wobei das Betätigungselement durch Hydraulikdruck betätigt wird.
9. Toilette nach Anspruch 1 oder Anspruch 2, wobei das Betätigungselement elektrisch betätigt wird.
- 30 Revendications**
1. Toilettes (2), les toilettes comprenant :
- un siège (3) présentant une ouverture (4) en son sein et dans lesquelles le siège est articulé dans la partie arrière du siège ;
un dossier (12) raccordé au siège ;
un premier bras (10) présentant un premier capteur de pression (18) et un second bras présentant un second capteur de pression, le premier bras et le second bras étant espacés et positionnés au-dessus du siège ;
un actionneur (20) qui déplace le siège vers une position dans laquelle le siège s'incline vers le haut de la partie arrière articulée du siège à une partie avant du siège ;
dans lesquelles, lors de l'utilisation, le premier capteur de pression détecte une pression sur le premier bras et le second capteur de pression détecte une pression sur le second bras, et lorsque le premier capteur de pression ou le second capteur de pression détecte une pression, un signal est transmis à l'actionneur (20), après quoi l'actionneur déplace le siège pour son inclinaison vers le haut de la partie arrière articulée du siège à la partie avant du siège.
2. Toilettes selon la revendication 1, comprenant en

- outre un capteur de dossier (14) positionné dans le dossier (12), dans lesquelles, lors de l'utilisation, le capteur de dossier détecte un changement de distance d'un occupant par rapport au capteur et, lorsque la distance dépasse une limite, un signal est transmis à l'actionneur, après quoi l'actionneur déplace le siège pour incliner le siège de la partie arrière articulée du siège à la partie avant du siège.
- 3.** Toilettes selon la revendication 1 ou la revendication 2, comprenant en outre :
- une barre transversale (22) positionnée entre la paire de bras espacés ; et
 - un capteur de barre transversale (24) ;
- dans lesquelles, lors de l'utilisation, un mouvement de la barre transversale est détecté par le capteur de barre transversale et un signal est transmis à l'actionneur, après quoi l'actionneur déplace le siège pour incliner le siège vers le haut de la partie arrière articulée du siège à la partie avant du siège.
- 4.** Toilettes selon la revendication 1 ou la revendication 2, comprenant en outre :
- une barre transversale positionnée entre la paire de bras espacés ; et
 - un capteur de barre transversale ;
- dans lesquelles, lors de l'utilisation, un mouvement de la barre transversale est détecté par le capteur de barre transversale et le capteur de barre transversale transmet un signal sonore ou un signal visuel à un emplacement qui est distant des toilettes.
- 5.** Toilettes selon la revendication 1 ou la revendication 2, dans lesquelles le premier capteur de pression détecte une pression vers le bas sur le premier bras et le second capteur de pression détecte une pression vers le bas sur le second bras, et lorsque le premier capteur de pression ou le second capteur de pression détecte une pression vers le bas, un signal est transmis à l'actionneur, après quoi l'actionneur déplace le siège pour incliner le siège de la partie arrière du siège à la partie avant du siège.
- 6.** Toilettes selon la revendication 1 ou la revendication 2, dans lesquelles un capteur de pression détecte une pression vers l'arrière sur le premier bras et un capteur de pression supplémentaire détecte une pression vers l'arrière sur le second bras, et lorsque le capteur de pression ou le capteur de pression supplémentaire détecte une pression vers l'arrière, un signal est transmis à l'actionneur, après quoi l'actionneur déplace le siège pour incliner le siège de la partie arrière du siège à la partie avant du siège.
- 7.** Toilettes selon la revendication 1 ou la revendication 2, dans lesquelles l'actionneur est alimenté par pression d'air.
- 8.** Toilettes selon la revendication 1 ou la revendication 2, dans lesquelles l'actionneur est alimenté par pression hydraulique.
- 9.** Toilettes selon la revendication 1 ou la revendication 2, dans lesquelles l'actionneur est alimenté électriquement.

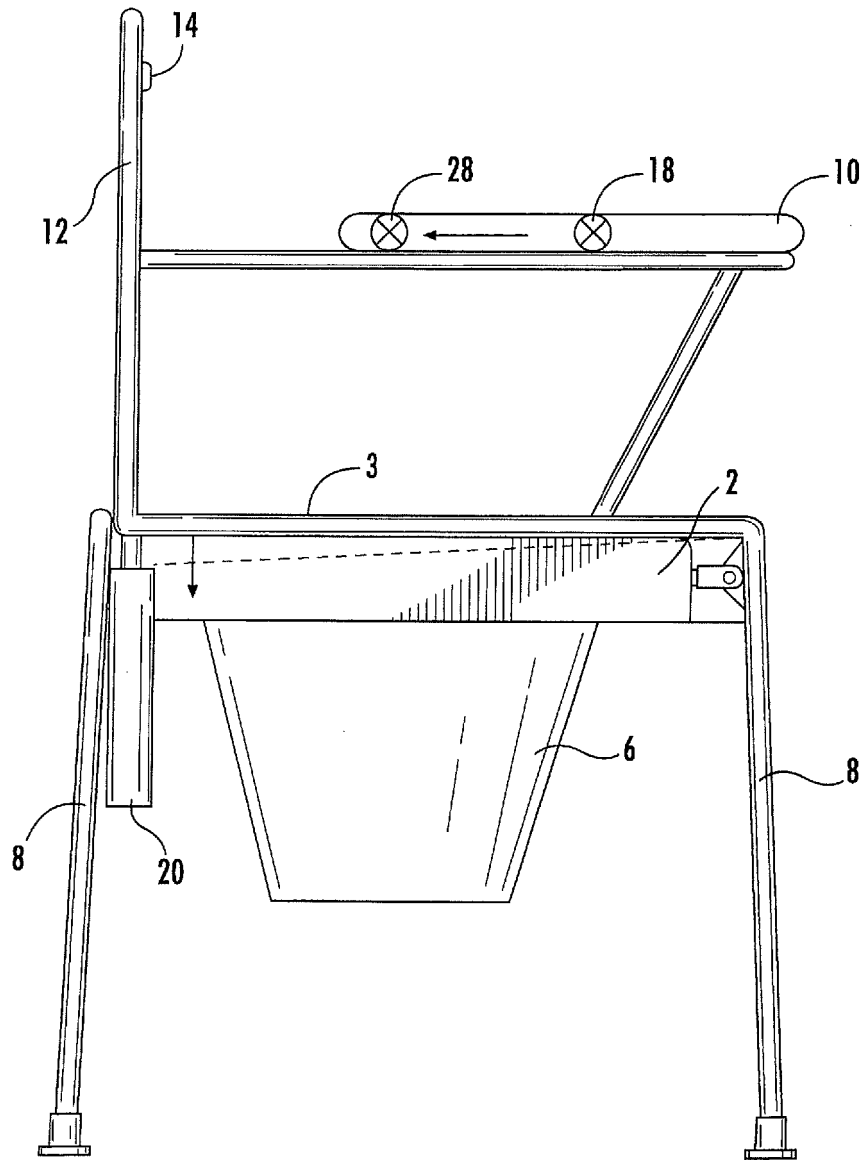

FIG. 1

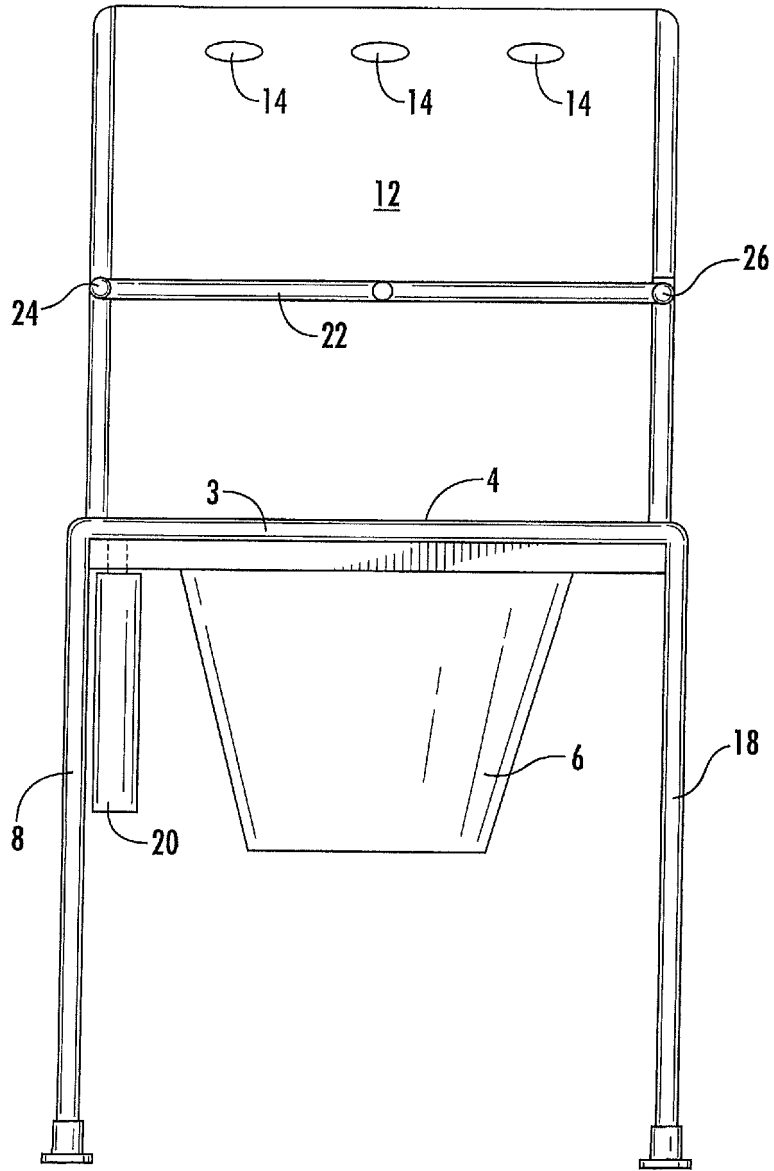

FIG. 2

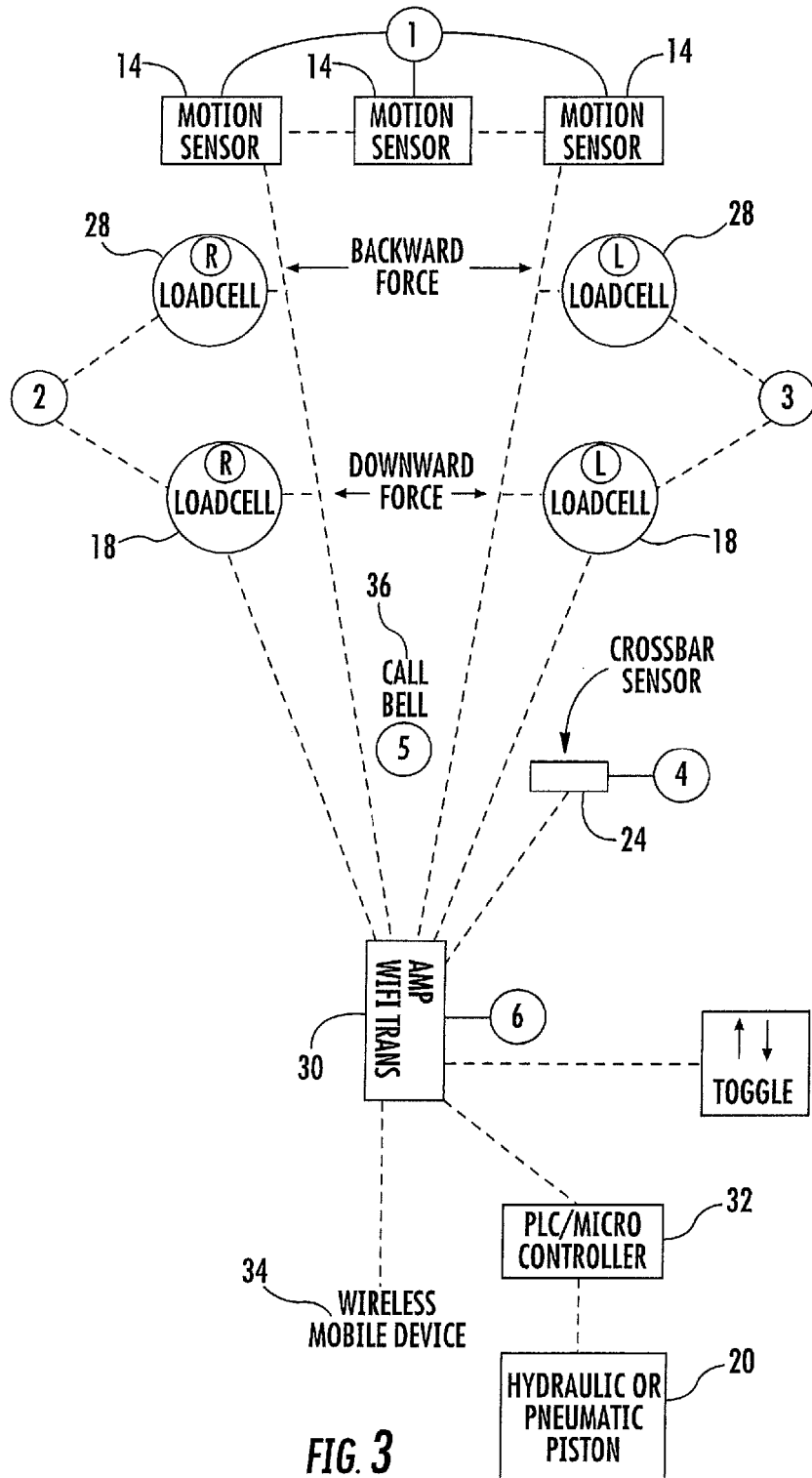
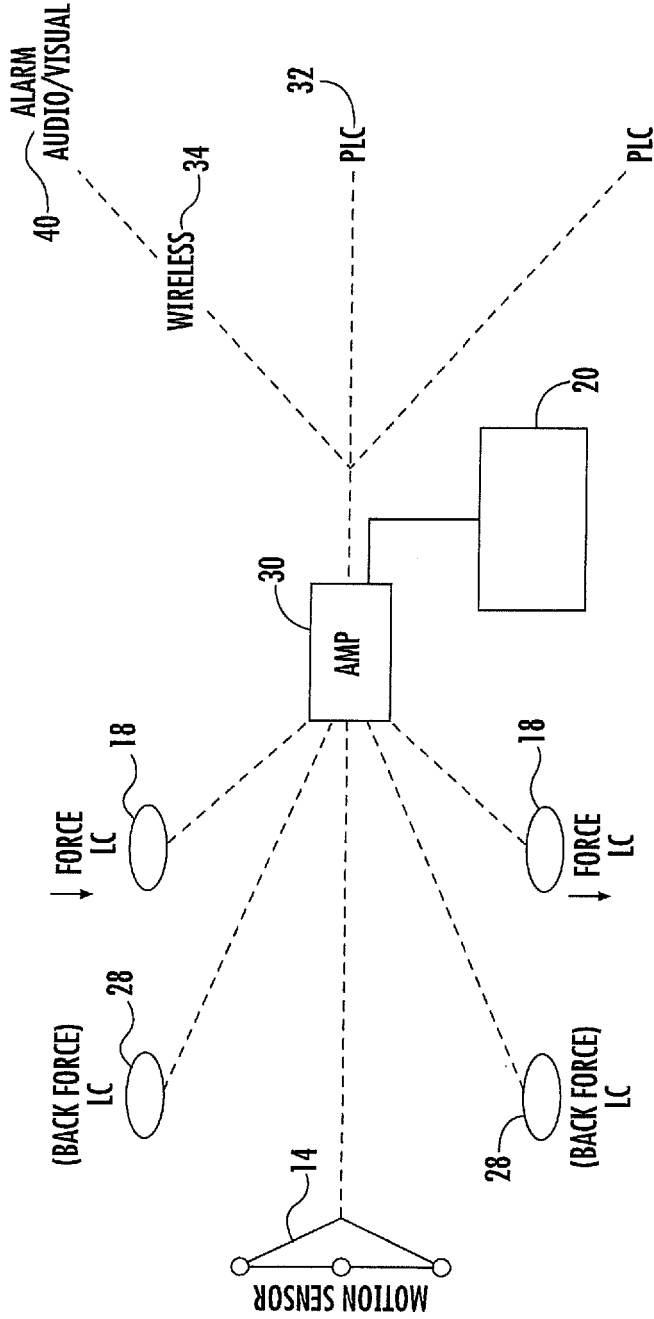

FIG. 3



MOTION SENSORS

- NORMAL MOVEMENT → SIGNAL TO VISUAL INDICATOR
- EXCEEDING PREDETERMINED DISTANCE → AUDIO
- EXCEEDING DISTANCE AND FORCE ON ONE OR MORE LOAD CELLS(SENSORS) → AUDIO VISUAL ALARM AND ↑ SEAT MOVEMENT
- CONTINUED FORCE AND/OR DISENGAGING CROSSBAR → CONTINUED ↓ MOVEMENT NOT TO EXCEED 22.5°

FIG. 4

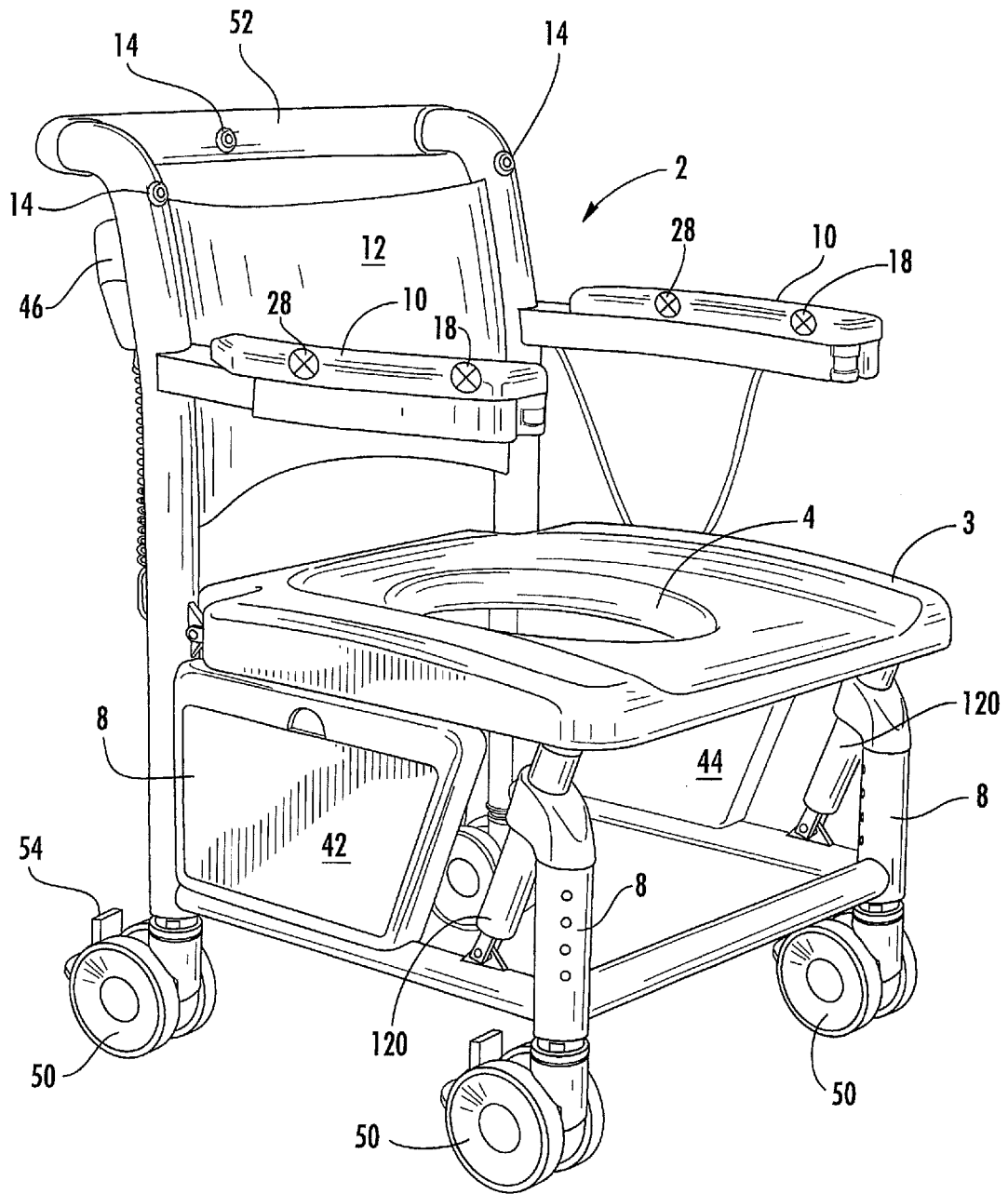

FIG. 5

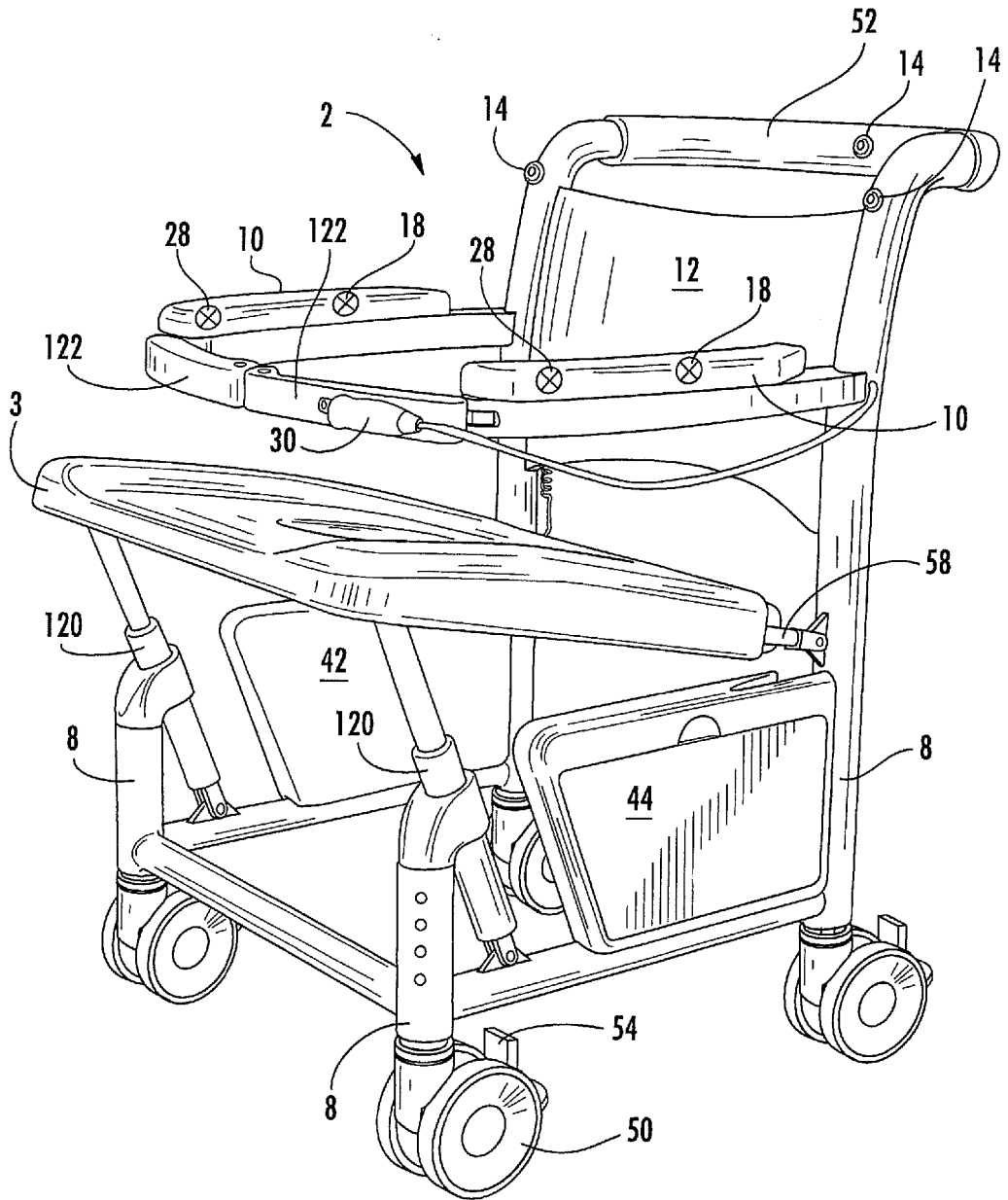

FIG. 6

REFERENCES CITED IN THE DESCRIPTION

This list of references cited by the applicant is for the reader's convenience only. It does not form part of the European patent document. Even though great care has been taken in compiling the references, errors or omissions cannot be excluded and the EPO disclaims all liability in this regard.

Patent documents cited in the description

- US 2009144891 A [0001]