



(86) Date de dépôt PCT/PCT Filing Date: 2011/09/13
 (87) Date publication PCT/PCT Publication Date: 2012/03/22
 (85) Entrée phase nationale/National Entry: 2013/03/12
 (86) N° demande PCT/PCT Application No.: CA 2011/001044
 (87) N° publication PCT/PCT Publication No.: 2012/034225
 (30) Priorité/Priority: 2010/09/13 (US61/382,097)

(51) Cl.Int./Int.Cl. *H02J 7/00* (2006.01),
B60L 11/18 (2006.01), *B60S 5/00* (2006.01)
 (71) Demandeur/Applicant:
ADDENERGIE TECHNOLOGIES INC., CA
 (72) Inventeurs/Inventors:
TREMBLAY, LOUIS, CA;
DESJARDINS, MICHAEL, CA
 (74) Agent: FASKEN MARTINEAU DUMOULIN LLP

(54) Titre : STATION DE CHARGE MODULAIRE
 (54) Title: MODULAR CHARGING STATION

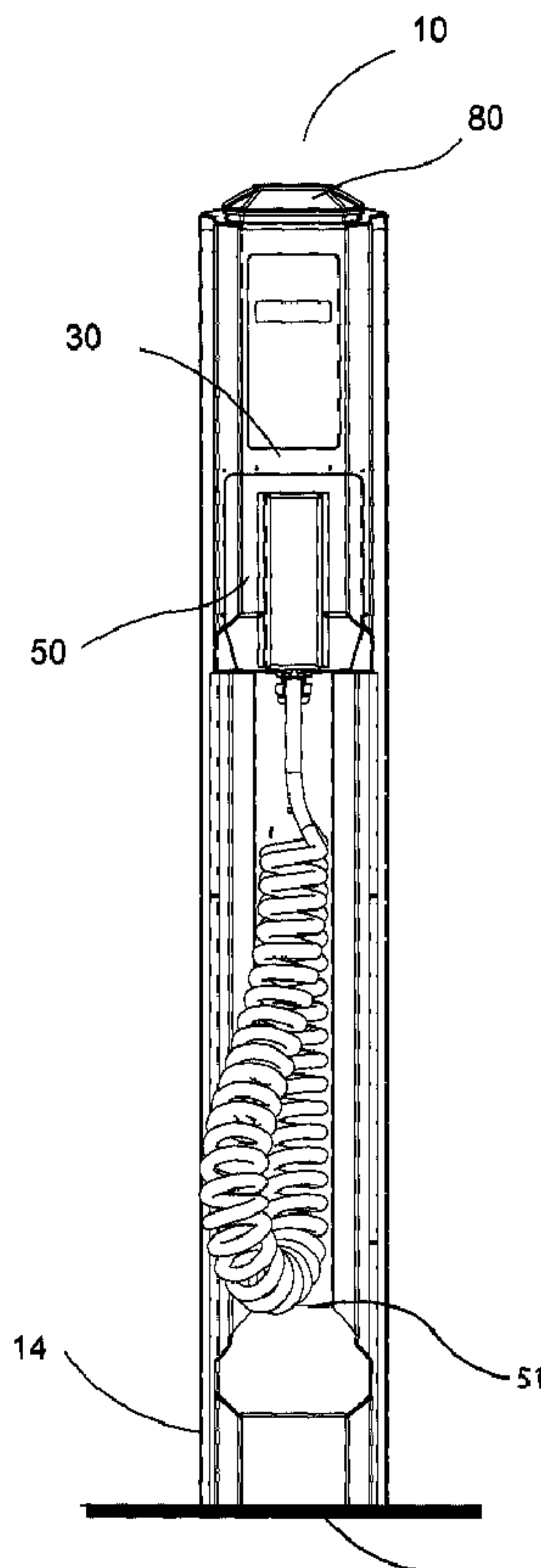

FIG.1

(57) Abrégé/Abstract:

A modular charging station for charging an electric vehicle, the modular charging station comprising: a frame having a receiving portion; a control unit removably secured to the receiving portion of the frame and electrically connectable to a source of electrical



(57) **Abrégé(suite)/Abstract(continued):**

energy, the control unit for selectively controlling access to the electrical energy; and a distributing unit removably secured to the frame, electrically connected to the control unit for receiving the electrical energy therefrom, and electrically connectable to the electric vehicle for providing the electrical energy to the electric vehicle, a powering of the distributing unit being controlled by the control unit.

(12) INTERNATIONAL APPLICATION PUBLISHED UNDER THE PATENT COOPERATION TREATY (PCT)

(19) World Intellectual Property Organization
International Bureau(43) International Publication Date
22 March 2012 (22.03.2012)(10) International Publication Number
WO 2012/034225 A1

(51) International Patent Classification:

H02J 7/00 (2006.01) *B60L 11/18* (2006.01)
B60S 5/00 (2006.01)rue Einstein, Bureau 130, Québec, Québec G1P 4R1
(CA).

(21) International Application Number:

PCT/CA2011/001044

(72) Inventors; and

(75) Inventors/Applicants (*for US only*): **TREMBLAY, Louis** [CA/CA]; 735, Chanoine-Scott Avenue, Apt. 3, Québec, Québec G1V 3M9 (CA). **DESJARDINS, Michael** [CA/CA]; 735, Chanoine-Scott Avenue, Apt. 3, Québec, Québec G1V 3M9 (CA).

(22) International Filing Date:

13 September 2011 (13.09.2011)

(25) Filing Language:

English

(74) Agent: **FASKEN MARTINEAU DUMOULIN LLP**; Stock Exchange Tower, Suite 3700, P.O. Box 242, 800 Square Victoria, Montreal, Québec H4Z 1E9 (CA).

(26) Publication Language:

English

(30) Priority Data:

61/382,097 13 September 2010 (13.09.2010) US

(81) Designated States (*unless otherwise indicated, for every kind of national protection available*): AE, AG, AL, AM, AO, AT, AU, AZ, BA, BB, BG, BH, BR, BW, BY, BZ, CA, CH, CL, CN, CO, CR, CU, CZ, DE, DK, DM, DO,(71) Applicant (*for all designated States except US*): **AD-DÉNERGIE TECHNOLOGIES INC.** [CA/CA]; 2750,*[Continued on next page]*

(54) Title: MODULAR CHARGING STATION

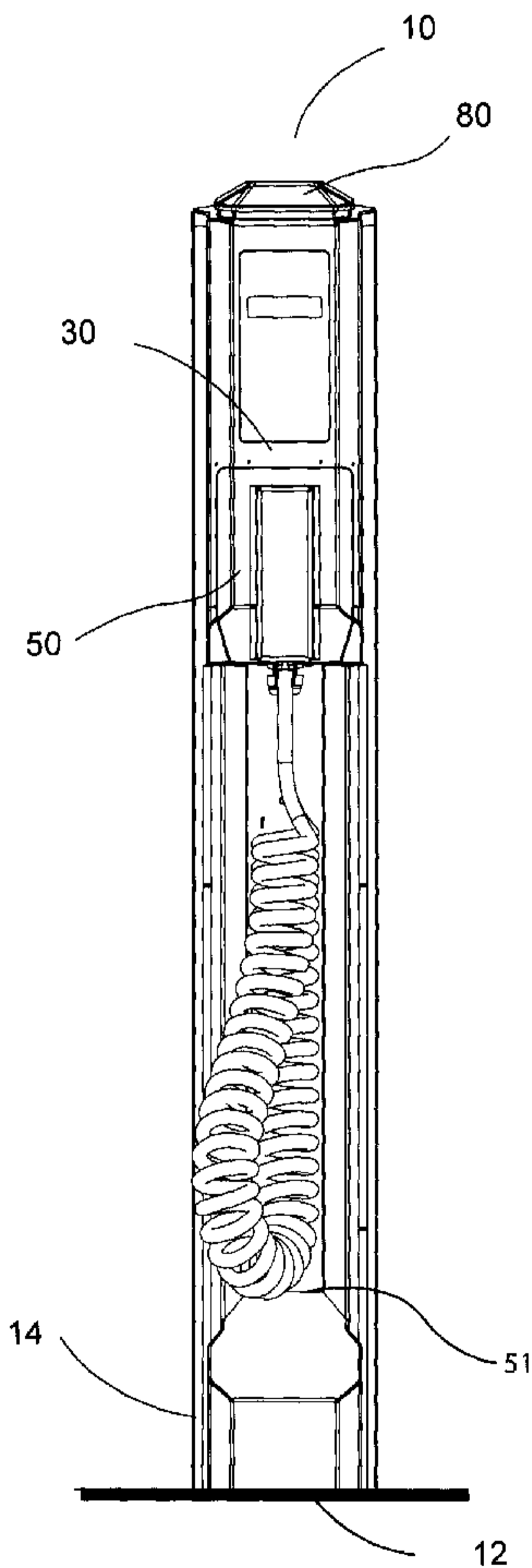

FIG.1

(57) Abstract: A modular charging station for charging an electric vehicle, the modular charging station comprising: a frame having a receiving portion; a control unit removably secured to the receiving portion of the frame and electrically connectable to a source of electrical energy, the control unit for selectively controlling access to the electrical energy; and a distributing unit removably secured to the frame, electrically connected to the control unit for receiving the electrical energy therefrom, and electrically connectable to the electric vehicle for providing the electrical energy to the electric vehicle, a powering of the distributing unit being controlled by the control unit.

WO 2012/034225 A1

WO 2012/034225 A1 

DZ, EC, EE, EG, ES, FI, GB, GD, GE, GH, GM, GT, HN, HR, HU, ID, IL, IN, IS, JP, KE, KG, KM, KN, KP, KR, KZ, LA, LC, LK, LR, LS, LT, LU, LY, MA, MD, ME, MG, MK, MN, MW, MX, MY, MZ, NA, NG, NI, NO, NZ, OM, PE, PG, PH, PL, PT, QA, RO, RS, RU, RW, SC, SD, SE, SG, SK, SL, SM, ST, SV, SY, TH, TJ, TM, TN, TR, TT, TZ, UA, UG, US, UZ, VC, VN, ZA, ZM, ZW.

GM, KE, LR, LS, MW, MZ, NA, SD, SL, SZ, TZ, UG, ZM, ZW), Eurasian (AM, AZ, BY, KG, KZ, MD, RU, TJ, TM), European (AL, AT, BE, BG, CH, CY, CZ, DE, DK, EE, ES, FI, FR, GB, GR, HR, HU, IE, IS, IT, LT, LU, LV, MC, MK, MT, NL, NO, PL, PT, RO, RS, SE, SI, SK, SM, TR), OAPI (BF, BJ, CF, CG, CI, CM, GA, GN, GQ, GW, ML, MR, NE, SN, TD, TG).

(84) Designated States (*unless otherwise indicated, for every kind of regional protection available*): ARIPO (BW, GH,

Published:

— *with international search report (Art. 21(3))*

MODULAR CHARGING STATION

CROSS REFERENCE TO RELATED APPLICATION

This application claims priority of US Provisional Patent Application having serial number 61/382,097, which was filed on September 13, 2010 and is entitled
5 "MODULAR CHARGING STATION", the specification of which is hereby incorporated by reference.

FIELD OF THE INVENTION

This invention relates to electrical distribution and dispensing. More precisely, the invention pertains to a modular charging station for providing electrical energy to
10 batteries powered devices such as electric or plug-in hybrid vehicles for example. The charging station has a modular design enabling various configurations.

BACKGROUND OF THE INVENTION

Electrical vehicles become widely used. Some of them are hybrid type vehicles having both an electric motor coupled to an electric rechargeable battery and an
15 internal conventional combustion engine.

Recharging of hybrid vehicles may take place from the internal combustion engine and/or from waste energy recovered during braking phases. They may also be recharged by simply buying electricity and transferring it into the batteries, provided they have the plug-in capability.

20 Typically, the user will recharge the electric battery of his vehicle in connecting the battery to the power grid via a suitable plug. In this case, the user will generally use the connection to the power grid that is available at his residence.

Some fully electric vehicles may not yet have an autonomy suitable for enabling the user to travel a long way without recharging the batteries, once they are
25 depleted, to further postpone the recharging of the batteries of the vehicle. In this case, the user may have to recharge his batteries outside his residence, for example in a charging station available to the public upon payment of a fee.

Different types of charging stations and associated methods adapted for distributing electricity to electric vehicles have been proposed.

As known to the skilled addressee, for level 1 and level 2, a charger is typically provided in the car, so the charging stations are typically energy access spots for electric cars. Those stations do not know in any case the parameters of the batteries. It is the charger in the car that performs the charging, knowing the proper parameters of the batteries pack. In level 3 chargers, the car controls the fast charging station in a master-slave relationship.

These charging stations, when used in harsh climatic conditions such as during winter in northern countries like Canada, may not be very convenient for the user. Indeed, they may be inoperative more often and they may also contribute to soil the user suit in the case the charging cable has not been properly replaced by the previous user.

Furthermore, the installation of a complete set of electric charging stations may be quite expensive. Thus, once they are installed, the manager of the stations may not accept to change the charging stations often, even if not well adapted for an optimal charging of the vehicles.

In order to better accommodate the users of such electric vehicles and also in order to encourage the expansion of the use of such vehicles, convenient charging stations available at different locations and adapted for recharging the vehicles under optimal conditions are needed. Moreover, a charging station that may be easily updated according to new technological features would be advantageous for a manager of a complete set of charging station.

It is therefore desirable to provide an improved charging station that would reduce at least one of the above mentioned drawbacks.

BRIEF SUMMARY

In accordance with a broad aspect, there is provided a modular charging station for charging an electric vehicle, the modular charging station comprising: a frame having a receiving portion; a control unit removably secured to the receiving

portion of the frame and electrically connectable to a source of electrical energy, the control unit for selectively controlling access to the electrical energy; and a distributing unit removably secured to the frame, electrically connected to the control unit for receiving the electrical energy therefrom, and electrically
5 connectable to the electric vehicle for providing the electrical energy to the electric vehicle, a powering of the distributing unit being controlled by the control unit.

In one embodiment, the control unit comprises a receiving cavity for removably receiving the distributing unit therein. The shape of a rear face of the control unit
10 may match the shape of the receiving cavity for a snugly relationship between the control unit and the frame. In one embodiment, the frame comprises an elongated V-shaped extrusion.

In one embodiment, the control unit comprises a first electrical connector positioned in the receiving cavity and electrically connected to the source of
15 electrical energy, and the distributing unit comprises a second electrical connector. The first and second electrical connectors are positioned so that an insertion of the distributing unit in the receiving cavity electrically connects the first and second electrical connectors together.

In one embodiment, the control unit comprises a switch for activating a powering
20 of the distributing unit, a first electrical connector connected to the switch and connectable to the source of electrical energy, and a second electrical connector connected to the switch and the distributing unit. The distributing unit may comprise a third electrical connector electrically connected to the second electrical connector for receiving the electrical energy therefrom.

25 In one embodiment, the first, second, and third electrical connectors are plug-in connectors.

In one embodiment, the distributing unit comprises a vehicle electrical connector adapted to connect to the electric vehicle. The vehicle electrical connector may be fixedly secured to a connector receiving portion of the distributing unit. In
30 another embodiment, the charging station further comprises a flexible cable electrically connecting the vehicle electrical connector to the distributing unit and

the distributing unit further comprises a connector receiving portion for holding the vehicle electrical connector thereon. In this case, the frame may further comprise a cable receiving portion for receiving the flexible cable. In one embodiment, the charging station comprises a retracting mechanism for
5 retracting the flexible cable in the cable receiving portion. The flexible cable may be provided with a handle.

In one embodiment, the modular charging station comprises a position sensor operatively connected to the control unit and adapted for determining whether the vehicle electrical connector is positioned on the connector receiving portion. The
10 processing unit of the control unit is configured for terminating a transaction only if the position sensor detects that the vehicle electrical connector is positioned on the connector receiving portion.

In one embodiment, the frame comprises a further receiving portion for removably receiving the distributing unit therein, the distributing being directly and
15 removably secured to the frame.

In one embodiment, the control unit comprises an identification module for identifying a user and powering the energy providing means upon successful identification of the user.

In one embodiment, the modular charging station comprises a communication
20 unit for remote communication.

In one embodiment, the control unit comprises an electricity meter for measuring an amount of electrical energy consumed during the charge of the vehicle.

The modularity of the charging station may help reducing down time of the whole system since a defective modular component may be easily replaced and
25 repaired at a later time and/or at another location without disrupting the operating of the whole system, which may be of great advantage.

In one embodiment, the charging station is adapted for use in harsh climatic conditions, which may be of great advantage.

Thanks to its modularity, the charging station may be tailored according to specific needs of the given location, which may be of great advantage.

BRIEF DESCRIPTION OF THE DRAWINGS

In order that the invention may be readily understood, embodiments of the invention are illustrated by way of example in the accompanying drawings.

Figure 1 is a front view of a modular charging station, according to one embodiment.

Figure 2 is a side view of the modular charging station shown in Figure 1.

Figure 3 is a front view of a wall mount or pole mount modular charging station, according to another embodiment.

Figure 4 is another front view of the modular charging station shown in Figure 1.

Figure 5 is a cross sectional side view of the modular charging station shown in Figure 4, taken along lines C-C.

Figure 6A is an exploded front perspective view of a charging station comprising a control unit wiredly connected to a source of electrical energy, in accordance with an embodiment.

Figure 6B is an exploded front perspective view of a charging station comprising a control unit having a connector for connection to a source of electrical energy, in accordance with an embodiment.

Figure 7 is an exploded front perspective view of a portion of the charging station shown in Figure 1.

Figure 8 is a front perspective view of another portion of the charging station shown in Figure 1.

Figure 9 is a front view of another modular charging station, according to another embodiment.

Figure 10 is a top view of the modular charging station shown in Figure 9.

Figure 11 is a front view of another modular charging station, according to another embodiment.

Figure 12 is a front perspective view of the modular charging station shown in Figure 11.

5 Figure 13 is a top view of the modular charging station shown in Figure 11.

Figure 14 is a perspective view of a connector of a modular charging station usable for connecting to an electric vehicle, according to one embodiment.

Figure 15A is a block diagram of a modular charging station, according to one embodiment.

10 Figure 15B illustrates the connection between the block elements of Figure 15A.

Figures 16A to 16C show another embodiment of a modular charging station.

Figure 17 shows still another embodiment of a modular charging station.

Figure 18 shows yet another embodiment of a modular charging station.

15 Further details of the invention and its advantages will be apparent from the detailed description included below.

DETAILED DESCRIPTION

In the following description of the embodiments, references to the accompanying drawings are by way of illustration of an example by which the invention may be practiced. It will be understood that other embodiments may be made without
20 departing from the scope of the invention disclosed.

There is disclosed a charging station for electricity dispensing which is of a modular construction. The modularity of the charging station may help reducing down time of the whole system since a defective modular component may be easily replaced and repaired at a later time and/or at another location without
25 disrupting the operating of the whole system, which may be of great advantage, as detailed below.

Moreover, thanks to its modularity, the charging station may be tailored according to specific needs of the given location at which it is installed, for example for enabling electricity distribution to several different users at the same time with a single frame, as it will become apparent below.

- 5 The modularity of the charging station may help cutting down production costs. Indeed, the charging station is designed so that several elements may be interchanged with different types of the same element. This may be of great advantage when the charging stations are to be used in various countries having different electrical networks since different controls and/or standard connectors
10 may be implemented without having to redesign the whole charging station.

The modularity of the charging station may also help keeping the operating costs low. Indeed, if an update should be made to the charging stations, only the concerned element may be changed, without requiring an expensive change of the whole stations for new ones.

- 15 In one embodiment, the charging station is adapted for use in harsh climatic conditions, such as winter in northern countries such as Canada. As it will become apparent below upon reading of the present description, the construction of the charging station is devised to resist to heavy conditions such as snow, ice, cold and most of debris, while offering an easy and convenient experience to the
20 user.

- Referring to Figure 1, there is shown a modular charging station **10** for providing electrical energy at a given location. The modular charging station **10** may be used in a private space, such as at the residence of the user, or may also be used as a public charging station. In this latter case, the user may approach his
25 electric car proximate the charging station as he would do with a conventional gasoline pump, present a credit card to the station or otherwise arrange for payment, operatively connect the vehicle to the charging station and in turn be provided with electricity.

- The charging station may provide either standard line voltage of sufficient current
30 to charge the batteries, or a particular voltage power necessary for the charging. After the vehicle is charged, the amount of power provided may be calculated,

and either the credit card debited for the correct amount, or other arrangements to pay for the service may be accommodated such as debiting a prepaid account, as known in the art.

5 In the case of a private or semi-private dispensing station, several users may share the same station as subscribers, and may identify themselves to the station by key access with password, by card swipe, or by presenting a card containing an RFID chip that contains their identity. Service provided could then be billed to a prepaid or subscriber account.

10 Referring to Figures 1 and 2, the modular charging station **10** comprises a base **12** for anchoring the charging station **10** at the given location and a frame **14** attachable to the base **12**. In the illustrated embodiment, the base **12** is adapted for lying on the ground or to be attached on a horizontal receiving surface for providing a floor mount configuration.

15 Referring to Figure 3, there is shown another embodiment of a modular charging station **300** which is adapted for a wall mount configuration. Such configuration may be particularly advantageous for a private use since it may help providing a more compact charging station. In this case, the base (not shown) may be adapted for being attached to a vertical wall (not shown) while the frame **314** is attachable to the base.

20 In one embodiment, the base **12** may be omitted so that the frame would be directly secured to the floor, the vertical wall, or any other adequate receiving surface.

The modular charging station **300** shown in Figure 3 may also be mounted on a pole (not shown), as it should become apparent to the skilled addressee.

25 As illustrated in Figures 6A and 6B, the modular charging station **10** comprises a control unit **30** and a distributing unit **50** which are each removably secured to the frame **14** of the modular charging station **10**. The control unit **30** is adapted to control the electrical power provided to a user's vehicle and the distributing unit **50** is adapted to electrically connect to a battery or a charger of the vehicle for
30 charging the battery, i.e. for providing electrical energy to the vehicle. The control

unit **30** is electrically connected to a source of electrical energy such as an electrical grid for example, and the distributing unit **50** is electrically connected to the control unit **30** for receiving electrical energy therefrom and providing the received electrical energy to the vehicle to be charged.

5 Referring to Figures 7 and 8, in one embodiment, the base **12** comprises a plate disposed horizontally. In one embodiment, the base **12** is secured to the floor with fasteners (not shown) in order to prevent removal or theft of the charging station **10**. In one embodiment, the base **12** comprises an aperture (not shown) therethrough for receiving an electrical cable connected to the power grid or an
10 electric source, as it will become apparent below.

In one embodiment, as illustrated, the frame **14** comprises an elongated V-shaped extrusion **16**. In this embodiment, the frame **14** also comprises a connecting plate **18** (shown in Figure 7) secured to the extrusion **16** and adapted for attachment on the base **12**. In the illustrated embodiment, screws and bolts
15 **20**, **22** are used for attaching the frame **14** to the base **12** but the skilled addressee will appreciate that various others arrangements may be alternatively used.

It should be understood that the frame **14** may have any adequate shape which allows the control unit **30** and the distributing unit **50** to be removably secured
20 thereto. For example, the frame **14** may have a substantially U-shape, a substantially half-circular shape, or the like.

Referring again to Figure 6A and in accordance with one embodiment, the modular charging station **10** comprises an electrical connection **24** having a first end **26** operatively connectable to a source of electrical energy such as an
25 electrical grid or a source of renewable energy for example, and a second end **28** connected to the control unit **50**. In one embodiment, the first end **26** of the electrical connection **24** is connected to the power grid only in order to dispense energy available through the power grid. In another embodiment, the first end **26** of the electrical connection **24** may be connected to a renewable source only. It
30 may be of great advantage for dispensing electrical energy to vehicles in remote or distant areas where the power grid cannot be easily accessed or is just not

available. In a further embodiment, the first end **26** of the electrical connection **24** may be connected to both the power grid and a renewable energy source, as it should be apparent to the skilled addressee.

In another embodiment, the control unit **50** is provided with an electrical
5 connector **35**, such as a plug-in or snap electrical connector for example, to be electrically connected to the source of electrical energy, as illustrated in Figure 6B.

In one embodiment, as illustrated in Figures 7 and 8, electrical connectors **8**, **9**,
and **9'** are used for electrically connecting the control unit **30** to the source of
10 electrical energy. In one embodiment, the electrical connector **9'** is adapted to be connected to the end **26** of the electrical connection **24**. In another embodiment, the electrical connector **9'** is adapted to be connected to the connector **35** of the control unit **30** for powering both the control unit **30** and the distributing unit **50**. In this case, the connector **9'** may be a plug-in or snap connector mating the
15 connector **35**, for example.

The electrical connector **9'** is electrically connected to the electrical connectors **8**
and **9**. The connector **8** is electrically connected to the source of electrical energy
while the connector **9** is grounded. For example, the connector **9** may be
connected to a power panel so as to be grounded. The connectors **8**, **9**, and **9'**
20 may be located in a recess portion of the frame **14** located in a lower portion thereof.

This may be of great advantage for reducing installation and maintenance costs.
Indeed, at the initial installation, a certified electrician may be required to connect
the electrical connector **8** to the source of electrical energy, the connector **9** to the
25 ground, and the electrical connectors **8** and **9** to the electrical connector **9'**. Then, a technician may finalize the installation in electrically connecting the control unit **30** to the connector **9'**, i.e. electrically connecting the connectors **35** and **9'** together. If it has to be replaced, the control unit **30** is simply removed from the frame **14** and the connectors **35** and **9'** are disconnected from one another.

30 In another embodiment, an electrical junction box is used for providing an electrical connection between the charging station and the power grid. The

junction box may be placed between the electrical connection **24** or the connector **35** and the source of electrical energy so as to be electrically connected to the source of electrical energy. In one embodiment, the junction box is mounted in the frame **14**, in a lower portion thereof. This may be of great advantage for
5 reducing installation and maintenance costs. Indeed, at the initial installation, a certified electrician may be required to install the junction box and effect the electrical connection between the power grid and the charging station. Then, a technician may finalize the installation in connecting the electronics of the charging station **10** to the junction box.

10 Referring to Figures 1, 6A, and 6B and as described above, the modular charging station **10** comprises a control unit **30** comprising a memory and a processing unit configured for selectively controlling access to the electrical energy, as it will become apparent below. The control unit **30** is removably attached to the frame **14** and has a receiving cavity **32** therein for receiving the distributing unit **50**.

15 In one embodiment, the control unit **30** comprises a switch for selectively powering the distributing unit **50**. The switch is controlled by the processing unit of the control unit **30**. In one embodiment, upon determination that the user is permitted to use the charging station, the processing unit of the control unit **30** turns the switch on to power the distributing unit **50**.

20 In one embodiment, the control unit **30** has a shape matching that of the frame **14** or a receiving portion of the frame **14** so as to be inserted in the frame **14**. In the illustrated embodiment, the control unit **30** has a back face **34** which is V-shaped in order to be mountable in the frame **14**. In this case, the elongated frame **14** may be provided with an upper receiving portion **36** adapted for receiving the
25 back face **34** of the control unit **30** in a snugly relationship. The upper receiving portion **36** adapted for receiving the back face **34** may be provided, in one embodiment, with outer lips or rails **38**, **40** devised to hold the control unit **30** in position and removably secure the control unit **30** to the frame **14**.

30 In the same or another embodiment, cooperating fasteners **42**, **44** may be provided on both the control unit **30** and the frame **14** for releasably securing the control unit **30** to the frame **14** and preventing an unwanted removal thereof. In

still a further embodiment, a special tool may be required for removing the control unit **30** from the frame **14**, as known in the art. For example, the fasteners may be torque nuts having an unusual head shape and the special tool may be a screwdriver adapted to the unusual shape of the torque nut head. The skilled addressee will however appreciate that various other arrangements for removably securing the control unit **30** to the frame **14** may be considered.

In one embodiment, the upper portion **36** of the frame **14** may be made flexible for enabling snapping the control unit **30** in place. In this case, the control unit **30**, thanks to its beveled back face **34**, may be forced inside the upper portion **36** which flex outwardly. Once the control unit **30** in place, the sides **46**, **48** of the upper portion **36** will return to their natural positions to thereby hold the control unit **30** in place and removably secure the control unit **30** to the frame **14**.

In another embodiment, the control unit **30** may be slid vertically into the upper portion **36** of the frame **14** and removably held in position with fasteners, as it should become apparent to the skilled addressee. During the insertion of the control unit **30** in the receiving portion **36**, the lips **38**, **40** guide the control unit **30** in the receiving portion **36** in addition to hold the control unit **30** in the receiving portion **36**. In one embodiment, the upper portion **34** of the frame **14** may be shaped with at least one lower abutting member. In this case, the control unit **30** may be slid into the frame **14** until it abuts on the abutting member.

In one embodiment, the base **12** may be made from a rigid metallic material such as aluminum. In another embodiment, the frame **14** may be made from metallic or plastic material. In a further embodiment, the control unit **30** is embedded in an outer casing made from metallic or plastic material. The skilled addressee will nevertheless appreciate that other materials and combination thereof may be considered.

In one embodiment wherein the charging station is a public one, it may be advantageous that the station be made robust. In this case, metallic material such as aluminum may be preferred. In another embodiment wherein the station is a private one, plastic may be used for reducing manufacturing costs. The

skilled addressee will nevertheless appreciate that various other materials may be used for various parts of the described charging station.

Still referring to Figures 1 and 6 and as described above, the modular charging station **10** comprises a distributing unit **50** mountable in the receiving cavity **32** of the control unit **30**.

In one embodiment, the back face **52** and the side faces **54**, **56** of the distributing unit **50** as well as the back face **58** and the side faces **60**, **62** of the receiving cavity **32** of the control unit **30** are shaped to cooperate together in order to receive the distributing unit **50** in a snugly relationship. In one embodiment, the distributing unit **50** may be snapped into the receiving cavity **32** of the control unit **30**.

It should be understood that any adequate method for electrically connecting the control unit **30** and the distributing unit **50** together may be used. For example, an electrical cable may removably connect the distributing unit **50** to the control unit **30** in order to receive electrical energy and charge the battery of a vehicle. In another example, the control unit **30** and the distributing unit **50** may be provided with mating connectors such as snap connectors. Referring to Figure 6, the control unit **30** is provided with an electrical connector **53** on the back face **58** of the receiving cavity **32**, and the distributing unit **50** is provided with a mating electrical connector **51** on its back face **52**. The electrical connectors **51** and **53** are positioned to face each other during the insertion of the distributing unit **50** into the receiving cavity **32** of the control unit **30** so that, when the distributing unit **50** is inserted in the receiving cavity **32**, the electrical connectors **51** and **53** removably connect together for removably and electrically connecting the distributing unit **50** to the control unit **30** and no electrical cable is required.

In one embodiment, fasteners (not shown) may be used for securing the distributing unit **50** in the receiving cavity **32** and thereby preventing an unwanted removal thereof. In still a further embodiment, a special tool, such as the one described above, may be required for removing the distributing unit **50** from the control unit **30**, as known in the art. The skilled addressee will however

appreciate that various other arrangements for securing the distributing unit **50** in the control unit **30** may be considered.

While in the above described embodiment, the distributing unit **50** is removably secured to the frame **14** of the modular charging station via the control unit, i.e. the control unit **30** comprises a receiving cavity **32** for removably receiving the distributing unit **50** therein, it should be understood that other adequate configurations are possible. For example, the frame **14** may be provided with a first receiving portion and a second receiving portion adjacent together for respectively receiving the control unit **30** and the distributing unit **50**. The receiving portions may each be a separate cavity in the frame **14**.

Referring to Figures 4, 5 and 6, the distributing unit **50** has an energy providing means **64** operatively connected to the second end **28** of the electrical connection **24** and is adapted for selectively providing the electrical energy to a battery powered device such as a vehicle in the described example. The energy providing means **64** is adapted to connect to a battery or a charger of the vehicle to be charged.

Indeed, the control unit **30** which is operatively connected to the distributing unit **50** controls access to the electrical energy in selectively enabling and preventing distribution of electrical energy, i.e. selectively powering the energy providing means **64**. In one embodiment, the control unit **30** is adapted to identify the vehicle or the user of the vehicle as well known in the art to thereby provide energy through the electrical connector **64**, as detailed below.

Referring to Figures 1, 5 and 14 and in accordance with one embodiment, the energy providing means **64** comprises a flexible electrically conductive cable **66** having a first end **68** operatively connected to the electrical connector **51** and a second end **70** provided with a connector **72** adapted for operatively connecting with a corresponding connector (not shown) provided on the battery or charger of the electrical vehicle to be charged.

Referring to Figure 17, in one embodiment, the flexible conductive cable **66** is firmly attached proximate its first end **68** to the distributing unit **50** or the control unit **30**. In one embodiment, the frame **14** comprises a lower cable receiving

portion **51** which is adapted to receive and protect the cable **66** when not in use. It is worth mentioning that various other configurations may be envisaged for a given application.

In a further embodiment, as shown in Figure 18, the flexible conductive cable **66** is retractably mounted with respect to the frame **14**. This may help returning the conductive cable **66** in its initial position after use. Indeed, after use, the user will replace the connector **72** in the receiving portion **74** of the distributing unit **50**, as detailed below. The control unit **30** may detect that the user has finished his charging session and may operate a retracting mechanism **94** adapted for retracting the conductive cable **66** in the receiving portion **51**.

In one embodiment, the retracting mechanism **94** comprises a motor **96** fixedly mounted to the frame **14** and a roller **98** driven by the motor **96**. The retracting mechanism **94** further comprises a retracting cable **100**, a steel cable for example, having a first end **102** connected to the roller **98** and a second end **104** attached to the conductive cable **66**. In one embodiment and as illustrated, the retracting cable **100** may be attached to a middle portion of the conductive cable **66** although various other arrangements may be considered.

In one embodiment, the conductive cable **66** has a shape similar to a phone cable handset, although any other cable adapted for conducting the electrical energy may be used, as apparent to the skilled addressee. The retracting cable **100** may be mounted inside the conductive cable **66** in this embodiment.

Referring to Figures 5, 6A, and 6B, in one embodiment, the distributing unit **50** has a receiving portion **74** on its front face for receiving and holding the connector **72**. The skilled addressee will nevertheless appreciate that various alternative configurations may be envisaged for holding the connector **72**.

In one embodiment, the connector **72** comprises a SAE J1772 connector adapted for use in North America. In another embodiment, the connector **72** comprises a VDE-AR-E 2623-2-2 connector adapted for use in Europe. The skilled addressee will nevertheless appreciate that various other connectors may be used, provided it enables an operative connection between the charging station and the vehicle.

In one embodiment, the flexible conductive cable **66** comprises an aluminum conductor covered with a protective layer. Copper or any other suitable material may be used for the conductor. However, an aluminum conductor may be advantageous since it has suitable conductive properties while being much less
5 expensive than an equivalent copper conductive cable. This may help discouraging theft and vandalism of the charging station, which is of great advantage.

Referring to Figure 17, in one embodiment, the flexible conductive cable **66** comprises a handle **76** mounted proximate the connector **72** in order to provide
10 an easy grip to the user. In a further embodiment, an additional handle **78** may also be provided on the cable **66** distal from the first handle **76** to further enhance manipulation of the cable **66**.

In one embodiment, the distributing unit **50** may be provided with a position sensor (not shown) adapted for sensing presence and/or absence of the
15 connector **72** in the corresponding receiving portion **74** thereof. This may encourage users to correctly replace the connector **72** in the receiving portion **74** after use. The control unit **30** may be adapted to terminate the transaction only if the position sensor detects that the connector **72** is positioned back in the receiving portion **74**. The control unit may also be adapted to provide a visual or
20 sound signal to the user indicating that the connector has not been replaced in the receiving portion **74**. For example, the position sensor may be an optical position sensor, a mechanical position sensor, or the like. Indeed, the skilled addressee will appreciate that the identified user may be informed or even punished for failure to doing so. Other means adapted for detecting the presence
25 of the connector **72** in the receiving portion **74** may be considered, as apparent to the skilled addressee.

In the case where the charging station **10** is used in harsh climatic conditions, this may enhance comfort of the users since the connector **72** should always be in its receiving portion **74** instead of running on the floor, in ice or snow for instance.
30 Moreover, in such conditions, ensuring the connector **72** is not on the floor may also help reducing breaks caused by motorized snow removal.

In another embodiment, the energy providing means **64** does not comprise a flexible conductive cable **66**. Instead, the energy providing means **64** comprises an electrical connector (not shown) such as a plug for example mounted to the distributing unit **50**. In this case, the user may use his own electrical cable to
5 connect the batteries of the vehicle to the plug of the distributing unit **50**, as apparent to the skilled addressee.

Referring to Figures 1 and 2, in one embodiment, the charging station **10** comprises a communication unit **80** mounted on the top of the control unit **30** or on the top of the frame **14**. The communication unit **80** may comprise an antenna
10 for enabling RF communication between the charging station **10** and the vehicle or a portable identification device for example. In a further embodiment, the communication unit **80** may enable a wireless communication over a network with a remote central control station operating a set of charging stations, as known to the skilled addressee. In one embodiment, the communication unit **80** may be
15 used for updating the embedded software stored in a memory and executed by the processing unit of the control unit **30** of the charging station **10**.

In one embodiment, the modular charging station **10** comprises an electricity meter for measuring the amount of electrical energy consumed during a charge of a vehicle. The electricity meter is operatively connected to the control unit **30**
20 which receives the amount of consumed energy for invoicing the user.

In one embodiment, the control unit **30** comprises a user interface mounted on its front face. The user interface may comprise a display for displaying various information to the user, such as instructions for operating the charging station, the cost of the battery recharge, and the like, as well as a set of light-emitting
25 diodes (LEDs) used for providing visual indications such as the state of the charging station **10** for example.

In one embodiment, the control unit **30** comprises a credit card reader operatively connected to the processing unit. The information about the user's credit card is provided by the credit card reader to the control unit **30** which transmits the credit
30 card information to a remote server via the communication unit **80**. The remote server validates the credit card information and returns a validation signal to the

control unit **30**. Upon reception of the validation signal, the processing unit powers the energy providing means **64**.

In a further embodiment, the control unit **30** comprises an identification means for identifying the user and powering the energy providing means **64** following a
5 successful identification of the user.

For example, a user may have to preregister before using the charging station **10** and is provided with an identification (ID). The ID may be a barcode, a radio-frequency identification (RFID) tag, a password, a conventional credit card, or the like. The control unit **30** comprises an adequate ID input device adapted to
10 receive the user ID. For example, the ID input device may be a keyboard that may be used by the user to enter his password. In another example, the ID input device may be a barcode reader. In a further example, the ID input device may be an RFID tag reader.

The ID input device receives the user ID and transmits it to the processing unit of
15 the control unit **30**. In one embodiment, a list of authorized users is stored on the memory of the control unit **30**. The processing unit compares the user ID received from the ID input device to the stored list of authorized users to verify the user identity. Upon successful verification, the control unit **30** powers the energy providing means **64**. In another embodiment, the verification may be
20 remotely performed on a server. In this case, the control unit **30** sends, via the communication unit **80**, the user ID to a remote server which verifies the user identity. Upon reception of a signal indicative of a successful verification from the remote server, the control unit **30** powers the energy providing means **64**.

In one embodiment, the communication unit **80** may comprise a plastic casing
25 fixedly mounted on the top of the frame **14** for enabling a suitable transmission of RF signals therethrough, although other arrangements may be considered.

The skilled addressee will appreciate that the electronics is embedded in the control unit **30** and in the distributing unit **50**. This may be of great advantage from a maintenance point of view since the control unit **30** and the distributing
30 unit **50** may be easily replaced with similar components. Moreover, once the charging station has been initially installed, typically with the help of a certified

electrician, the control unit **30** and the distributing unit **50** may be replaced by technicians, thereby reducing the maintenance costs associated with the operation of the charging station.

Referring to Figures 9 and 10, in one embodiment, the frame **14** comprises two adjacent extrusions **82, 84**, each receiving a corresponding control unit **30** and a corresponding distributing unit **50**.

In Figures 11 to 13, the frame comprises four adjacent elongated extrusions **86, 88, 90, 92** mounted perpendicularly to each other. This configuration may provide four different users at the same time with four distinct points of charge with a single connection to the power grid.

Referring to Figures 16A to 16C, in one embodiment, the charging station **500** may be provided with a hinged door **502** operatively connected to the frame **514** for protecting the connector **72** and the conductive cable **66** from surroundings when the charging station is not in used.

Figures 15A and 15B illustrate one embodiment of the cooperation and connection between the control unit **30** and the distributing unit **50**. The control unit **30** comprises a power card **30a**, a control card **30b**, an electrical switch **31** such as a magnetic contactor switch for example, and two electrical connectors **35** and **53**. The electrical connector **35** is removably connected to the connector **9'** to receive the electrical energy for powering the components of the control unit **30** and the distributing unit **50**, and the vehicle to be recharged. The switch **31** is electrically connected to the connector **35** and the connector **53** to selectively power the connector **53**. The switch **31** is activated by the power card **30a**. The power card **30a** and the control card **30b** are connected together. When it determines that the distributing unit **50** has to be powered, the control card **30b** sends a first signal to the power card **30a** which turns on the switch **31** upon reception of the first signal. Similarly, when the control card **30b** sends a second signal indicative that the distributing unit **50** should not be powered to the power card **30a**, the power card **30a** turns off the switch **31**.

In one embodiment, the distributing unit **50** comprises a connector **51**, a door sensor for determining whether the door **502** is open or closed, a position sensor

for determining whether the connector **72** is positioned in its receiving portion, a lock sensor for determining whether the door **502** is locked, and a solenoid for activating a lock mechanism for locking the door **502**. The different sensors and the solenoid are electrically connected to the connector **51**. The distributing unit **50** further comprises a vehicle connector, such as connector **72** for example, electrically connected to the connector **51** via a cable such as cable **66**. The communication between the sensors and the solenoid, and the control card **30b** occurs via the connectors **51** and **53** so that the control card **30b** may control the powering of the vehicle connector and the locking mechanism solenoid of the door **502** as a function of the signals received from the different sensors. The powering of the sensors, the solenoid, and the vehicle connector also occurs through the connectors **51** and **53**. The connectors **51** and **53** form a door between the control unit **30** and the distributing unit **50**, through which all communication and powering signals pass.

15 In one embodiment, the control card **30b** is connected to an antenna for communicating to a remote server for example, and LEDs for informing a user of the charging station.

In one embodiment, the control unit **30** comprises two inductors, such as a Ground Fault Circuit Interrupter (GFCI) coil and a meter coil for example, positioned between the switch **31** and the connector **53**, and controlled by the power card **30a**. The vehicle connector is connected to the power card **30a** through the connectors **51** and **53** so that a signal for controlling the electrical energy provided to the vehicle may propagate from the vehicle connector to the power card. Upon reception of this control signal, the power card **30a** adjusts the electrical current provided to the vehicle via the two inductors.

The embodiments embodying several points of charge may be particularly advantageous for an operator of a group of a plurality of charging stations. Indeed, the costs associated with the installation of the charging stations may be greatly reduced while providing a suitable number of points of charge. Indeed, the connection to the power grid may be initially adapted for receiving four points of charge for example even if the frame is initially configured for receiving a single point of charge. When the operator decides to expand his business by increasing

the number of points of sale, the installation may be made by a technician without requiring a certified electrician since the frame may be changed for another frame adapted to provide a plurality of points of sale. The skilled addressee will appreciate that this is of great advantage. The control units 30 will be connected
5 to the power grid without expensive costs.

As it should become apparent to the skilled addressee, the modular design of the charging station is particularly advantageous since it enables a mass production of similar parts, while providing a charging station adapted for any country in the world. This may contribute to lower the manufacturing costs, which is of great
10 advantage. Moreover, as it should be understood upon reading of the present description, the number of parts required is minimized, thus reducing even more the costs associated to a charging station. Furthermore, the installation is simplified, thus also reducing installation and maintenance costs.

In one embodiment, the charging station may also be used to inject reverse flow
15 power back into the electric grid and receive credit for this, as known to the skilled addressee.

In another embodiment, dynamic electrical rates may be taken into account to minimize the cost of electricity or maximize the credit. In this case, the charging station may be adapted to communicate with a rate advisory service to provide a
20 current rate for electricity. In one embodiment, the user may cause the beginning of charging to be delayed until a certain rate is reached with optional override at a certain time if the chosen rate is not reached. This is especially attractive for charging at night where rates may drop later in the night due to less demand for electricity.

25 The skilled addressee will appreciate that in one embodiment, the described charging station is well adapted for used in harsh climatic conditions. Indeed, the frame, the control unit and the distributing unit are mounted together using snugly couplings between the elements. This may help preventing debris, sand and precipitation from accumulating inside the charging station. The
30 communication unit which is installed on the top of the frame for enhancing

communication may also be snugly mounted with the frame for preventing unwanted insertion of debris in the charging station.

Moreover, the position sensor is devised to encourage users to position the connector in its correct position after use. Furthermore, the cable **66** is retracted
5 inside the frame when not in use in one embodiment. This helps protecting the cable against precipitation which may otherwise soil the cable and then eventually the suit of the user.

Although the above description relates to specific preferred embodiments as presently contemplated by the inventors, it will be understood that the invention in
10 its broad aspect includes mechanical and functional equivalents of the elements described herein. Moreover, although the invention has been described in the particular field of electricity dispensing for electric or hybrid vehicles, it should be understood that the invention may be used in various other applications such as the charging of portable devices for a non-limitative example.

WHAT IS CLAIMED IS:

1. A modular charging station for charging an electric vehicle, the modular charging station comprising:
 - a frame having a receiving portion;
 - 5 a control unit removably secured to the receiving portion of the frame and electrically connectable to a source of electrical energy, the control unit for selectively controlling access to the electrical energy; and
 - a distributing unit removably secured to the frame, electrically connected to the control unit for receiving the electrical energy therefrom, and electrically
10 connectable to the electric vehicle for providing the electrical energy to the electric vehicle, a powering of the distributing unit being controlled by the control unit.
2. The modular charging station of claim 1, wherein the control unit
15 comprises a receiving cavity for removably receiving the distributing unit therein.
3. The modular charging station of claim 2, wherein a shape of a rear face of the control unit matches a shape of the receiving cavity for a snugly relationship between the control unit and the frame.
20
4. The modular charging station of claim 3, wherein the frame comprises an elongated V-shaped extrusion.
5. The modular charging station of any one of claims 2 to 4, wherein the
25 control unit comprises a switch for activating a powering of the distributing unit, a first electrical connector connected to the switch and connectable to the source of electrical energy, and a second electrical connector connected to the switch and the distributing unit.
- 30 6. The modular charging station of claim 5, wherein the distributing unit comprises a third electrical connector electrically connected to the second electrical connector for receiving the electrical energy therefrom.

7. The modular charging station of claim 6, wherein the first, second, and third electrical connectors each comprise a plug-in connector.

8. The modular charging station of any one of claims 1 to 7, wherein the distributing unit comprises a vehicle electrical connector adapted to connect to the electric vehicle.

9. The modular charging station of claim 8, wherein the vehicle electrical connector is fixedly secured to a connector receiving portion of the distributing unit.

10. The modular charging station of claim 8, further comprising a flexible cable electrically connecting the vehicle electrical connector to the distributing unit, the distributing unit further comprising a connector receiving portion for holding the vehicle electrical connector thereon.

11. The modular charging station of claim 10, wherein the frame further comprises a cable receiving portion for receiving the flexible cable.

12. The modular charging station of claim 11, further comprising a retracting mechanism for retracting the flexible cable in the cable receiving portion.

13. The modular charging station of any one of claims 10 to 12, further comprising a handle secured to the flexible cable.

14. The modular charging station of any one of claims 10 to 13, further comprising a position sensor operatively connected to the control unit, the position sensor for determining whether the vehicle electrical connector is positioned on the connector receiving portion.

15. The modular charging station of claim 14, wherein the processing unit of the control unit is configured for terminating a transaction only if the position sensor detects that the vehicle electrical connector is positioned on the connector receiving portion.

16. The modular charging station of claim 1, wherein the frame comprises a further receiving portion for removably receiving the distributing unit, the distributing being directly and removably to the frame.

5

17. The modular charging station of any one of claims 1 to 16, wherein the control unit comprises an identification module for identifying a user and powering the energy providing means upon successful identification of the user.

10 18. The modular charging station of any one of claims 1 to 17, further comprising a communication unit for remote communication.

15 19. The modular charging station of any one of claims 1 to 18, wherein the control unit comprises an electricity meter for measuring an amount of electrical energy consumed during the charging of the vehicle.

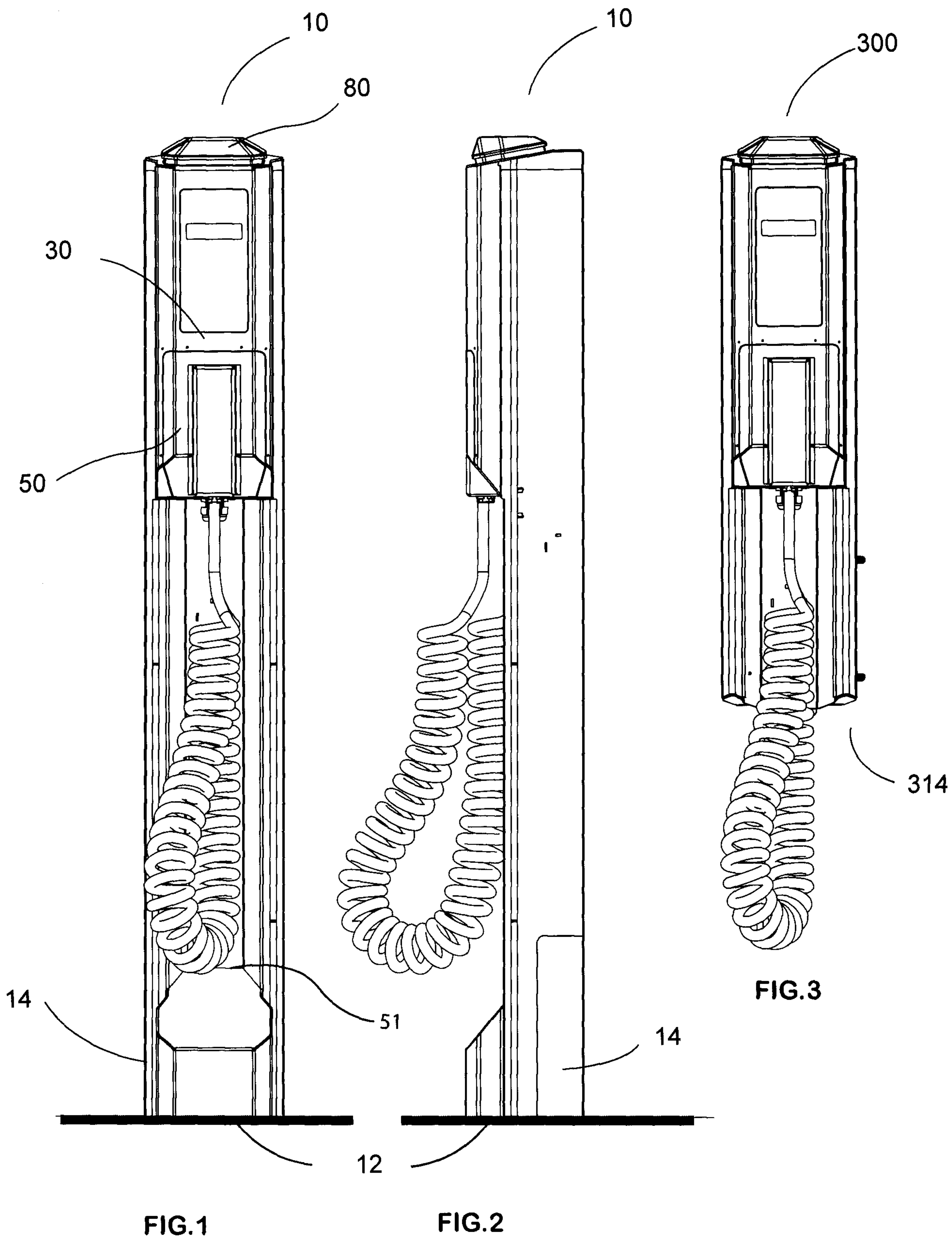

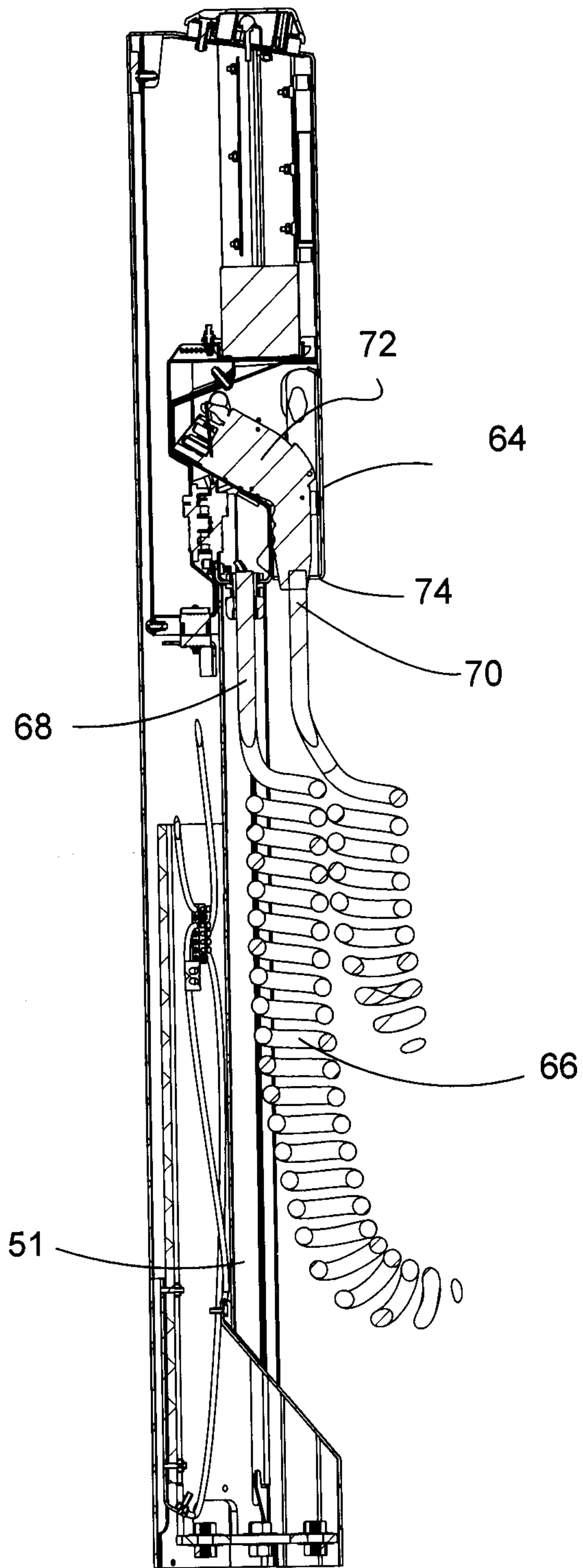

FIG.5

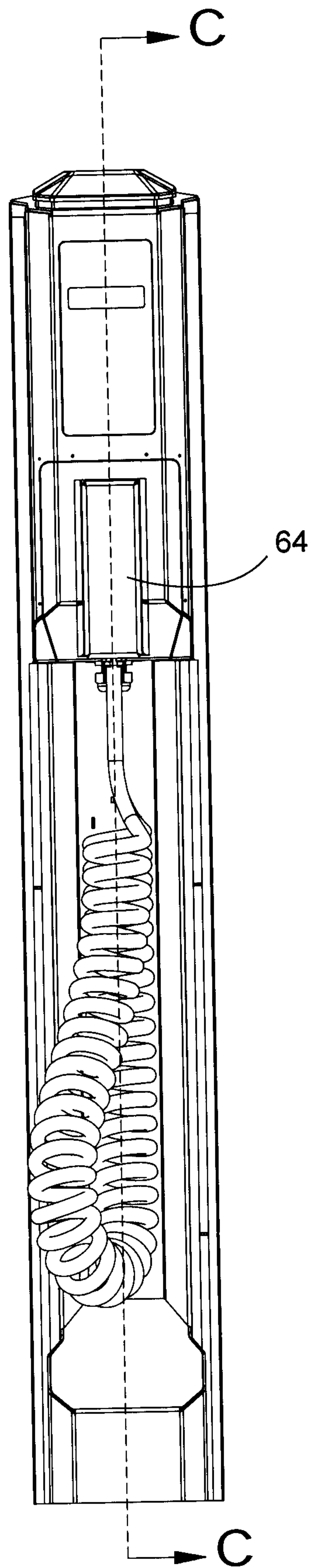

FIG.4

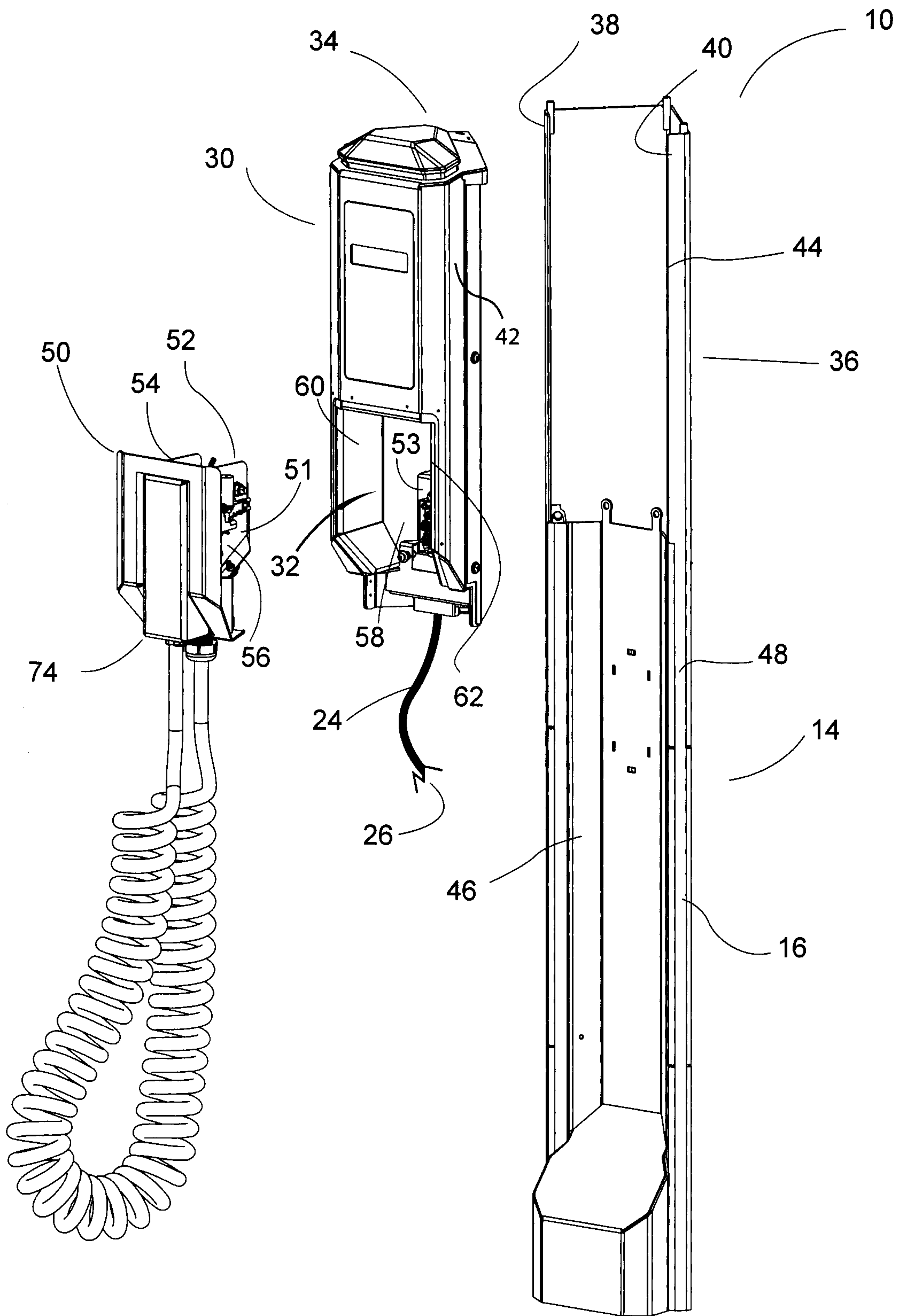

FIG. 6A

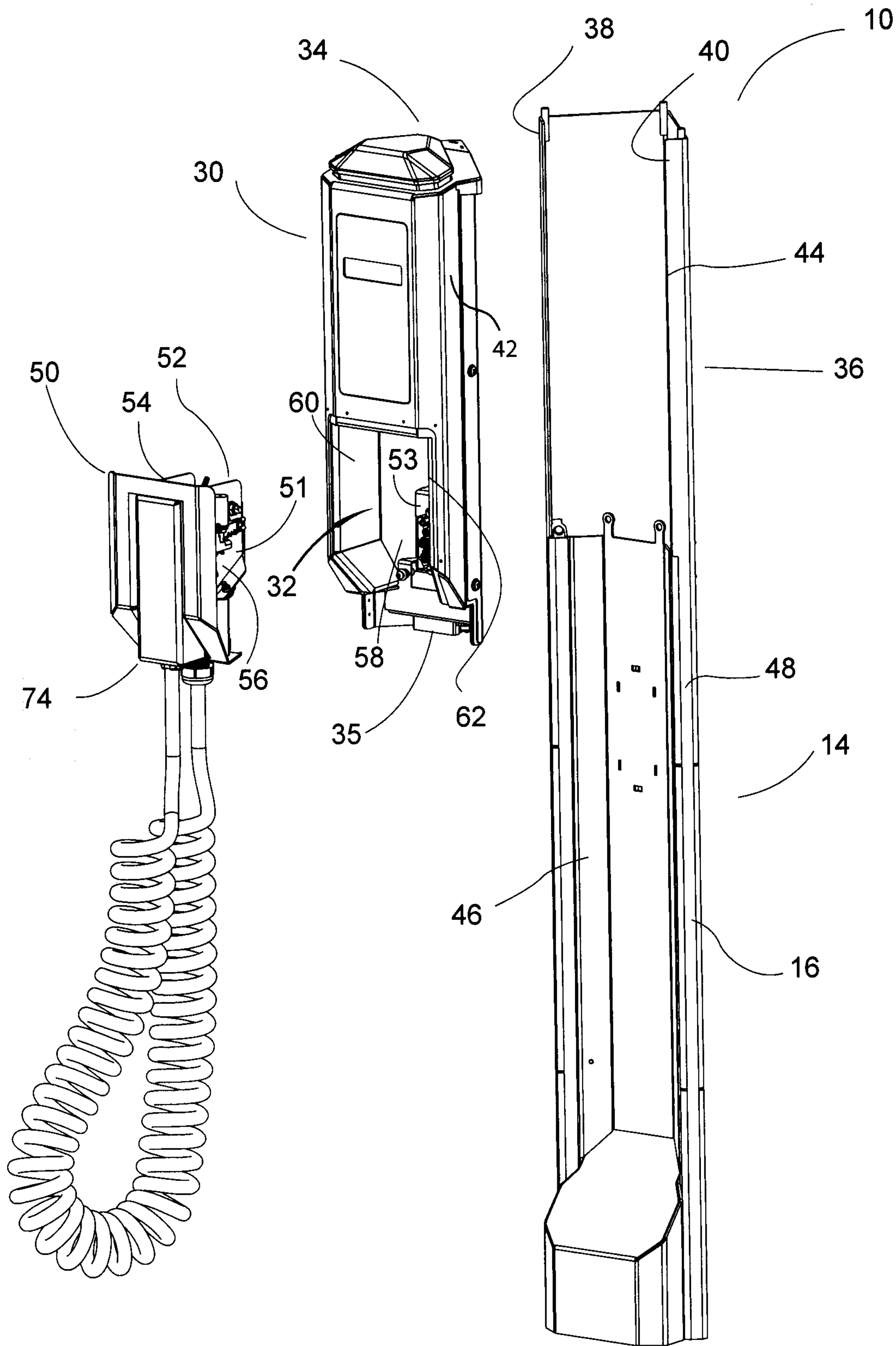

FIG. 6B

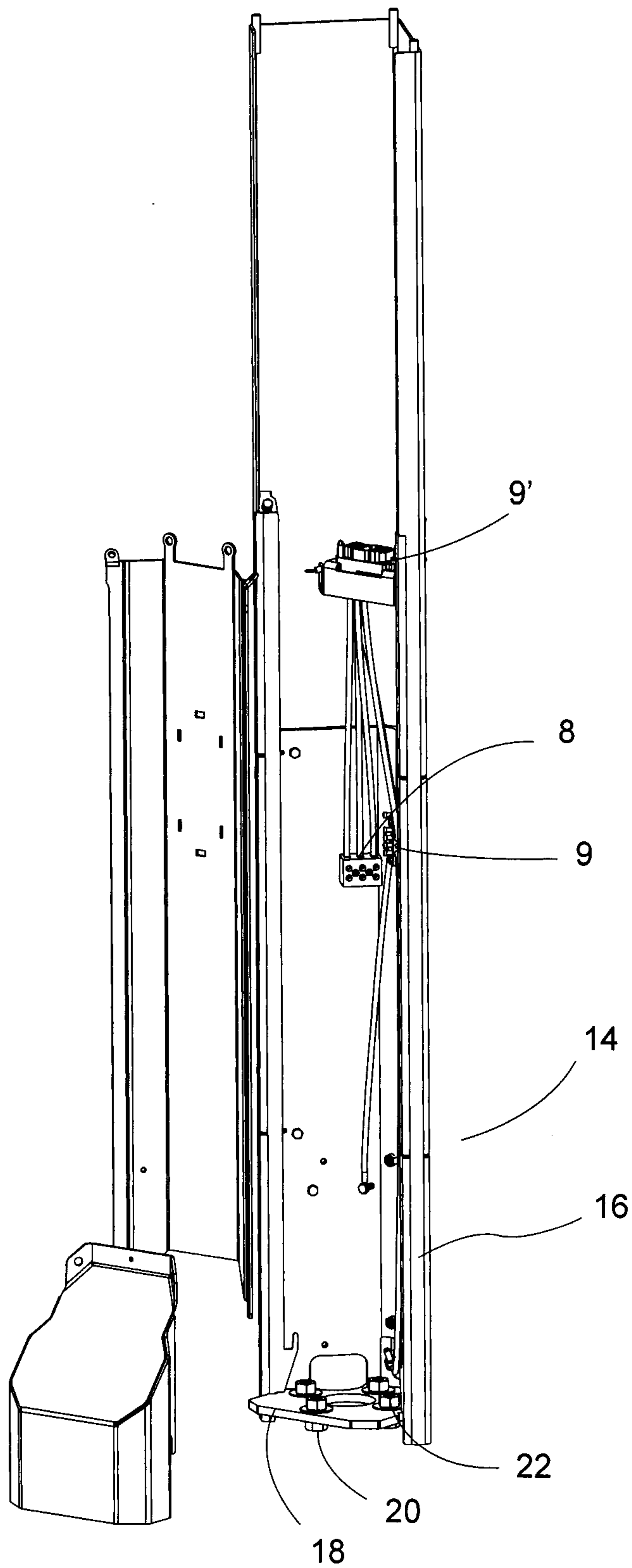

FIG. 7

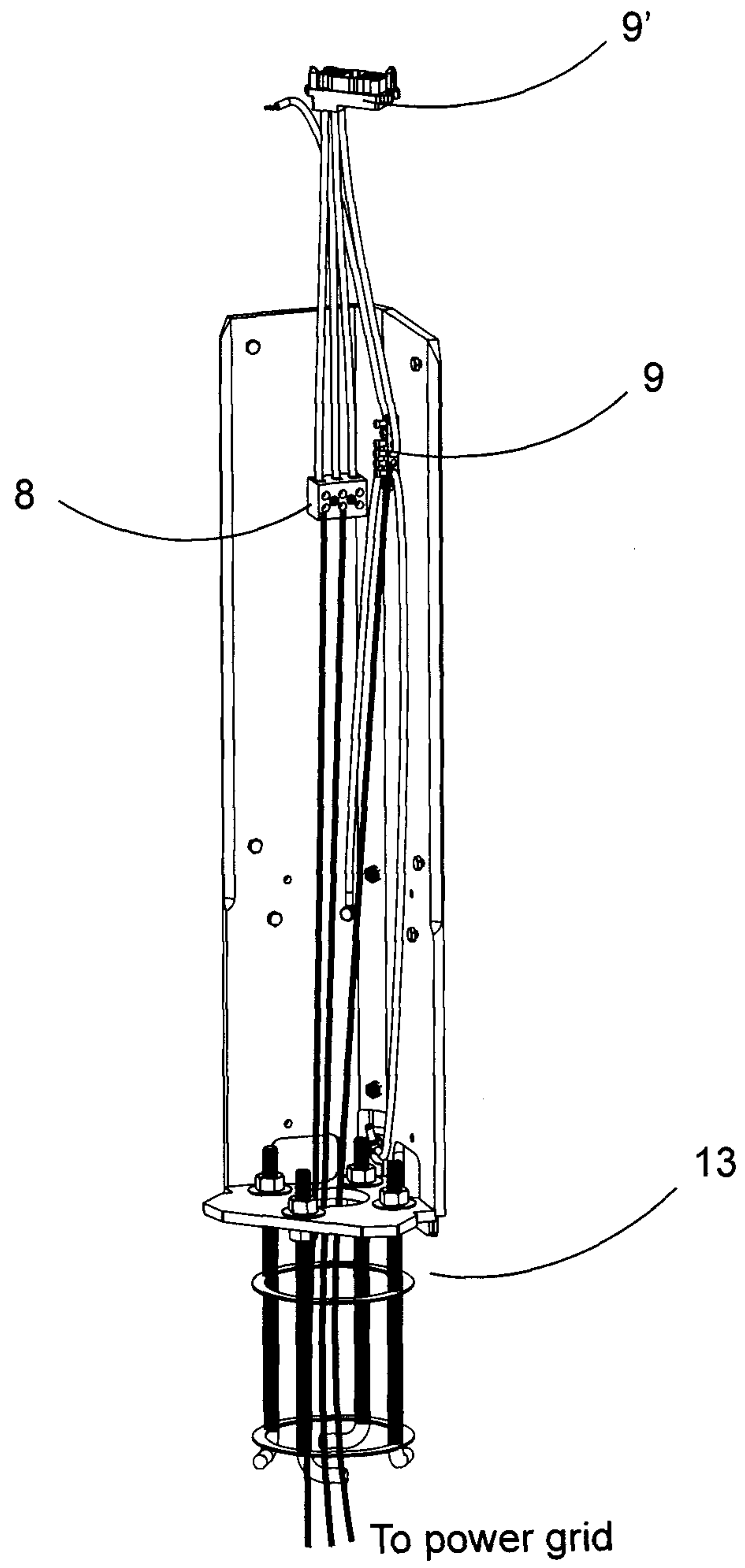

FIG. 8

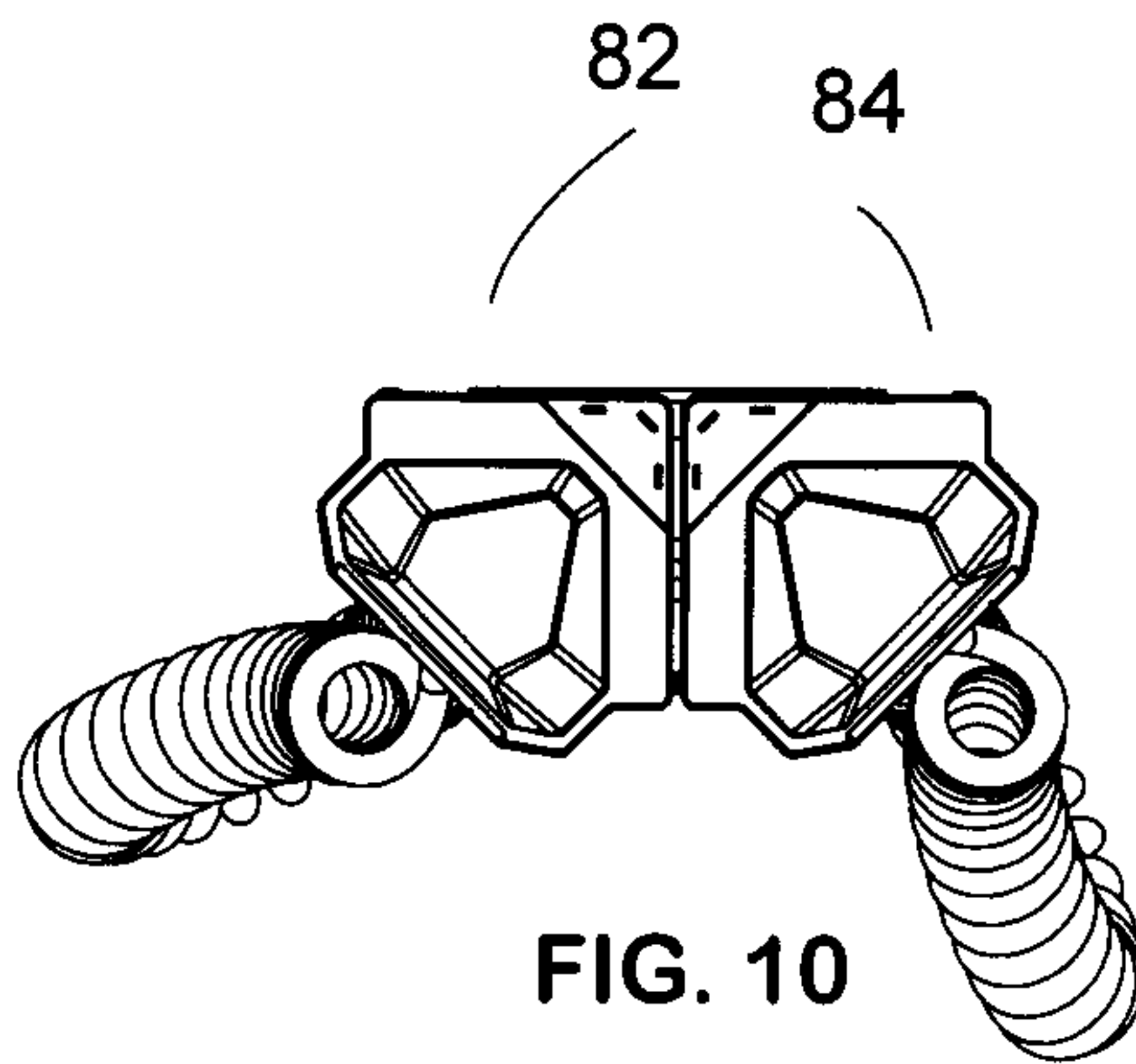

FIG. 10

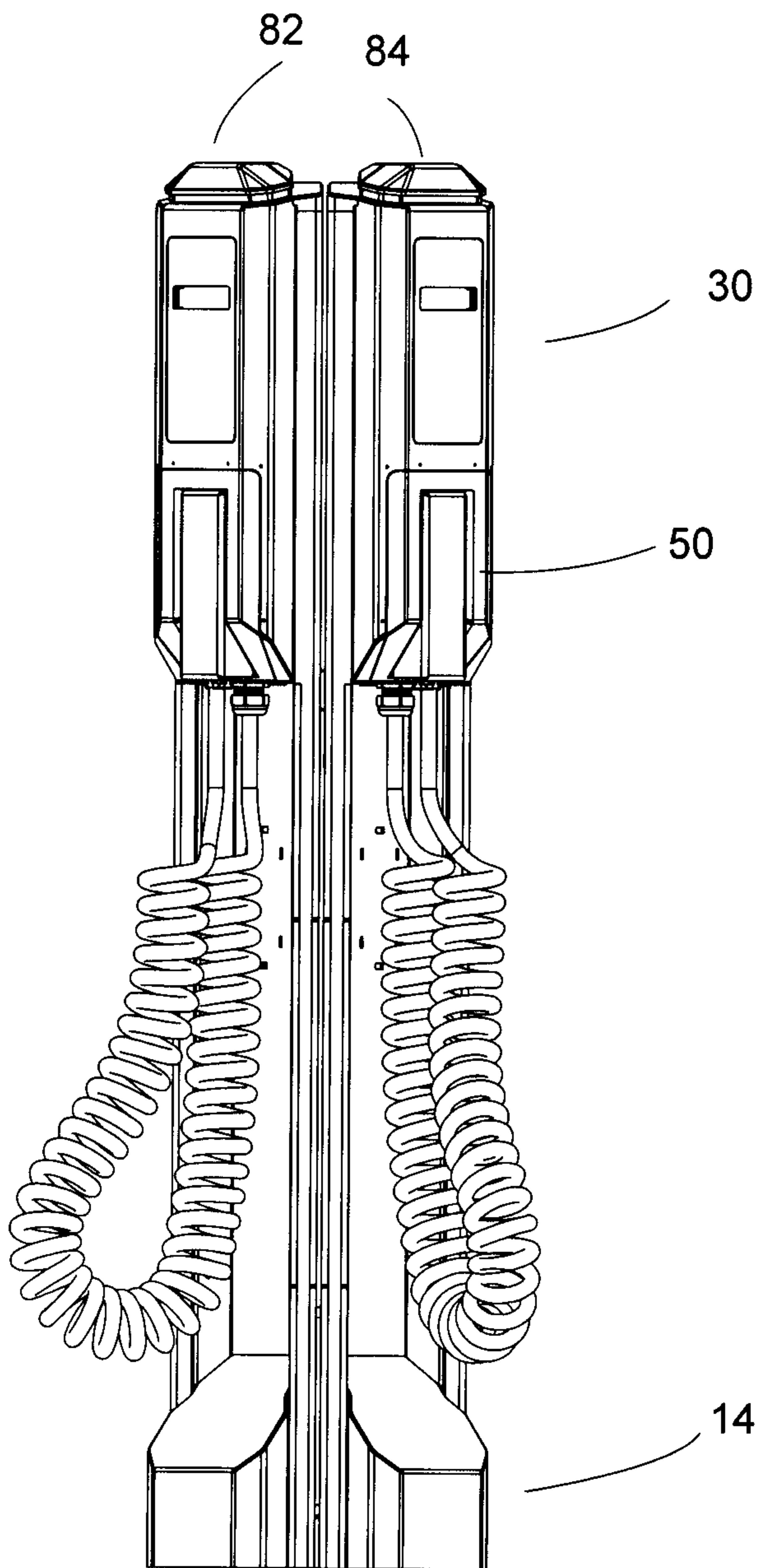

FIG. 9

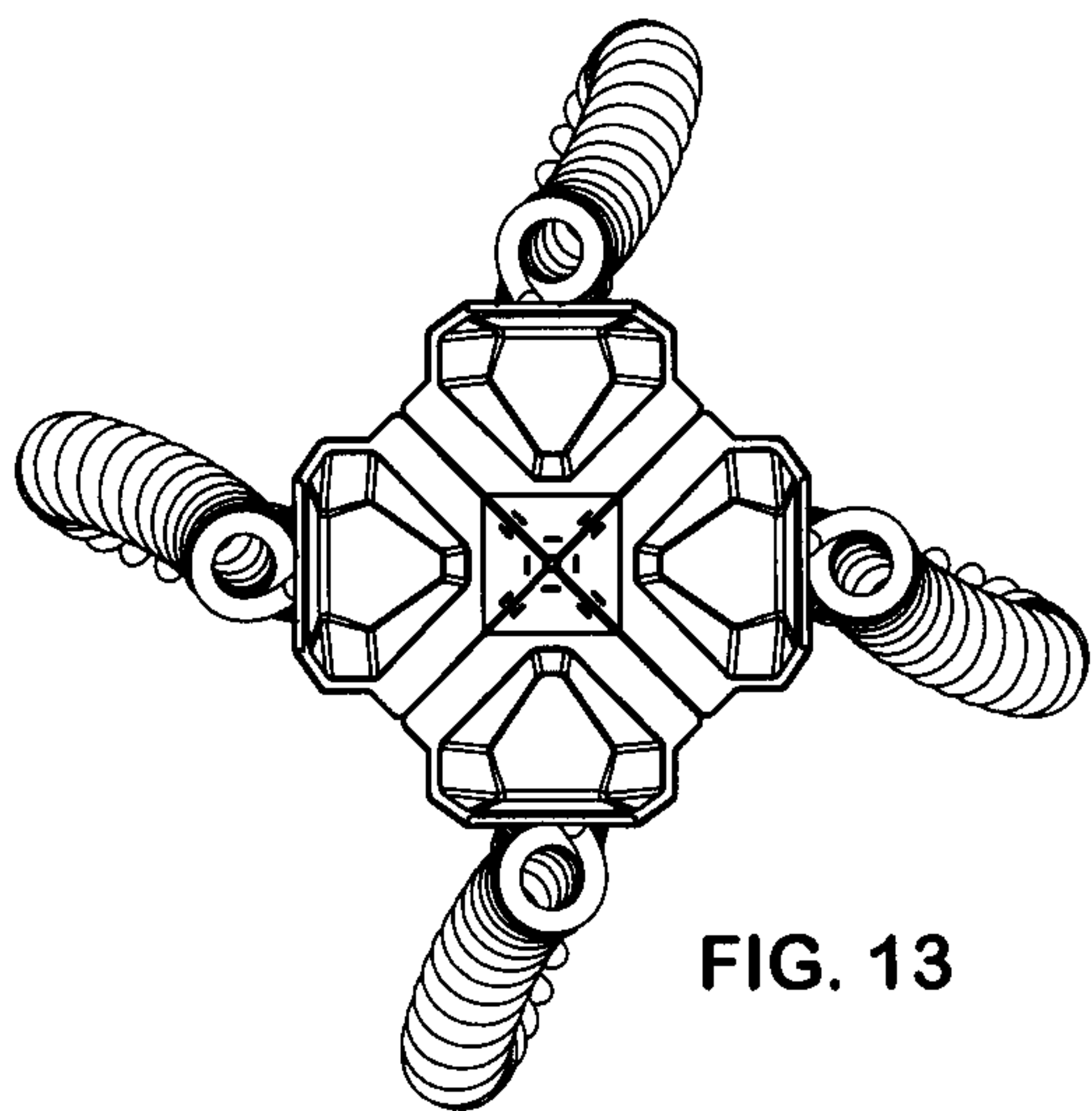

FIG. 13

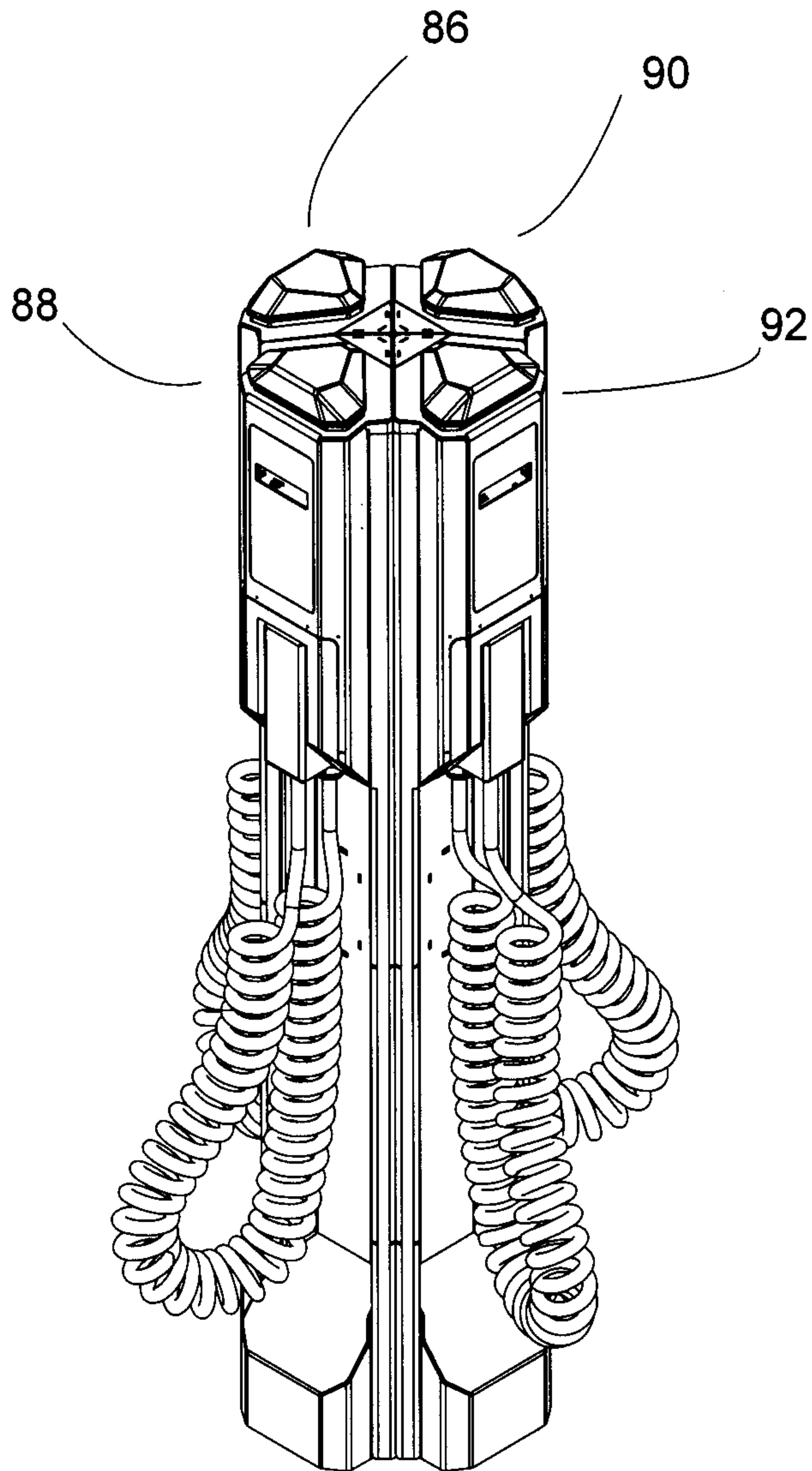

FIG. 12

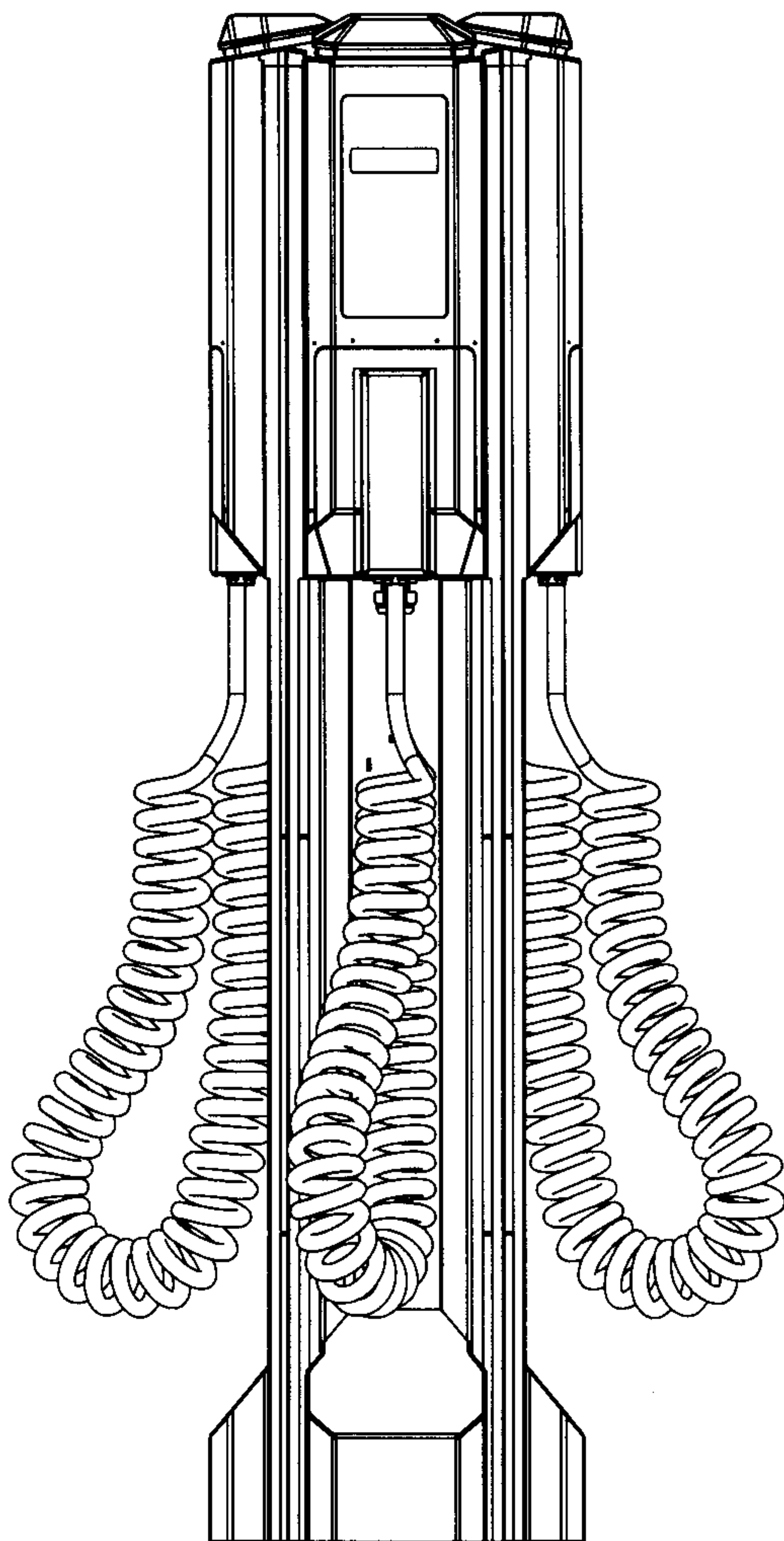

FIG. 11

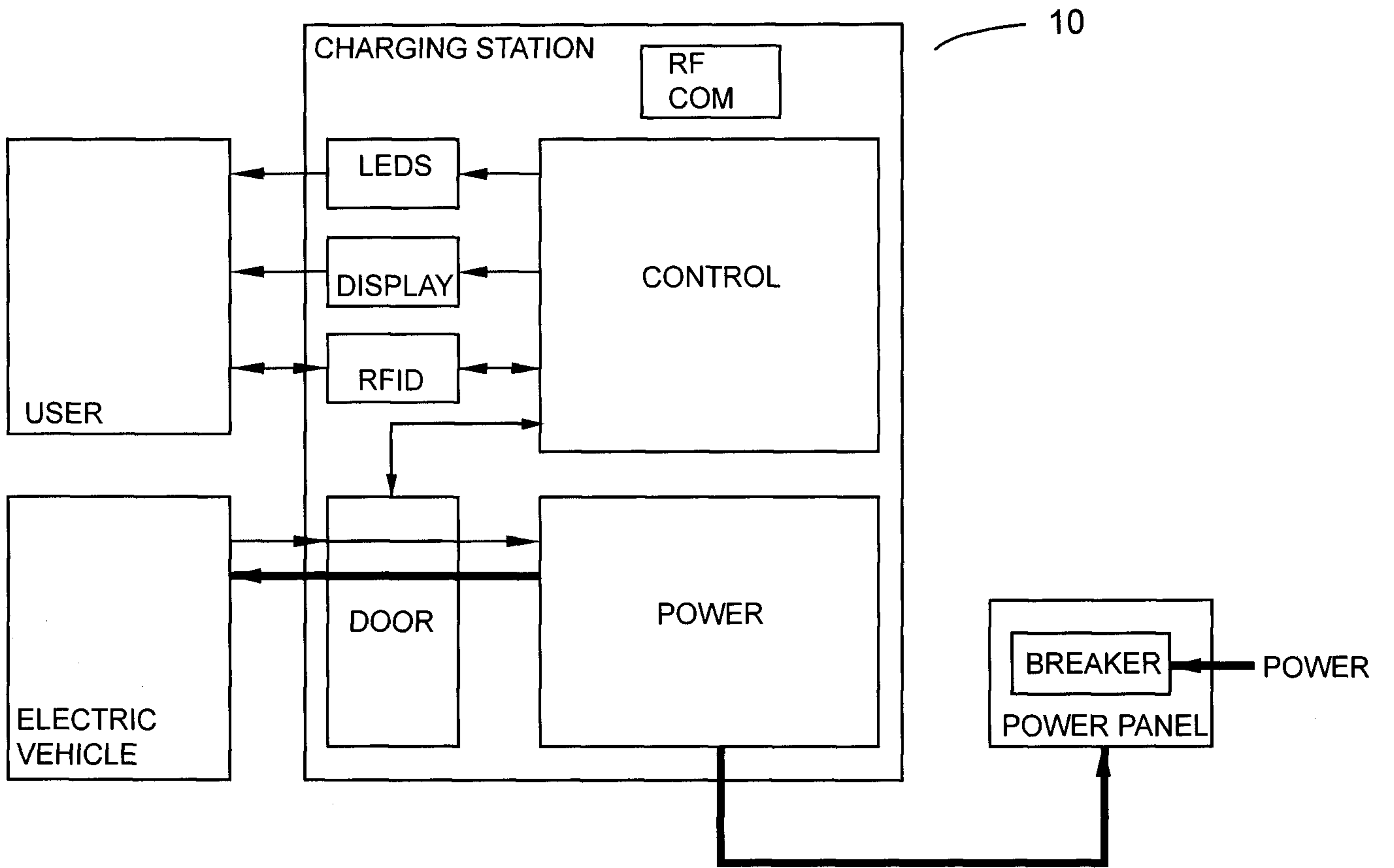

FIG. 15A

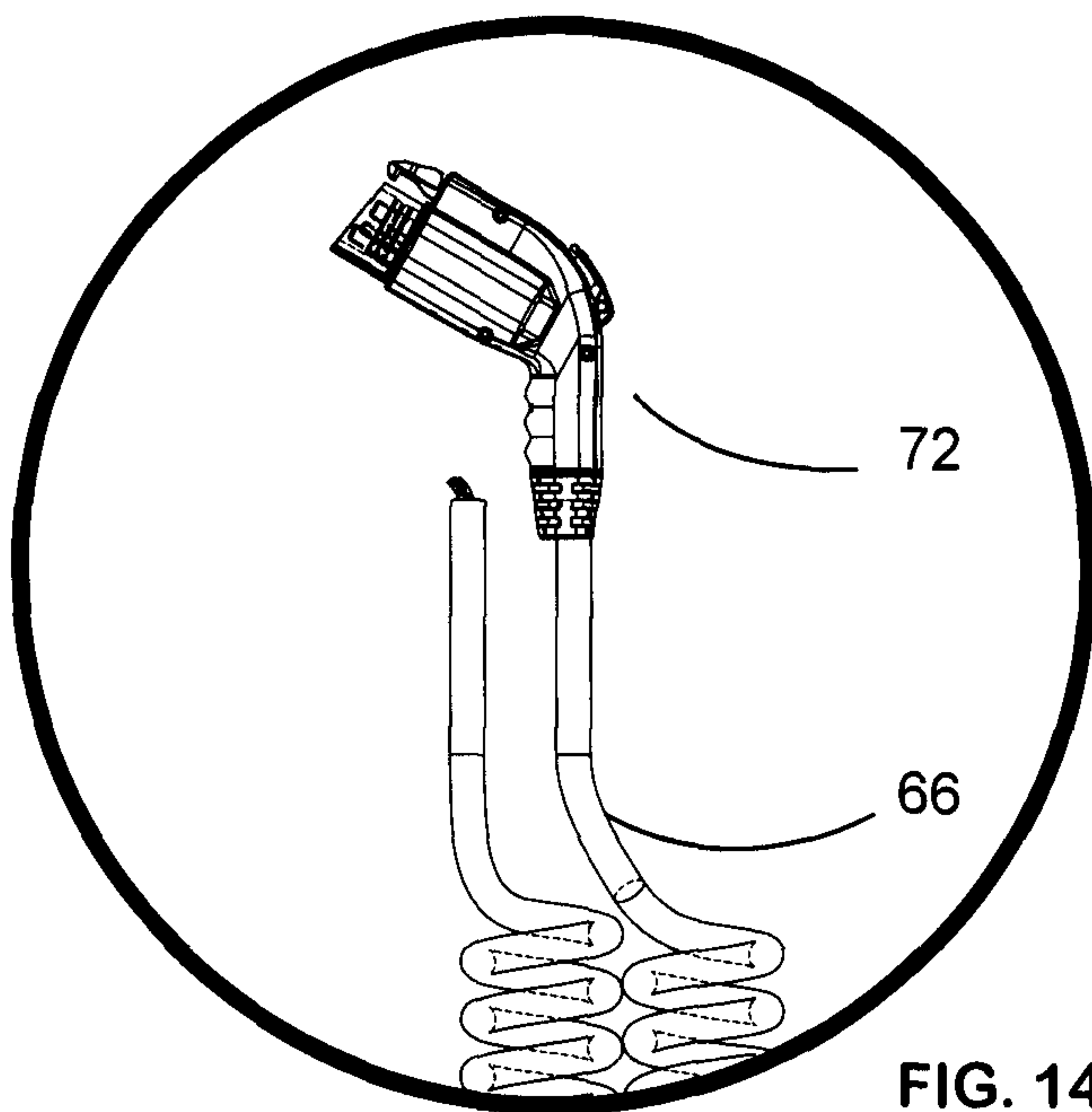

FIG. 14

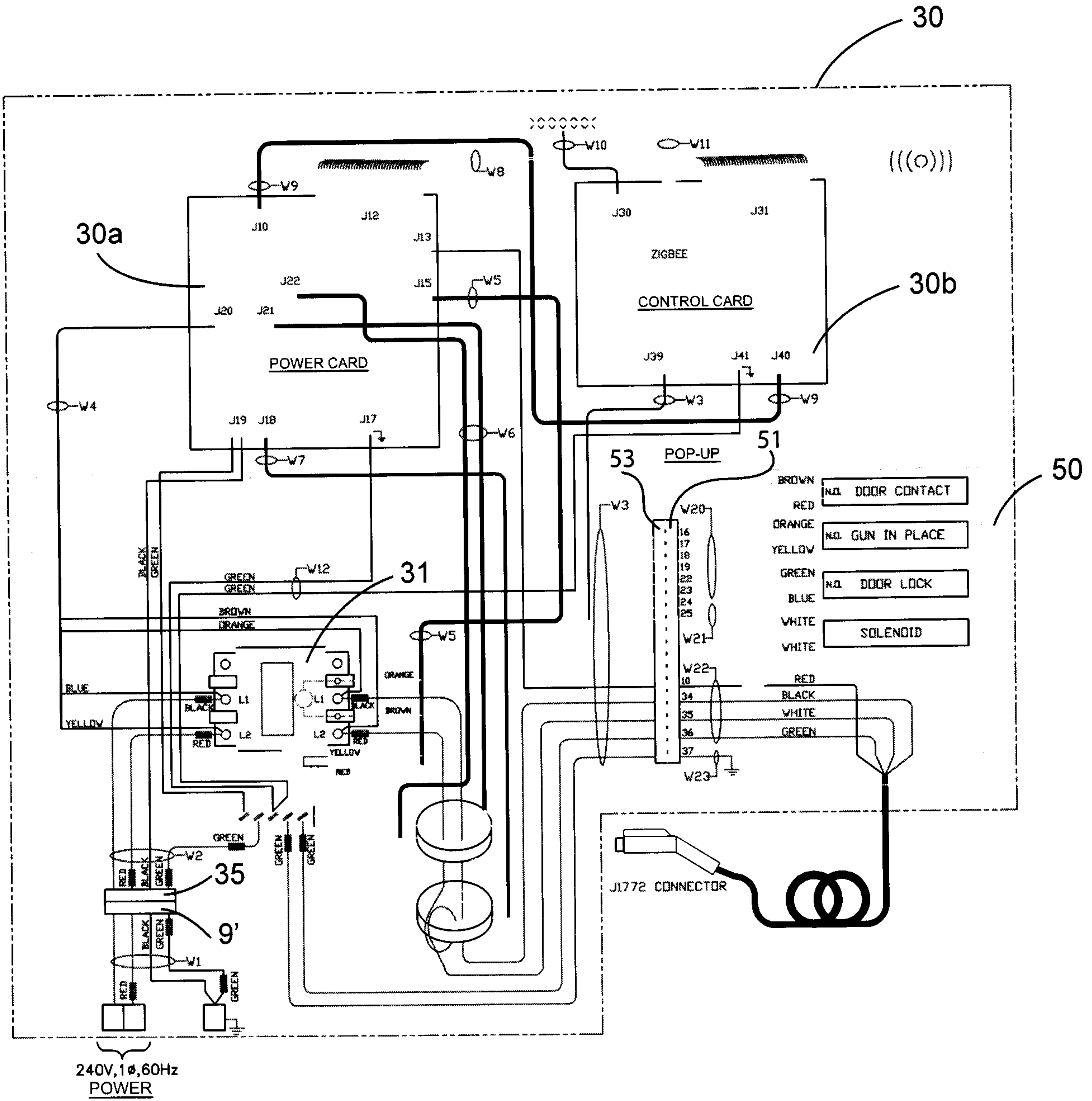

FIG. 15B

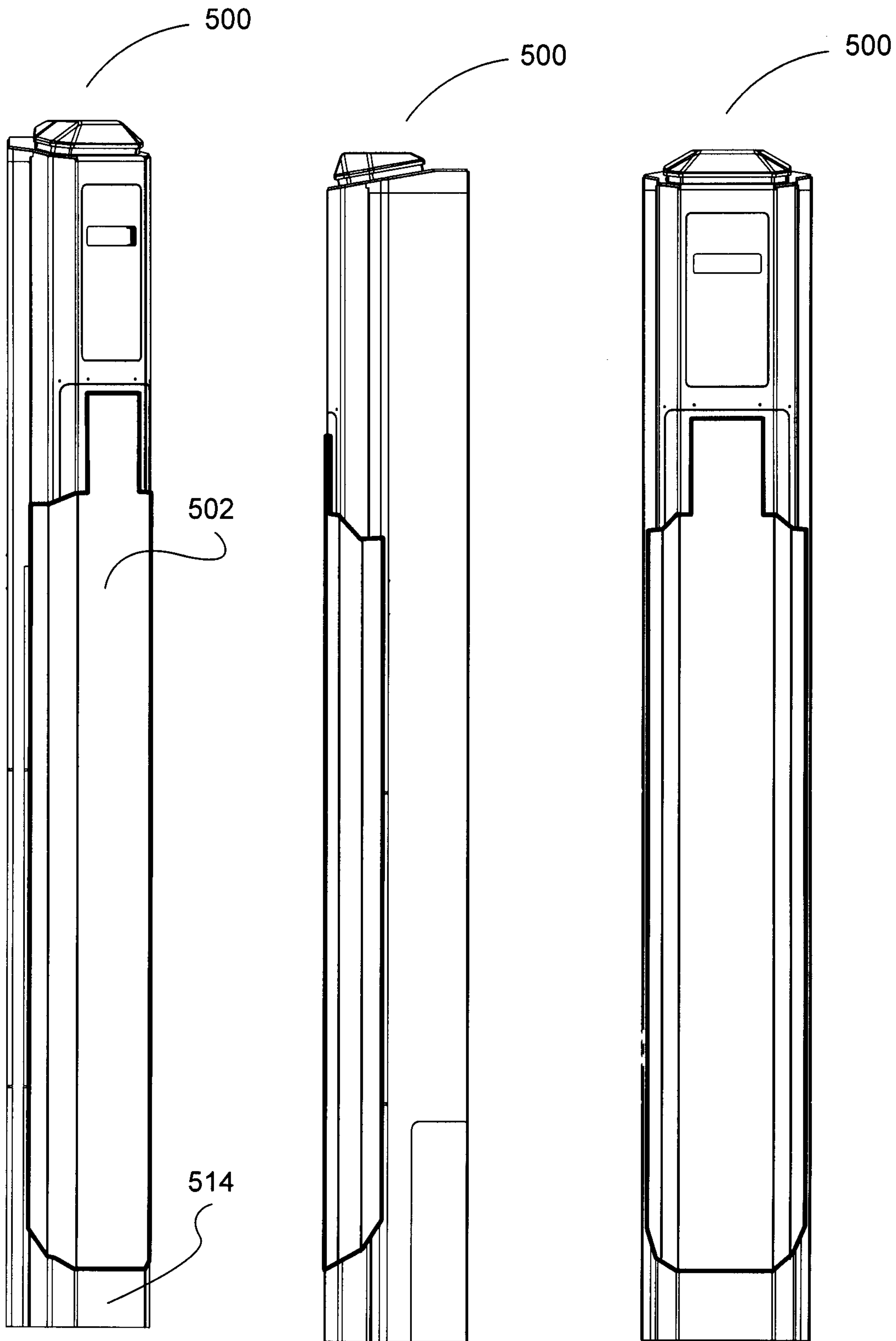

FIG. 16A

FIG. 16B

FIG. 16C

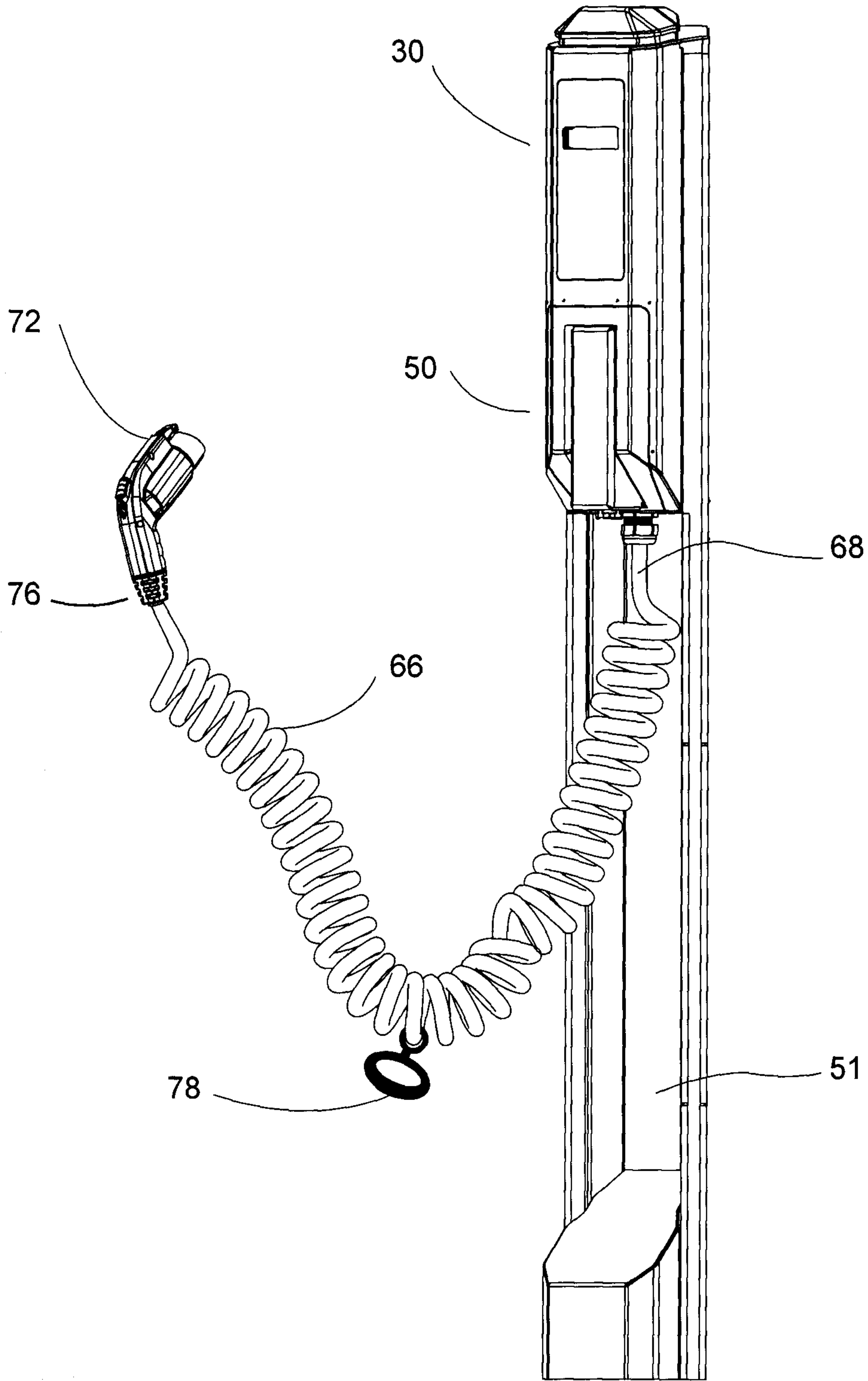

FIG. 17

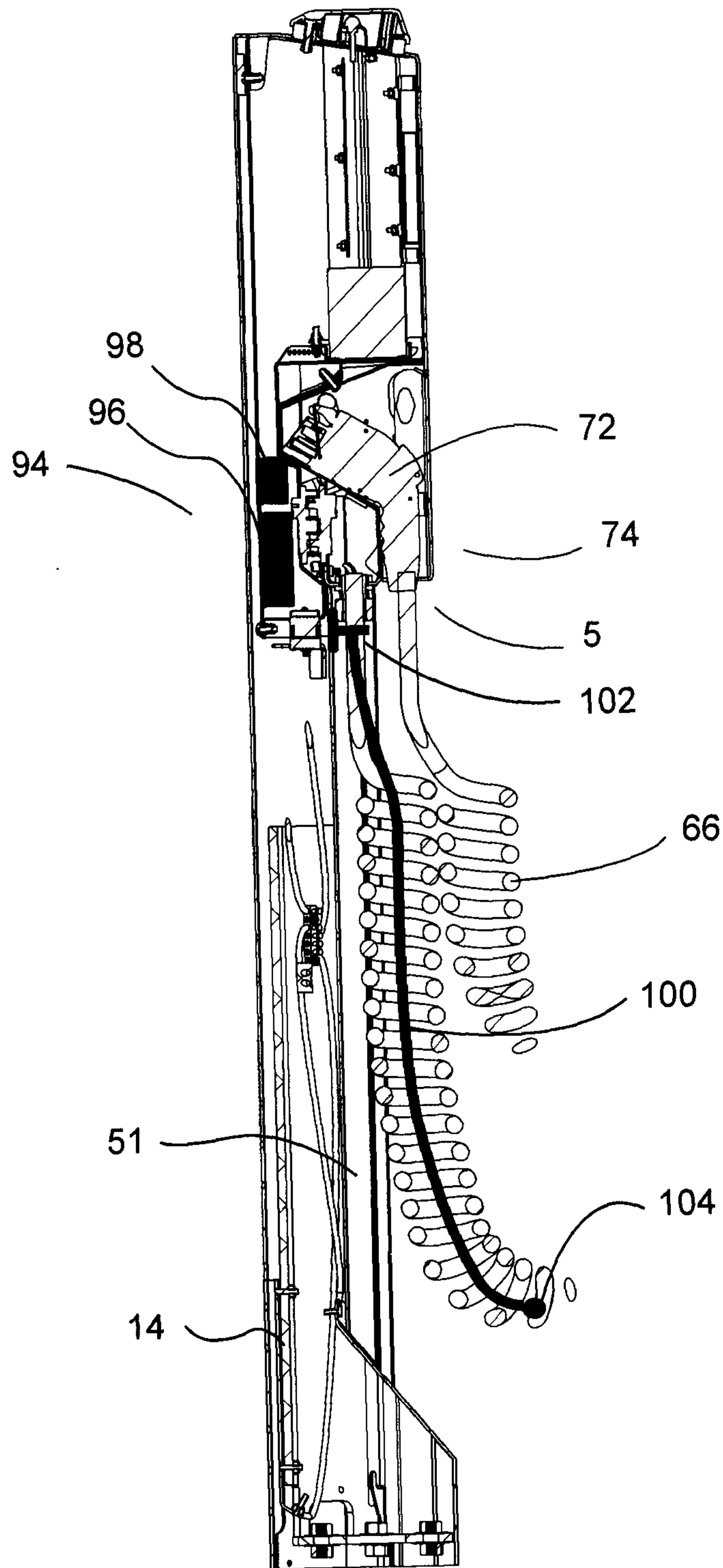

FIG. 18

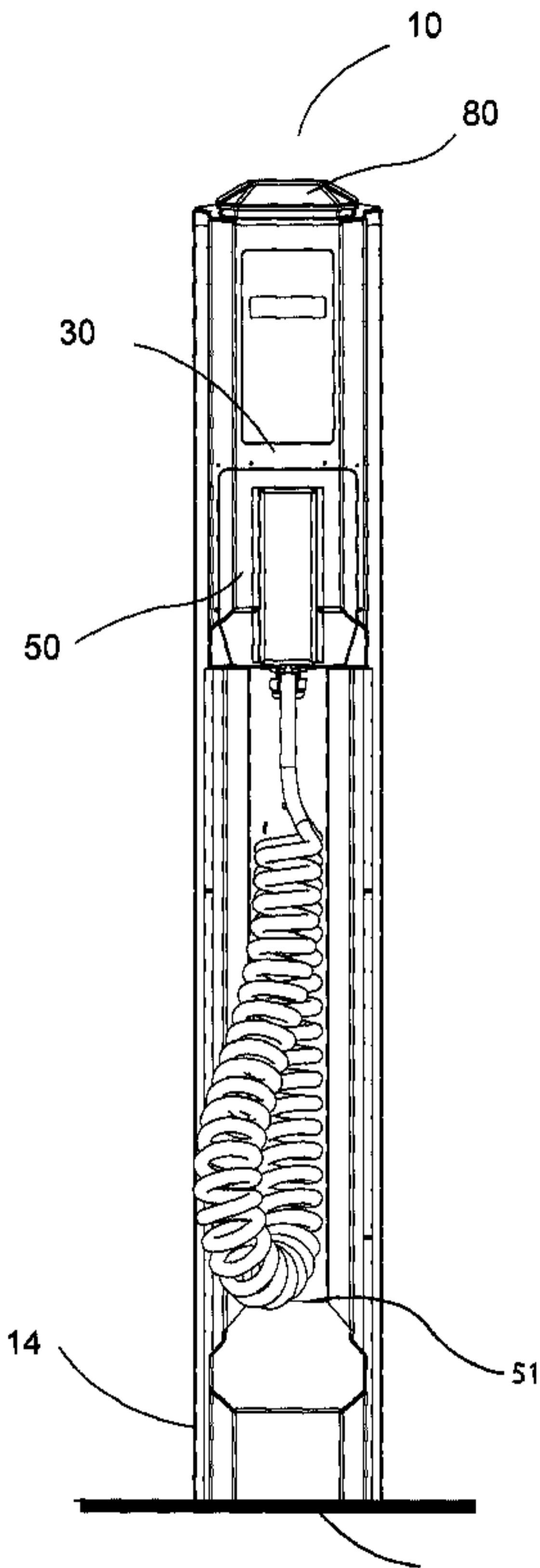

FIG. 1