



INTERNATIONAL APPLICATION PUBLISHED UNDER THE PATENT COOPERATION TREATY (PCT)

<p>(51) International Patent Classification <sup>5</sup> : E04B 1/72</p>	<p>A1</p>	<p>(11) International Publication Number: WO 94/19554 (43) International Publication Date: 1 September 1994 (01.09.94)</p>
<p>(21) International Application Number: PCT/AU94/00082 (22) International Filing Date: 23 February 1994 (23.02.94) (30) Priority Data: PL 7520 25 February 1993 (25.02.93) AU (71) Applicant (for all designated States except US): TERMI-MESH AUSTRALIA PTY. LTD. [AU/AU]; 10 Westchester Road, Malaga, W.A. 6062 (AU). (72) Inventor; and (75) Inventor/Applicant (for US only): TOUTOUNTZIS, Vasilios [AU/AU]; 4 Nerida Place, Sorrento, W.A. 6020 (AU). (74) Agent: WATERMARK PATENT &amp; TRADEMARK ATTORNEYS; 4th floor, "Durack Centre", 263 Adelaide Terrace, Perth, W.A. 6000 (AU).</p>	<p>(81) Designated States: AT, AU, BB, BG, BR, BY, CA, CH, CN, CZ, DE, DK, ES, FI, GB, GE, HU, JP, KG, KP, KR, KZ, LK, LU, LV, MD, MG, MN, MW, NL, NO, NZ, PL, PT, RO, RU, SD, SE, SK, TJ, UA, US, UZ, VN, European patent (AT, BE, CH, DE, DK, ES, FR, GB, GR, IE, IT, LU, MC, NL, PT, SE), OAPI patent (BF, BJ, CF, CG, CI, CM, GA, GN, ML, MR, NE, SN, TD, TG).</p> <p><b>Published</b> With international search report. Before the expiration of the time limit for amending the claims and to be republished in the event of the receipt of amendments.</p>	

(54) Title: IMPROVEMENTS RELATING TO TERMITE CONTROL

(57) Abstract

A barrier to termites particularly suitable for protecting buildings comprising a mesh (15) made of a material that is resistant to breakdown in the environment of use and is resistant to secretions deposited by termites, such as stainless steel, and is also sufficiently hard to not be attacked by termites, such as having a hardness not less than about Shore D70. The pores of the mesh (15) being dimensioned so the maximum linear dimension in any direction of the pores is less than the maximum linear dimension of the cross section of the head of the species of termite to be controlled. The mesh (15) being installed with respective marginal edges (16, 20) along opposite edges of the two sections of a building structure to prevent the passage of termites therebetween.

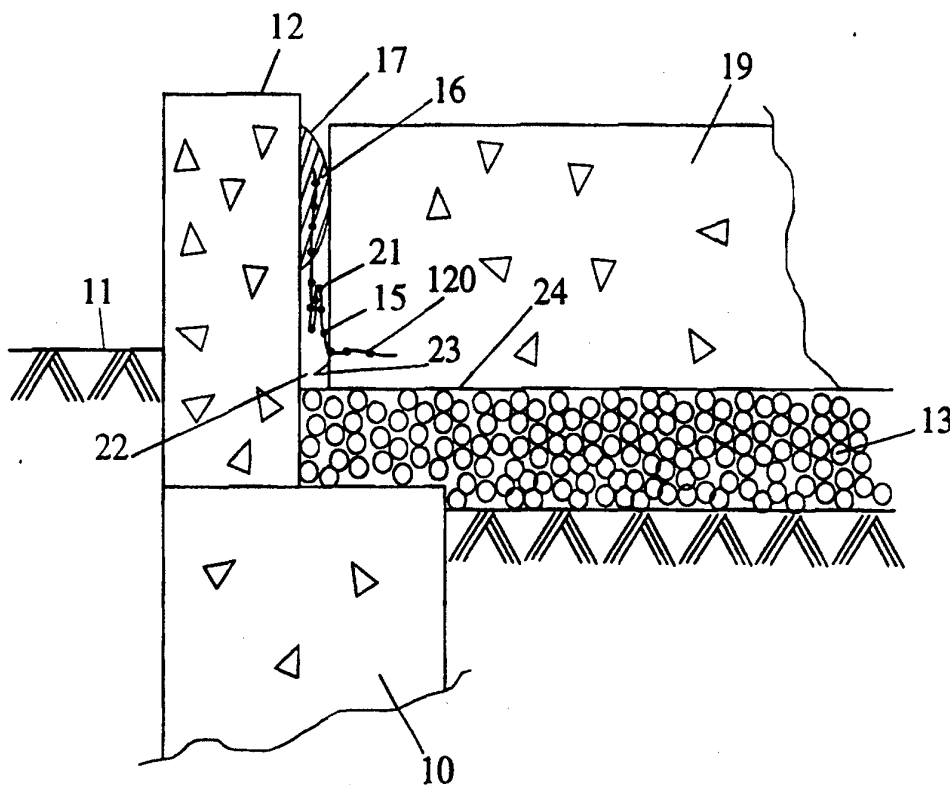

*FOR THE PURPOSES OF INFORMATION ONLY*

Codes used to identify States party to the PCT on the front pages of pamphlets publishing international applications under the PCT.

AT	Austria	GB	United Kingdom	MR	Mauritania
AU	Australia	GE	Georgia	MW	Malawi
BB	Barbados	GN	Guinea	NE	Niger
BE	Belgium	GR	Greece	NL	Netherlands
BF	Burkina Faso	HU	Hungary	NO	Norway
BG	Bulgaria	IE	Ireland	NZ	New Zealand
BJ	Benin	IT	Italy	PL	Poland
BR	Brazil	JP	Japan	PT	Portugal
BY	Belarus	KE	Kenya	RO	Romania
CA	Canada	KG	Kyrgystan	RU	Russian Federation
CF	Central African Republic	KP	Democratic People's Republic of Korea	SD	Sudan
CG	Congo	KR	Republic of Korea	SE	Sweden
CH	Switzerland	KZ	Kazakhstan	SI	Slovenia
CI	Côte d'Ivoire	LI	Liechtenstein	SK	Slovakia
CM	Cameroon	LU	Luxembourg	SN	Senegal
CN	China	LK	Sri Lanka	TD	Chad
CS	Czechoslovakia	LV	Latvia	TG	Togo
CZ	Czech Republic	MC	Monaco	TJ	Tajikistan
DE	Germany	MD	Republic of Moldova	TT	Trinidad and Tobago
DK	Denmark	MG	Madagascar	UA	Ukraine
ES	Spain	ML	Mali	US	United States of America
FI	Finland	MN	Mongolia	UZ	Uzbekistan
FR	France			VN	Viet Nam
GA	Gabon				

### **IMPROVEMENTS RELATING TO TERMITE CONTROL**

This invention relates to the control of termites from attacking buildings and other structures and, more specifically, to an improvement in or modification of the techniques for the control of termites in such situations as 5 disclosed in co-pending Australian Patent Application No. 62010/90, the disclosure in which is incorporated herein by way of this reference.

That prior application discloses the construction of a termite barrier and the application thereof to buildings incorporating or supported on a concrete slab and wherein the termite control is achieved without the use of harmful 10 chemicals which are currently deemed environmentally unacceptable. More specifically, there is disclosed in that prior application, a termite barrier material comprising a mesh sheet of a material resistant to breakdown in the environment of use and substantially resistant to termite secretions and has a hardness of not less than about Shore D70, the pores of said mesh having a 15 linear dimension in any direction less than the maximum linear dimension of the cross section of the head of the species of termite to be controlled. The above defined termite barrier material shall be referred to hereinafter as "the termite barrier material".

In the prior patent application, it has been proposed to underlay the 20 concrete slab with a continuous layer of the termite barrier material. However, in view of the strength of concrete slabs and the low probability of cracking thereof, the technique of underlaying the full extent of the concrete slab with the termite barrier material, involves a substantial waste of the barrier material and a consequential increase in the cost of providing the protection against the 25 intrusion of termites.

Accordingly, it is the object of the present invention to enable a building or like structure to be protected against the entry of termites using the termite barrier material, but in a more economic manner without seriously impairing the effectiveness of the barrier against the entry of termites to the 30 building.

With the above stated object in view, there is provided in combination with a building structure erected on a ground level or near ground

level concrete slab, and having a non integral termite resistant adjacent structure, a strip of termite barrier material, said strip having the respective marginal edge portions along the opposite longitudinal edges of the strip integrally secured to the slab and the adjacent structure to establish integrity of the connection between the slab and the adjacent structure against the passage of termites.

Conveniently, the adjacent structure may be a further concrete slab which can either be a lateral extension of the existing slab, or a vertical extension thereof such as a wall. Further, the adjacent structure may be a concrete beam or like structural member upon which a building or other structure is to be supported.

It is to be understood that termites that attack buildings are nearly always of the subterranean variety and cannot survive unless protected from direct exposure to ambient conditions including sunlight and thus, in the majority of environments, they cannot travel over the exposed surface of a component of the building and thus, it is only necessary to maintain the integrity of the termite barrier to a limited height above ground level. It is acknowledged the such termite can travel a considerable distance over external surfaces, but only by first building a gallery or "mud tube" over the external surface through which the termites can travel protected from ambient conditions. However the provision of the strip of termite barrier cause the termites to build a gallery further up the wall of the building thereby rendering easy detection of the presence of termites.

Where the slab and the adjacent structure are each cast in-situ concrete components, such as in construction and control joints, the respective marginal edge portions of the termite barrier strip can be embedded into the slab and adjacent structure during the pouring of the concrete thus, establishing the complete integrity of the barrier between the two concrete components. In other structures, one or both of the adjacent concrete components may be precast and in such situations, the marginal edge portions of the strip of termite barrier material, is bonded to the respective concrete structures by a suitable adhesive or bonding material which itself is resistant to attack by termites.

Preferably during such an installation, the marginal edge portions

of the termite barrier strip are secured at spaced intervals along the length of the joint by a mechanical connection, such as by concrete nails, and the adhesive or bonding material subsequently applied or applied in a combined operation with the application of the nails or fastenings. The use of the mechanical fastening is principally for the purpose of ensuring the marginal edge portion of the termite barrier strip is held in the correct location and in intimate contact with the slab or other structure while the adhesive or bonding material is applied and cures.

Preferably, the strip of termite barrier material has a re-entrant fold extending the length of the strip and located between the marginal edge portions that are secured to the slab and adjacent structure respectively. This fold provides an enhanced level of stretchability and flexibility of the strip to accommodate movement, between the slab and/or the adjacent structure after installation of the barrier strip, without risk of damage to the attachment of the marginal portions of the barrier strip to the slab and adjacent structure respectively. This construction is particularly suitable where the barrier strip may be provided to interconnect two sections of a structure having an expansion of control joint therebetween as is commonly required in concrete buildings or structures.

The invention will be more fully understood from the following description of a number of practical applications of the termite barrier material as illustrated in the accompanying drawings.

In the drawings,

Figure 1 shows diagrammatically the installation of a termite barrier in a structure having separately formed floor and wall sections.

Figure 2 shows diagrammatically the installation of a termite barrier between an existing structure and a structure under construction.

Figure 3 shows diagrammatically the installation of a termite barrier in an existing structure having existing floor and wall components.

Figure 4 shows diagrammatically the installation of a termite barrier in a structure incorporating a cavity wall.

Figure 5 shows diagrammatically the installation of a termite barrier between laterally adjacent structures.

Figure 6 shows diagrammatically the installation of a termite barrier about a conduit extending through a concrete slab.

Referring now to Figure 1 of the drawings, there is shown in a simplified representation, a cross section through part of the footing, base slab 5 and wall of a building at the junction thereof. The footing 10 is constructed of concrete, with appropriate metal reinforcement, and is located some distance below the normal surface of the ground indicated at 11. The concrete beam 12 can be cast insitu or precast, and is located in position on the footing 10, a series of such beams being provided to form the perimeter of the base of the building. 10 As the beams 12 can be precast and subsequently transported to the building site, it is not servicable to have a portion of the strip of termite barrier material embedded in the beam during the casting thereof, particularly in view of the possibility of damage to the barrier material during subsequent transportation and installation of the beams.

15 Following completion of the erection of the perimeter beams upon the footings, the area bounded by the series of beams is prepared for pouring of the concrete slab by the laying down and compacting of a bed of stones as indicated at 13. Also prior to pouring of the slab, a continuous strip 15 of the termite barrier material has one marginal edge portion 16 applied to the internal 20 face of the beam 12 by appropriate mechanical fixings such as concrete nails and/or and a layer of adhesive, as indicated at 17. After curing of the adhesive cement, the concrete floor slab 19 is poured and during such pouring the other marginal edge portion 20 of the barrier strip is embedded in the concrete slab 19.

25 The concrete of the slab may extend up to and abut the internal face of the beams 12, thereby also encasing the marginal portion 16 of the termite barrier strip that is adhered to the beam 12. Alternatively, an expansion gap may, as indicated at 22, is left between the perimeter edge of the slab 19 and the opposite face of the adjacent beam 12. Where such an expansion gap 30 is left, as seen in Figure 1, the termite barrier strip is provided with a re-entrant fold 21 extending the length thereof to provide flexibility and freedom for movement of the floor slab relative to the beams without the risk of fracture of the

termite barrier strip.

As shown in Figure 1, the marginal edge portion 20 extends into the slab through the edge face 23 thereof. However, it is to be understood that the termite barrier strip may also extend to the underside of the slab with the marginal portion then projecting upwardly into the under side 24 of the slab 19.

It is also to be understood that the beam 12 as shown in Figure 1 can be replaced by a cast in-situ or precast wall or similar upwardly extending member. In such an arrangement the termite barrier strip 15 can be installed as shown in Figure 1 or each marginal edge portion of the strip 15 can be embedded in the slab and upright member respectively during casting of each or can be embedded in one and adhered or bonded to the other or adhered or bonded to both. In constructions where the slab and member are cast separately with the termite barrier strip embedded in each, it is preferable to provide a re-entrant fold 21 extending the length of the barrier strip to provide the ability for limited freedom of movement between the structural members without fracture of the barrier strip.

The above description of the installation of the termite barrier strip between a beam or wall and a slab may also be applied to providing an effective termite barrier between an existing concrete member and a newly cast member which may be functioning as an extension of an existing structure. In such circumstances, the same technique and layout as above discussed with respect to the beam and slab, may be applied to extending an existing slab.

One example of such an application of the termite barrier material is illustrated in Figure 2 wherein an existing structure 30 is depicted as a floor slab 31 supported on a footing 32 and supporting a wall 33, is extended by a further floor slab 35. In Figure 2, the footing 32 is shown displaced downward from the slabs 31 and 35 for convenience of illustration, however it will be understood that the perimeter of the slabs set on the footing is in the conventional manner.

Prior to pouring the further slab 35, the strip 36 of termite barrier material is positioned to extend along the length of the vertical edge face of the existing slab 31 so that when the further slab 35 is poured, or positioned on the

footing, the portion 37 of the barrier strip is located therebetween. Also, prior to the pouring of the further slab 35, the remainder portion 38 of the barrier strip is located on the top of the footing 32 where the further slab is to be poured. This remaining portion 38 of the barrier strip is formed to provide an anchor portion 5 39 and the fold portion 40. The anchor portion 39 is upstanding from the footing to generally extend upward and be embedded in the further slab 35 when poured to provide a sealed connection therebetween. Prior to the positioning of the further slab 35, an adhesive mixture is applied to the portion 37 of the barrier strip to secure and seal the portion of the barrier strip to the existing slab.

10           The fold portion 40 provides for limited movement between the two slabs 31 and 35 without over stressing of the barrier strip to an extent to fracture the strip. A sheet of thin plastic or low friction material is placed over the re-entrant fold 40 to assist in movement between the slab and the re-entrant fold of barrier strip and to protect the strip in the event of such movement.

15           Although the description in respect to Figure 2 specifically refers to forming a termite barrier between an existing slab or a newly poured slab, the same form of termite barrier can be constructed between other structural components where one exists and the other is newly constructed. By way of example, the barrier construction can be employed between a slab and a wall, 20 between two parallel walls, between two intersecting walls, and between any two adjacent structural components or structures.

Referring now to Figure 3 of the drawings there is illustrated a further application of the termite barrier strip along the external perimeter wall of an existing building. In this situation, the existing building comprises a 25 conventional poured concrete footing 46, a floor slab 41, and an external wall 42 which may be in the form of a brick, block or poured concrete construction. In such an existing structure, there is no convenient access to the underside of the slab 41 or the interface between the slab and the wall 42 and accordingly, it is necessary to install the termite barrier strip externally.

30           This is achieved by initially removing the earth adjacent the external wall to a depth to expose the existing concrete footing 46 and then apply the termite barrier strip 43 extending up the external face of the wall 42

from the footing 46 to a substantial distance above the normal surrounding ground level. The lower marginal edge portion 44 of the termite barrier strip, is seated on the footing 46, and secured to the footing and the lower portion of the external face of the wall 42 by suitable adhesive as indicated at 45. The upper 5 marginal portion 47 of the termite barrier strip 43 is anchored to the blocks of the wall 44 by concrete nails of the like at suitable intervals along the length, or may be secured thereto by the use of adhesive cement or mortar alone or together with the nails.

It is to be noted that, in view of the inability of the termites to 10 survive when exposed to ambient conditions, it is only necessary for the barrier strip to extend approximately 100 to 200 millimetres above normal ground level to provide an effective barrier to prevent termites entering the building or to cause them to build external galleries that are readily visible and hence the presence of termites is detectable.

15 There is shown in Figure 4 an alternative construction to that shown in Figure 1 which is suitable for use during the construction of the building as compared with that shown in Figure 3 which is more appropriate for application to existing buildings. In Figure 4, the conventional footing 48, floor slab 49 and external cavity wall structure 50 are basically of the same 20 construction as that previously described with respect to Figure 3. The termite barrier strip 51 has a lower edge portion 52 thereof embedded into the slab 49 during the pouring of the latter and is subsequently positioned in the cavity 53 of the wall structure 50. During the laying of the bricks or blocks 53 which form the outer wall 50a of the wall structure, the upper edge portion 56 of the barrier strip 25 51 is positioned between two adjacent layers of bricks or blocks with the normal mortar or cement located on either side of the marginal edge portion of the barrier strip, so that when the wall structure is finished, the upper edge portion of the barrier strip is integral with the wall structure and will prevent the passage of termites up through the wall cavity 53.

30 The construction described above with reference to Figure 4 is for use where the termite barrier strip is installed during construction prior to the pouring of the slab 49. There is shown in Figure 5 the variation where the

barrier strip is installed after the slab has been constructed and/or when a single brick wall is used as an alternative to a double brick (cavity) wall as shown in Figure 4.

As shown in Figure 5, one marginal edge portion 55 of the termite barrier strip 56 is secured to the top face 57 of the slab 49 such as by nails and/or an adhesive or mortar. The opposite marginal edge portion 58 is positioned between two adjacent layers of the bricks or blocks with the normal mortar or cement located on either side of the marginal edge portion 58. As shown in Figure 5, the portion of the barrier strip 59 spanning the space 10 between the slab and the wall is in a folded form to accommodate movement between the wall and the slab without strain or the risk of fracture of the barrier strip.

In the previous description of the practical application of the present invention, reference has been made to using adhesive cement to secure a marginal edge portion of the barrier strip to an adjacent member which may be concrete or building bricks or blocks. The nature of the adhesive cement may be a mixture of conventional cement and fine sized sand and to which there is added a proprietary cement adhesive agent. Preferably the cement adhesive is synthetic polymer based. The sand used in the adhesive cement is selected so that it is sufficiently fine that the individual particles will freely pass through the openings in the mesh of the barrier strip. This ensures an effective bond between the barrier strip and the adjacent structural member, and to prevent the possible formation of areas which are not adhered and therefore potential passages for termites. The cement mix should have a high cement content preferably of the order of 2 to 3 parts sand to one part cement.

It is frequently necessary in building structures to provide conduits, such as water or waste pipes, which project through the ground slab of the structure, and the opening provided in the slab for this purpose is a potential avenue for the passage of termites. Referring now to Figure 6, in order to preclude the passage of termites, it is proposed that a sheet 54 of barrier material with a central aperture of lesser diameter than the conduit 53. Prior to the pouring of the slab, the aperture portion is stretched to increase the diameter

of the aperture to form a sleeve 55 to receive the conduit 53. The sleeve 55 is fitted to the conduit 53 and clamped about the exterior thereof such as by a conventional stainless steel hose clip 57. During the subsequent pouring of the slab 56, the outer perimeter area 58 of the sheet of termite barrier material is 5 embedded in the concrete and thereby provide an effective barrier to the passage of termites between the conduit 53 and the slab 56.

In a modification of the termite barrier installation shown in Figure 3 the termite barrier strip 43 is folded along a longitudinal line so that the two marginal edges thereof overlay and both edges are located between the footing 10 46 and the lower brick or block of the wall 42. The edges of the barrier strip are embedded in the mortar to secure it in place before the bricks or blocks are erected. The folded portion of the strip projects laterally from the wall and is contoured to form an open bulbous shape that is relatively flexible and porous to water and will thus not support a termite gallery.

15           The termite barrier material and installations thereof as previously described with reference to the accompanying drawings may be used in many other applications where the passage of termites is required to be prevented without departing from the present invention.

THE CLAIMS DEFINING THE INVENTION ARE AS FOLLOWS:

1. In a building structure incorporating at or adjacent ground level two non-integral adjacent termite resistant structure sections, a strip of termite barrier material as hereinbefore defined having the respective opposite longitudinal marginal edge portions thereof integrally secure to the respective structural sections to establish integrity of the connection between the adjacent structural sections against the passage of termites therebetween.
2. In combination with a building structure incorporating a ground level or near ground level concrete structure and having a non-integral termite resistant adjacent structure, a strip of termite barrier material as herein before defined having the respective opposite longitudinal marginal edge portions integrally secured to the concrete structure and the adjacent structure to establish integrity of the connection between the concrete structure and the adjacent structure against the passage of termites.
3. The combination claimed in claim 2 wherein the adjacent structure is a lateral or vertical extension of the slab concrete structure.
4. The combination claimed in claim 2 wherein the adjacent structure is an upstanding wall or structure.
5. The combination as claimed in claim 1 or 2 wherein the adjacent structure is a wall spaced laterally from the slab.
6. The combination as claimed in claims 1 or 2 wherein the adjacent structure is a wall upstanding from the other structure or slab.
7. The combination claimed in claim 1 or 2 wherein one marginal longitudinal edge portion of the strip is embedded in one of the structure sections or the concrete structure.

8. The combination as claimed in claim 7 wherein the other marginal edge portion of the strip is embedded in the other structural section or the adjacent structure.

9. The combination as claimed in claim 7 wherein the other marginal edge portion of the strip is bonded to the other structural section or the adjacent structure to provide a termite impervious connection therebetween.

10. The combination as claimed in any one of claims 1 to 9 wherein the strip of termite barrier material has been the respective longitudinal marginal edge portions thereof a re-entrant fold extending longitudinally thereof.

11. The combination as claimed in claim 2, wherein a member projects through the slab, and a sleeve of termite barrier material is located about the periphery of the member and clamped in pressure engagement therewith about the complete perimeter of the member, and an integral flange of said termite barrier material projects from said sleeve and is sealably embedded in said slab.

12. The combination claimed in claim 1 wherein the respective longitudinal edge portions of the termite barrier strip are received in sealed relation between the respective structures sections and form a bulbous lateral projection from the structures.

1/3

Fig 1.

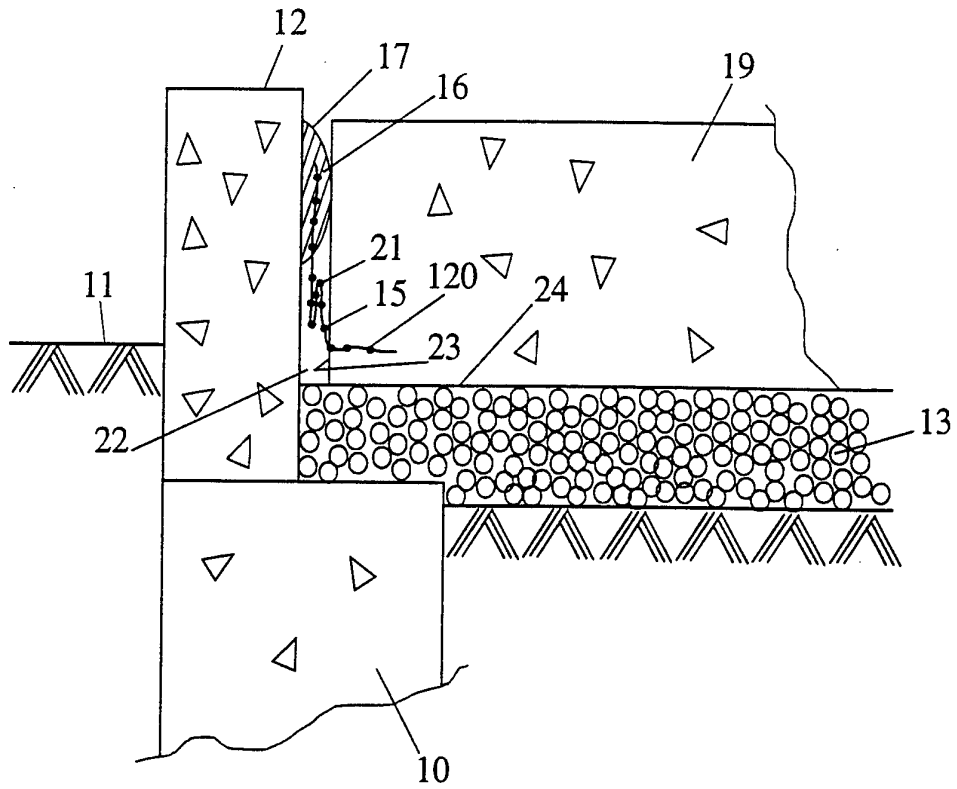
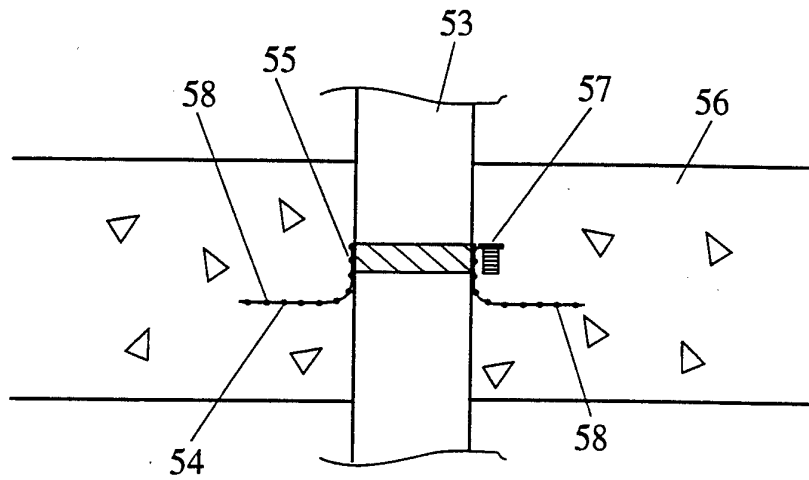

Fig 6.



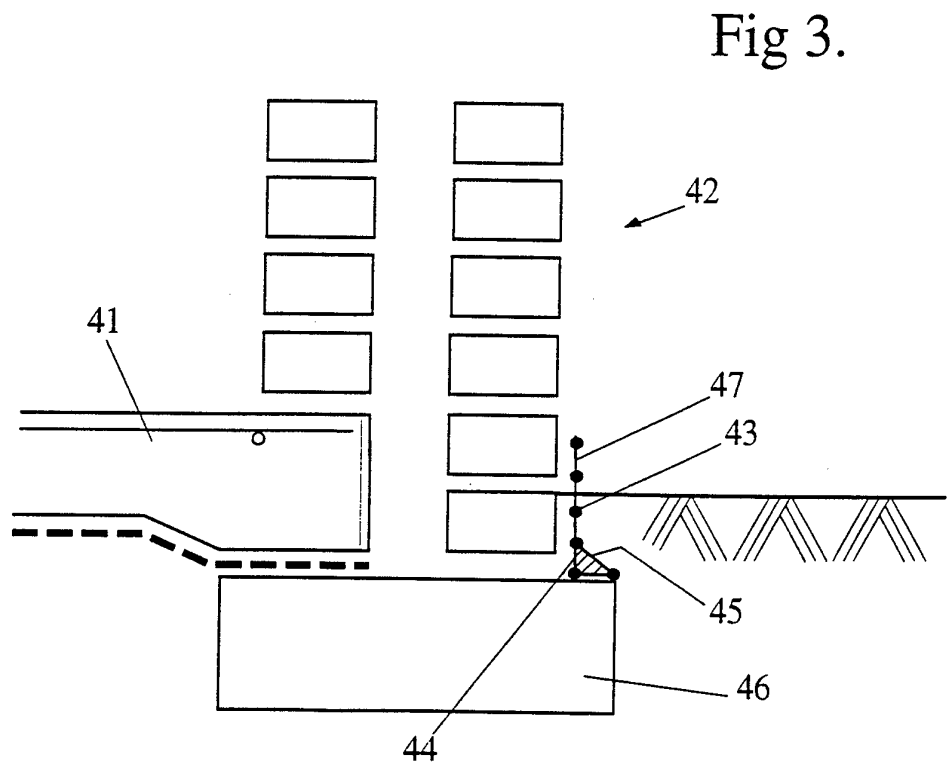
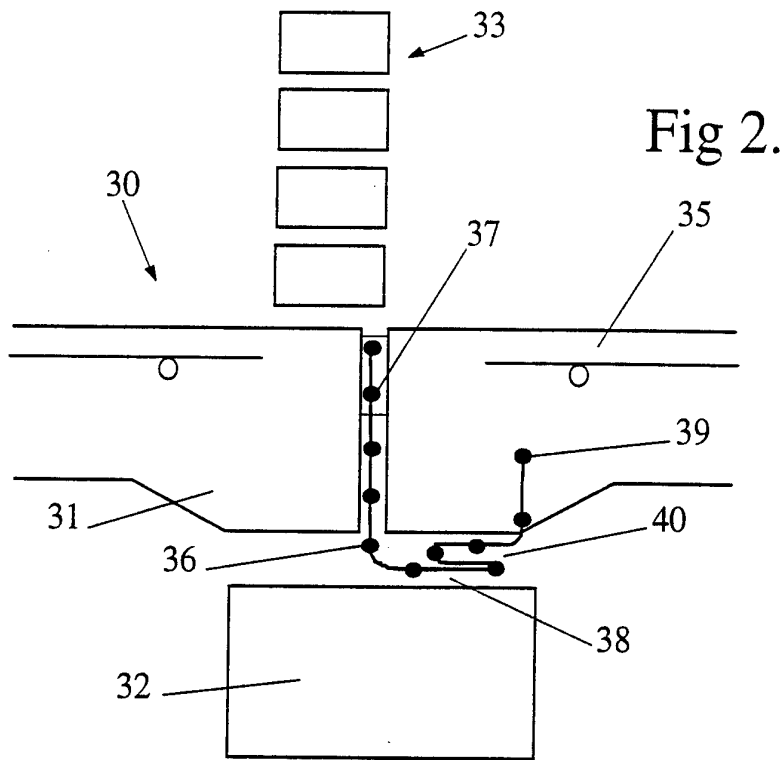

Fig 4.

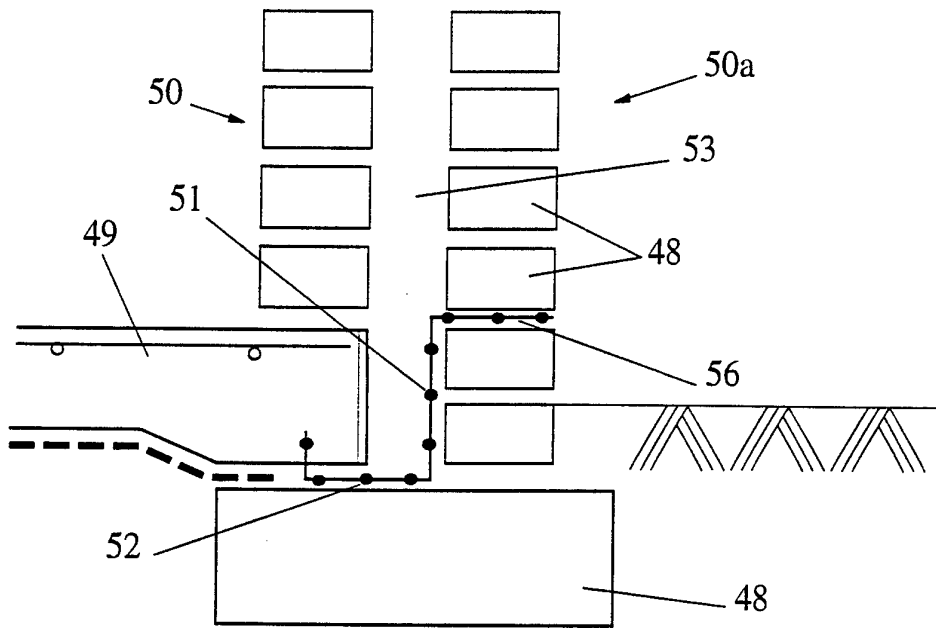
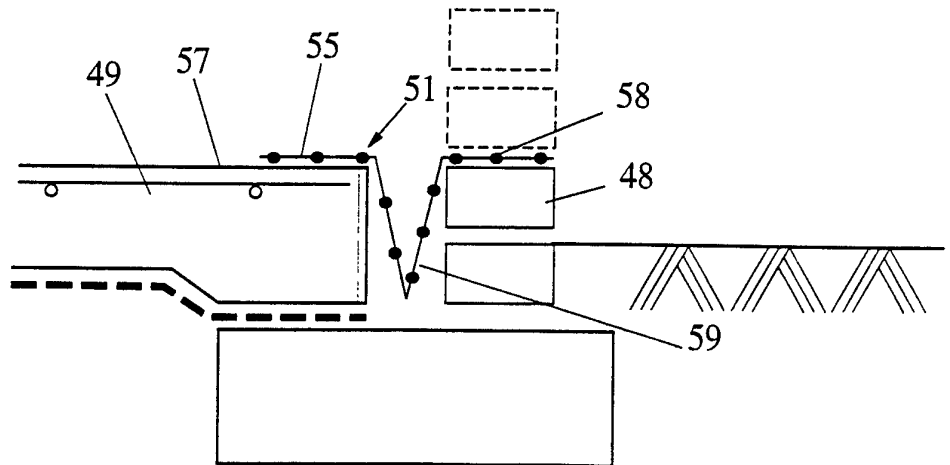



Fig 5.



<p><b>A. CLASSIFICATION OF SUBJECT MATTER</b>                  Int. Cl.<sup>5</sup> E04B 1/72</p> <p>According to International Patent Classification (IPC) or to both national classification and IPC</p>														
<p><b>B. FIELDS SEARCHED</b></p> <p>Minimum documentation searched (classification system followed by classification symbols)                  IPC : E04B 1/72</p> <p>Documentation searched other than minimum documentation to the extent that such documents are included in the fields searched                  AU : IPC as above</p> <p>Electronic data base consulted during the international search (name of data base, and where practicable, search terms used)                  JAPIO                  DERWENT</p>														
<p><b>C. DOCUMENTS CONSIDERED TO BE RELEVANT</b></p> <table border="1" style="width:100%; border-collapse: collapse;"> <thead> <tr> <th style="width:10%;">Category*</th> <th style="width:70%;">Citation of document, with indication, where appropriate, of the relevant passages</th> <th style="width:20%;">Relevant to Claim No.</th> </tr> </thead> <tbody> <tr> <td style="text-align:center">X</td> <td>AU,B, 62010/90 (639256) (TOUTOUNTZIS) 7 March 1991 (07.03.91) Whole document.</td> <td style="text-align:center">1-8</td> </tr> <tr> <td style="text-align:center">A</td> <td>US,A, 5224288 (SKELTON et al) 6 July 1993 (06.07.93)</td> <td></td> </tr> <tr> <td style="text-align:center">A</td> <td>EP,A, 521570 (JAG TEN BERG) 7 January 1993 (07.01.93)</td> <td></td> </tr> </tbody> </table>			Category*	Citation of document, with indication, where appropriate, of the relevant passages	Relevant to Claim No.	X	AU,B, 62010/90 (639256) (TOUTOUNTZIS) 7 March 1991 (07.03.91) Whole document.	1-8	A	US,A, 5224288 (SKELTON et al) 6 July 1993 (06.07.93)		A	EP,A, 521570 (JAG TEN BERG) 7 January 1993 (07.01.93)	
Category*	Citation of document, with indication, where appropriate, of the relevant passages	Relevant to Claim No.												
X	AU,B, 62010/90 (639256) (TOUTOUNTZIS) 7 March 1991 (07.03.91) Whole document.	1-8												
A	US,A, 5224288 (SKELTON et al) 6 July 1993 (06.07.93)													
A	EP,A, 521570 (JAG TEN BERG) 7 January 1993 (07.01.93)													
<p><input type="checkbox"/> Further documents are listed in the continuation of Box C.</p> <p style="text-align:right;"><input checked="" type="checkbox"/> See patent family annex.</p>														
<p>* Special categories of cited documents :</p> <table style="width:100%;"> <tr> <td style="width:50%; vertical-align: top;"> <p>"A" document defining the general state of the art which is not considered to be of particular relevance</p> <p>"E" earlier document but published on or after the international filing date</p> <p>"L" document which may throw doubts on priority claim(s) or which is cited to establish the publication date of another citation or other special reason (as specified)</p> <p>"O" document referring to an oral disclosure, use, exhibition or other means</p> <p>"P" document published prior to the international filing date but later than the priority date claimed</p> </td> <td style="width:50%; vertical-align: top;"> <p>"T" later document published after the international filing date or priority date and not in conflict with the application but cited to understand the principle or theory underlying the invention</p> <p>"X" document of particular relevance; the claimed invention cannot be considered novel or cannot be considered to involve an inventive step when the document is taken alone</p> <p>"Y" document of particular relevance; the claimed invention cannot be considered to involve an inventive step when the document is combined with one or more other such documents, such combination being obvious to a person skilled in the art</p> <p>"&amp;" document member of the same patent family</p> </td> </tr> </table>			<p>"A" document defining the general state of the art which is not considered to be of particular relevance</p> <p>"E" earlier document but published on or after the international filing date</p> <p>"L" document which may throw doubts on priority claim(s) or which is cited to establish the publication date of another citation or other special reason (as specified)</p> <p>"O" document referring to an oral disclosure, use, exhibition or other means</p> <p>"P" document published prior to the international filing date but later than the priority date claimed</p>	<p>"T" later document published after the international filing date or priority date and not in conflict with the application but cited to understand the principle or theory underlying the invention</p> <p>"X" document of particular relevance; the claimed invention cannot be considered novel or cannot be considered to involve an inventive step when the document is taken alone</p> <p>"Y" document of particular relevance; the claimed invention cannot be considered to involve an inventive step when the document is combined with one or more other such documents, such combination being obvious to a person skilled in the art</p> <p>"&amp;" document member of the same patent family</p>										
<p>"A" document defining the general state of the art which is not considered to be of particular relevance</p> <p>"E" earlier document but published on or after the international filing date</p> <p>"L" document which may throw doubts on priority claim(s) or which is cited to establish the publication date of another citation or other special reason (as specified)</p> <p>"O" document referring to an oral disclosure, use, exhibition or other means</p> <p>"P" document published prior to the international filing date but later than the priority date claimed</p>	<p>"T" later document published after the international filing date or priority date and not in conflict with the application but cited to understand the principle or theory underlying the invention</p> <p>"X" document of particular relevance; the claimed invention cannot be considered novel or cannot be considered to involve an inventive step when the document is taken alone</p> <p>"Y" document of particular relevance; the claimed invention cannot be considered to involve an inventive step when the document is combined with one or more other such documents, such combination being obvious to a person skilled in the art</p> <p>"&amp;" document member of the same patent family</p>													
<p>Date of the actual completion of the international search                  3 June 1994 (03.06.94)</p>		<p>Date of mailing of the international search report                  22 June 1994 (22.06.94)</p>												
<p>Name and mailing address of the ISA/AU                  AUSTRALIAN INDUSTRIAL PROPERTY ORGANISATION                  PO BOX 200                  WODEN ACT 2606                  AUSTRALIA                  Facsimile No. 06 2853929</p>		<p>Authorized officer                    D. LUM                  Telephone No. (06) 2832544</p>												

**INTERNATIONAL SEARCH REPORT**

International application No.

**PCT/AU 94/00082**

This Annex lists the known "A" publication level patent family members relating to the patent documents cited in the above-mentioned international search report. The Australian Patent Office is in no way liable for these particulars which are merely given for the purpose of information.

Patent Document Cited in Search Report		Patent Family Member					
AU	5224288	AU	17166/92	BR	9203751	EP	565250
		JP	6009306	MX	9202321		
EP	521570	NL	9101140				
AU	6201090	BR	9004365	FR	2652602	JP	3175924
		ZA	9007014				