

(No Model.)

2 Sheets—Sheet 1.

J. D. MORARITY.  
FOLDING BED.

No. 524,858.

Patented Aug. 21, 1894.

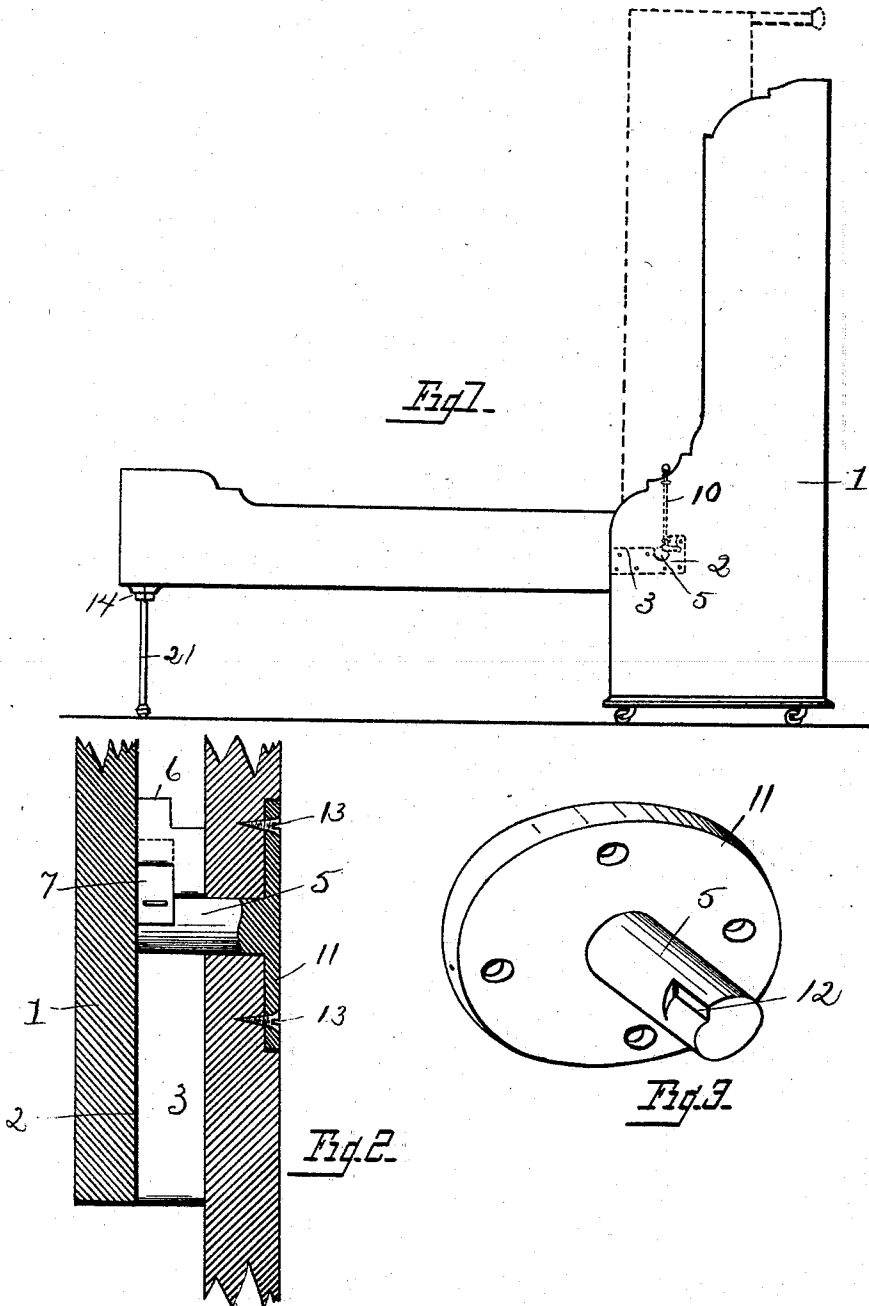

WITNESSES

Carroll J. Webster  
T. R. Webster

INVENTOR

John Daniel Morarity  
By William Webster  
Atty

(No Model.)

2 Sheets—Sheet 2.

J. D. MORARITY  
FOLDING BED.

No. 524,858.

Patented Aug. 21, 1894.

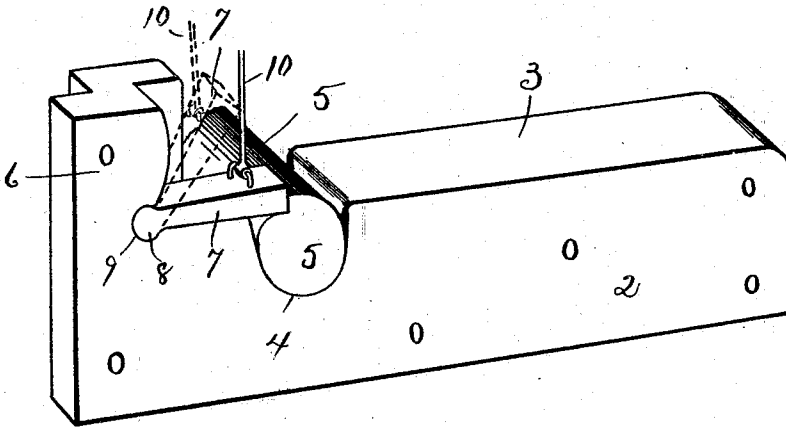

*Fig. 4.*

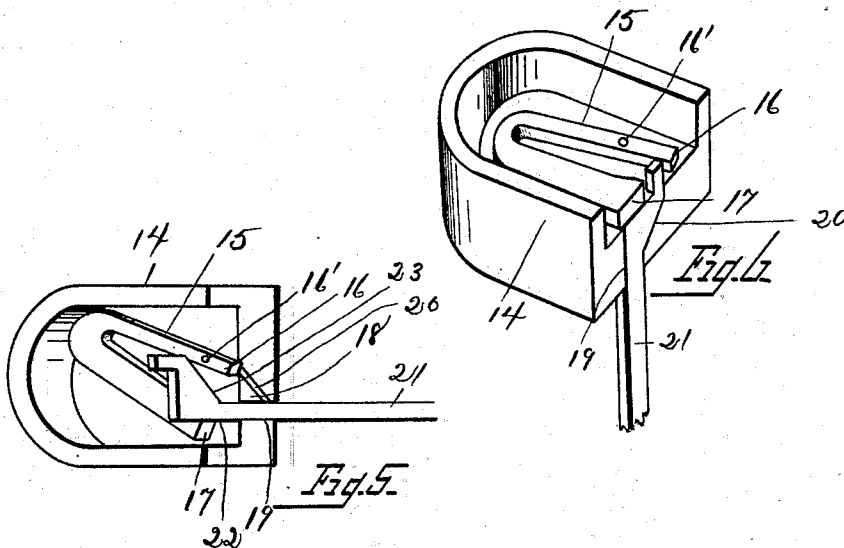

WITNESSES

Carroll J. Webster  
S R Webster.

INVENTOR

John Daniel Morarity  
By William Webster  
att'y

# UNITED STATES PATENT OFFICE.

JOHN DANIEL MORARITY, OF TOLEDO, OHIO.

## FOLDING BED.

SPECIFICATION forming part of Letters Patent No. 524,858, dated August 21, 1894.

Application filed July 28, 1893. Serial No. 481,699. (No model.)

*To all whom it may concern:*

Be it known that I, JOHN DANIEL MORARITY, of Toledo, county of Lucas, and State of Ohio, have invented certain new and useful  
5 Improvements in Folding Beds; and I do hereby declare that the following is a full, clear, and exact description of the invention, which will enable others skilled in the art to which it appertains to make and use the same,  
10 reference being had to the accompanying drawings, and to the figures of reference marked thereon, which form part of this specification.

My invention relates to a folding bed and  
15 has for its object to simplify the construction, and provide an automatic lock for the rails when extended.

A further object is to provide an automatic lock for the legs that shall secure the same  
20 in position to sustain the foot of the bed when extended, and be retracted when the bed is raised, to allow of housing the legs.

In the drawings: Figure 1 is a side elevation of the bed extended, the dotted lines  
25 showing the bed raised. Fig. 2 is a detail view showing the head side-rail in section, and the journal plate and pivot in position with the automatic lock in engagement with the pivot. Fig. 3 is a front elevation of the  
30 pivot plate and pivot. Fig. 4 is a side elevation of the journal plate showing the pivot journaled therein, and the lock in engagement therewith, and in dotted lines showing the lock raised. Fig. 5 is a perspective  
35 view of the lock for the leg showing the leg in locked position. Fig. 6 is a like view showing the locking dog rocked upon its pivot, and the leg released.

1 designates the head, upon the inner side of  
40 which is secured metal plates 2 each formed with a horizontal portion 3 into which are formed circular recesses 4 which serve as journal bearings for a pivot pin 5 secured in the bed rail, and an angled portion 6 recessed  
45 to receive a locking dog 7 pivotally secured in the same. Dog 7 is formed upon the inner end with a circular pivot 8, which seats in a circular recess 9 in the angled portion 6 and is free to raise from a horizontal to an  
50 inclined position in order to admit pivot 5 when the parts are assembled, or the removal of the bed support when desired, the dog be-

ing raised by means of a rod 10 connected therewith, and extended upon the inner side of the head within convenient reach. 55

Pivot 5 is formed integral with a plate 11 preferably circular in order to facilitate the proper adjustment of the pivot 5 to cause a  
60 shoulder 12 formed in the pivot to be in position to be engaged by the dog 7 to lock the bed when extended and the plate is secured in the bed rail by means of screws 13, after  
65 being properly adjusted. By this construction I am enabled to pivot the bed in the forward portion of the head, and thereby lessen the amount of supplemented weight usually  
70 required to properly balance the same to render it easy to raise to fold, and also have a perfect lock which automatically engages with the pivot and prevents accidental folding of the bed.

I have provided a novel and inexpensive lock for the leg comprising a plate 14 which is attached to the under side of the bed at the foot and is recessed upon the upper side  
75 to receive a U shaped locking dog 15 pivoted in one arm 16 at 16' to allow the end 17 of the opposite arm to swing across the end of the leg to lock the leg in extended position when the bed is extended, or to move by gravity  
80 to withdraw from contact with the leg when the bed is folded.

Plate 14 is formed in one end with a vertical recess 18 of a depth equal to the thickness of the leg, one side 19 of the recess being straight and co-incident with the outer  
85 edge of arm 17 when projected, the opposite side 20 of the recess being downwardly inclined and of a width at the top to co-incident with the inner edge of arm 16 when the dog  
90 is advanced.

The leg 21 comprises a straight portion 22 and an inclined upper portion 23 having an inclination co-incident with the side 20 of the recess whereby, when the leg is pulled  
95 out the inclined side will contact with the end of arm 16 of the lock upon its pivot, will project the end of arm 17 upon the end of the leg just as the inclined portion is fully seated in the recess. 100

It will be understood from the foregoing that the locking of the leg is accomplished automatically in the act of pulling the leg out, or in fact by gravitation of the leg as the

bed is extended. The release of the lock is also automatic, as, when the bed is folded the heavy end of the lock rocks upon the pivot and is withdrawn from contact with the leg, thereby allowing the leg to be pushed in.

It will be seen that I have reduced the expense of manufacture to a minimum, have provided for easy removal of the bed, it only being necessary to raise the pivot pins from the recesses, and slide it forward on the horizontal portion 3, and have provided for greater ease in opening or folding the bed, than before.

What I claim is—

1. In a folding bed, a head portion, plates secured upon each inner side having a horizontal portion formed with a journal bearing and a vertical portion having a pawl pivotally secured therein, the bed rails, pivots secured thereon journaled in the plates, and having a shoulder with which the pawl engages when the bed rails are extended.

2. In a folding bed, pivot pins formed with integral circular plates, a shoulder upon one pivot pin, bed rails having circular recesses to receive the plates, and openings through which the pivots are passed, the head having

plates upon the inner sides formed with journal bearings for the pivots, and a pawl for engagement with the shoulder upon the pivot pin and a connection with the pawl by which to raise the same from such engagement.

3. In a folding bed, a head, bed rails pivotally connected therewith, legs upon the rails each formed with an inclined side, and a horizontal top portion and a U shaped locking dog pivoted to swing across the top portion when the inclined side contacts therewith.

4. In a folding bed, a locking mechanism for the leg comprising a plate, a two armed locking dog pivoted thereon, and a leg formed with a straight side and inclined side, and a horizontal portion, whereby when the leg is pulled out, the inclined portion will contact with one arm, and force the opposite arm across the top of the leg.

In testimony that I claim the foregoing as my own I hereby affix my signature in presence of two witnesses.

JOHN DANIEL MORARITY.

Witnesses:

WILLIAM WEBSTER,  
F. R. WEBSTER.