

Nov. 28, 1967

J. H. HELTZEN ET AL

3,355,155

HUMIDIFIER FOR AIR CONDITIONING SYSTEMS

Filed Sept. 21, 1966

2 Sheets-Sheet 1

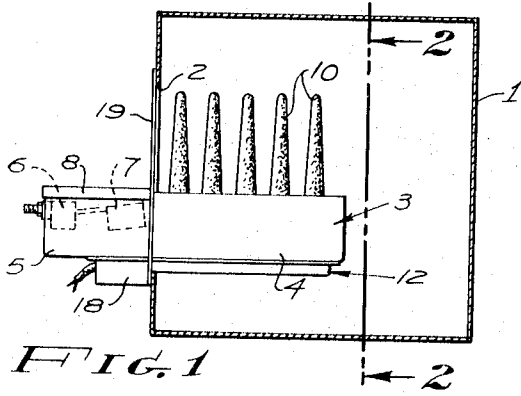

FIG. 1

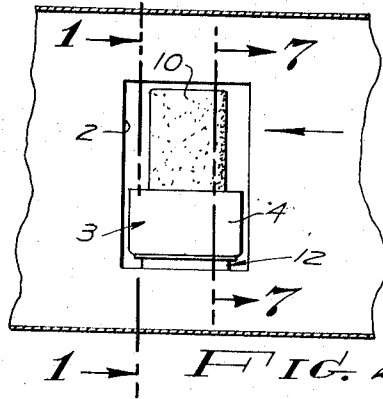

FIG. 2

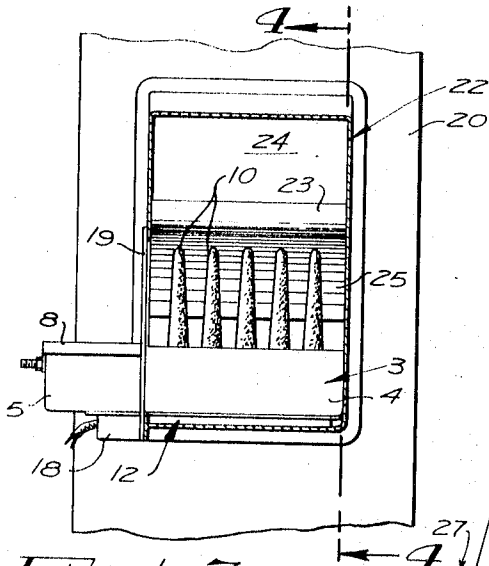

FIG. 3

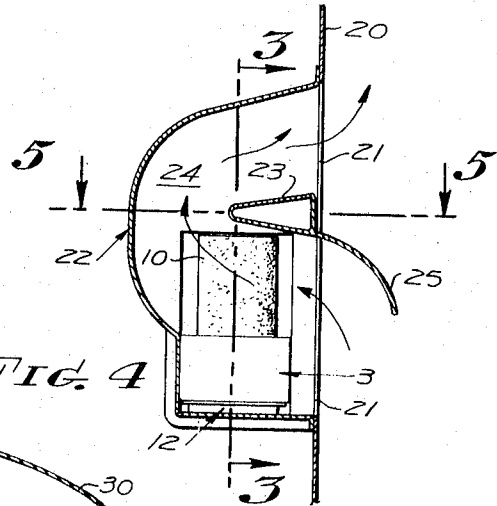

FIG. 4

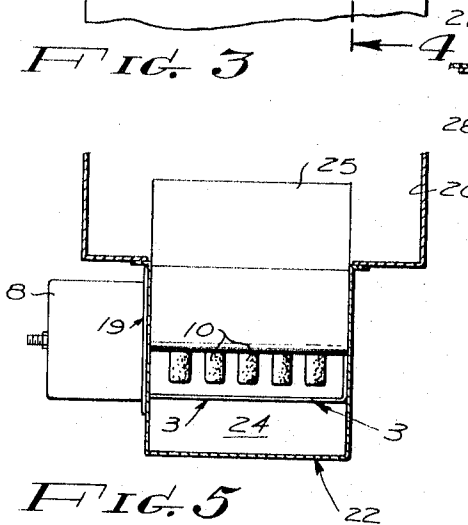

FIG. 5

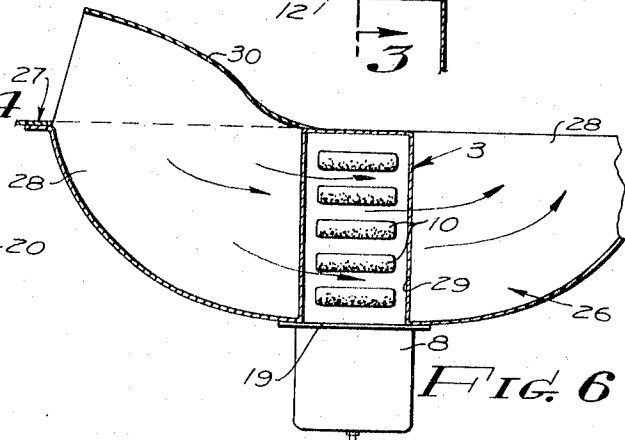

FIG. 6

JOHN H. HELTZEN
RICHARD W. MC CAHON
INVENTORS.

BY

Hyatt Hyatt
ATTORNEYS

Nov. 28, 1967

J. H. HELTZEN ET AL

3,355,155

HUMIDIFIER FOR AIR CONDITIONING SYSTEMS

Filed Sept. 21, 1966

2 Sheets-Sheet 2

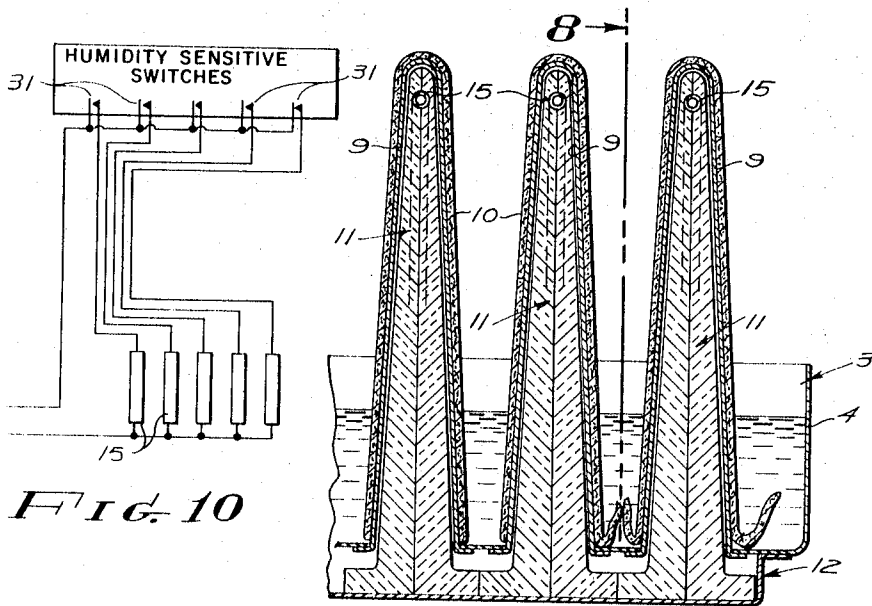

FIG. 10

FIG. 7

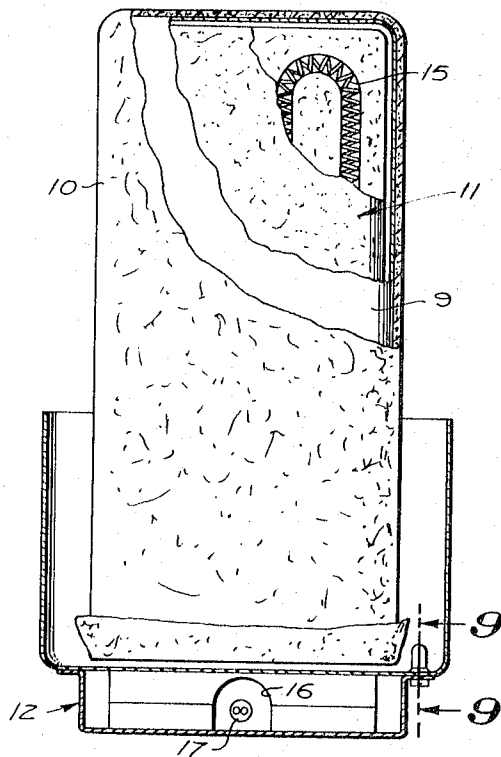

FIG. 8

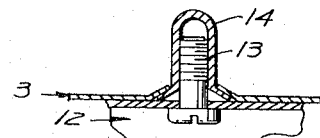

FIG. 9

JOHN H. HELTZEN
RICHARD W. MC CAHON
INVENTORS

BY *Lyons Lyons*
ATTORNEYS

1

2

3,355,155

HUMIDIFIER FOR AIR CONDITIONING SYSTEMS

John H. Heltzen, 22856 Leonora Drive, Woodland Hills, Calif. 91364, and Richard W. McCahon, 1018 S. Gladys, San Gabriel, Calif. 91776
 Filed Sept. 21, 1966, Ser. No. 580,988
 4 Claims. (Cl. 261—130)

ABSTRACT OF THE DISCLOSURE

A humidifier for air conditioning systems having a series of hollow upwardly directed shells sealed at their lower ends to a pan containing water; the exterior of said shells being covered with wick material and the interior receiving heating elements accessible from below the pan.

This invention relates to humidifiers for air conditioning systems and included in the objects of this invention are:

First, to provide a humidifier which may be readily installed in an existing duct, and which incorporates novelly arranged humidifier units, each covered by a readily replaceable wick.

Second, to provide a humidifier for air conditioning systems which includes a pan having an inner part adapted to be disposed in the path of air to be humidified, and an outer part containing a float controlled valve so that water may be maintained at a selected level, and a series of humidifier units extending upwardly from the inner part of the pan and covered with wicks exposed to the air stream.

Third, to provide a humidifier of the type mentioned in the second object, wherein each humidifier unit includes a hollow upwardly projecting shell sealed to the base of the pan, each shell receiving a heating element, the heating elements being supported in a substructure secured to the underside of the pan.

Fourth, to provide a humidifier for air conditioners one embodiment of which is adapted to be mounted on a horizontal duct.

Fifth, to provide a humidifier for air conditioners another embodiment of which is adapted to be mounted on a vertical duct and adaptable to flow of air in either direction.

With the above and other objects in view, as may appear hereinafter, reference is directed to the accompanying drawings in which:

FIGURE 1 is a transverse sectional view of a typical duct for an air conditioning system taken through 1—1 of FIGURE 2 and showing the humidifier in position.

FIGURE 2 is a fragmentary longitudinal sectional view of the air conditioner duct taken through 2—2 of FIGURE 1 and showing an end view of the humidifier.

FIGURE 3 is a sectional view taken through 3—3 of FIGURE 4, showing a bypass housing arranged for vertical flow with the humidifier indicated in side elevation therein, and showing in background and fragmentarily, a section of a duct for an air conditioning system.

FIGURE 4 is a fragmentary sectional view taken through 4—4 of FIGURE 3, showing the humidifier in end elevation.

FIGURE 5 is a fragmentary sectional view taken through 5—5 of FIGURE 4.

FIGURE 6 is a fragmentary sectional view showing a bypass housing arranged for horizontal flow and showing a humidifier in plan view.

FIGURE 7 is an enlarged fragmentary sectional view of the humidifier taken through 7—7 of FIGURE 2.

FIGURE 8 is an enlarged transverse sectional view of the humidifier taken through 8—8 of FIGURE 7.

FIGURE 9 is a fragmentary sectional view taken through 9—9 of FIGURE 8, showing one of the fastening means for joining the sub-pan to the main pan of the humidifier.

FIGURE 10 is a diagrammatical view illustrating the manner in which the units of the humidifier may be individually controlled so as to change the humidifying effect.

The humidifier is adapted to be mounted in a horizontal air duct 1, having a side opening 2 therein. The humidifier includes a pan 3 which is essentially rectangular in plan, and includes an inner part 4 adapted to be disposed within the duct 1 and an outer part 5 which protrudes from the duct.

The outer part 5 is provided with an inlet valve 6 which is controlled by a float 7 so that water may be maintained in the pan. The outer part 5 is provided with a cover 8.

The inner part 4 of the pan is provided with a series of wick supporting shells 9. Each shell defines a plane essentially parallel to the direction of flow of air in the duct. Each shell is hollow; its walls being formed of sheet material. The side walls preferably diverge downwardly and the lower end of each shelf is sealed to or formed integrally with the bottom of the pan 3. Fitted over each shell 9 is a wick 10, formed of woven or felted material or other porous material arranged to draw water from the pan so that each wick tends to remain wetted with water.

Each shell is open at its lower end and the interior of each shell forms a cavity for receiving a heating element support member 11. The support members are supported by their lower ends within a shallow sub-pan suitably secured to the underside of the pan 3, for example by screws 13 fitting in sockets 14 so that the sub-pan is completely isolated from the water contents of the pan 3. Each support member 11 is provided with a heating element 15 and their lower portions form a common conductor passage 16 for a conductor or conductors 17 connected to the heating elements 15.

The sub-pan 12 extends underneath the outer part 5 of the pan 3 and forms a terminal chamber 18.

At the boundaries separating the inner part 4 and outer part 5, the pan is surrounded by a transversely disposed mounting plate 19 which overlies the margins of the side opening 2. The humidifier is secured in place by screws or other fastening devices not shown.

Operation of the humidifier is as follows:

When the humidifier is installed, the planes defined by the shells 9 are essentially parallel to the direction of flow of air in the duct. Water is supplied through the inlet valve 6 and maintained between a predetermined minimum and maximum level by means of the float 7. The lower ends of the wicks are emersed in the water and draw the water upwardly by capillary action. The air stream is humidified by the evaporation of water from the wicks. The heating elements, which are controlled by a suitable thermostat not shown, maintain the shells 9 at a predetermined elevated temperature so as to increase the rate of evaporation of water into the air stream. By varying the temperature of the water in the wick, the moisture content of the air downstream from the humidifier may be controlled. It is not necessary that the series of shells and their wicks extend across the duct or in fact occupy a major portion of the duct. In fact the humidifier may be relatively small as compared to the cross section of the duct so as to present a minimal obstruction to the flow of air.

It is sometimes desirable, particularly for the purpose of installing the humidifier on a vertical duct, that the humidifier be mounted outside the duct and provide means

for bypassing a portion of the air through the humidifier. In this regard, reference is directed to FIGURES 3, 4 and 5. A vertical duct 20 is provided with a side opening 21. The opening is covered by a housing 22 provided with a baffle 23 in such a manner that an essentially U-shaped bypass duct 24 is provided. The lower portion of the bypass duct 24 is dimensioned to receive the inner part 4 of the pan 3, the pan being mounted essentially parallel to the side of the vertical duct 20. The baffle 23 is provided with a deflector lip 25 which extends into the duct 20 in an upstream direction. As illustrated in FIGURE 4, the direction of flow is upward; however, by inverting the baffle and deflector lip the installation is suitable for a vertical duct in which the air is flowing downward.

If a bypass duct is desirable in connection with a horizontal air duct, the arrangement shown in FIGURE 6 may be used. In this case the bypass duct 26 is fastened to the apertured side wall of a horizontal air duct 27. The bypass duct is provided with two essentially quadrant portions 28, separated by a channel 29, dimensioned to receive the inner portion 4 of the pan 3. An entrance scoop 30 projects into the horizontal air duct 27.

Reference is directed to FIGURE 10 in which the power supply to each humidifier heating element element 15 is connected to a corresponding switch 31 responsive to humidity. With this arrangement, the humidifier heating elements are activated or de-activated individually according to the demand for moisture in the air conditioning system. While in FIGURE 10 each element is connected to its individual switch, the heating elements may be arranged in groups, such as a pair being controlled by one switch, three by another, or all five by operation of both switches.

While the term "air conditioning system" has been used to designate the system in which the humidifier is used, it should be understood that such designation is intended to include heating and ventilating systems. Furthermore, the air duct and humidifier need not be permanent installation within the walls of a building, but may be within a fixed or movable cabinet, in which case the water may be supplied manually or from a reservoir.

While particular embodiments of this invention have been shown and described, it is not intended to limit the same to the details of the constructions set forth, but instead, the invention embraces such changes, modifications and equivalents of the various parts and their relationships as come within the purview of the appended claims.

We claim:

1. A humidifier for an air conditioning system, said humidifier comprising:

- (a) a pan adapted to be exposed to an air stream produced by an air conditioning system;
- (b) a plurality of hollow shells extending upwardly from the bottom of said pan, the interior of each

shell being isolated from the interior of said pan and open at its underside;

- (c) a sub-pan secured to the bottom of said pan and the interiors of said shells being exposed to said sub-pan;
 - (d) a series of heating element supports mounted in said sub-pan and extending into said shells;
 - (e) a series of heating elements carried by said supports for heating said shells;
 - (f) wicks covering said shells;
 - (g) and means for supplying water to said pan and for maintaining a selected level of water therein in which the lower ends of said wicks are emersed.
2. A humidifier according to claim 1, wherein:
- (a) said pan includes an inner and an outer part;
 - (b) a mounting plate surrounds said pan at the juncture of its inner and outer parts;
 - (c) and the margins of said pan being adapted to be fastened to the margins of a side opening formed in a duct constituting a part of said air conditioning system.
3. A humidifier according to claim 1, wherein:
- (a) said pan includes an inner and an outer part;
 - (b) a mounting plate surrounds said pan at the juncture of its inner and outer parts;
 - (c) a housing defining a bypass duct is fastened to a side of a duct forming a part of said air conditioning system, said housing having an inlet and an outlet, and a clearance opening for said pan therebetween;
 - (d) and the margins of said pan are fastened to the margins of said opening to place the inner part of said pan and said wicks in the path of air flowing through said bypass duct.
4. A humidifier according to claim 1, wherein:
- (a) at least a pair of humidity sensitive switches are located at stations remote from the heating elements;
 - (b) and said heating elements are divided into at least two corresponding groups electrically connected to said switches for selective operation of said groups of heating elements.

References Cited

UNITED STATES PATENTS

1,154,113	9/1915	Hadaway	219—274
2,214,269	9/1940	Bryant	126—113 XR
2,858,825	11/1958	Skerritt	
2,870,762	1/1959	Skerritt	261—104 XR
3,080,624	3/1963	Weber	219—274 XR
3,189,328	6/1965	Hotchkiss et al.	261—92 XR

HARRY B. THORNTON, *Primary Examiner.*

RONALD R. WEAVER, *Examiner.*